



The Future of Analog IC Technology®

EV23701-QEU-00A

High-Efficiency, Synchronous Step-Down LED Driver Evaluation Board

DESCRIPTION

The EV23701-QEU-00A Evaluation Board is designed to demonstrate the capabilities of MP23701. The MP23701 is a 24V monolithic synchronous step-down LED driver with a built-in power MOSFET and rectifier. It achieves up to 2A continue output current with excellent load and line regulation in a tiny UTQFN8(1.5mm*2.5mm) package. Peak current mode operation provides fast transient response and eases loop stabilization.

The EV23701-QEU-00A is typically designed for driving 1-2 WLEDs in series LED load with 1A LED current at wide 4.2V to 24V input range.

The EV23701-QEU-00A has high performances in efficiency, line/load regulation and deep analog dimming. Fault condition protection includes cycle-by-cycle peak current limiting, output short circuit protection, open LED protection, NTC thermal protection and thermal shutdown.

ELECTRICAL SPECIFICATION

| Parameter | Symbol | Value | Units |
|----------------|------------------|-----------|-------|
| Input Voltage | V _{IN} | 4.2 to 24 | V |
| Output Voltage | V _{OUT} | 3-6 | V |
| LED Current | I _{LED} | 1 | A |

FEATURES

- 4.2V to 24V Wide Input Range
- Synchronous Step-Down Converter
- 100mΩ Internal High-side Power MOSFET
- 80mΩ Internal Low-side Synchronous Rectifier
- Peak Current Mode Control
- 1A Continue Output Current
- 100mV Feedback Voltage
- Up to 95% Efficiency
- Fixed 1.5MHz Switching Frequency
- Analog Dimming
- Cycle-by-Cycle Current Limit
- Inherent LED Open Protection
- Output Short Circuit Protection
- NTC Thermal Protection
- Thermal Shutdown
- Auto-Restart Function

APPLICATIONS

- Infrared LED Driver
- General LED Driver
- Flashlight
- Handheld Computers Backlight

All MPS parts are lead-free, halogen free, and adhere to the RoHS directive. For MPS green status, please visit MPS website under Quality Assurance.

"MPS" and "The Future of Analog IC Technology" are Registered Trademarks of Monolithic Power Systems, Inc.

EV23701-QEU-00A EVALUATION BOARD



| | |
|-----------------------------|----------------------|
| (L x W) 50mm x 50mm | |
| Board Number | MPS IC Number |
| EV23701-QEU-00A | MP23701GQEU |

Efficiency vs. V_{IN}

V_{IN}=12V, T_A = 25°C

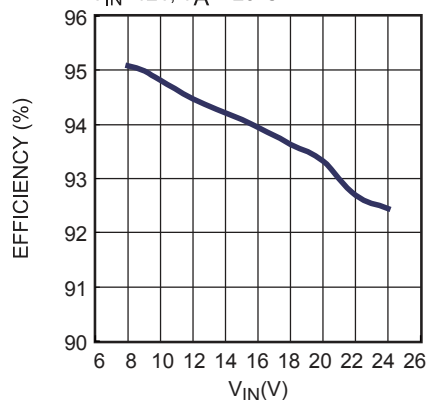

EVALUATION BOARD SCHEMATIC

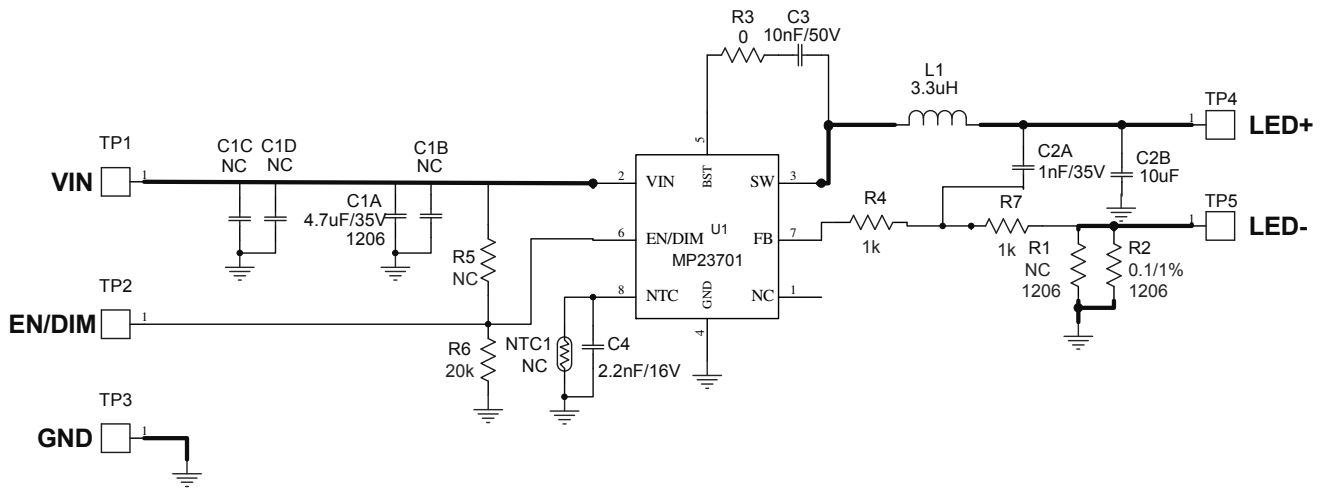

Figure 1 - Schematic

EV2410-JE-00A BILL OF MATERIALS

| Qty | Ref | Value | Description | Package | Manufacturer | Manufacturer_P/N |
|-----|-----------------|-----------------|-----------------------------|---------|--------------|---------------------|
| 1 | C1A | 4.7 μ F/35V | Ceramic Cap, 35V, X7R | 1206 | Taiyo Yuden | GMK316A7475KL-T |
| 4 | C1B,C1C C1D, | NC | | | | |
| 1 | C2A | 1nF/50V | Ceramic Cap, 50V, X7R | 0603 | muRata | GRM033R71H102KA12D |
| 1 | C2B | 10 μ F/35V | Ceramic Cap, 35V, X7R | 1210 | muRata | GRM32ER7YA106KA12L |
| 1 | C3 | 10nF/50V | Ceramic Cap, 50V, X7R | 0603 | muRata | GRM188R71H103KA01D |
| 1 | C4 | 2.2nF/16V | Ceramic Cap, 16V, X7R | 0603 | muRata | GRM188R71C222KA01D |
| 1 | L1 | 3.3 μ H | Inductor, 3.3 μ H, 4.4A | SMD | TDK | RLF7030-3R3M4R1(非标) |
| 1 | NTC1 | NC | | | | |
| 1 | R1 | 100m Ω | Thick Film Chip RES, 1% | 1206 | CYNTEC | RL1632H-R100-FN |
| 1 | R2 | NC | | | | |
| 1 | R3 | 0 Ω | Thick Film Chip RES, 1% | 0603 | Yageo | RC0603FR-070RL |
| 2 | R4,R7 | 1k Ω | Thick Film Chip RES, 1% | 0603 | Yageo | RC0603FR-071KL |
| 1 | R5 | NC | | | | |
| 1 | R6 | 20k Ω | Thick Film Chip RES, 1% | 0603 | Yageo | RC0603FR-0720KL |
| 1 | U1 | MP23701 | Sync Step-down LED Driver | UTQFN8 | MPS | MP23701GQEU-Z |

EVB TEST RESULTS

Performance waveforms are tested on the evaluation board.

$V_{IN} = 12V$, 2 WLEDs in series, $V_{OUT} = 6V$, $I_{LED} = 1A$, $L = 3.3\mu H$, $T_A = 25^\circ C$, unless otherwise noted.

Steady State

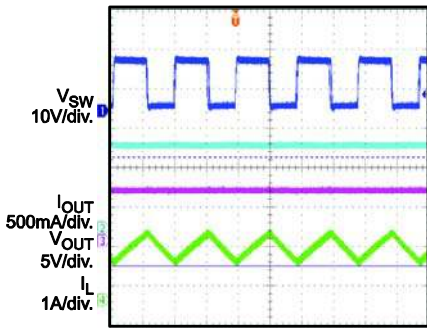

400ns/div.

V_{IN} Start-Up

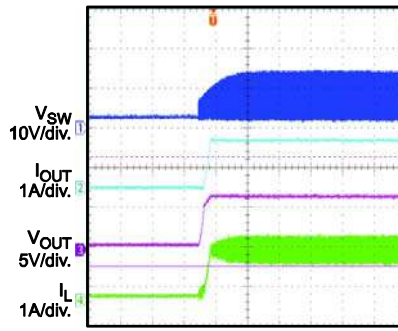

4ms/div.

EN Start-Up

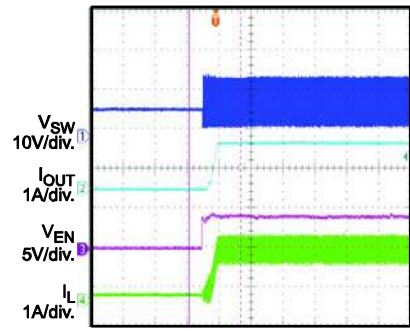

2ms/div.

EN Shutdown

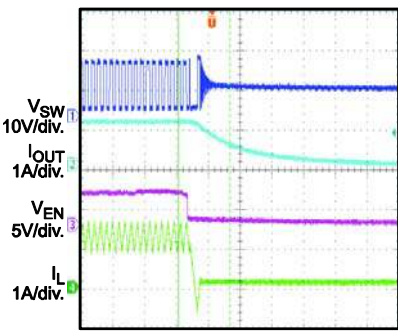

4μs/div

Analog Dimming

$V_{IN}=5V$, 1WLED, $V_{OUT}=3V$,
 $I_{LED}=1A$, $V_{DIM}=1V$

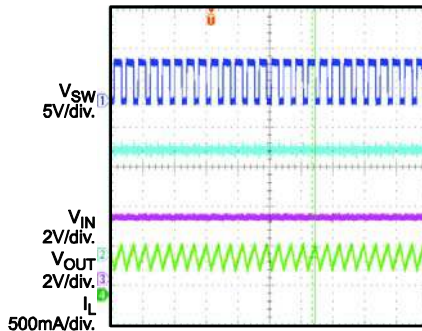

2μs/div

PWM Dimming

$V_{IN}=5V$, 1WLED, $V_{OUT}=3V$,
 $I_{LED}=1A$, 200Hz/D=50%

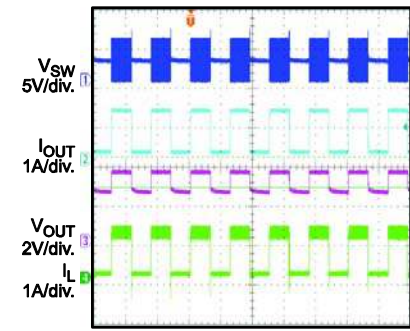

4ms/div

Open LED Protection

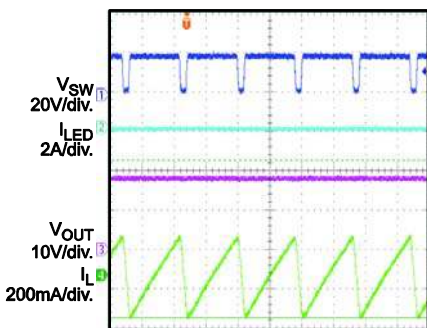

400ns/div

Short LED+ to LED- Protection

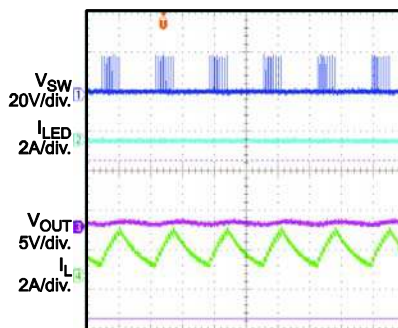

10μs/div

Short LED+ to GND Protection

$V_{IN}=5V$, 1WLED, $V_{OUT}=3V$, $I_{LED}=1A$

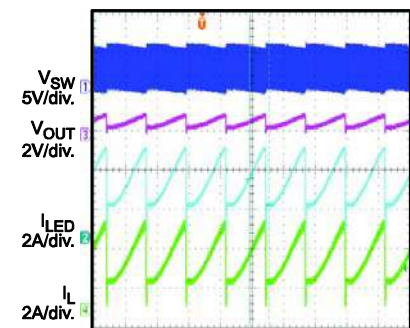

2ms/div

PRINTED CIRCUIT BOARD LAYOUT (DOUBLE-SIDED)

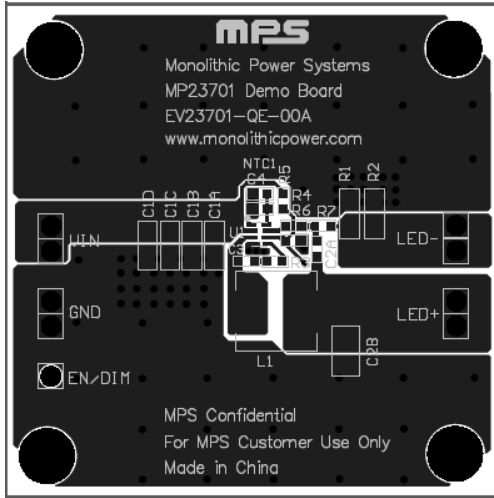

Figure 2 - Top Layer

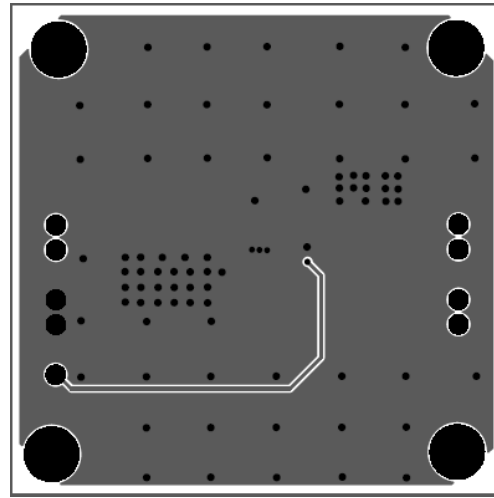

Figure 3 - Bottom Layer

QUICK START GUIDE

1. Preset DC Power Supply output to 4.2V to 24V and turn off Power Supply.
2. Connect the positive terminal of Power Supply output to the VIN pin and the negative terminal to the GND pin.
3. Connect the LED load between “LED+” (anode of LED string) and “LED-”(cathode of LED string).
4. Turn on Power Supply.
5. Apply the Enable voltage to the EN/DIM pin and drive Enable high to turn on the chip. When Enable voltage is less than 0.3V, the chip is turned off.
6. To apply analog dimming, a variable DC signal (0.6V to 1.5V) is required. Connect the positive and negative terminals of DC signal to the EN/DIM and GND pins, respectively. By adjusting the voltage level from 0.6V to 1.5V, the LED current changes from the min scale to full scale of the maximum LED current. If the dimming voltage is higher than 1.5V, the maximum LED current is generated.
7. Tie a NTC resistor to NTC pin to adjust V_{NTC} to implement thermal protection.
8. C1B, C1C, C1D are as option to improve EMI performance, the 10nF or 22nF low ESR ceramic cap is recommended to filter the noise.

NOTICE: The information in this document is subject to change without notice. Please contact MPS for current specifications. Users should warrant and guarantee that third party Intellectual Property rights are not infringed upon when integrating MPS products into any application. MPS will not assume any legal responsibility for any said applications.