

**STRAIGHT PLUG CRIMP TYPE**  
**FOR CABLE 2.6/50**

**R141A.075.161**

Series : ECO BNC 50

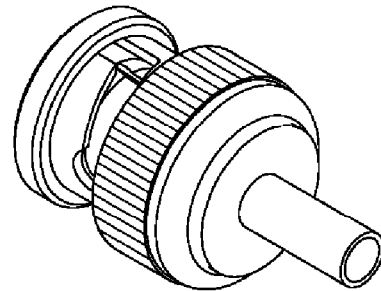
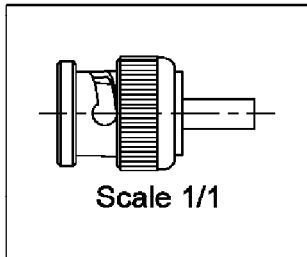
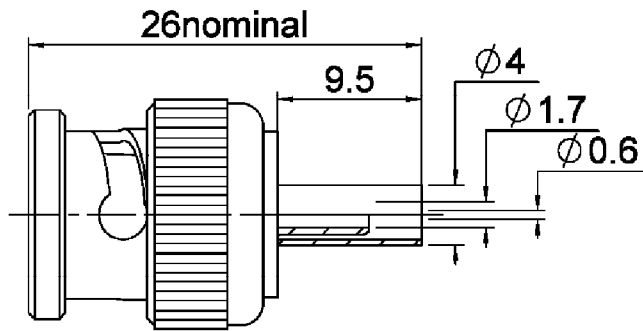

All dimensions are in mm.

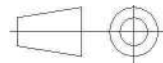

COMPONENTS	MATERIALS	PLATING ( $\mu\text{m}$ )
BODY	BRASS	NICKEL
CENTER CONTACT	BRASS	GOLD
OUTER CONTACT		
INSULATOR	PTFE	
GASKET		
OTHERS PARTS	BRASS	NICKEL
-	-	-
-	-	-

Issue : 1003 B

In the effort to improve our products, we reserve the right to make changes judged to be necessary.



**STRAIGHT PLUG CRIMP TYPE**

**FOR CABLE 2.6/50**

**R141A.075.161**

Series : **ECO BNC 50**

**PACKAGING**

Standard	Unit	Other
<b>100</b>	<b>'W' option</b>	<b>Contact us</b>

**SPECIFICATION**

**ELECTRICAL CHARACTERISTICS**

Impedance		<b>50</b> Ω
Frequency		<b>0-1</b> GHz
VSWR	<b>1.3 +</b>	<b>0,0000</b> x F(GHz) Maxi
Insertion loss		<b>0.2</b> √F(GHz) dB Maxi
RF leakage	- (	<b>NA</b> - F(GHz)) dB Maxi
Voltage rating		<b>500</b> Veff Maxi
Dielectric withstanding voltage		<b>1000</b> Veff mini
Insulation resistance		<b>5000</b> MΩ mini

**CABLE ASSEMBLY**

Stripping	a	b	c	d	e	f
mm	3,00	6,50	11,3	0,00	8,30	0,00

Assembly instruction : **Crimp 01**

Recommended cable(s)desnor  
KX 22A  
RG 316  
RG 188

repere

Characteristics indicated on this data sheet are those that can be achieved with the highest performance cable. Intrinsic limitations of the cable may diminish the performance of the assembly

Cable retention

- pull off **40** N mini  
- torque **NA** N.cm

**MECHANICAL CHARACTERISTICS**

Center contact retention		
Axial force – Mating end	<b>27</b>	N mini
Axial force – Opposite end	<b>27</b>	N mini
Torque	<b>NA</b>	N.cm mini

**TOOLING**

Part Number	Description	Hexagon
.	.	.
R282.293.000	CRIMPING TOOL M22520/5-01	
R282.235.900		3.51

Recommended torque		
Mating	<b>NA</b>	N.cm
Panel nut	<b>NA</b>	N.cm
Clamp nut	<b>NA</b>	N.cm
A/F clamp nut	<b>0,0000</b>	mm

Mating life	<b>100</b>	Cycles mini
Weight	<b>10,0000</b>	g

**OTHER CHARACTERISTICS**

**ENVIRONMENTAL**

Operating temperature	<b>-40/+85</b>	° C
Hermetic seal	<b>NA</b>	Atm.cm3/s
Panel leakage	<b>NA</b>	

Issue : **1003 B**

In the effort to improve our products, we reserve the right to make changes judged to be necessary.



**STRAIGHT PLUG CRIMP TYPE**  
**FOR CABLE 2.6/50**

**R141A.075.161**

Series : ECO BNC 50

**Crimp 01 : Soldered contact**

**COMPONENTS**

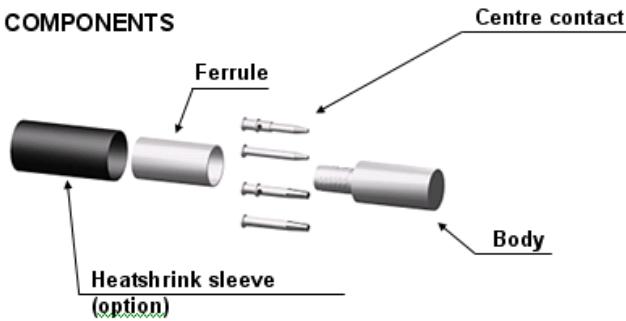

**STRIPPING DIMENSIONS**

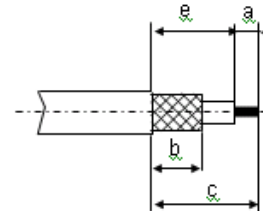

**1**

Slide the heatshrink sleeve onto the cable (Option).  
 Slide the ferrule onto the cable.  
 Strip the cable.

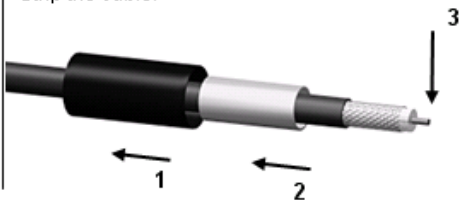

**4**

Slide the cable into the body until it bottoms against the insulator.

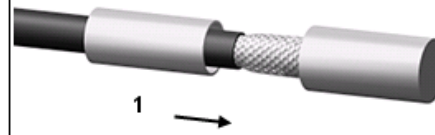

**2**

Slide the centre contact on until it bottoms against the cable dielectric.  
 Solder the centre contact.  
 Clean solder area.



**5**

Slide the ferrule over the braid.  
 Crimp the ferrule with crimping tool (see connector TDS).

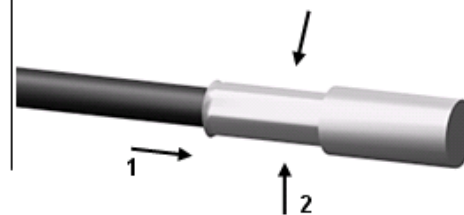

**3**

Fan the braid.

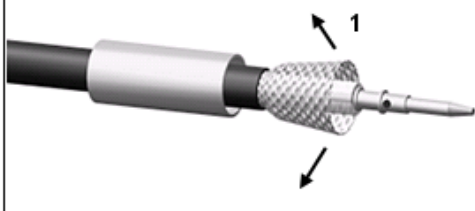

**6**

Cut the excess of braid if necessary.  
 Slide the sleeve over the ferrule and heatshrink it in place (Option).

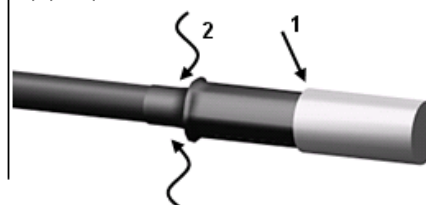

**Issue : 1003 B**

In the effort to improve our products, we reserve the right to make changes judged to be necessary.

