

2 CIRCUIT PART

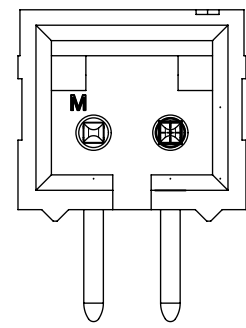

- NOTES:
- HOUSING MATERIAL: LCP, UL94V-0, BLACK  
TERMINAL MATERIAL: BRASS
  - FINISH:  
MATTE TIN - 2.54 MICROMETERS MINIMUM MATTE TIN OVER NICKEL.  
0.38 GOLD - SELECT GOLD IN MATING AREA: 0.38 MICROMETERS MINIMUM  
SELECT MATTE TI IN PC TAIL: 2.0 MICROMETERS MINIMUM  
WITH OVERALL NICKEL UNDERPLATE  
0.75 GOLD - SELECT GOLD IN MATING AREA: 0.75 MICROMETERS MINIMUM  
SELECT MATTE TI IN PC TAIL: 2.0 MICROMETERS MINIMUM  
WITH OVERALL NICKEL UNDERPLATE
  - PRODUCT SPECIFICATION: 1719710000-PS AND PS-70400
  - PACKAGING SPECIFICATION: TUBES PER 1719740000-PK
  - HEADER MATES WITH: OPTION "G" 70400 AND 70430 SERIES SL CONNECTORS
  - COSMETIC SPECIFICATION: PS-45499-002 CLASS B
  - SOLDERABILITY PER SMES-152 LEAD FREE ALLOY

CKTS	A	B
2	7.54	2.54
3	10.08	5.08
4	12.62	7.62
5	15.16	10.16
6	17.70	12.70
7	20.24	15.24
8	22.78	17.78
9	25.32	20.32
10	27.86	22.86
11	30.40	25.40
12	32.94	27.94
13	35.48	30.48
14	38.02	33.02
15	40.56	35.56
16	43.10	38.10
17	45.64	40.64
18	48.18	43.18
19	50.72	45.72
20	53.26	48.26
21	55.80	50.80
22	58.34	53.34
23	60.88	55.88
24	63.42	58.42
25	65.96	60.96

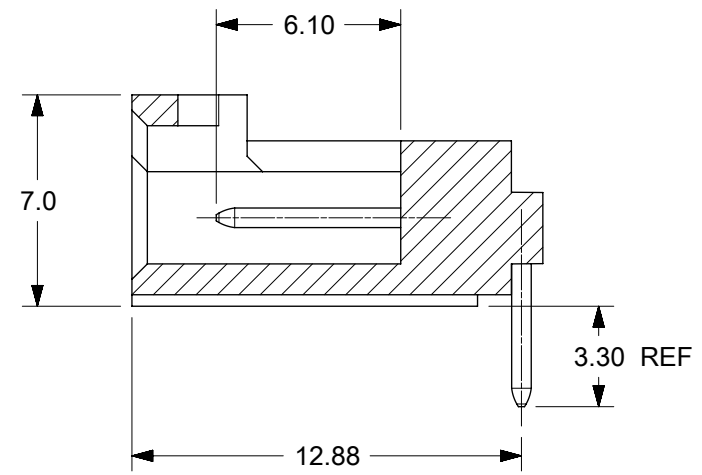
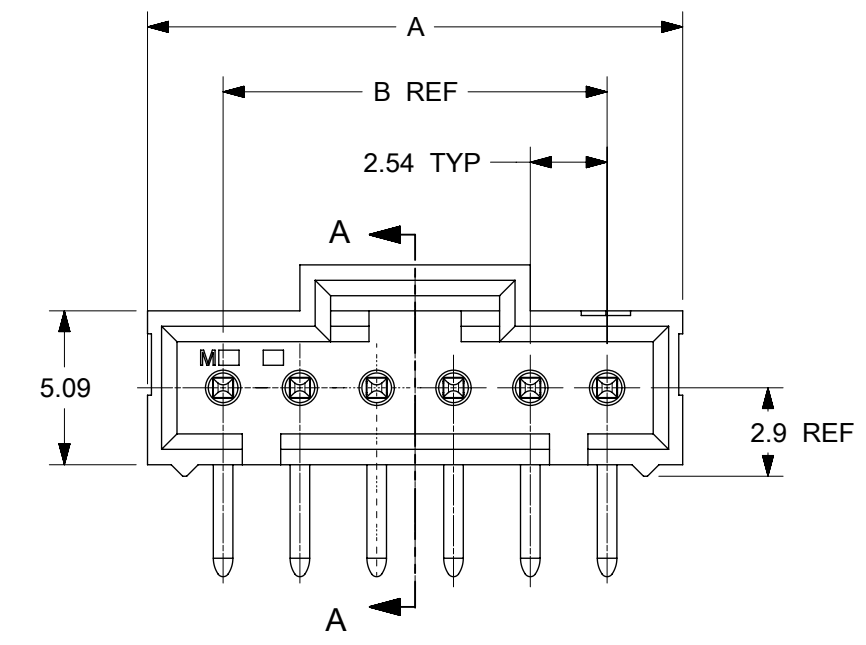

SECTION A-A

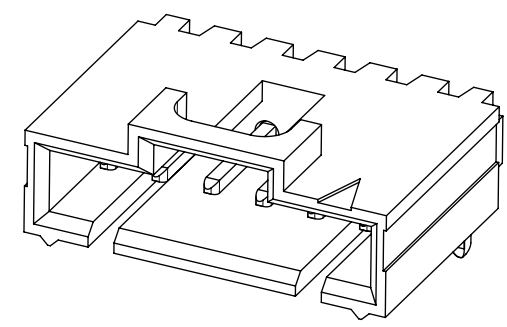

6 CIRCUIT PART SHOWN  
SEE CHART FOR OTHER OPTIONS

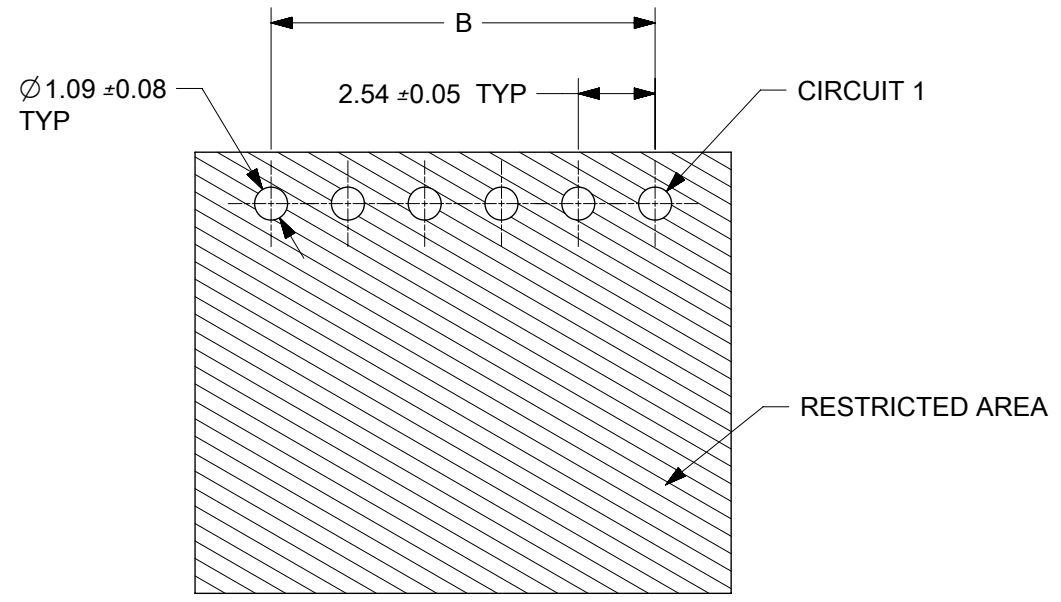

PCB LAYOUT: COMPONENT SIDE  
RECOMMENDED PCB THICKNESS: 1.57

<b>SYMBOLS</b> ▽ = 0 ▽ = 0 ▽ = 0 ▽ = 0 ▽ = 0 ▽ = 0 ▽ = 0 ▽ = 0 ▽ = 0 ▽ = 0 ▽ = 0 ▽ = 0	THIS DRAWING CONTAINS INFORMATION THAT IS PROPRIETARY TO MOLEX ELECTRONIC TECHNOLOGIES, LLC AND SHOULD NOT BE USED WITHOUT WRITTEN PERMISSION		DIMENSION UNITS: <b>mm</b> SCALE: <b>4:1</b>		CURRENT REV DESC: RELEASED TO MARKET					
	GENERAL TOLERANCES (UNLESS SPECIFIED)		EC NO: 174680 DRWN: KSAMIEC 2018/04/04 CHK'D: MKIPPER 2018/04/09 APPR: FSMITH 2018/04/11		PRODUCT CUSTOMER DRAWING					
	ANGULAR TOL ± 0.5°		INITIAL REVISION:		DOCUMENT NUMBER: 1719740000-SD			DOC TYPE: PSD	DOC PART: 000	REVISION: A6
	4 PLACES ± 3 PLACES ± 2 PLACES ± 0.25 1 PLACE ± 0.38 0 PLACES ± 0.0		DRWN: KSAMIEC 2016/08/30 APPR: FSMITH 2016/10/03		MATERIAL NUMBER: SEE CHART			CUSTOMER: GENERAL MARKET		SHEET NUMBER: 1 OF 2

	10	9	8	7	6	5	4	3	2	1
F		TIN	0.38 GOLD	0.75 GOLD						
	CIRCUIT SIZE	MATERIAL NUMBER	MATERIAL NUMBER	MATERIAL NUMBER						
	2	171974-0002	171974-0102	171974-0202						
E	3	171974-0003	171974-0103	171974-0203						
	4	171974-0004	171974-0104	171974-0204						
	5	171974-0005	171974-0105	171974-0205						
	6	171974-0006	171974-0106	171974-0206						
	7	171974-0007	171974-0107	171974-0207						
	8	171974-0008	171974-0108	171974-0208						
	9	171974-0009	171974-0109	171974-0209						
	10	171974-0010	171974-0110	171974-0210						
	11	171974-0011	171974-0111	171974-0211						
	12	171974-0012	171974-0112	171974-0212						
D	13	171974-0013	171974-0113	171974-0213						
	14	171974-0014	171974-0114	171974-0214						
	15	171974-0015	171974-0115	171974-0215						
	16	171974-0016	171974-0116	171974-0216						
	17	171974-0017	171974-0117	171974-0217						
	18	171974-0018	171974-0118	171974-0218						
	19	171974-0019	171974-0119	171974-0219						
	20	171974-0020	171974-0120	171974-0220						
C	21	171974-0021	171974-0121	171974-0221						
	22	171974-0022	171974-0122	171974-0222						
	23	171974-0023	171974-0123	171974-0223						
	24	171974-0024	171974-0124	171974-0224						
	25	171974-0025	171974-0125	171974-0225						

SYMBOLS	THIS DRAWING CONTAINS INFORMATION THAT IS PROPRIETARY TO MOLEX ELECTRONIC TECHNOLOGIES, LLC AND SHOULD NOT BE USED WITHOUT WRITTEN PERMISSION															
	DIMENSION UNITS		SCALE		CURRENT REV DESC: RELEASED TO MARKET						<b>molex</b>					
	mm		1:1		EC NO: 174680 DRWN: KSAMIEC 2018/04/04 CHK'D: MKIPPER 2018/04/09 APPR: FSMITH 2018/04/11											
	GENERAL TOLERANCES (UNLESS SPECIFIED)		ANGULAR TOL ± 0.5°								PRODUCT CUSTOMER DRAWING					
	▽ = 0		4 PLACES ±								INITIAL REVISION:					
	▽ = 0		3 PLACES ±		DRWN: KSAMIEC 2016/08/30		DOCUMENT NUMBER		DOC TYPE		DOC PART					
	▽ = 0		2 PLACES ± 0.25		APPR: FSMITH 2016/10/03		1719740000-SD		PSD		000					
	▽ = 0		1 PLACE ± 0.38		DRAFT WHERE APPLICABLE MUST REMAIN WITHIN DIMENSIONS		THIRD ANGLE PROJECTION		DRAWING		SERIES					
	▽ = 0		0 PLACES ± 0.0		B-SIZE		171974		MATERIAL NUMBER		CUSTOMER					
	▽ = 0				SEE CHART		GENERAL MARKET		SHEET NUMBER		2 OF 2					