

## FEATURES

Third-order, low-pass video filter

1 dB flatness out to 6 MHz

27 dB rejection at 27 MHz

Low quiescent current: 4.7 mA typical

Low power-down current: 24  $\mu$ A typical

Load detection capability

SAG correction

Allows use of smaller capacitors in ac-coupled outputs

Low supply voltage: 2.5 V to 3.6 V

Charge pump

Creates a negative voltage from single positive supply

Allows capless output coupling with no dc offset

Rail-to-rail output

High input-to-output isolation in disabled state

89 dB @ 1 MHz

Small package

3 mm  $\times$  3 mm LFCSP

Low 0.55 mm package height

Wide operating temperature range:  $-40^{\circ}\text{C}$  to  $+85^{\circ}\text{C}$

## APPLICATIONS

Portable media players

Portable gaming consoles

Cell phones

Digital still cameras

Portable DVD players

Portable video cameras

## GENERAL DESCRIPTION

The [ADA4431-1](#) is a fully integrated video reconstruction filter that combines excellent video specifications with low power consumption, making it ideal for portable video filtering applications. The [ADA4431-1](#) is able to detect whether a video load is present at the output, powering down the device when the load is disconnected.

The [ADA4431-1](#) operates on single supplies as low as 2.5 V while providing the dynamic range required by the most demanding video systems. The on-board charge pump provides a virtual negative supply, allowing the video signal to be dc-coupled and the black level to be set to ground, while the sync passes cleanly at 300 mV below ground.

## PIN CONFIGURATION

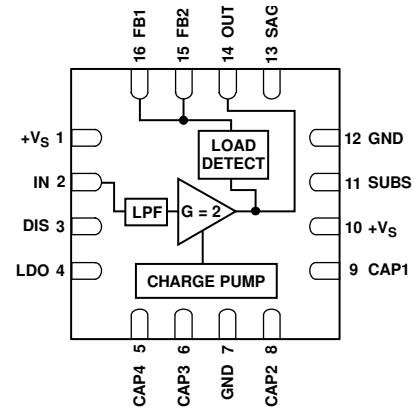

Figure 1.

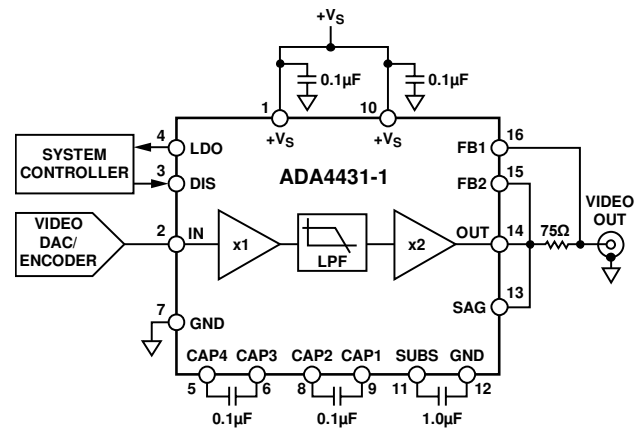

Figure 2. Typical Application Circuit

When operating with the charge pump off, the [ADA4431-1](#) provides a dc offset to keep the sync tip approximately 100 mV above ground. In addition, the part features SAG correction, which permits the use of smaller capacitors in applications with ac-coupled outputs.

The [ADA4431-1](#) is packaged in a low profile 16-lead LFCSP and operates in the industrial temperature range of  $-40^{\circ}\text{C}$  to  $+85^{\circ}\text{C}$ .

**TABLE OF CONTENTS**

Features .....	1	Pin Configuration and Function Descriptions.....	6
Applications.....	1	Typical Performance Characteristics .....	7
Pin Configuration.....	1	Theory of Operation .....	9
General Description .....	1	Overview .....	9
Revision History .....	2	Charge Pump Operation .....	9
Specifications.....	3	Load Detect .....	9
Absolute Maximum Ratings.....	5	Evaluation Board .....	10
Thermal Resistance .....	5	Outline Dimensions .....	12
Maximum Power Dissipation .....	5	Ordering Guide .....	12
ESD Caution.....	5		

**REVISION HISTORY**

**11/15—Rev. 0 to Rev. A**

Changes to -3 dB Bandwidth Parameter, Table 1.....	3
Changes to -3 dB Bandwidth Parameter, Table 2.....	4
Changes to Figure 4 and Table 5.....	6
Updated Outline Dimensions .....	12
Changes to Ordering Guide .....	12

**8/07—Revision 0: Initial Version**

## SPECIFICATIONS

$V_S = 3.0\text{ V}$  (@  $T_A = 25^\circ\text{C}$ ,  $V_{IN} = 1\text{ V p-p}$ ,  $R_L = 150\ \Omega$ ,  $DIS = 3.0\text{ V}$ , charge pump on), unless otherwise noted.

Table 1.

Parameter	Test Conditions/Comments	Min	Typ	Max	Unit
<b>ELECTRICAL SPECIFICATIONS</b>					
Quiescent Supply Current					
Normal Mode	Video load present		4.7	7.2	mA
Load Searching Mode	No video load		0.1		mA
Disabled Mode	$DIS = 0\text{ V}$		24		$\mu\text{A}$
Disable Pin Current	$DIS = 3.0\text{ V}$ (enabled and charge pump on)		3	6	$\mu\text{A}$
	$DIS = 0\text{ V}$ (disabled)		-17	-30	$\mu\text{A}$
Supply Voltage Range		2.5		3.6	V
Input Voltage	Limited by output range		1.3		V
Input Resistance			10		$\text{M}\Omega$
Input Capacitance			1		pF
Output Voltage Range			-0.8 to +2.8		V
Output Offset Voltage		-650	-600	-560	mV
Power Supply Rejection	$f = 100\text{ kHz}$ , output referred	36	42		dB
Pass-Band Gain		5.7	6.0	6.2	dB
Input-to-Output Isolation—Disabled	$f = 1\text{ MHz}$ , $DIS = 0\text{ V}$		89		dB
<b>FILTER CHARACTERISTICS</b>					
-3 dB Bandwidth		6.6	7.9	9.1	MHz
1 dB Flatness			6		MHz
Out-of-Band Rejection	$f = 27\text{ MHz}$	25	27		dB
Differential Gain	Modulated 10 step ramp, sync tip at 0 V		0.7		%
Differential Phase	Modulated 10 step ramp, sync tip at 0 V		0.3		Degrees
Linear Output Current			40		mA
Group Delay Variation	$f = 100\text{ kHz}$ to 5 MHz		30		ns

$V_S = 3.0\text{ V}$  (@  $T_A = 25^\circ\text{C}$ ,  $V_{IN} = 1\text{ V p-p}$ ,  $R_L = 150\ \Omega$ , DIS = floating, charge pump off), unless otherwise noted.

Table 2.

Parameter	Test Conditions/Comments	Min	Typ	Max	Unit
<b>ELECTRICAL SPECIFICATIONS</b>					
Quiescent Supply Current					
Normal Mode	Video load present		1.6	2.2	mA
Load Searching Mode	No video load		0.1		mA
Disabled Mode	DIS = 0 V		24		$\mu\text{A}$
Disable Pin Current	DIS = 0 V		-17	-30	$\mu\text{A}$
Supply Voltage Range		2.5		3.6	V
Input Voltage	Limited by output range		1.3		V
Input Resistance			10		$\text{M}\Omega$
Input Capacitance			1		pF
Output Voltage Range			0 to 2.8		V
Output Offset Voltage			0.1	0.2	V
Power Supply Rejection	f = 100 kHz, output referred	38	48		dB
Pass-Band Gain		5.8	6.0	6.2	dB
Input-to-Output Isolation—Disabled	f = 1 MHz, DIS = 0 V		89		dB
<b>FILTER CHARACTERISTICS</b>					
-3 dB Bandwidth		6.2	7.5	8.4	MHz
1 dB Flatness			6		MHz
Out-of-Band Rejection	f = 27 MHz	26	29		dB
Differential Gain	Modulated 10 step ramp, sync tip at 0 V		0.4		%
Differential Phase	Modulated 10 step ramp, sync tip at 0 V		0.3		Degrees
Linear Output Current			40		mA
Group Delay Variation	f = 100 kHz to 5 MHz		30		ns

## ABSOLUTE MAXIMUM RATINGS

Table 3.

Parameter	Rating
Supply Voltage	4.0V
Power Dissipation	See Figure 3
Storage Temperature Range	-65°C to +125°C
Operating Temperature Range	-40°C to +85°C
Lead Temperature (Soldering 10 sec)	300°C
Junction Temperature	150°C

Stresses at or above those listed under Absolute Maximum Ratings may cause permanent damage to the product. This is a stress rating only; functional operation of the product at these or any other conditions above those indicated in the operational section of this specification is not implied. Operation beyond the maximum operating conditions for extended periods may affect product reliability.

### THERMAL RESISTANCE

$\theta_{JA}$  is specified for the device (including exposed pad) soldered to a high thermal conductivity 2s2p circuit board, as described in EIA/JESD 51-7. The exposed pad is not electrically connected to the device. It is typically soldered to a pad on the PCB that is thermally and electrically connected to an internal ground plane.

Table 4. Thermal Resistance

Package Type	$\theta_{JA}$	Unit
16-lead LFCSP-UQ (CP-16-12)	43	°C/W

### MAXIMUM POWER DISSIPATION

The maximum safe power dissipation in the [ADA4431-1](#) package is limited by the associated rise in junction temperature ( $T_J$ ) on the die. At approximately 150°C, which is the glass transition temperature, the plastic changes its properties. Even temporarily exceeding this temperature limit can change the stresses that the package exerts on the die, permanently shifting the parametric performance of the [ADA4431-1](#). Exceeding a junction temperature of 150°C for an extended period can result in changes in the silicon devices potentially causing failure.

The power dissipated in the package ( $P_D$ ) is the sum of the quiescent power dissipation and the power dissipated in the package due to the load drive. The quiescent power is the voltage between the supply pins ( $V_S$ ) times the quiescent current ( $I_S$ ). The power dissipated due to the load drive depends upon the particular application. The power due to load drive is calculated by multiplying the load current by the associated voltage drop across the device. RMS voltages and currents must be used in these calculations.

Airflow increases heat dissipation, effectively reducing  $\theta_{JA}$ . In addition, more metal directly in contact with the package leads and exposed pad from metal traces, through-holes, ground, and power planes reduces the  $\theta_{JA}$ .

Figure 3 shows the maximum safe power dissipation in the package vs. the ambient temperature for the 16-lead LFCSP package (43°C/W) on a JEDEC standard 4-layer board.

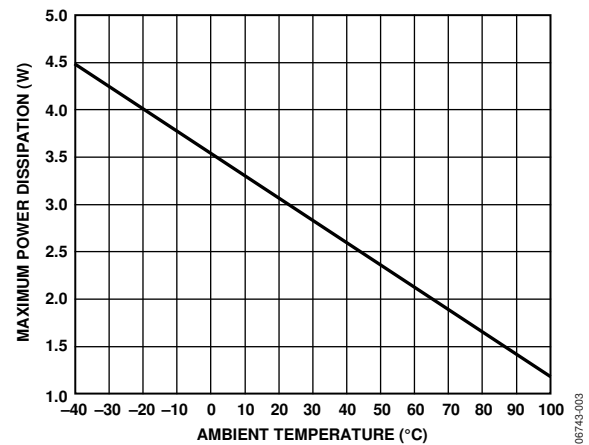

Figure 3. Maximum Power Dissipation vs. Temperature for a 4-Layer Board

### ESD CAUTION



**ESD (electrostatic discharge) sensitive device.** Charged devices and circuit boards can discharge without detection. Although this product features patented or proprietary protection circuitry, damage may occur on devices subjected to high energy ESD. Therefore, proper ESD precautions should be taken to avoid performance degradation or loss of functionality.

## PIN CONFIGURATION AND FUNCTION DESCRIPTIONS

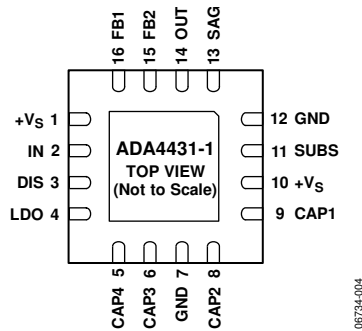

**NOTES**  
 1. EXPOSED PAD. THE EPAD IS ELECTRICALLY ISOLATED. TO OPTIMIZE THERMAL PERFORMANCE, CONNECT THE EPAD TO A GND PLANE.

Figure 4. Pin Configuration

Table 5. Pin Function Descriptions

Pin No.	Mnemonic	Description
1	+Vs	Supply Voltage.
2	IN	Video Input.
3	DIS	Disable Pin. High = charge pump on, floating = charge pump off, low = disabled.
4	LDO	Load Detect Output. High = video load present.
5	CAP4	Capacitor 2, Lead 2.
6	CAP3	Capacitor 2, Lead 1.
7	GND	Ground.
8	CAP2	Capacitor 1, Lead 2.
9	CAP1	Capacitor 1, Lead 1.
10	+Vs	Supply Voltage.
11	SUBS	Substrate Voltage Pin. Bypass to GND with 1.0 $\mu$ F capacitor.
12	GND	Ground.
13	SAG	SAG Feedback Pin.
14	OUT	Video Output.
15	FB2	Load Detect Feedback Pin 2. Connect to device side of series termination resistor.
16	FB1	Load Detect Feedback Pin 1. Connect to load side of series termination resistor.
	EPAD	Exposed Pad. The EPAD is electrically isolated. To optimize thermal performance, connect the EPAD to a GND plane.

# TYPICAL PERFORMANCE CHARACTERISTICS

$V_S = 3.0\text{ V}$  (@  $T_A = 25^\circ\text{C}$ ,  $V_{IN} = 1\text{ V p-p}$ ,  $R_L = 150\ \Omega$ , unless otherwise noted).

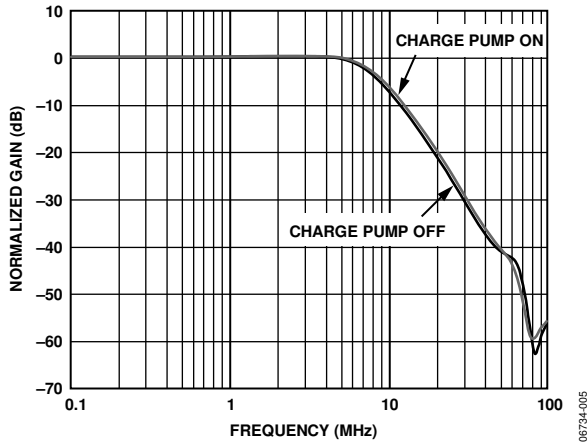

Figure 5. Large Signal Frequency Response

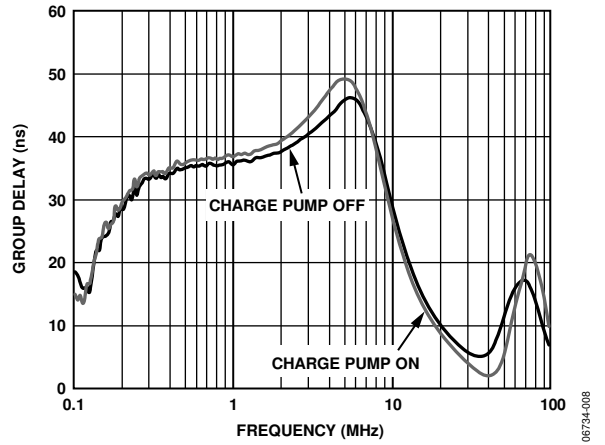

Figure 8. Group Delay vs. Frequency

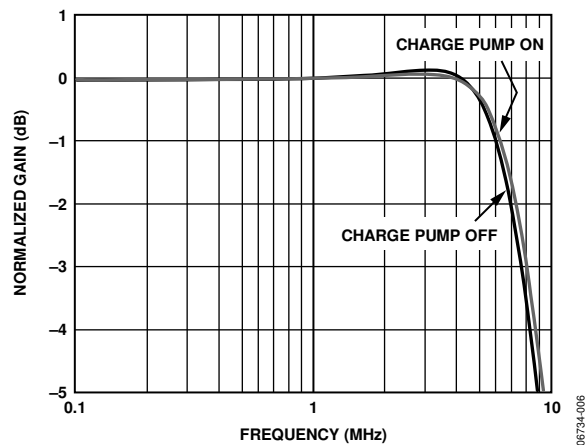

Figure 6. Frequency Response Flatness

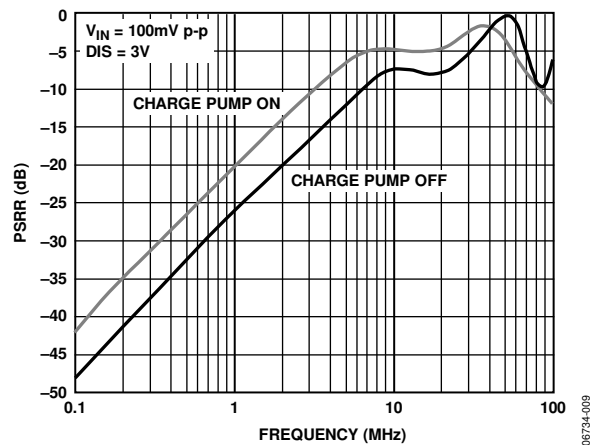

Figure 9. PSRR vs. Frequency

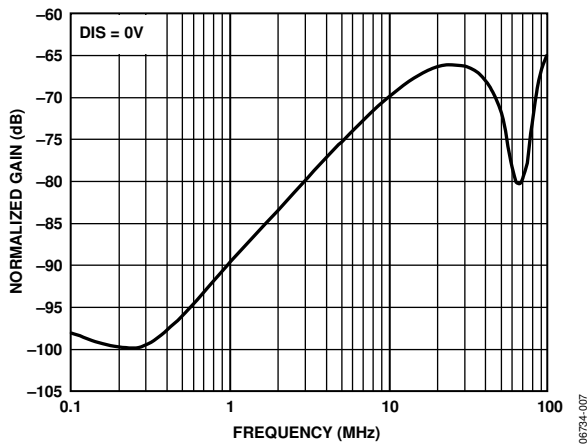

Figure 7. Input-to-Output Isolation vs. Frequency

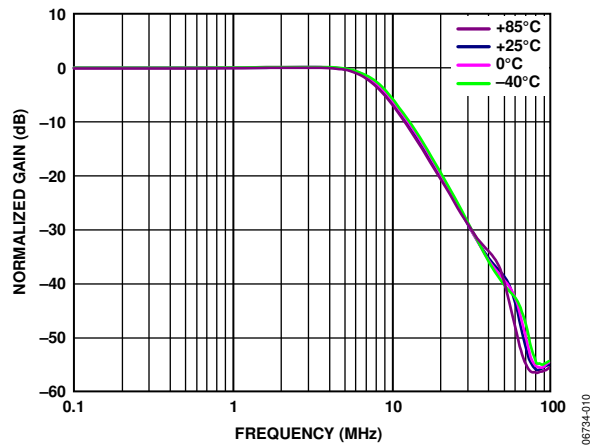

Figure 10. Frequency Response for Various Temperatures

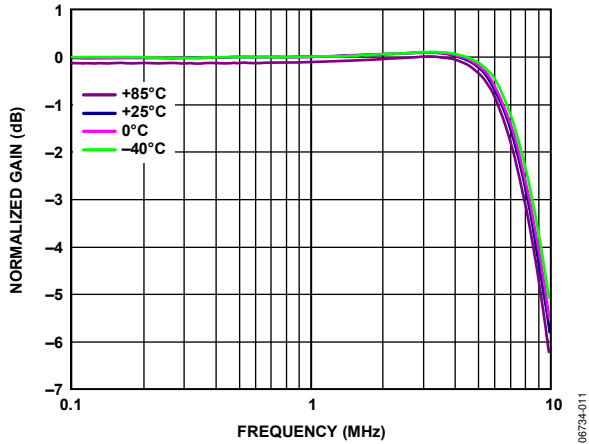

Figure 11. Flatness Response for Various Temperatures

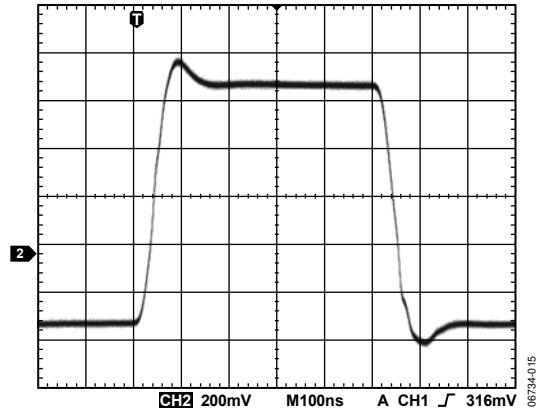

Figure 14. Transient Response

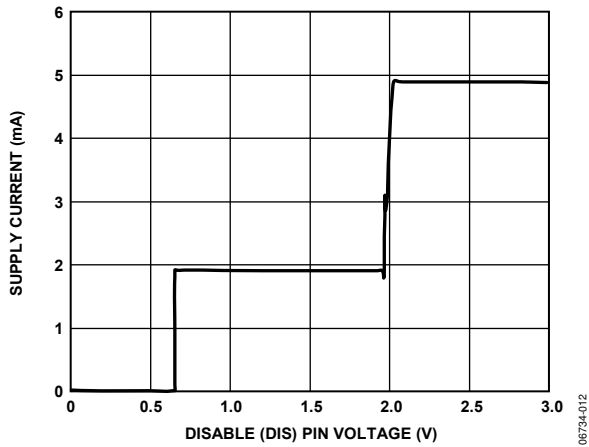

Figure 12. Supply Current vs. Disable (DIS) Pin Voltage

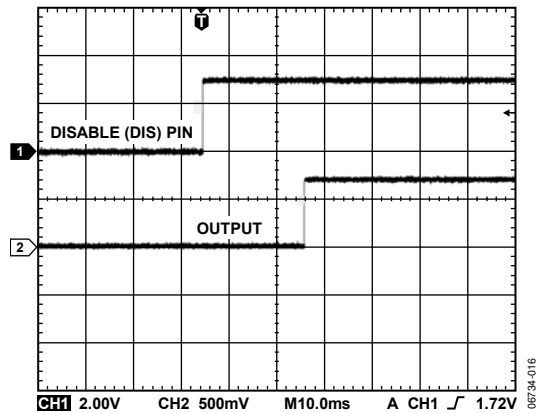

Figure 15. Output Enable

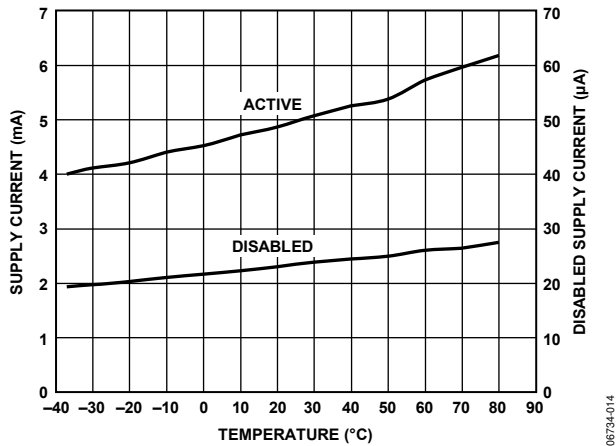

Figure 13. Supply Current vs. Temperature

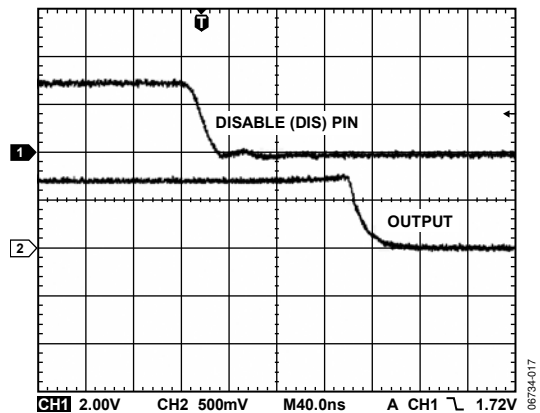

Figure 16. Output Disable



## THEORY OF OPERATION

### OVERVIEW

The [ADA4431-1](#) is designed for exceptional performance as both a filter and a low power driver for portable video applications. This performance is achieved by providing third-order filtering without trading off power consumption or device size. While consuming only 4.7 mA quiescent supply current, the [ADA4431-1](#) provides video output on a single-supply as low as 2.5 V.

The [ADA4431-1](#) also features a load detect circuit, which senses current through the external 75  $\Omega$  back-termination resistor. When either no video load or a short circuit is detected, the [ADA4431-1](#) enters a low power state. In this state, it draws 0.1 mA, continues to monitor the load current, and powers up automatically when a video load is connected. Optionally, the [ADA4431-1](#) can be powered down via the disable pin (DIS). Another external pin (LDO) outputs the load detection state (for example, to an external system controller). This pin is high (+V<sub>S</sub>) when a video load is present, and low (0 V) in the absence of a video load or when the output is short-circuited.

The [ADA4431-1](#) is intended for use in applications that have both ac- and dc-coupled inputs and outputs. The rail-to-rail buffer on the [ADA4431-1](#) output is able to drive 2 V p-p video signals into two doubly terminated video loads (150  $\Omega$  each) on a single 2.5 V supply. The [ADA4431-1](#) has a gain of 2 when the SAG correction pin is tied directly to the output, which makes up for the 6 dB termination loss (see Figure 17, Output Option 1). When the SAG feature is used, the [ADA4431-1](#) has a low frequency gain of 2.5 ( $\approx$ 8 dB) and a high frequency gain of 2 (see Figure 17, Output Option 2). Signal offsets and supply levels must be considered when using the SAG correction feature to ensure that there are no headroom issues.

The input range of the [ADA4431-1](#) includes ground, while the output range is limited by the saturation of the output devices. Saturation occurs several tens of mV from the positive and negative supply rails.

The high input impedance and low input capacitance of the [ADA4431-1](#) offer advantages in a number of low power applications. In reconstruction filter applications, the DAC can be placed in its lowest power mode, allowing the use of a large-valued load resistor. Using a large-valued load resistor does not interfere with the frequency response of the [ADA4431-1](#).

### CHARGE PUMP OPERATION

The on-board charge pump creates a virtual negative supply for the output driver, which allows the output signal to be dc-coupled, with its black level at 0 V and sync tip at  $-300$  mV. The charge pump is enabled whenever the disable pin (DIS) is held high. If DIS is left floating, or placed in a high impedance state, the [ADA4431-1](#) is powered up, but the charge pump is disabled, which is typically the case for ac-coupling of the output. When DIS is driven to 0 V, the entire device is powered down.

**Table 6. Disable (DIS) Pin Function Summary**

DIS Pin	Device State	Charge Pump State
Low	Disabled	Disabled
High	Enabled	Enabled
High-Z	Enabled	Disabled

### LOAD DETECT

The load detect feature provides additional system power management to keep the power consumption of a portable device to the absolute minimum. The [ADA4431-1](#) monitors the output load for three conditions: a normal load, a shorted load, and an open load. Each of these conditions occurs for a video load, an audio load, and no load, respectively. Only in the video load condition does the [ADA4431-1](#) power up from 0.1 mA to 4.7 mA. A single I/O pin, LDO, notifies the system by either being high for a video load or low for a short and open load. With this information, it is intended that the system controller power down any power intensive video processing blocks to realize substantial power savings. The [ADA4431-1](#) operates autonomously, requiring no inputs to monitor the condition of the output load.

## EVALUATION BOARD

The ADA4431-1 evaluation board allows designers to assess the performance of the part in their particular application. The board includes input and output SMA coaxial connectors and 75 Ω-controlled impedance signal traces. Power (2.5 V to 3.6 V) is applied to the red V+ loop connector, and ground is connected to the black GND loop connector.

The output signal can be configured for dc coupling or ac coupling. When ac-coupled, two options are available: the standard single capacitor configuration (minimum of 220 μF) and the SAG-corrected configuration, using two smaller capacitors (47 μF and 22 μF).

Jumper Block J2 allows the load detect feature to be evaluated without connecting an external video load. Connecting a jumper from the center pin to the 75 Ω position applies a 75 Ω load to the output and causes the LDO pin to go high.

Connecting the center pin to the GND position short circuits the output, causing the ADA4431-1 to power down, and the LDO pin to go low. If an external video load is connected to the OUT connector, the jumper should be removed. With the jumper removed, disconnecting the external load also causes the ADA4431-1 to power down.

Jumper Block J4 exercises the disable pin (DIS). When a jumper is connected from the center pin to V+, the charge pump is enabled. Connecting the center pin to GND forces the ADA4431-1 into low power mode. With the jumper removed, the ADA4431-1 is enabled but the charge pump is disabled.

A schematic of the ADA4431-1 evaluation board, with output coupling options, is shown in Figure 17. Figure 18 and Figure 19 show the front and back layout of the evaluation board.

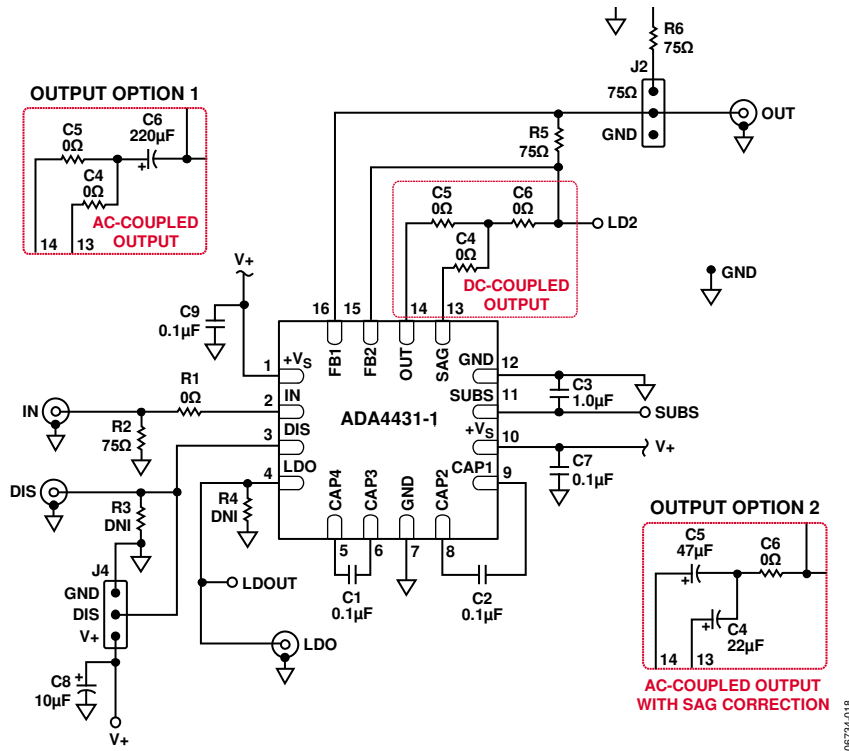
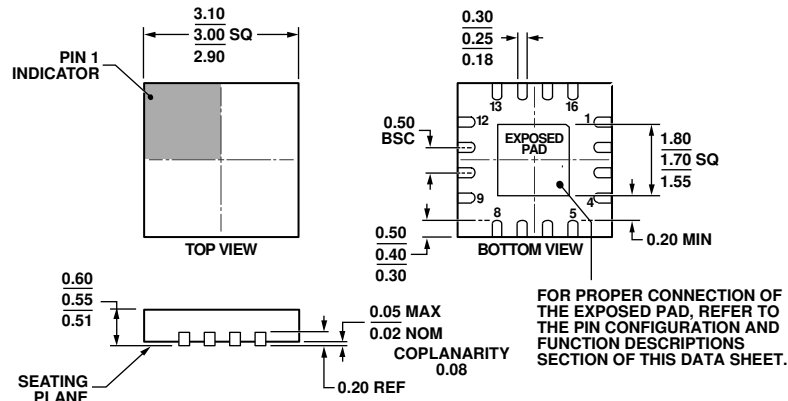

Figure 17. Evaluation Board Schematic



OUTLINE DIMENSIONS



COMPLIANT TO JEDEC STANDARDS MO-248-UEED.

Figure 20. 16-Lead Lead Frame Chip Scale Package [LFCSP\_UQ]  
 3 mm × 3 mm Body, Ultra Thin Quad  
 (CP-16-12)  
 Dimensions shown in millimeters

001600-C

ORDERING GUIDE

Model <sup>1</sup>	Temperature Range	Package Description	Package Option	Branding	Ordering Quantity
ADA4431-1YCPZ-R2	-40°C to +85°C	16-Lead LFCSP_UQ	CP-16-12	H12	250
ADA4431-1YCPZ-R7	-40°C to +85°C	16-Lead LFCSP_UQ	CP-16-12	H12	1,500
ADA4431-1YCPZ-RL	-40°C to +85°C	16-Lead LFCSP_UQ	CP-16-12	H12	5,000

<sup>1</sup> Z = RoHS Compliant Part.