



FocusLCDs.com
LCDs MADE SIMPLE®

Ph. 480-503-4295 | NOPP@FocusLCD.com

TFT | CHARACTER | UWVD | FSC | SEGMENT | CUSTOM | REPLACEMENT

Character Display Module

Part Number

C242ADBSGLY6WT55AIP

Overview

Character: 24x4(125x39), STN, Gray background, Yellow/Green LED, Bottom view, Wide temp, Transflective (positive), 5V LCD, 5V LED, Controller=AIP31066, RoHS Compliant

2. MECHANICAL CHARACTERISTICS

2.1 MECHANICAL DATA

ITEM	STANDARD VALUE	UNIT
NUMBER OF CHARACTERS	24(CHARACTERS) X 4(LINES)	
OUTLINE DIMENSIONS	125.0(W) X 39.0(H) X 14.0(T)	mm
EFFECTIVE VIEWING AREA	97.0(W) X 27.0(H)	mm
ACTIVE AREA	88.3(W) X 23.4(H)	mm
CHARACTER SIZE	3.20(W) X 5.55(H)	mm
CHARACTER PITCH	3.70(W) X 5.95(H)	mm
APPROX WEIGHT	150	g

2.2 MECHANICAL DRAWINGS

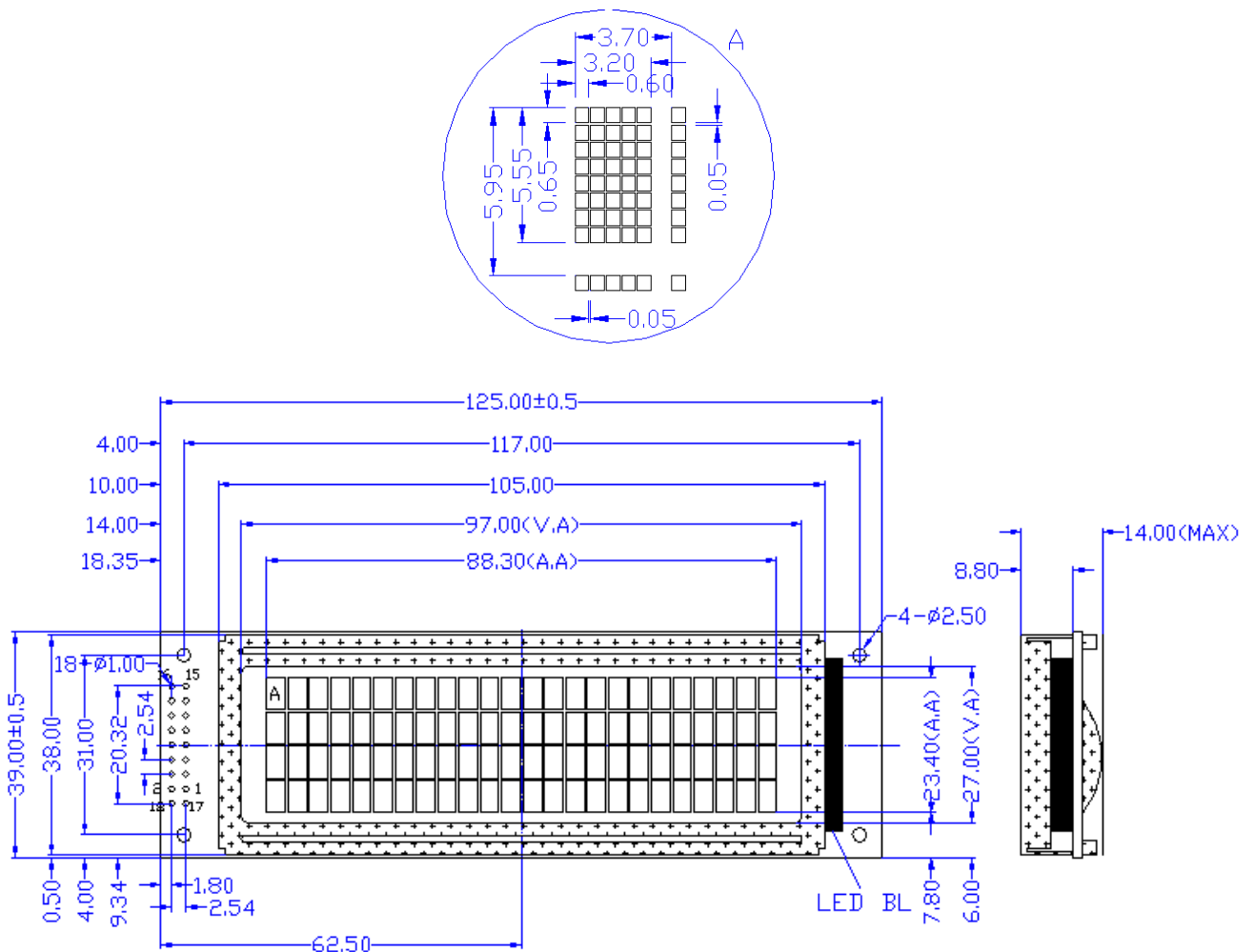

3. CIRCUIT BLOCK DIAGRAM

3.1 Electrical Block Diagram

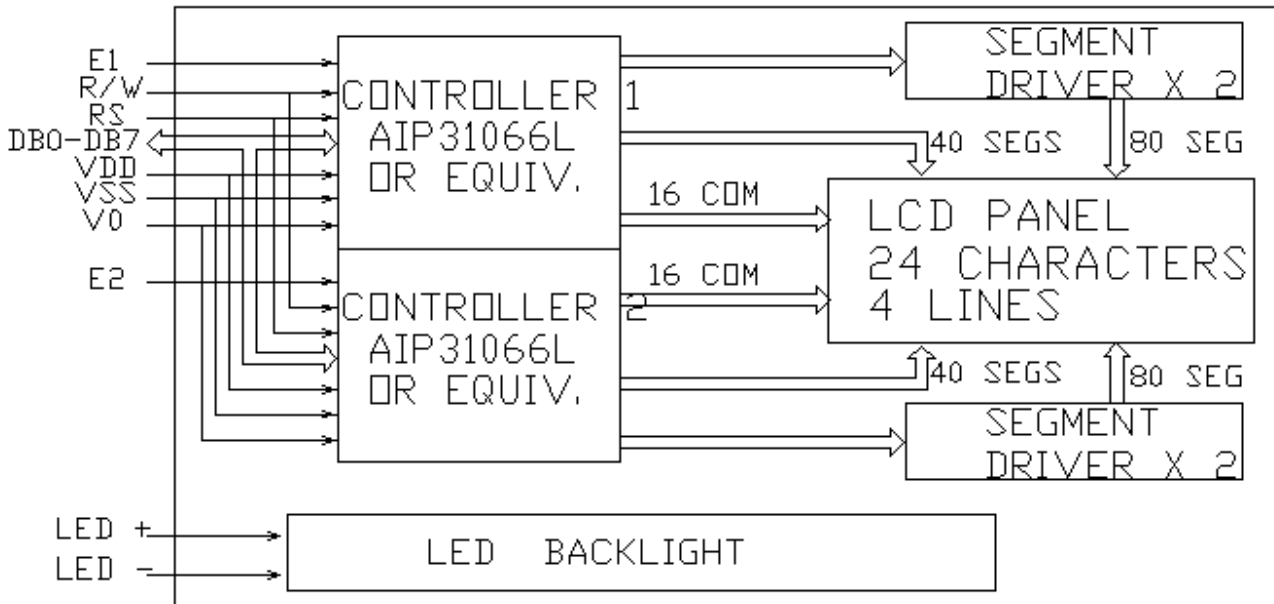

3.2 Pins Definition

PIN	SYMBOL	FUNCTION
1	Vss	Power Supply(GND)
2	Vdd	Power Supply(+5V)
3	Vo	Contrast Adjust
4	RS	Instruction/Data Register Select
5	R/W	Data Bus Line
6	E1	Enable Signal For Controller1
7-14	DB0-DB7	Data Bus Line
15	LEDA	Power Supply for LED B/L(+5V)
16	LEDK	Power Supply for LED B/L(-)
17	Vss	Power Supply(GND)
18	E2	Enable Signal For Controller2

3.3 Power Supply For LCM Driving

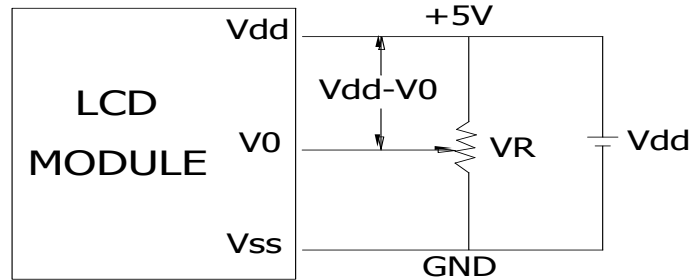

Vdd-V0: LCD Driving Voltage
 VR: 10K - 20K

3.4 Display Character Address Code

Display position	1	2	3	4	5	-----	20	21	22	23	24	USE E1 ENABLE
DDRAM	80	81	82	83	84		93	94	95	96	97	
ADDRESS	C0	C1	C2	C3	C4		D3	D4	D5	D6	D7	

Display position	1	2	3	4	5	-----	20	21	22	23	24	USE E2 ENABLE
DDRAM	80	81	82	83	84		93	94	95	96	97	
ADDRESS	C0	C1	C2	C3	C4		D3	D4	D5	D6	D7	

*NOTE: ALL OF THE NUMBERS ARE IN HEX FORMAT

4. ABSOLUTE MAXIMUM RATINGS

4.1 Electrical Absolute Maximum Ratings

ITEM	SYMBOL	CONDITION	MIN	MAX	UNIT
Operating Voltage	Vdd	-	+0.3	+7.0	V
Supply Voltage	V0	-	0.3	+17.05	V
Supply Voltage	V1,V2,V3,V4	-	0.3	V0	V
Input Voltage	Vi	-	-0.3	Vdd +0.3	V
Output Voltage	Vo	-	-0.3	Vdd+0.3	V

4.2 Environmental Absolute Maximum Ratings

ITEM	SYMBOL	CONDITIONS	MIN	MAX	UNIT
Operating Temp	Top	Extended temp. version	0	50	deg C
Storage Temp	Tst		-20	70	deg C
Humidity Endurance	RH	no condensation Ta<=40 deg	-	95	%
Vibration	-	100-300Hz, X/Y/Z directions, 1 hour	-	4.9m/ss 0.5g	-
Shock	-	10 mS X/Y/Z direction 1 time each		29.4m/ss 3.0g	-

5. ELECTRICAL CHARACTERISTICS

5.1 DC Characteristics

Electrical Characteristics at Ta=25 deg C, Vdd =5.0V + / -10%, VSS=0V

ITEM	SYMBOL	CONDITION	MIN	TYP	MAX	UNIT
Supply Voltage (logic)	Vdd-Vss	Ta=25°C	4.75	5.0	5.25	V
Supply Voltage for LCD	Vlcd	Ta=25°C	4.0	4.5	5.0	V
Input Signal Voltage	V-ih	"H" level	0.8Vdd	-	Vdd	V
	V-il	"L" level	Vss	-	0.2Vdd	V
Supply current	Idd	Vdd=5.0V	-	1.0	1.5	mA

5.2 AC Characteristics

TIMING SPECIFICATIONS at Ta = 25 deg C, Vdd = 5V+/-10%, Vss =0V

For Write mode

ITEM	SYMBOL	MIN	MAX	UNIT
E cycle time	tc	500	-	ns
E rise time	tR	-	25	ns
E fall time	tF	-	25	ns
E-pulse width (H, L)	tw	220	-	ns
R/W and RS set-up time	tsul	40	-	ns
R/W and RS hold time	tH1	10	-	ns
Data set-up time	tsu2	60	-	ns
Data hold time	tH2	10	-	ns

For Read mode

ITEM	SYMBOL	MIN	MAX	UNIT
E cycle time	tc	500	-	ns
E rise time	tR	-	25	ns
E fall time	tF	-	25	ns
E-pulse width (H, L)	tw	220	-	ns
R/W and RS set-up time	tsu	40	-	ns
R/W and RS hold time	tH	10	-	ns
Data output delay	tD	-	120	ns
Data hold time	tDH	20	-	ns

WRITE MODE TIMING DIAGRAM

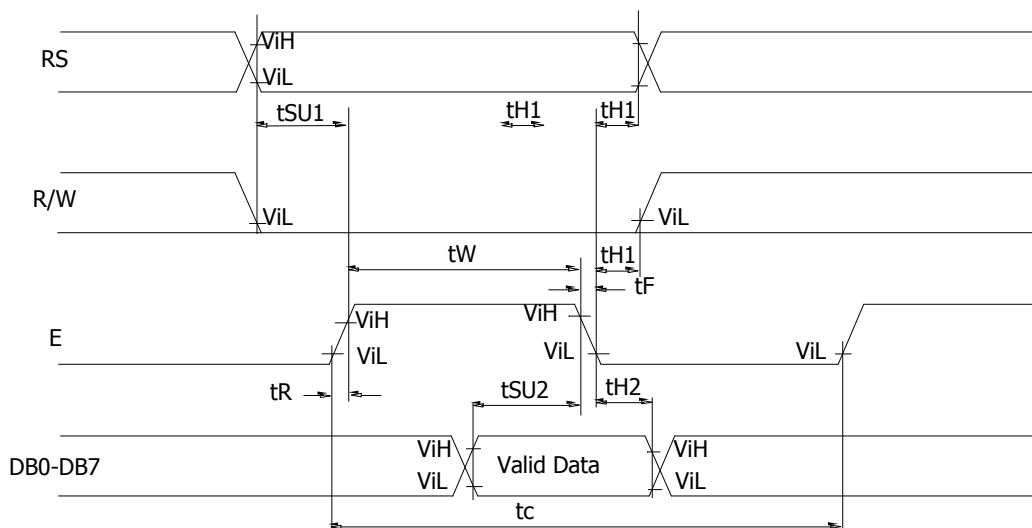

READ MODE TIMING DIAGRAM

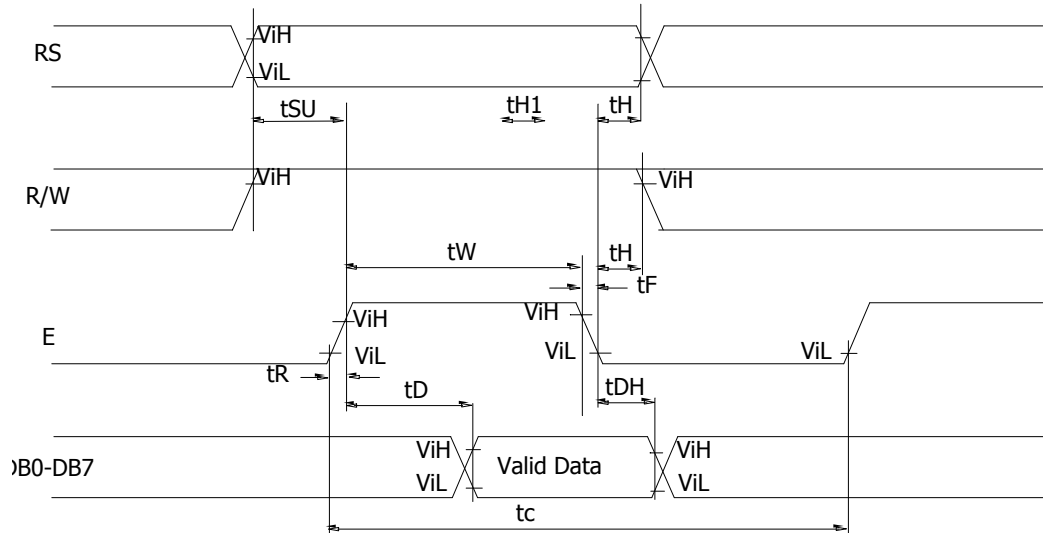

6. BACKLIGHT CHARACTERISTICS

ITEM	SYMBOL	CONDITION	MIN.	TYP.	MAX.	UNIT
Forward Voltage	V_f^*		4.7	5.0	5.2	V
Forward Current	I_f	$V_f=5.0V$	-	60	-	mA
Reverse Voltage	V_r	-	-	-	8	V
Peak Wave Length	λ_P	$V_f=5.0V$	-	682(WHITE)	-	nm
Power Dissipation	P_d	$V_f=5.0V$	-	250	-	mW

* V_f is the voltage applied to LEDA and LEDK



LED CIRCUIT DIAGAM(LED 1X3=3 dies)

7. ELECTRO-OPTICAL CHARACTERISTICS

ITEM	SYMBOL	CONDITION	MIN.	TYP.	MAX.	UNIT	REF.
Contrast	CR	25°C	4	--	--		Note1
Rise Time	tr	25°C	--	160	240	ms	Note2
Fall Time	tf	25°C	--	100	150	ms	note 2
Viewing Angle	θ 1- θ 2 \emptyset 1, \emptyset 2	25°C	-- -40	--	60 40	DEG	Note 3
Frame Frequency	Ff	25°C	--	70	--	Hz	note 2

Note(1): Contrast ratio is defined under the following condition:

- CR= $\frac{\text{brightness of selected condition}}{\text{brightness of non-selected condition}}$
- Temperature-----25C
 - Frame Frequency-----64Hz
 - Viewing angle----- $\theta = 0, \emptyset = 0$
 - Operating Voltage---5.0V

Note(2): definition of response time:

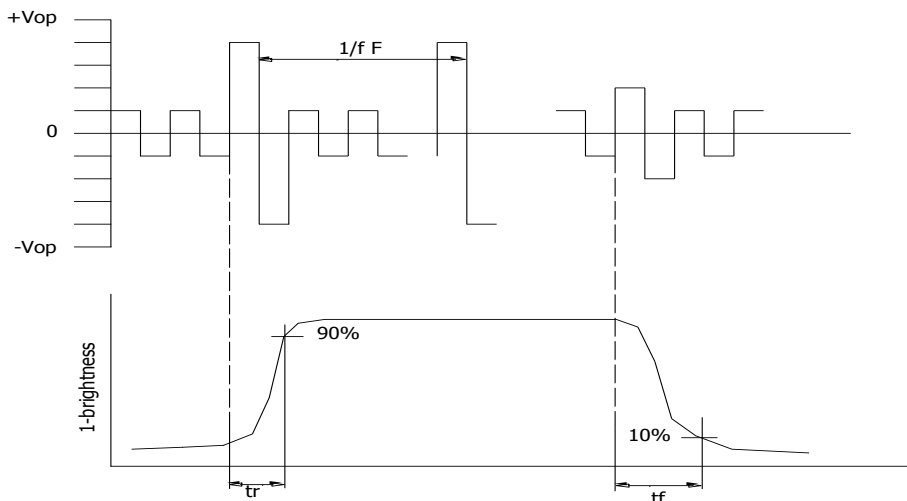

Condition:

- Temperature-----25C
- Frame Frequency-----64Hz
- Viewing angle----- $\theta = 0, \emptyset = 0$
- Operating Voltage---5.0V

Note(3): definition of view angle:

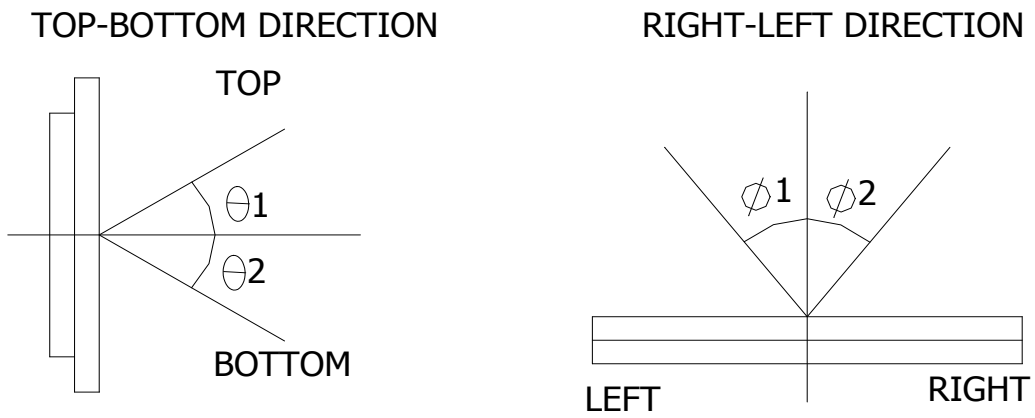

8. DISPLAY CONTROL INSTRUCTION

8.1 INSTRUCTION TABLE

Function	R	F	DD	DD	DD	DD	DD	DD	DD	Description	Execu Time* (Max)		
	SW	B	B	B	B	B	B	B	B				
			7	6	5	4	3	2	1	0			
Clear Display	0	0	0	0	0	0	0	0	0	1	Clears entire display and returns the cursor to home position (address 0)	1.64mS	
Return Home	0	0	0	0	0	0	0	0	0	1	X	Return the cursor to the home position. DD RAM contents remain unchanged. Set DD RAM address to zero.	1.64mS
Entry mode set	0	0	0	0	0	0	0	0	1	1	S	Set cursor moving direction and enable the shift of the display. These operations are performed during data write/read of DD RAM/CG RAM. 1/D=1: increment; 1/D=0: decrement; S=1: whole display shift when data is written.	40μS
Display ON/OFF control	0	0	0	0	0	0	0	1	D	C	B	Set display (D), cursor (C) and blinking of cursor (B) ON/OFF. D=1: display ON; D=0: display OFF. C=1: Cursor ON; C=0: cursor OFF. B=1: Blink ON; B=0, Blink OFF.	40μS
Cursor or Display shift	0	0	0	0	0	1	S	R	X	X	X	Move the cursor and shift the display without changing DDRAM contents. S/C=1: Display Shift; S/C=0: Cursor move. R/L=1: shift to right; R/L=0: shift to left.	40μS
Function Set	0	0	0	0	1	D	N	F	X	X	X	Set interface data length (DL), number of display lines (N) and character font (F). DL=1: 8 bits; DL=0: 4 bits. N=1: 2 lines; N=0: 1 lines. F=1: 5X11 dots; F=0: 5X7 dots.	40μS
Set CG RAM add	0	0	0	1	ACG							Set CG RAM address. CG RAM data is sent and received after this setting.	40μS
Set DD RAM Add	0	0	1	ADD								Set DD RAM address. DD RAM data is sent and received after this setting.	40μS
Read BF & Addr	0	1	B	AC								Read BUSY FLAG (BF) and the contents of the address counter. BF=1: internal operation; BF=0: can accept instruction.	0μS
Write Data to RAM	1	0	WRITE DATA									Write data into DD RAM or CG RAM.	40 μS**
Read Data from RAM	1	0	READ DATA									Read data from DD RAM or CG RAM.	40 μS**

8.2 Character code

Upper 4 bit Lower 4 bit	0000	0001	0010	0011	0100	0101	0110	0111	1000	1001	1010	1011	1100	1101	1110	1111
1111				0	1	2	3	4	5	6	7	8	9	A	B	C
1110			!	1	2	3	4	5	6	7	8	9	A	B	C	D
1101			"	1	2	3	4	5	6	7	8	9	A	B	C	D
1100			#	1	2	3	4	5	6	7	8	9	A	B	C	D
1011			\$	1	2	3	4	5	6	7	8	9	A	B	C	D
1010			%	1	2	3	4	5	6	7	8	9	A	B	C	D
1001			&	1	2	3	4	5	6	7	8	9	A	B	C	D
1000			'	1	2	3	4	5	6	7	8	9	A	B	C	D
0111			(1	2	3	4	5	6	7	8	9	A	B	C	D
0110)	1	2	3	4	5	6	7	8	9	A	B	C	D
0101			*	1	2	3	4	5	6	7	8	9	A	B	C	D
0100			+	1	2	3	4	5	6	7	8	9	A	B	C	D
0011			,	1	2	3	4	5	6	7	8	9	A	B	C	D
0010			=	1	2	3	4	5	6	7	8	9	A	B	C	D
0001			.	1	2	3	4	5	6	7	8	9	A	B	C	D
0000			/	0	1	2	3	4	5	6	7	8	9	A	B	C

9. INSPECTION STANDARDS

9.1 Inspection Conditions

The LCD shall be inspected under 40W white fluorescent light.

The distance between the eyes and the samples shall be more than 30cm.

All directions for inspecting the sample should be within 45 degree against perpendicular line.

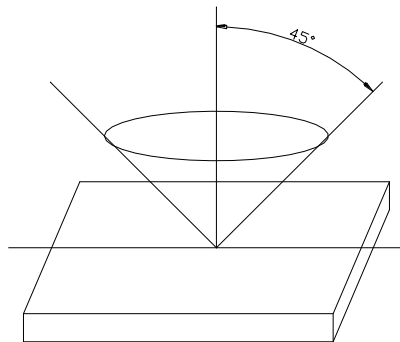

9.2 Definition of Applicable Zone

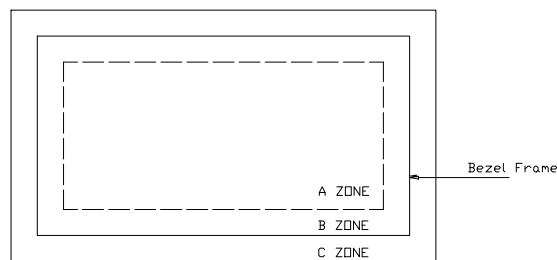

A Zone: Active Display Area

B Zone: Area from Bezel Frame to A Zone

C Zone: Rest Area of Bezel

A Zone + B Zone=Effective Viewing Area

9.3 Standards

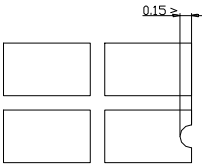
NO	PARAMETER	CRITERIA																																	
1	Black and White Spots, Foreign Substances	Round Shape <table border="1"> <thead> <tr> <th rowspan="2">Zone DIMENSION(MM)</th> <th colspan="3">Acceptable Number</th> </tr> <tr> <th>A</th> <th>B</th> <th>C</th> </tr> </thead> <tbody> <tr> <td>D≤0.1</td> <td>*</td> <td>*</td> <td>*</td> </tr> <tr> <td>0.1<D≤0.2</td> <td>5</td> <td>5</td> <td>*</td> </tr> <tr> <td>0.2<D≤0.3</td> <td>0</td> <td>1</td> <td>*</td> </tr> <tr> <td>0.3<D</td> <td>0</td> <td>0</td> <td>*</td> </tr> </tbody> </table> <p>D=(long+short)/2 * Disregard</p>	Zone DIMENSION(MM)	Acceptable Number			A	B	C	D≤0.1	*	*	*	0.1<D≤0.2	5	5	*	0.2<D≤0.3	0	1	*	0.3<D	0	0	*										
		Zone DIMENSION(MM)		Acceptable Number																															
A	B		C																																
D≤0.1	*	*	*																																
0.1<D≤0.2	5	5	*																																
0.2<D≤0.3	0	1	*																																
0.3<D	0	0	*																																
		Line Shape <table border="1"> <thead> <tr> <th rowspan="2">X(mm) \ Y(mm)</th> <th rowspan="2">Zone</th> <th colspan="3">Acceptable Number</th> </tr> <tr> <th>A</th> <th>B</th> <th>C</th> </tr> </thead> <tbody> <tr> <td>- \ 0.02≥W</td> <td></td> <td>*</td> <td>*</td> <td>*</td> </tr> <tr> <td>2.0≥L \ 0.03≥W</td> <td></td> <td>3</td> <td>3</td> <td>*</td> </tr> <tr> <td>1.0≥L \ 0.04≥W</td> <td></td> <td>1</td> <td>2</td> <td>*</td> </tr> <tr> <td>1.0≥L \ 0.05≥W</td> <td></td> <td>0</td> <td>2</td> <td>*</td> </tr> <tr> <td>- \ 0.05<W</td> <td></td> <td colspan="3">Not acceptable</td> </tr> </tbody> </table> <p>X: Length Y: Width * Disregard Total defects shall not exceed 5.</p>	X(mm) \ Y(mm)	Zone	Acceptable Number			A	B	C	- \ 0.02≥W		*	*	*	2.0≥L \ 0.03≥W		3	3	*	1.0≥L \ 0.04≥W		1	2	*	1.0≥L \ 0.05≥W		0	2	*	- \ 0.05<W		Not acceptable		
X(mm) \ Y(mm)	Zone	Acceptable Number																																	
		A	B	C																															
- \ 0.02≥W		*	*	*																															
2.0≥L \ 0.03≥W		3	3	*																															
1.0≥L \ 0.04≥W		1	2	*																															
1.0≥L \ 0.05≥W		0	2	*																															
- \ 0.05<W		Not acceptable																																	
2	Air Bubbles (Between glass and polarizer)	<table border="1"> <thead> <tr> <th rowspan="2">Dimension(mm)</th> <th rowspan="2">Zone</th> <th colspan="3">Acceptable Number</th> </tr> <tr> <th>A</th> <th>B</th> <th>C</th> </tr> </thead> <tbody> <tr> <td>D≤0.1</td> <td></td> <td>*</td> <td>*</td> <td>*</td> </tr> <tr> <td>0.1<D≤0.2</td> <td></td> <td>5</td> <td>5</td> <td>*</td> </tr> <tr> <td>0.2<D≤0.3</td> <td></td> <td>0</td> <td>1</td> <td>*</td> </tr> <tr> <td>0.3<D</td> <td></td> <td>0</td> <td>0</td> <td>*</td> </tr> </tbody> </table> <p>*: Disregard Total defects shall not exceed 3.</p>	Dimension(mm)	Zone	Acceptable Number			A	B	C	D≤0.1		*	*	*	0.1<D≤0.2		5	5	*	0.2<D≤0.3		0	1	*	0.3<D		0	0	*					
Dimension(mm)	Zone	Acceptable Number																																	
		A	B	C																															
D≤0.1		*	*	*																															
0.1<D≤0.2		5	5	*																															
0.2<D≤0.3		0	1	*																															
0.3<D		0	0	*																															
3	The Shape of Dot	<p>(1) Dot Shape(with dent)</p>  <p>As per the sketch of left hand.</p> <p>(2) Dot Shape(with Projection)</p>																																	

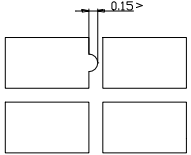
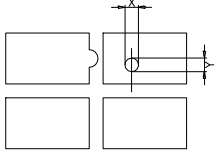
		 <p>Should not connect to next dot.</p> <p>(3) Pin Hole</p>  <p>$(X+Y)/2 < 0.2\text{mm}$ (less than 0.1mm is not counted)</p> <p>Total defects shall not exceed 5.</p>
4	Polarizer Scratches	Not to be conspicuous defects.
5	Polarizer Dirts	If the stains are removed easily from LCD surface, the module is not defective.
6	Color Variation	Not to be conspicuous defects.

10. PRECAUTIONS IN USING LCM

1. LIQUID CRYSTAL DISPLAY (LCD)

LCD is made up of glass, organic sealant, organic fluid, and polymer based polarizers. The following precautions should be taken when handling,

- (1). Keep the temperature within range of use and storage. Excessive temperature and humidity could cause polarization degradation, polarizer peel off or bubble.
- (2). Do not contact the exposed polarizers with anything harder than an HB pencil lead. To clean dust off the display surface. Wipe gently with cotton. Chamois or other soft material soaked in petroleum benzin.
- (3). Wipe off saliva or water drops immediately. Contact with water over a long period of time may cause polarizer deformation or color fading, while an active LCD with water condensation on its surface will cause corrosion of ITO electrodes.
- (4). Glass can be easily chipped or cracked from rough handling. especially at corners and edges.
- (5). Do not drive LCD with DC voltage.

2. Liquid Crystal Display Modules

2.1 Mechanical Considerations

LCM are assembled and adjusted with a high degree of precision. Avoid excessive shocks and do not make any alterations or modifications. The following should be noted.

- (1). Do not tamper in any way with the tabs on the tabs on the metal frame.
- (2). Do not modify the PCB by drilling extra holes, changing its outline, moving its

components or modifying its pattern.

(3). Do not touch the elastomer connector, especially insert an backlight panel (for example, EL).

(4). When mounting a LCM make sure that the PCB is not under any tress such as bending or twisting. Elastomer contacts are very delicate and missing pixels could result from slight dislocation of any of the elements.

(5). Avoid pressing on the metal bezel, otherwise the elastomer connector could be deformed and lose contact, resulting in missing pixels.

2.2. Static Electricity

LCM contains CMOS LSI's and the same precaution for such devices should apply, namely

(1). The operator should be grounded whenever he/she comes into contact with the module. Never touch any of the conductive parts such as the LSI pads, the copper leads on the PCB and the interface terminals with any parts of the human body.

(2). The modules should be kept in antistatic bags or other containers resistant to static for storage.

(3). Only properly grounded soldering irons should be used.

(4). If an electric screwdriver is used, it should be well grounded and shielded from commutator sparks.

(5). The normal static prevention measures should be observed for work clothes and working benches; for the latter conductive (rubber) mat is recommended.

(6). Since dry air is inductive to statics, a relative humidity of 50-60% is recommended.

2.3. Soldering

(1). Solder only to the I/O terminals.

(2). Use only soldering irons with proper grounding and no leakage.

(3). Soldering temperature: $280\text{ }^{\circ}\text{C} \pm 10^{\circ}\text{C}$

(4). Soldering time: 3 to 4 sec.

(5). Use eutectic solder with resin flux fill.

(6). If flux is used, the LCD surface should be covered to avoid flux spatters. Flux residue should be removed after wards.

2.4. Operation

(1). The viewing angle can be adjusted by varying the LCD driving voltage V0.

(2). Driving voltage should be kept within specified range; excess voltage shortens display life.

(3). Response time increases with decrease in temperature.

(4). Display may turn black or dark blue at temperatures above its operational range; this is (however not pressing on the viewing area) may cause the segments to appear "fractured".

(5). Mechanical disturbance during operation (such as pressing on the viewing area) nay cause the segments to appear "fractured".

2.5. Storage

If any fluid leaks out of a damaged glass cell, wash off any human part that comes into contact with soap and water. Never swallow the fluid. The toxicity is extremely low but caution should be exercised at all the time.