

DESCRIPTION

The MP3309A is a WLED step-up converter for 2.7V-to-5.5V input that uses peak-current mode to regulate the LED current sensed through an external low-side resistor. The 200mV feedback voltage and synchronous rectification reduces power loss and reduces PCB space requirements. To connect an external Schottky accomplishes the non-synchronous mode for heavy load to improve the thermal performance.

The MP3309A features a programmable switching frequency to optimize efficiency. It supports both analog and PWM dimming.

In addition, the MP3309A has LED open protection, cycle-by-cycle current limit protection and thermal shutdown protection. The I²C interface can set the over-voltage protection threshold, analog dimming and read IC status. MP3309A is available in QFN10 3*3mm package.

ELECTRICAL SPECIFICATIONS

Parameter	Symbol	Value	Units
Input Voltage	V _{IN}	2.7-5.5	V
Output Voltage	V _{LED}	<35	V
LED Current	I _{LED}	40	mA

FEATURES

- 2.7V-to-5.5V Input Voltage
- Low 200mV Feedback Voltage with ±1% Accuracy
- Selectable Synchronous or Non-synchronous Mode Thru I²C
- 400kHz I²C-Compatible Interface
- Analog and PWM Dimming
- Programmable Switching Frequency
- Programmable Over Voltage Protection Point
- Software- or Hardware-Enable Function
- UVLO, Thermal Shutdown
- Available in 3×3mm QFN 10 package

APPLICATIONS

- Feature Phones and Smart Phones
- Tablets
- Video Displays

All MPS parts are lead-free, halogen free, and adhere to the RoHS directive. For MPS green status, please visit MPS website under Quality Assurance.

"MPS" and "The Future of Analog IC Technology" are Registered Trademarks of Monolithic Power Systems, Inc.

EV3309A-Q-00A EVALUATION BOARD



(L x W x H) 5cm x 4.6cm x 1.0cm

Board Number	MPS IC Number
EV3309A-Q-00A	MP3309AGQ

EVALUATION BOARD SCHEMATIC

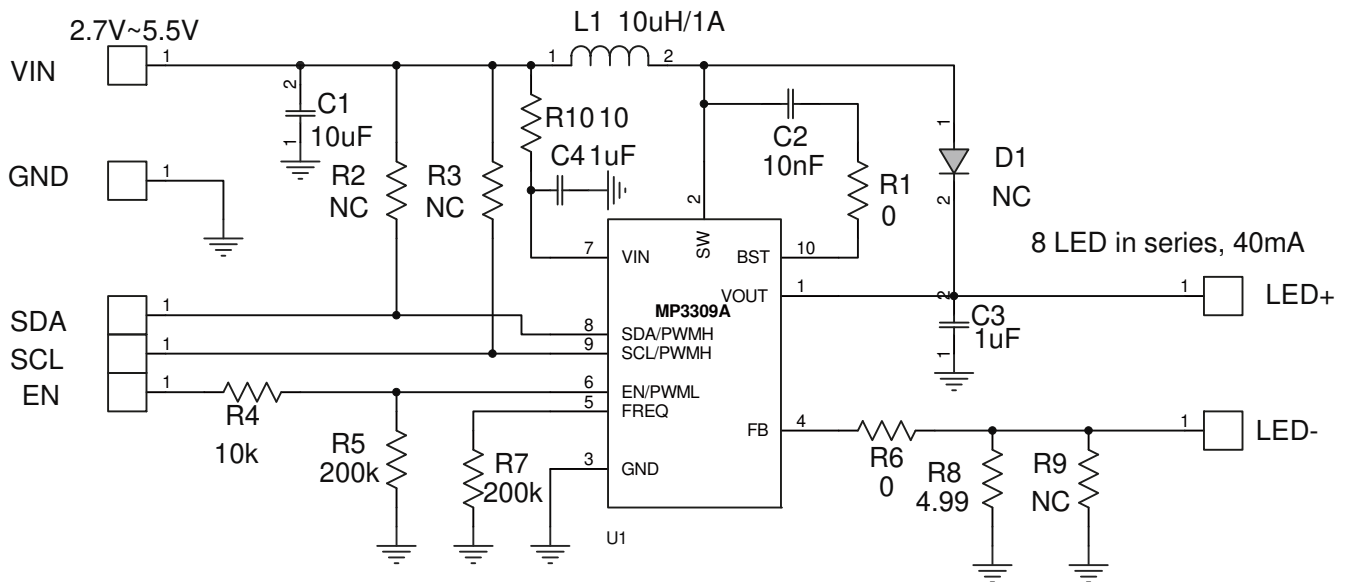

EV3309A-Q-00A BILL OF MATERIALS

Qty	Ref	Value	Description	Package	Manufacturer	Part Number
1	C1	10uF	Ceramic Capacitor, 6.3V, X7R	0805	muRata	GCM21BR70J106KE2
1	C2	10nF	Ceramic Capacitor, 50V, X7R	0603	muRata	GRM188R71H103KA01D
1	C3	1uF	Ceramic Capacitor, 50V, X7R	1206	muRata	GRM31MR71H105KA88L
1	C4	1uF	Ceramic Capacitor, 6.3V, X5R	0603	muRata	GRM188R60T105KA01D
1	D1	NC				
1	L1	10uH	Inductor, 1.14A, DCR=59mOhm	SMD	TOKO	D63LCB-A921CY- 100M=P3
2	R1,R6	0Ohm	Resister, 0Ohm, 5%	0603	Yageo	RC0603JR-070RL
1	R10	10Ohm	Resister, 10Ohm, 1%	0603	Yageo	RC0603FR-0710RL
3	R2, R3, R9	NC				
2	R5,R7	200kOhm	Resister, 200kOhm, 1%	0603	Yageo	RC0603FR-07200KL
1	R4	10kOhm	Resister, 10kOhm, 1%	0603	Yageo	RC0603FR-0710KL
1	R8	4.99Ohm	Resister, 4.99Ohm, 1%	0603	Yageo	RC0603FR-074R99L
1	U1	MP3309AGQ		QFN10(3*3)	MPS	

EVB TEST RESULTS

Performance waveforms are tested on the evaluation board.

$V_{IN} = 3.6V$, 8 LEDs in series, $I_{LED} = 40mA$, $L = 10\mu H$, $T_A = 25^\circ C$, unless otherwise noted.

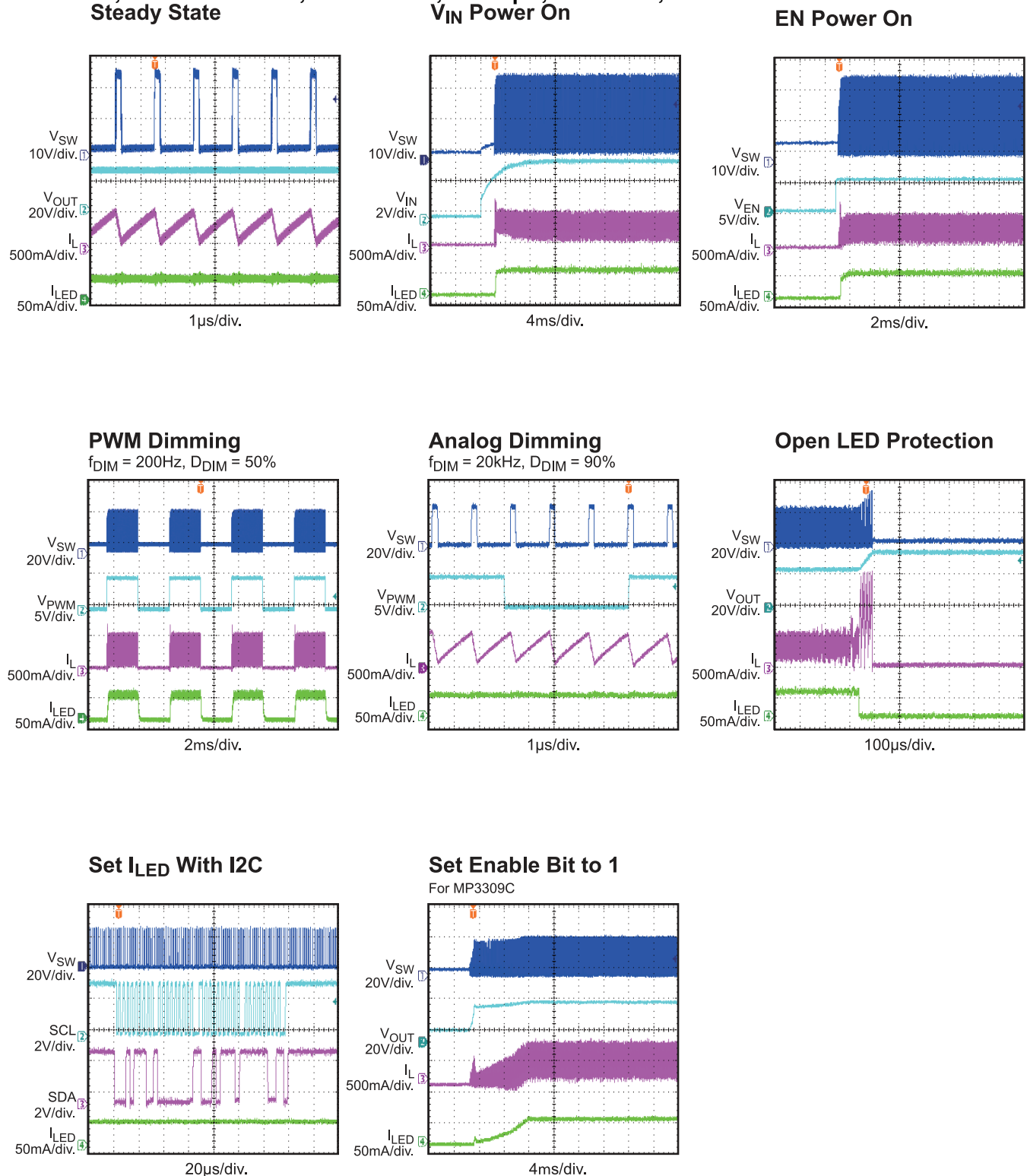

PRINTED CIRCUIT BOARD LAYOUT

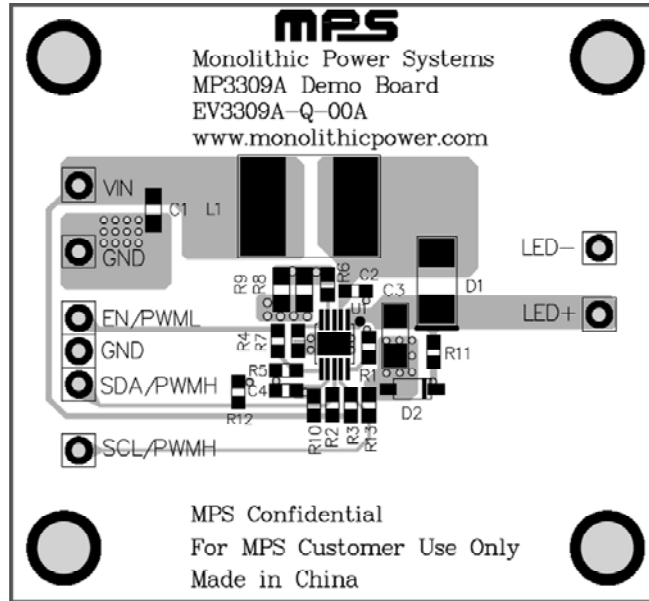

Figure 1—Top Layer

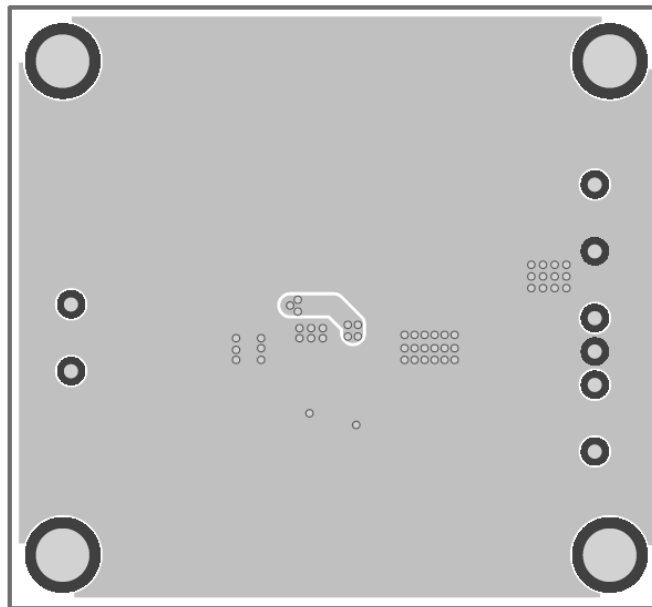

Figure 2—Bottom Layer

QUICK START GUIDE

1. Provide a voltage source ranges from 2.7-5.5V between VIN terminal and GND.
2. Connect LED strings between LED+ and LED-.
3. Dimming Mode

Analog Dimming:

Firstly pull EN/PWML pin to logical high, then connect SCL/PWMH and SDA/PWMH pin together and add >20kHz PWM signal.

PWM Dimming:

Firstly connect SCL/PWMH and SDA/PWMH together and pull to logical high, then add 200-2kHz PWM signal to EN/PWML pin.

4. According output current select feedback resistor at FB pin(resister-current calculation equation as datasheet).

NOTICE: The information in this document is subject to change without notice. Please contact MPS for current specifications. Users should warrant and guarantee that third party Intellectual Property rights are not infringed upon when integrating MPS products into any application. MPS will not assume any legal responsibility for any said applications.