

REVISIONS					
REV	ECO	DESCRIPTION	DATE	BY	APPR
A1	-	FIRST RELEASE	APR.13,2016	Drack	Tommy
A2	-	UPDATE DRAWING	Oct.30,2017	White	Tommy

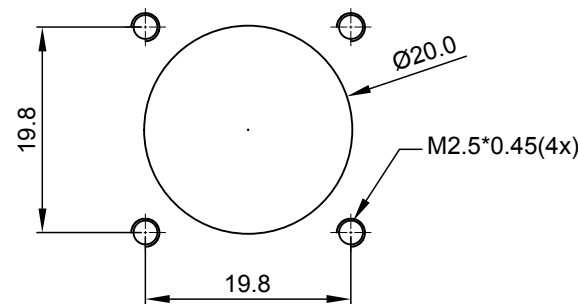
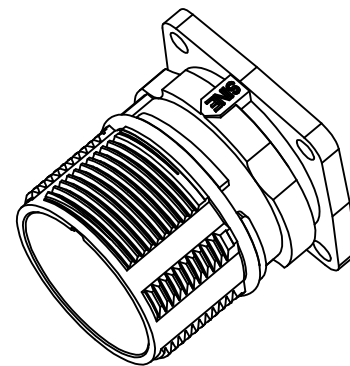
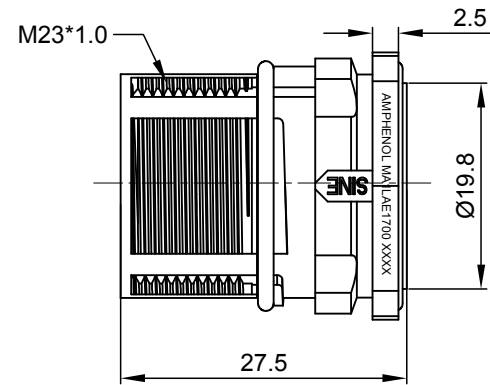
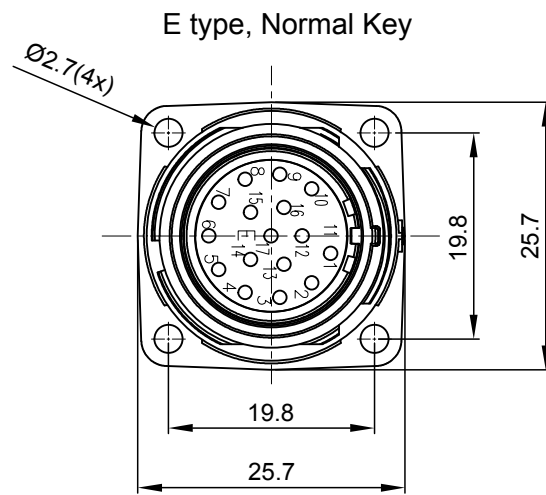

NOTES: UNLESS OTHERWISE SPECIFIED

- MATERIAL:
 - INSULATION INSERT: PA66,UL94 V0
 - SEAL: VITON
 - HOUSING BODY: ZINC DIE CAST, NICKEL PLATED
 - CONTACT: COPPER ALLOY, GOLD PLATED
- SPECIFICATIONS:
 - 2.1 CURRENT RATING: 9 AMPS
 - 2.2 VOLTAGE RATING: 125 V AC/DC
 - 2.3 CONTACT RESISTANCE: <5 mOHMS
 - 2.4 OPERATING TEMPERATURE: -20°C TO +130°C
 - 2.5 DIELECTRIC WITHSTANDING VOLTAGE: LESS THAN 2 MILLIAMPS CURRENT LEAKAGE @ 2500 VOLTS AC.
 - 2.6 DEGREE OF PROTECTION: IP67 (MATED CONDITION)
 - 2.7 DEGREE OF POLLUTION: 3 PER UL840
 - 2.8 OVERVOLTAGE CATEGORY: III PER UL840
 - 2.9 MATING CYCLE DURABILITY: >500 CYCLES
 - 2.10 RoHS COMPLIANT

3. ALL DIMENSIONS ARE FOR REFERENCE USE ONLY.

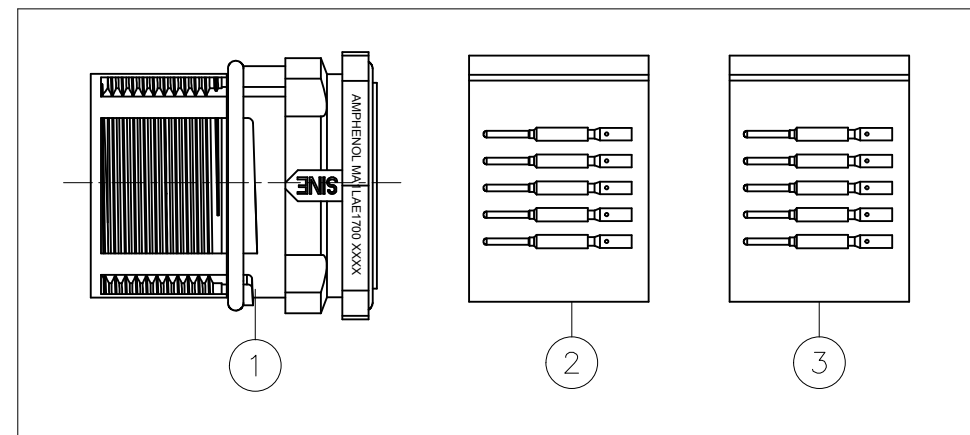

17	SC000146	CONTACT, PIN, Ø1.0mm ,Crimp 28~24AWG	3
17	SC000035	CONTACT, PIN, Ø1.0mm, Crimp 22~18AWG	2
1	MA1LAE1700	CONNECTOR	1
QUANTITY	PART NUMBER	DESCRIPTION	ITEM

MATERIALS LIST			
UNLESS OTHERWISE SPECIFIED		SIGNATURES	DATE
1) All dimensions are in metric(mm).		DRAWN: White	Oct.30,2017
2) Tolerances are as follows:		CHECKED: Tod	Oct.30,2017
1 PL DEC ±0.30 Fractions ±1/64		ENGINEER:	
2 PL DEC ±0.15 Angles ±1°		APPROVAL: Tommy	Oct.30,2017
3 PL DEC ±0.08		CUSTOMER:	
3) Note reference =		THIS DRAWING IS SUPPLIED FOR INFORMATION ONLY. DESIGN FEATURES, SPECIFICATIONS AND PERFORMANCE DATA SHOWN HEREON ARE THE PROPERTY OF THE AMPHENOL CORPORATION. NO RIGHTS OF REPRODUCTION ARE IMPLIED. ALL DIMENSIONS ARE SUBJECT TO NORMAL MANUFACTURING VARIATIONS.	
MATERIAL SPECIFICATIONS:		Sine Systems - www.amphenol-sine.com 44724 Morley Drive Clinton Township, MI 48036	
PROCESS SPECIFICATIONS:		KIT, M23A, RECEPTACLE, 17POS, E TYPE FLANGE MOUNT, PIN CONTACT	
NEXT ASSY:		SIZE: B	TYPE: C-
		SCALE: NONE	REVISION: A2
		DWG NO: MA1LAE1700-KIT	
		SHEET 1 OF 1	

TITLE: KIT,M23A,RECEPTACLE,17POS,E TYPE,FLANGE MOUNT,PIN CONTACT
 DWG NO: MA1LAE1700-KIT
 REV: A2
 SH: 1
 OF: 1