

# WISE-4012E

## 6-ch Input/Output IoT Wireless I/O Module for IoT Developers



### Introduction

The Advantech WISE IoT Developer Kit is a complete hardware & software solution to help users develop IoT applications and simulate their projects in the simplest way. The WISE IoT Developer Kit provides everything you need to get going: a WISE-4012E 6-ch universal input or output wireless Ethernet I/O module, and developer kit including: WebAccess 8.0 with open interfaces for intelligent application developer, extension board for simulating sensor status, a micro USB cable for power input, and a screwdriver for wiring. The WISE-4012E has an integrated Wi-Fi interface with AP mode and web configuration which can be accessed by mobile device directly. Data can be logged in the I/O module and then automatically pushed to the file-based cloud.

### Product Concept: Data A-P-P



Data Acquisition



Data Processing



Data Publishing

### Features

- 2.4 GHz IEEE 802.11b/g/n WLAN
- 2-ch 0 ~ 10V Input, 2-ch DI, and 2-ch Relay Output
- Includes WebAccess with demo project for developer
- Includes extension board for simulating sensor status
- Includes micro USB cable for power input
- Supports Modbus/TCP with RESTful web service
- Supports wireless client and server mode that can be accessed directly without AP or router
- Supports mobile device web configuration with HTML5 without the platform limitation
- Supports file-based cloud storage and local logging with time stamp



### IoT Developer Kit

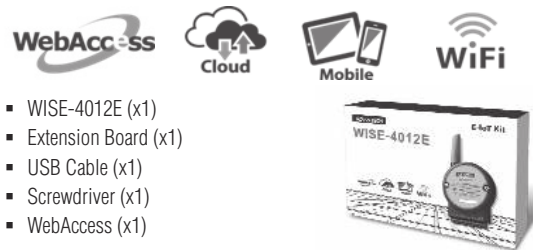

- WISE-4012E (x1)
- Extension Board (x1)
- USB Cable (x1)
- Screwdriver (x1)
- WebAccess (x1)

### Application Scenario 1

Connect to end devices

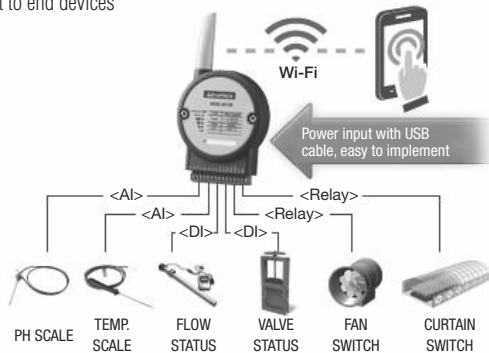

### Application Scenario 2

Connect to an extension board

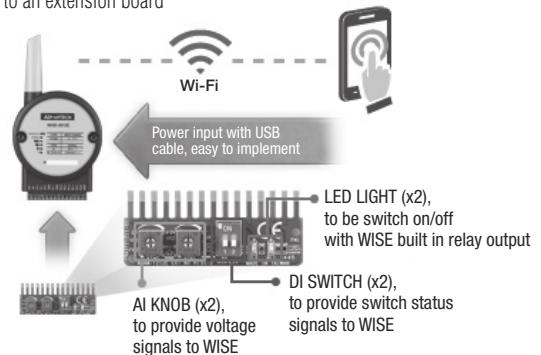

## Specifications

### Voltage Input

▪ Channel	2
▪ Resolution	12-bit
▪ Sampling Rate	10 Hz (Total)
▪ Accuracy	±0.1 V <sub>DC</sub>
▪ Input Type and Range	0 ~ 10 V
▪ Input Impedance	100 kΩ

### Digital Input

▪ Channels	2
▪ Logic level	Dry Contact 0: Open 1: Close to GND
▪ Supports 3 kHz Counter Input (32-bit + 1-bit overflow)	
▪ Keep/Discard Counter Value when Power-off	
▪ Supports 3 kHz Frequency Input	
▪ Supports Inverted DI Status	

### Relay Output

▪ Channels	2 (Form A)
▪ Contact Rating (Resistive Load)	120 V <sub>AC</sub> @ 0.5 A 30 V <sub>DC</sub> @ 1 A
▪ Isolation (b/w coil & contacts)	1,500 V <sub>rms</sub>
▪ Relay On Time	10 ms
▪ Relay Off Time	7 ms
▪ Insulation Resistance	1 GΩ min. @ 500 V <sub>DC</sub>
▪ Maximum Switching	60 operations/minute
▪ Supports Pulse Output	
▪ Supports High-to-Low and Low-to-High Delay Output	

### Environment

▪ Operating Temperature	-25 ~ 70°C (-13 ~ 158°F)
▪ Storage Temperature	-40 ~ 85°C (-40 ~ 185°F)
▪ Operating Humidity	20 ~ 95% RH (non-condensing)
▪ Storage Humidity	0 ~ 95% RH (non-condensing)

### General

▪ WLAN	IEEE 802.11b/g/n 2.4GHz
▪ Connectors	Plug-in screw terminal block (I/O)
▪ Watchdog Timer	System (1.6 second) and Communication (programmable)
▪ Certification	CE, FCC, R&TTE, NCC, SRR, RoHS, ANATEL
▪ Dimensions (W x H x D)	80 x 139 x 25 mm
▪ Enclosure	PC
▪ Power Input	Micro-B USB 5 V <sub>DC</sub>
▪ Power Consumption	1.5 W @ 5 V <sub>DC</sub>
▪ Supports User Defined Modbus Address	
▪ Supports Data Log Function	Up to 10,000 samples with time stamp
▪ Supported Protocols	Modbus/TCP, TCP/IP, UDP, DHCP, and HTTP
▪ Supports RESTful Web API in JSON format	
▪ Supports Web Server in HTML5 with JavaScript & CSS3	
▪ Supports System Configuration Backup and User Access Control	

## Ordering Information

▪ WISE-4012E-AE-WA	WISE-4012E IoT Developer Kit with WebAccess
--------------------	---

## Advantech WebAccess 8.0

### WebAccess Cloud Architecture

WebAccess is a 100% web based HMI and SCADA software with private cloud software architecture. WebAccess can provide large equipment vendors, SIs, and Enterprises access to and manipulation of centralized data to configure, change/update, or monitor their equipment, projects, and systems all over the world using a standard web browser. Also, all the engineering works, such as: database configuration, graphics drawing and system management and the troubleshooting can be operated remotely. This can significantly increase the efficiency of maintenance operations and reduce maintenance costs.

### Business Intelligence Dashboard

WebAccess 8.0 provides an HTML5 based Dashboard as the next generation of WebAccess HMI. System integrators can use Dashboard Editor to create the customized information page by using analysis charts and diagrams which are called widgets. Ample widgets have been included in the built-in widget library, such as trends, bars, alarm summary, maps... etc. After the dashboard screens have been created, end user can view the data by Dashboard Viewer in different platforms, like Explorer, Safari, Chrome, and Firefox for a seamless viewing experience across PCs, Macs, tablets and smartphones.

### Open Interfaces

WebAccess has three interfaces for different uses. First, WebAccess provides a Web Service interface for partners to integrate WebAccess data into APPs or application system. Second, a pluggable widget interface has been opened for programmer to develop their widget and run on WebAccess Dashboard. Last, WebAccess API, a DLL interface for programmer to access WebAccess platform and develop Windows applications. With these interfaces, WebAccess can act as an IoT platform for partners to develop IoT applications in various vertical markets.

### Google Maps and GPS Tracking Integration

WebAccess integrates real-time data on each geographical site with Google Maps and GPS location tracking. For remote monitoring, users can intuitively view the current energy consumption on each building, production rate on each field or traffic flow on the highway together with alarm status. By right-clicking on Google Maps or entering the coordinate of the target, users can create a marker for the target and associate the real-time data of three sites with a display label. Furthermore, this function also integrates with GPS modules to track the location of the marker in Google Maps and allows it to be used in vehicle systems.

### Ample Driver Support

WebAccess supports hundreds of devices. In addition to Advantech I/Os and controllers, WebAccess also supports all major PLCs, controllers and I/Os, like Allen Bradley, Siemens, LonWorks, Mitsubishi, Beckhoff, Yokogawa etc. WebAccess can easily integrate all devices in one SCADA. All of these device drivers are integrated into WebAccess and free of charge. For a complete list of WebAccess drivers, refer to [webaccess.advantech.com](http://webaccess.advantech.com).

### Distributed SCADA Architecture with Central Database Server

SCADA nodes run independent of any other node. Each SCADA node communicates to automation equipment using communication drivers supplied with Advantech WebAccess. The Project Node is a centralized database server of configuration data. A copy of the database and graphics of all SCADA nodes is kept on the Project Node. The historical data is also stored in the database in project node.

### Open Data Connectivity

Advantech WebAccess exchanges online data with 3rd party software in real-time by supporting OPC UA/DA, DDE, Modbus and BACnet Server/Client. It supports SQL, Oracle, MySQL, and MS Access for offline data sharing.

### Software Requirements

▪ Operating System	Windows XP (SCADA Node Only), Windows 7 SP1, Windows 8 Professional, Windows Server 2008 R2 or later
▪ Hardware	Intel Atom or Celeron. Dual Core processors or higher recommended 2GB RAM minimum, more recommended 30GB or more free disk space