

54AC240 • 54ACT240 Octal Buffer/Line Driver with TRI-STATE® Outputs

General Description

The 'AC/'ACT240 is an octal buffer and line driver designed to be employed as a memory address driver, clock driver and bus oriented transmitter or receiver which provides improved PC board density.

- Inverting TRI-STATE outputs drive bus lines or buffer memory address registers
- Outputs source/sink 24 mA
- 'ACT240 has TTL-compatible inputs
- Standard Microcircuit Drawing (SMD)
 - 'AC240: 5962-87550
 - 'ACT240: 5962-87759

Features

- I_{CC} and I_{OZ} reduced by 50%

Logic Symbol

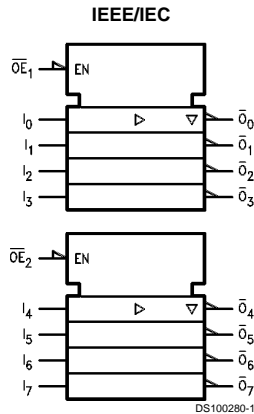

Pin Names	Description
$\overline{OE}_1, \overline{OE}_2$	TRI-STATE Output Enable Inputs
I_0-I_7	Inputs
$\overline{O}_0-\overline{O}_7$	Outputs

Connection Diagrams

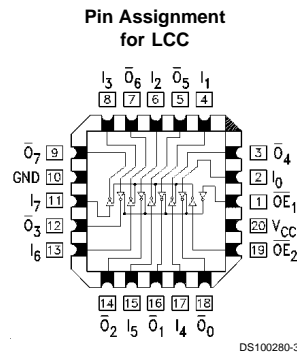
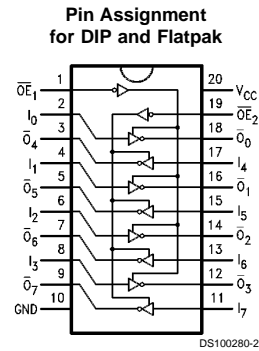

TRI-STATE® is a registered trademark of National Semiconductor Corporation.
FACT® is a registered trademark of Fairchild Semiconductor Corporation.

Truth Tables

Inputs		Outputs (Pins 12, 14, 16, 18)
\overline{OE}_1	I_n	
L	L	H
L	H	L
H	X	Z

Inputs		Outputs (Pins 3, 5, 7, 9)
\overline{OE}_2	I_n	
L	L	H
L	H	L
H	X	Z

H = HIGH Voltage Level
L = LOW Voltage Level
X = Immaterial
Z = High Impedance

Absolute Maximum Ratings (Note 1)

If Military/Aerospace specified devices are required, please contact the National Semiconductor Sales Office/Distributors for availability and specifications.

Supply Voltage (V_{CC})	-0.5V to +7.0V
DC Input Diode Current (I_{IK})	
$V_I = -0.5V$	-20 mA
$V_I = V_{CC} + 0.5V$	+20 mA
DC Input Voltage (V_I)	-0.5V to $V_{CC} + 0.5V$
DC Output Diode Current (I_{OK})	
$V_O = -0.5V$	-20 mA
$V_O = V_{CC} + 0.5V$	+20 mA
DC Output Voltage (V_O)	-0.5V to $V_{CC} + 0.5V$
DC Output Source or Sink Current (I_O)	±50 mA
DC V_{CC} or Ground Current per Output Pin (I_{CC} or I_{GND})	±50 mA
Storage Temperature (T_{STG})	-65°C to +150°C
Junction Temperature (T_J)	
CDIP	175°C

Recommended Operating Conditions

Supply Voltage (V_{CC})	
'AC	2.0V to 6.0V
'ACT	4.5V to 5.5V
Input Voltage (V_I)	0V to V_{CC}
Output Voltage (V_O)	0V to V_{CC}
Operating Temperature (T_A)	
54AC/ACT	-55°C to +125°C
Minimum Input Edge Rate ($\Delta V/\Delta t$)	
'AC Devices	
V_{IN} from 30% to 70% of V_{CC}	
V_{CC} @ 3.3V, 4.5V, 5.5V	125 mV/ns
Minimum Input Edge Rate ($\Delta V/\Delta t$)	
'ACT Devices	
V_{IN} from 0.8V to 2.0V	
V_{CC} @ 4.5V, 5.5V	125 mV/ns

Note 1: Absolute maximum ratings are those values beyond which damage to the device may occur. The databook specifications should be met, without exception, to ensure that the system design is reliable over its power supply, temperature, and output/input loading variables. National does not recommend operation of FACT® circuits outside databook specifications.

DC Characteristics for 'AC Family Devices

Symbol	Parameter	V_{CC} (V)	54AC	Units	Conditions	
			$T_A =$ -55°C to +125°C			
			Guaranteed Limits			
V_{IH}	Minimum High Level Input Voltage	3.0	2.1	V	$V_{OUT} = 0.1V$ or $V_{CC} - 0.1V$	
		4.5	3.15			
		5.5	3.85			
V_{IL}	Maximum Low Level Input Voltage	3.0	0.9	V	$V_{OUT} = 0.1V$ or $V_{CC} - 0.1V$	
		4.5	1.35			
		5.5	1.65			
V_{OH}	Minimum High Level Output Voltage	3.0	2.9	V	$I_{OUT} = -50 \mu A$	
		4.5	4.4			
		5.5	5.4			
			3.0	2.4	V	(Note 2) $V_{IN} = V_{IL}$ or V_{IH} $I_{OH} = -12 \text{ mA}$ $I_{OH} = -24 \text{ mA}$ $I_{OH} = -24 \text{ mA}$
			4.5	3.7		
			5.5	4.7		
V_{OL}	Maximum Low Level Output Voltage	3.0	0.1	V	$I_{OUT} = 50 \mu A$	
		4.5	0.1			
		5.5	0.1			
			3.0	0.50	V	(Note 2) $V_{IN} = V_{IL}$ or V_{IH} $I_{OL} = 12 \text{ mA}$ $I_{OL} = 24 \text{ mA}$ $I_{OL} = 24 \text{ mA}$
			4.5	0.50		
			5.5	0.50		
I_{IN}	Maximum Input Leakage Current	5.5	±1.0	μA	$V_I = V_{CC}, GND$	

DC Characteristics for 'AC Family Devices (Continued)

Symbol	Parameter	V _{CC} (V)	54AC	Units	Conditions
			T _A = -55°C to +125°C		
			Guaranteed Limits		
I _{OZ}	Maximum TRI-STATE Leakage Current	5.5	±5.0	µA	V _I (OE) = V _{IL} , V _{IH} V _I = V _{CC} , GND V _O = V _{CC} , GND
I _{OLD}	Minimum Dynamic	5.5	50	mA	V _{OLD} = 1.65V Max
I _{OHD}	Output Current (Note 3)	5.5	-50	mA	V _{OHD} = 3.85V Min
I _{CC}	Maximum Quiescent Supply Current	5.5	80.0	µA	V _{IN} = V _{CC} or GND

Note 2: All outputs loaded; thresholds on input associated with output under test.

Note 3: Maximum test duration 2.0 ms, one output loaded at a time.

Note 4: I_{IN} and I_{CC} @ 3.0V are guaranteed to be less than or equal to the respective limit @ 5.5V V_{CC}.

I_{CC} for 54AC @ 25°C is identical to 74AC @ 25°C.

DC Characteristics for 'ACT Family Devices

Symbol	Parameter	V _{CC} (V)	54ACT	Units	Conditions
			T _A = -55°C to +125°C		
			Guaranteed Limits		
V _{IH}	Minimum High Level Input Voltage	4.5	2.0	V	V _{OUT} = 0.1V or V _{CC} - 0.1V
		5.5	2.0		
V _{IL}	Maximum Low Level Input Voltage	4.5	0.8	V	V _{OUT} = 0.1V or V _{CC} - 0.1V
		5.5	0.8		
V _{OH}	Minimum High Level Output Voltage	4.5	4.4	V	I _{OUT} = -50 µA
		5.5	5.4		
		4.5	3.70	V	(Note 5) V _{IN} = V _{IL} or V _{IH} I _{OH} = -24 mA I _{OH} = -24 mA
		5.5	4.70		
V _{OL}	Maximum Low Level Output Voltage	4.5	0.1	V	I _{OUT} = 50 µA
		5.5	0.1		
		4.5	0.50	V	(Note 5) V _{IN} = V _{IL} or V _{IH} I _{OL} = 24 mA I _{OL} = 24 mA
		5.5	0.50		
I _{IN}	Maximum Input Leakage Current	5.5	±1.0	µA	V _I = V _{CC} , GND
I _{OZ}	Maximum TRI-STATE Leakage Current	5.5	±5.0	µA	V _I = V _{IL} , V _{IH} V _O = V _{CC} , GND
I _{CCT}	Maximum I _{CC} /Input	5.5	1.6	mA	V _I = V _{CC} - 2.1V
I _{OLD}	Minimum Dynamic	5.5	50	mA	V _{OLD} = 1.65V Max
I _{OHD}	Output Current (Note 6)	5.5	-50	mA	V _{OHD} = 3.85V Min
I _{CC}	Maximum Quiescent Supply Current	5.5	80.0	µA	V _{IN} = V _{CC} or GND

Note 5: All outputs loaded; thresholds on input associated with output under test.

Note 6: Maximum test duration 2.0 ms, one output loaded at a time.

Note 7: I_{CC} for 54ACT @ 25°C is identical to 74ACT @ 25°C.

AC Electrical Characteristics

Symbol	Parameter	V _{CC} (V) (Note 8)	54AC		Units
			T _A = -55°C to +125°C C _L = 50 pF		
			Min	Max	
t _{PLH}	Propagation Delay	3.3	1.0	11.0	ns
	Data to Output	5.0	1.0	8.5	
t _{PHL}	Propagation Delay	3.3	1.0	10.5	ns
	Data to Output	5.0	1.0	8.0	
t _{PZH}	Output Enable Time	3.3	1.0	11.5	ns
		5.0	1.0	9.0	
t _{PZL}	Output Enable Time	3.3	1.0	13.0	ns
		5.0	1.0	10.5	
t _{PHZ}	Output Disable Time	3.3	1.0	12.5	ns
		5.0	1.0	10.5	
t _{PLZ}	Output Disable Time	3.3	1.0	13.5	ns
		5.0	1.0	11.0	

Note 8: Voltage Range 3.3 is 3.3V ±0.3V
Voltage Range 5.0 is 5.0V ±0.5V

AC Electrical Characteristics

Symbol	Parameter	V _{CC} (V) (Note 9)	54ACT		Units
			T _A = -55°C to +125°C C _L = 50 pF		
			Min	Max	
t _{PLH}	Propagation Delay	5.0	1.0	9.5	ns
	Data to Output				
t _{PHL}	Propagation Delay	5.0	1.0	9.0	ns
	Data to Output				
t _{PZH}	Output Enable Time	5.0	1.0	10.0	ns
t _{PZL}	Output Enable Time	5.0	1.0	11.5	ns
t _{PHZ}	Output Disable Time	5.0	1.0	11.0	ns
t _{PLZ}	Output Disable Time	5.0	1.0	11.5	ns

Note 9: Voltage Range 5.0 is 5.0V ±0.5V

Capacitance

Symbol	Parameter	Typ	Units	Conditions
C _{IN}	Input Capacitance	4.5	pF	V _{CC} = OPEN
C _{PD}	Power Dissipation Capacitance	45.0	pF	V _{CC} = 5.0V



Physical Dimensions inches (millimeters) unless otherwise noted

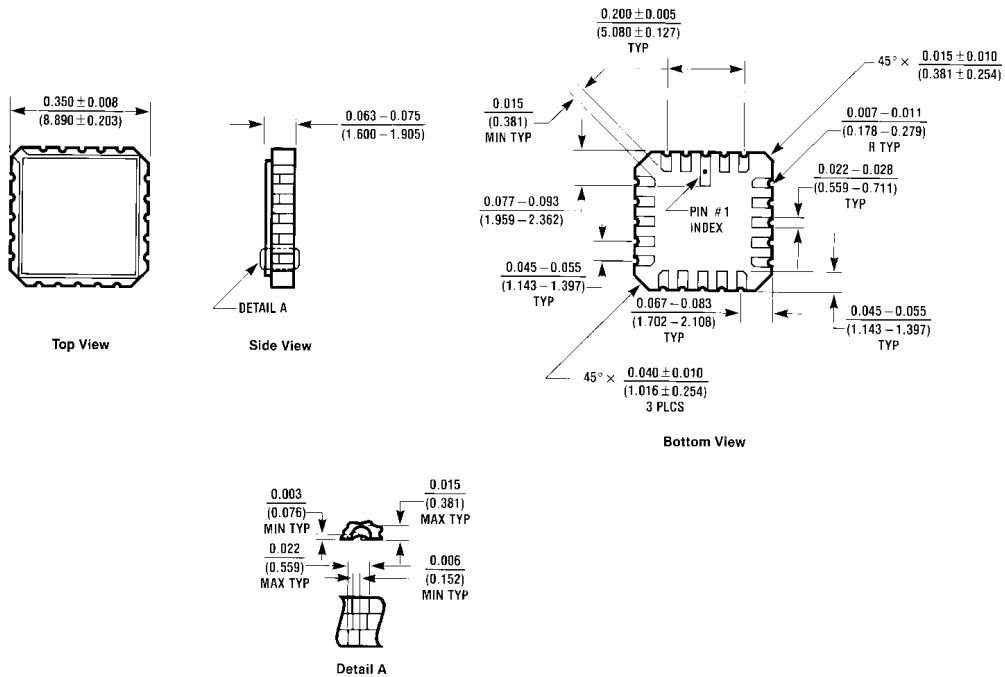

L20A (REV D)

**20 Terminal Ceramic Leadless Chip Carrier (L)
 NS Package Number E20A**

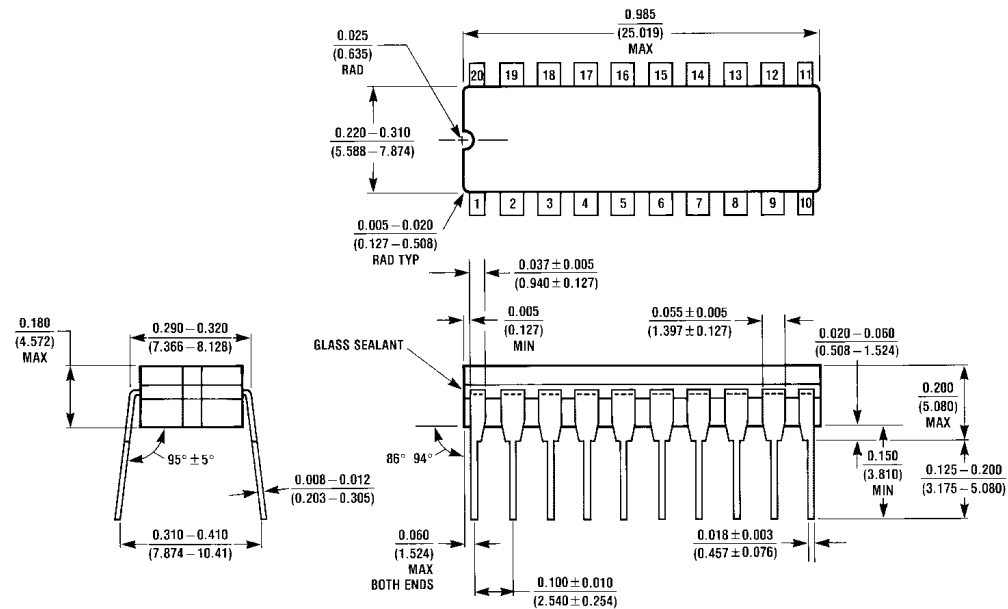

J20A (REV M)

**20 Lead Ceramic Dual-In-Line Package (D)
 NS Package Number J20A**

Physical Dimensions inches (millimeters) unless otherwise noted (Continued)

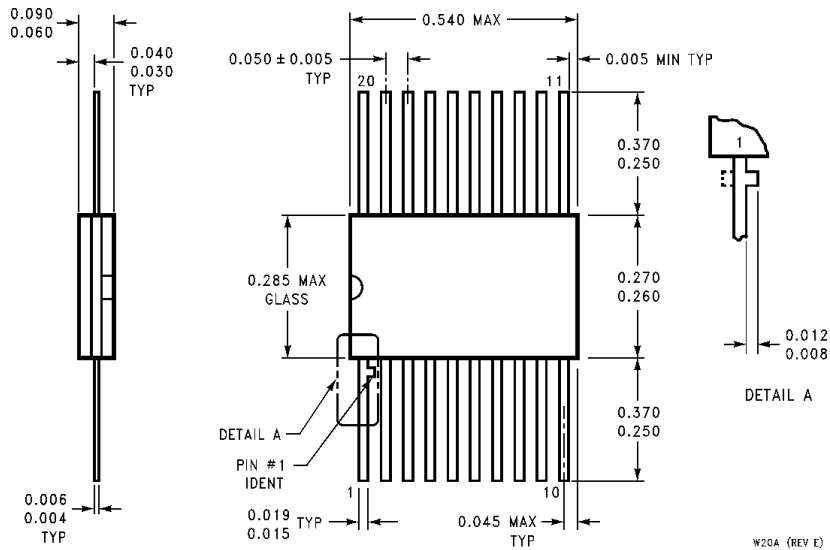

**20 Lead Ceramic Flatpak (F)
NS Package Number W20A**

LIFE SUPPORT POLICY

NATIONAL'S PRODUCTS ARE NOT AUTHORIZED FOR USE AS CRITICAL COMPONENTS IN LIFE SUPPORT DEVICES OR SYSTEMS WITHOUT THE EXPRESS WRITTEN APPROVAL OF THE PRESIDENT OF NATIONAL SEMICONDUCTOR CORPORATION. As used herein:

1. Life support devices or systems are devices or systems which, (a) are intended for surgical implant into the body, or (b) support or sustain life, and whose failure to perform when properly used in accordance with instructions for use provided in the labeling, can be reasonably expected to result in a significant injury to the user.
2. A critical component in any component of a life support device or system whose failure to perform can be reasonably expected to cause the failure of the life support device or system, or to affect its safety or effectiveness.



National Semiconductor Corporation
Americas
Tel: 1-800-272-9959
Fax: 1-800-737-7018
Email: support@nsc.com

National Semiconductor Europe
Fax: +49 (0) 1 80-530 85 86
Email: europe.support@nsc.com
Deutsch Tel: +49 (0) 1 80-530 85 85
English Tel: +49 (0) 1 80-532 78 32
Français Tel: +49 (0) 1 80-532 93 58
Italiano Tel: +49 (0) 1 80-534 16 80

National Semiconductor Asia Pacific Customer Response Group
Tel: 65-2544466
Fax: 65-2504466
Email: sea.support@nsc.com

National Semiconductor Japan Ltd.
Tel: 81-3-5620-6175
Fax: 81-3-5620-6179

www.national.com

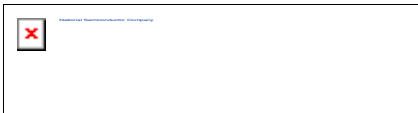

54ACT240 Octal Buffer/Line Driver with TRI-STATE Outputs

Contents

- [General Description](#)
- [Features](#)
- [Datasheet](#)
- [Package Availability, Models, Samples & Pricing](#)



General Description

The 'AC/ACT240 is an octal buffer and line driver designed to be employed as a memory address driver, clock driver and bus oriented transmitter or receiver which provides improved PC board density.

Features



- I_{CC} and I_{OZ} reduced by 50%
- Inverting TRI-STATE outputs drive bus lines or buffer memory address registers
- Outputs source/sink 24 mA
- 'ACT240 has TTL-compatible inputs
- Standard Microcircuit Drawing (SMD) -'AC240: 5962-87550 -'ACT240: 5962-87759

Datasheet

Title	Size (in Kbytes)	Date	 View Online	 Download	 Receive via Email
54AC240 54ACT240 Octal Buffer/Line Driver with TRI-STATE Outputs	138 Kbytes	14-Aug-98	View Online	Download	Receive via Email

Please use [Adobe Acrobat](#) to view PDF file(s).
If you have trouble printing, see [Printing Problems](#).

Package Availability, Models, Samples & Pricing

Part Number	Package		Status	Models		Samples & Electronic Orders	Budgetary Pricing		Std Pack Size	Package Marking
	Type	# pins		SPICE	IBIS		Quantity	\$US each		
5962-8775901M2A	LCC	20	Full production	N/A	N/A		50+	\$7.0000	tube of 50	[logo]çZçSç4çA 54ACT240 LMQB /QçM\$E 5962- 8775901M2A
54ACT240DM	Cerdip	20	Lifetime buy	N/A	N/A	.	50+	\$8.0000	tube of 20	[logo]çZçSç4çA\$E 54ACT240DM
5962-8775901MRA	Cerdip	20	Full production	N/A	N/A		50+	\$6.0000	tube of 20	[logo]çZçSç4çA\$E 54ACT240DMQB /QçM 5962-8775901MRA
5962-8775901MSA	Cerpack	20	Full production	N/A	N/A		50+	\$6.7500	tube of 19	[logo]çZçSç4çA\$E 54ACT240FMQB QçM 5962- 8775901MSA
5962R8775901BRA	Cerdip	20	Full production	N/A	N/A	.	50+	\$90.0000	tube of 20	[logo]çZçSç4çA\$E 5962R8775901BRA 27014 Q
5962R8775901BSA	Cerpack	20	Full production	N/A	N/A	.	50+	\$92.0000	tube of 19	[logo]çZçSç4çA\$E 27014 Q 5962 R8775901BSA

5962-8775901B2A	LCC	20	Full production	N/A	N/A	.	50+	\$9.0000	tube of 50	[logo] 5962-8775901B2A 27014 QS çZçSç4çA\$E
5962R8775901B2A	LCC	20	Full production	N/A	N/A	.	50+	\$70.0000	tube of 50	[logo] 5962R8775901B2A 27014 QS çZçSç4çA\$E
5962-8775901BRA	Cerdip	20	Full production	N/A	N/A		50+	\$8.0000	tube of 20	[logo] çZçSç4çA\$E 5962-8775901BRA 27014 QS
5962R8775901S2A	LCC	20	Full production	N/A	N/A	.	50+	\$138.0000	tube of 50	[logo]çZçSç4çA 27014 Q \$E 5962R 8775901S2A
5962R8775901SRA	Cerdip	20	Full production	N/A	N/A	.	50+	\$138.0000	tube of 20	[logo]çZçSç4çA\$E 5962R8775901SRA 27014 Q
5962R8775901SSA	Cerpack	20	Full production	N/A	N/A	.	50+	\$170.0000	tube of 19	[logo]çZçSç4çA\$E 5962R8775901SSA 27014 Q

[Information as of 1-Sep-2000]

Quick Search

[Parametric Search](#)

[System Diagrams](#)

[Product Tree](#)

[Home](#)

[About Languages](#) . [About the Site](#) . [About "Cookies"](#)

National is [QS 9000 Certified](#) . [Privacy/Security](#)

[Copyright](#) © National Semiconductor Corporation

[Preferences](#) . [Feedback](#)