

## PQ1CG21H2FZ PQ1CG21H2RZ

## Chopper Regulator

### TO-220 Type Chopper Regulator

#### General Description

Sharp's chopper regulator **PQ1CG21H2FZ/PQ1CG21H2RZ** of TO-220 package uses PWM method. It is suitable for the applications of large voltage difference between input and output and applications of negative power supply thank to its low heat loss.

#### Features

- (1) Maximum switching current: 1.5 A
- (2) Built-in ON/OFF control function
- (3) Built-in soft start function to suppress overshoot of output voltage in power on sequence or ON/OFF control sequence.
- (4) Built-in oscillation circuit  
(Oscillation frequency : TYP. 100 kHz)
- (5) Built-in overheat/overcurrent protection function
- (6) TO-220 package
- (7) Variable output voltage  
(Output variable range : 1.26 to 35 V/-1.26 to -30 V)  
[Possible to choose step-down output/inverting output according to external connection circuit]
- (8) **PQ1CG21H2FZ** : Zigzag forming  
**PQ1CG21H2RZ** : Self-stand forming

#### Applications

- (1) Switching power supplies
- (2) Facsimiles, printers and other OA equipment
- (3) Color TVs and video CDs
- (4) Personal computers and amusement equipment

#### Outline Dimensions

(Unit: mm)

PQ1CG21H2FZ

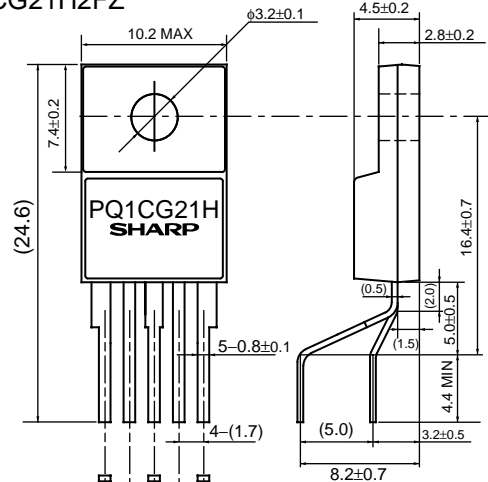

The dimension in ( ) indicates the reference dimensions.

#### Terminal No.

- ①  $V_{IN}$
- ②  $V_{OUT}$
- ③ COM
- ④ Oadj
- ⑤ ON/OFF

PQ1CG21H2RZ

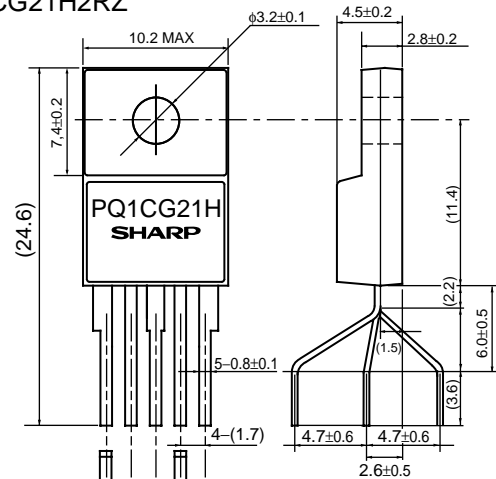

The dimension in ( ) indicates the reference dimensions.

#### Terminal No.

- ①  $V_{IN}$
- ②  $V_{OUT}$
- ③ COM
- ④ Oadj
- ⑤ ON/OFF

(Notice) • In the absence of confirmation by device specification sheets, SHARP takes no responsibility for any defects that may occur in equipment using any SHARP devices shown in catalogs, data books, etc. Contact SHARP in order to obtain the latest device specification sheets before using any SHARP device.

• Specifications are subject to change without notice for improvement.

(Internet) • Data for Sharp's optoelectronic/power devices is provided on internet. ( Address <http://www.sharp.co.jp/ecg/>)

## PQ1CG21H2FZ PQ1CG21H2RZ

## Chopper Regulator

### Absolute Maximum Ratings

(Ta=25°C)

Parameter	Symbol	Rating	Unit
*1 Input voltage	V <sub>IN</sub>	40	V
Output adjustment terminal voltage	V <sub>adj</sub>	7	V
Dropout voltage	V <sub>I-O</sub>	41	V
*2 Output-COM voltage	V <sub>out</sub>	-1	V
*3 ON/OFF control voltage	V <sub>c</sub>	-0.3 to 40	V
Switching current	I <sub>sw</sub>	1.5	A
*4 Power dissipation	P <sub>d1</sub>	1.4	W
	P <sub>d2</sub>	14	W
*5 Junction temperature	T <sub>j</sub>	150	°C
Operating temperature	T <sub>opr</sub>	-20 to +80	°C
Storage temperature	T <sub>stg</sub>	-40 to +150	°C
Soldering temperature	T <sub>sol</sub>	260(For 10s)	°C

\*1 Voltage between V and COM

\*2 Voltage between Vout and COM

\*3 Voltage between ON/OFF and COM

\*4 P: No heat sink P: With infinite heat sink.

\*5 Overheat protector may operate for Tj=125 to 150°C.

### Electrical Characteristics

(V<sub>in</sub>=12 V, I<sub>o</sub>=0.5 A, Terminal No. 5 open and Ta=25°C unless otherwise specified)

Parameter	Symbol	Conditions	MIN.	TYP.	MAX.	Unit
Output saturation voltage	V <sub>sat</sub>	I <sub>sw</sub> =1A	-	1.0	1.5	V
Reference voltage	V <sub>ref</sub>	-	1.235	1.26	1.285	V
Reference voltage temperature fluctuation	ΔV <sub>ref</sub>	T <sub>j</sub> =0 to 125°C	-	±0.5	-	%
Load regulation	R <sub>egL</sub>	I <sub>o</sub> =0.2 to 1A	-	0.2	1.5	%
Line regulation	R <sub>egI</sub>	V <sub>in</sub> =8 to 35V	-	0.5	2.5	%
Efficiency	η	I <sub>o</sub> =1A	-	84	-	%
Oscillation frequency	f <sub>o</sub>	-	80	100	120	kHz
Oscillation frequency temperature fluctuation	Δf <sub>o</sub>	T <sub>j</sub> =0 to 125°C	-	±2	-	%
Overcurrent detection level	I <sub>L</sub>	-	1.55	2.0	2.6	A
Charge current	I <sub>CHG</sub>	Terminals 2/4 are open, Terminal 5	-	-10	-	∞A
Input threshold voltage	V <sub>THL</sub>	Duty=0% Terminal 4 = 0 V, Terminal 5	-	1.3	-	V
	V <sub>THH</sub>	Duty=100%, Terminal 4 is open, Terminal 5	-	2.3	-	V
ON threshold voltage	V <sub>THON</sub>	Terminal 4 = 0 V, Terminal 5	0.7	0.8	0.9	V
Standby current	I <sub>SD</sub>	V <sub>in</sub> =40V, Terminal 5 = 0 V=0V	-	140	400	∞A
Output OFF-state consumption current	I <sub>QS</sub>	V <sub>in</sub> =40V, Terminal 5 = 0 V=0.9V	-	8	12	mA

Step-down output circuit diagram  
PQ1CG21H2FZ/PQ1CG21H2RZ

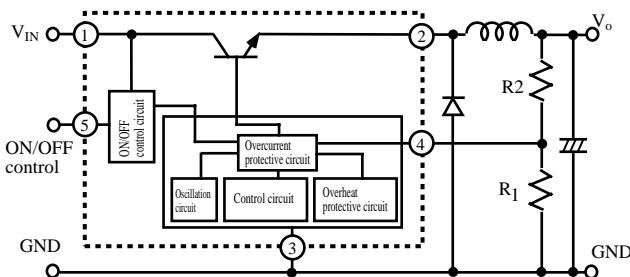

$$V_o = V_{ref} \times (1 + R_2/R_1) \quad (V_{ref} = 1.26V)$$

$$V_o = 1.26V \sim 35V$$

Here, the upper limit is restricted by V<sub>in</sub>-V<sub>sat</sub> value.

Inverting output circuit diagram  
PQ1CG21H2FZ/PQ1CG21H2RZ

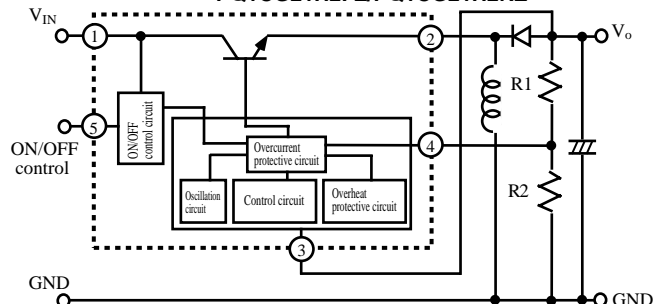

$$V_o = -V_{ref} \times (1 + R_2/R_1) \quad (V_{ref} = 1.26V)$$

$$V_o = -1.26V \sim -30V$$

Here, the upper limit of the absolute value is restricted by 40V-V<sub>i</sub>.

### NOTICE

- The circuit application examples in this publication are provided to explain representative applications of SHARP devices and are not intended to guarantee any circuit design or license any intellectual property rights. SHARP takes no responsibility for any problems related to any intellectual property right of a third party resulting from the use of SHARP's devices.
- Contact SHARP in order to obtain the latest device specification sheets before using any SHARP device. SHARP reserves the right to make changes in the specifications, characteristics, data, materials, structure, and other contents described herein at any time without notice in order to improve design or reliability. Manufacturing locations are also subject to change without notice.
- Observe the following points when using any devices in this publication. SHARP takes no responsibility for damage caused by improper use of the devices which does not meet the conditions and absolute maximum ratings to be used specified in the relevant specification sheet nor meet the following conditions:
  - (i) The devices in this publication are designed for use in general electronic equipment designs such as:
    - Personal computers
    - Office automation equipment
    - Telecommunication equipment [terminal]
    - Test and measurement equipment
    - Industrial control
    - Audio visual equipment
    - Consumer electronics
  - (ii) Measures such as fail-safe function and redundant design should be taken to ensure reliability and safety when SHARP devices are used for or in connection with equipment that requires higher reliability such as:
    - Transportation control and safety equipment (i.e., aircraft, trains, automobiles, etc.)
    - Traffic signals
    - Gas leakage sensor breakers
    - Alarm equipment
    - Various safety devices, etc.
  - (iii) SHARP devices shall not be used for or in connection with equipment that requires an extremely high level of reliability and safety such as:
    - Space applications
    - Telecommunication equipment [trunk lines]
    - Nuclear power control equipment
    - Medical and other life support equipment (e.g., scuba).
- Contact a SHARP representative in advance when intending to use SHARP devices for any "specific" applications other than those recommended by SHARP or when it is unclear which category mentioned above controls the intended use.
- If the SHARP devices listed in this publication fall within the scope of strategic products described in the Foreign Exchange and Foreign Trade Control Law of Japan, it is necessary to obtain approval to export such SHARP devices.
- This publication is the proprietary product of SHARP and is copyrighted, with all rights reserved. Under the copyright laws, no part of this publication may be reproduced or transmitted in any form or by any means, electronic or mechanical, for any purpose, in whole or in part, without the express written permission of SHARP. Express written permission is also required before any use of this publication may be made by a third party.
- Contact and consult with a SHARP representative if there are any questions about the contents of this publication.