



DM74ALS257, DM74ALS258 3-STATE Quad 1-of-2-Line Data Selector/Multiplexer

Features

- Switching specifications at 50pF
- Switching specifications guaranteed over full temperature and V_{CC} range
- Advanced oxide-isolated, ion-implanted Schottky TTL process
- Functionally and pin for pin compatible with Schottky and low power Schottky TTL counterpart
- Improved AC performance over Schottky and low power Schottky counterparts
- 3-STATE buffer-type outputs drive bus lines directly
- Expand any data input point
- Multiplex dual data buses
- General four functions of two variables (one variable is common)
- Source programmable counters

General Description

These data selectors/multiplexers contain inverters and drivers to supply full on-chip data selection to the four 3-STATE outputs that can interface directly with data lines of bus-organized systems. A 4-bit word selected from one of two sources is routed to the four outputs. The DM74ALS257 presents true data whereas the DM74ALS258 presents inverted data to minimize propagation delay time.

This 3-STATE output feature means that n-bit (paralleled) data selectors with up to 258 sources can be implemented for data buses. It also permits the use of standard TTL registers for data retention throughout the system.

Ordering Information

Order Number	Package Number	Package Description
DM74ALS257M	M16A	16-Lead Small Outline Integrated Circuit (SOIC), JEDEC MS-012, 0.150" Narrow
DM74ALS257SJ	M16D	16-Lead Small Outline Package (SOP), EIAJ TYPE II, 5.3mm Wide
DM74ALS258M	M16A	16-Lead Small Outline Integrated Circuit (SOIC), JEDEC MS-012, 0.150" Narrow

Devices also available in Tape and Reel. Specify by appending the suffix letter "X" to the ordering number.

Connection Diagram

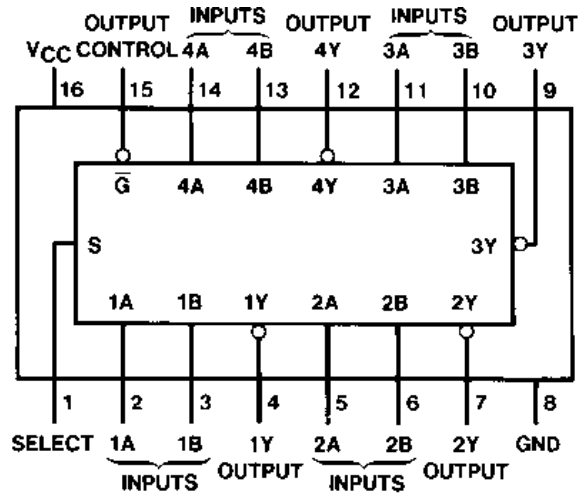

Function Table

Inputs				Output Y	
Output Control	Select	A	B	DM74ALS257	DM74ALS258
H	X	X	X	Z	Z
L	L	L	X	L	H
L	L	H	X	H	L
L	H	X	L	L	H
L	H	X	H	H	L

H = HIGH Level
 L = LOW Level
 X = Don't Care
 Z = High Impedance (OFF)

Logic Diagrams

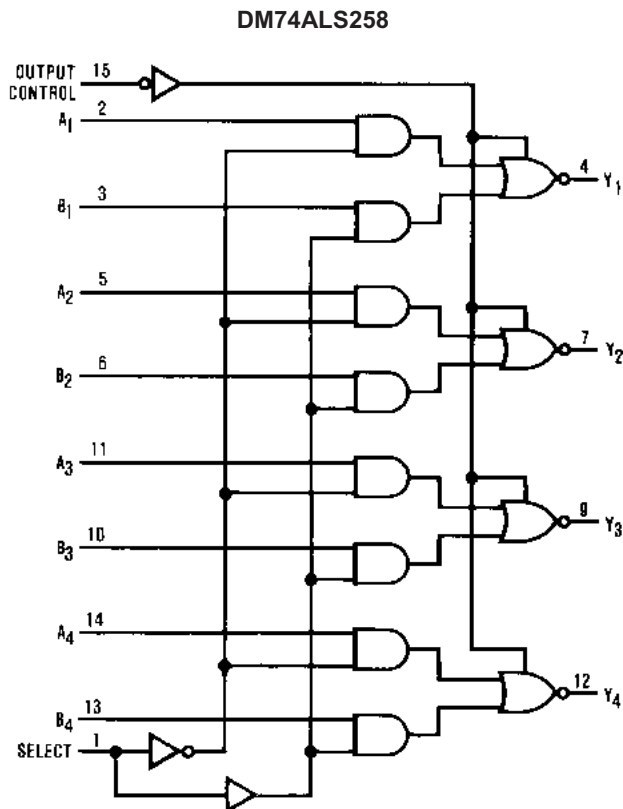
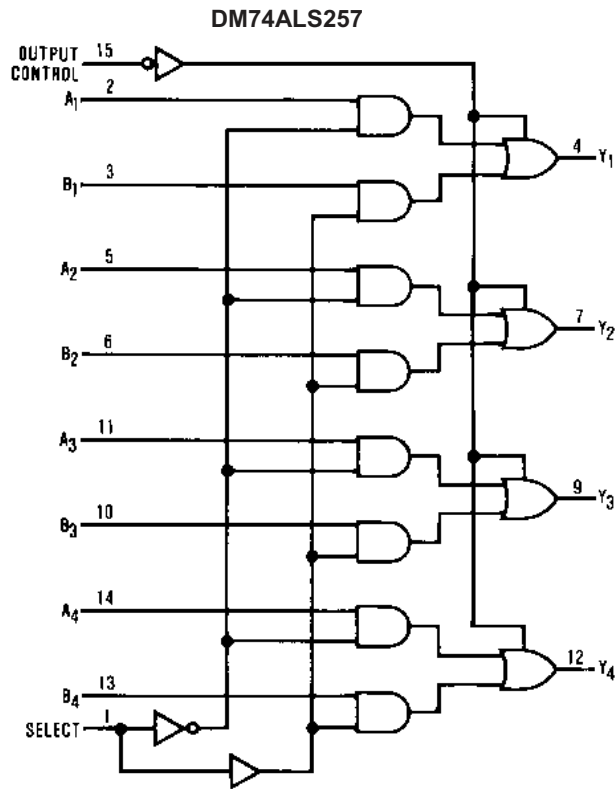

Absolute Maximum Ratings

Stresses exceeding the absolute maximum ratings may damage the device. The device may not function or be operable above the recommended operating conditions and stressing the parts to these levels is not recommended. In addition, extended exposure to stresses above the recommended operating conditions may affect device reliability. The absolute maximum ratings are stress ratings only.

Symbol	Parameter	Rating
V_{CC}	Supply Voltage	7V
V_I	Input Voltage	7V
	Voltage Applied to Disabled Output	5.5V
T_A	Operating Free Air Temperature Range	0°C to +70°C
T_{STG}	Storage Temperature Range	-65°C to +150°C
θ_{JA}	Typical Thermal Resistance	102.0°C/W

Recommended Operating Conditions

The Recommended Operating Conditions table defines the conditions for actual device operation. Recommended operating conditions are specified to ensure optimal performance to the datasheet specifications. Fairchild does not recommend exceeding them or designing to absolute maximum ratings.

Symbol	Parameter	Min.	Nom.	Max.	Units
V_{CC}	Supply Voltage	4.5	5	5.5	V
V_{IH}	HIGH Level Input Voltage	2			V
V_{IL}	LOW Level Input Voltage			0.8	V
I_{OH}	HIGH Level Output Current			-2.6	mA
I_{OL}	LOW Level Output Current			24	mA
T_A	Free Air Operating Temperature	0		70	°C

Electrical Characteristics

Over recommended operating free air temperature range. All typical values are measured at $V_{CC} = 5V$, $T_A = 25^\circ C$.

Symbol	Parameter		Conditions	Min.	Typ.	Max.	Units		
V_{IK}	Input Clamp Voltage		$V_{CC} = 4.5V$, $I_I = -18mA$			-1.5	V		
V_{OH}	HIGH Level Output Voltage		$V_{CC} = 4.5V$	$I_{OH} = -2.6mA$	2.4	3.3	V		
				$I_{OH} = -0.4mA$	$V_{CC} - 2$				
V_{OL}	LOW Level Output Voltage		$V_{CC} = 4.5V$	$I_{OL} = 12mA$		0.25	0.4	V	
				$I_{OL} = 24mA$		0.35	0.5		
I_I	Input Current at Maximum Input Voltage		$V_{CC} = 5.5V$, $V_{IH} = 7V$			0.1	mA		
I_{IH}	HIGH Level Input Current		$V_{CC} = 5.5V$, $V_{IH} = 2.7V$			20	μA		
I_{IL}	LOW Level Input Current		$V_{CC} = 5.5V$, $V_{IL} = 0.4V$			-0.1	mA		
I_O	Output Drive Current		$V_{CC} = 5.5V$, $V_O = 2.25V$	-30		-112	mA		
I_{OZH}	OFF-State Output Current, HIGH Level Voltage Applied		$V_{CC} = 5.5V$, $V_O = 2.7V$			20	μA		
I_{OZL}	OFF-State Output Current, LOW Level Voltage Applied		$V_{CC} = 5.5V$, $V_O = 0.4V$			-20	μA		
I_{CCH}	Supply Current	DM74ALS257	$V_{CC} = 5.5V$, Outputs OPEN	Outputs HIGH		3	6	mA	
		DM74ALS258				2.5	4		
I_{CCL}	Supply Current	DM74ALS257		$V_{CC} = 5.5V$, Outputs OPEN	Outputs LOW		8	12	mA
		DM74ALS258					7	11	
I_{CCZ}	Supply Current	DM74ALS257	$V_{CC} = 5.5V$, Outputs OPEN		Outputs Disabled		9	14	mA
		DM74ALS258					8	13	

Switching Characteristics DM74ALS257

Over recommended operating free air temperature range.

Symbol	Parameter	Conditions	From	To	Min.	Max.	Units
t_{PLH}	Propagation Delay Time, LOW-to-HIGH Level Output	$V_{CC} = 4.5V$ to $5.5V$, $C_L = 50pF$, $R_L = 500\Omega$	Data	Any Y	2	10	ns
t_{PHL}	Propagation Delay Time, HIGH-to-LOW Level Output		Data	Any Y	2	12	ns
t_{PLH}	Propagation Delay Time, LOW-to-HIGH Level Output		Select	Any Y	4	18	ns
t_{PHL}	Propagation Delay Time, HIGH-to-LOW Level Output		Select	Any Y	5	22	ns
t_{ZH}	Output Enable Time to HIGH Level		Output Control	Any Y	4	16	ns
t_{ZL}	Output Enable Time to LOW Level		Output Control	Any Y	5	18	ns
t_{HZ}	Output Disable Time from HIGH Level		Output Control	Any Y	2	10	ns
t_{LZ}	Output Disable Time from LOW Level		Output Control	Any Y	3	15	ns

Switching Characteristics DM74ALS258

Over recommended operating free air temperature range.

Symbol	Parameter	Conditions	From	To	Min.	Max.	Units
t_{PLH}	Propagation Delay Time, LOW-to-HIGH Level Output	$V_{CC} = 4.5V$ to $5.5V$, $C_L = 50pF$, $R_L = 500\Omega$	Data	Any Y	2	8	ns
t_{PHL}	Propagation Delay Time, HIGH-to-LOW Level Output		Data	Any Y	2	7	ns
t_{PLH}	Propagation Delay Time, LOW-to-HIGH Level Output		Select	Any Y	3	20	ns
t_{PHL}	Propagation Delay Time, HIGH-to-LOW Level Output		Select	Any Y	5	25	ns
t_{ZH}	Output Enable Time to HIGH Level		Output Control	Any Y	5	18	ns
t_{ZL}	Output Enable Time to LOW Level		Output Control	Any Y	5	18	ns
t_{HZ}	Output Disable Time from HIGH Level		Output Control	Any Y	2	10	ns
t_{LZ}	Output Disable Time from LOW Level		Output Control	Any Y	3	18	ns

Physical Dimensions

Dimensions are in millimeters unless otherwise noted.

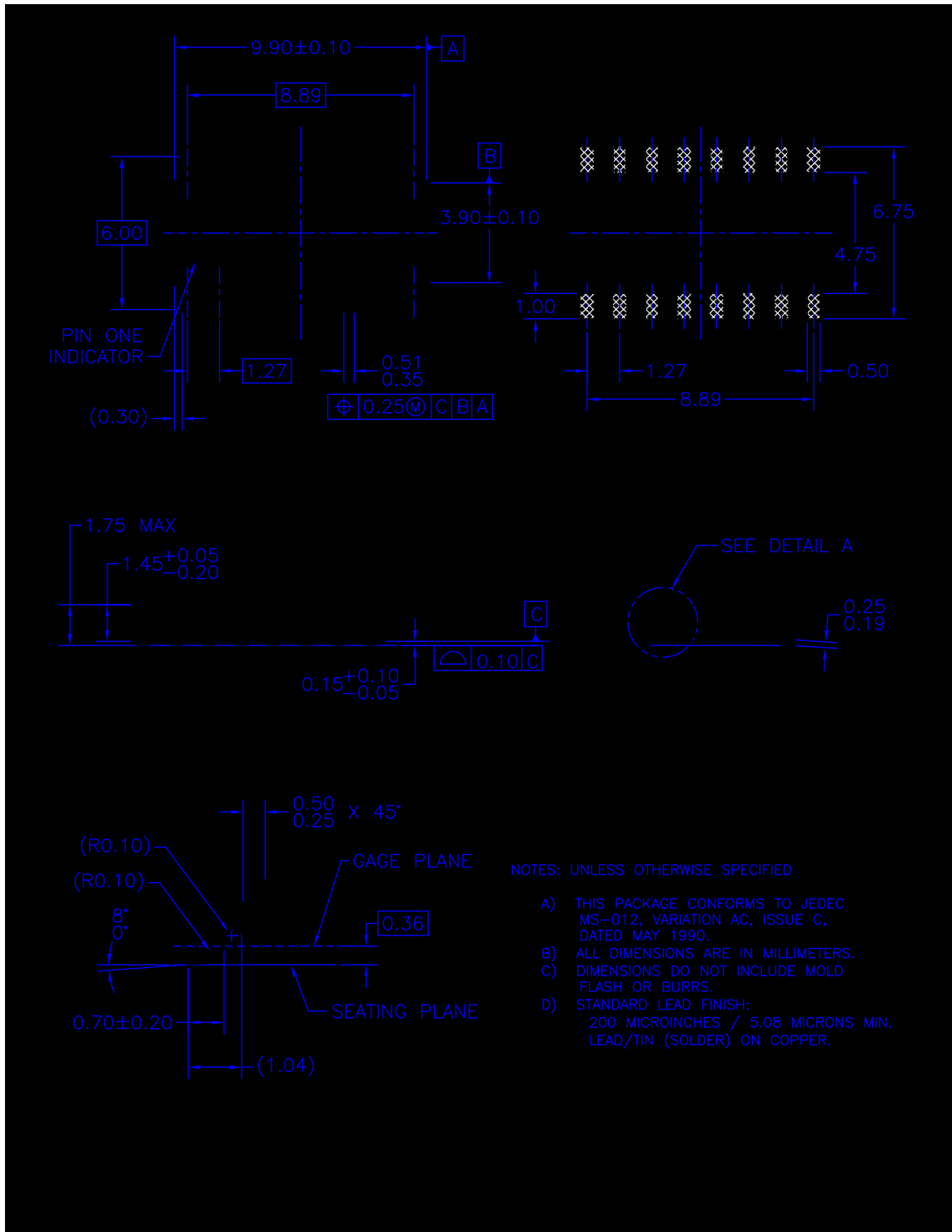

Figure 1. 16-Lead Small Outline Integrated Circuit (SOIC), JEDEC MS-012, 0.150" Narrow Package Number M16A

Physical Dimensions (Continued)

Dimensions are in millimeters unless otherwise noted.



**Figure 2. 16-Lead Small Outline Package (SOP), EIAJ TYPE II, 5.3mm Wide
Package Number M16D**

