

CAGE DETAILS

(APPLIES TO ALL CAGES IN THIS DRAWING)

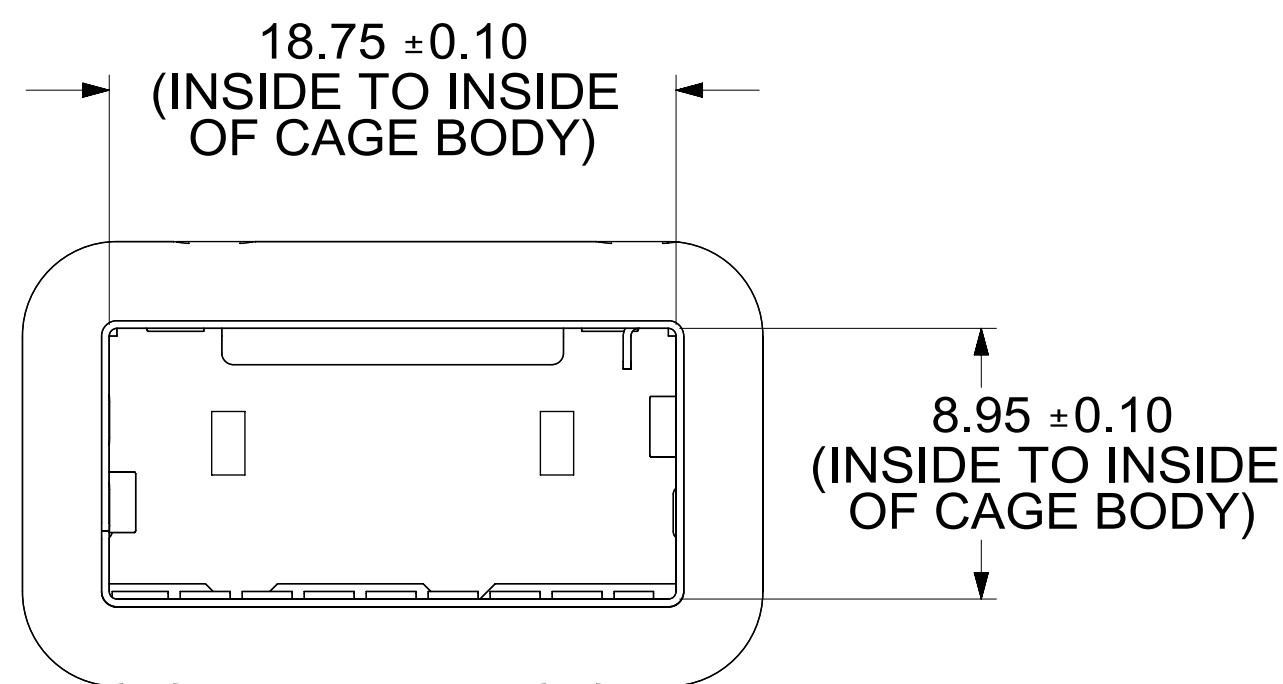

NOTE:
INTERNAL SPRING FINGERS
REMOVED FROM THIS VIEW FOR CLARITY.

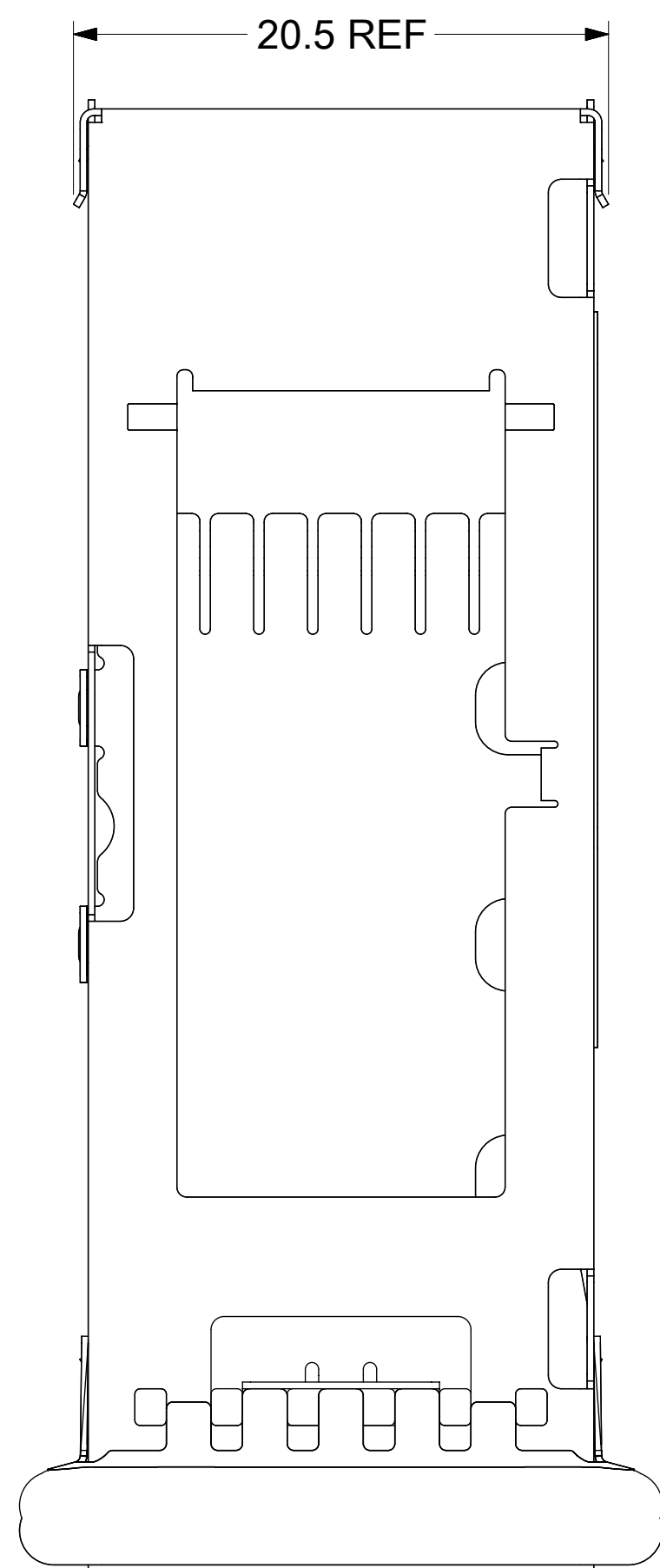
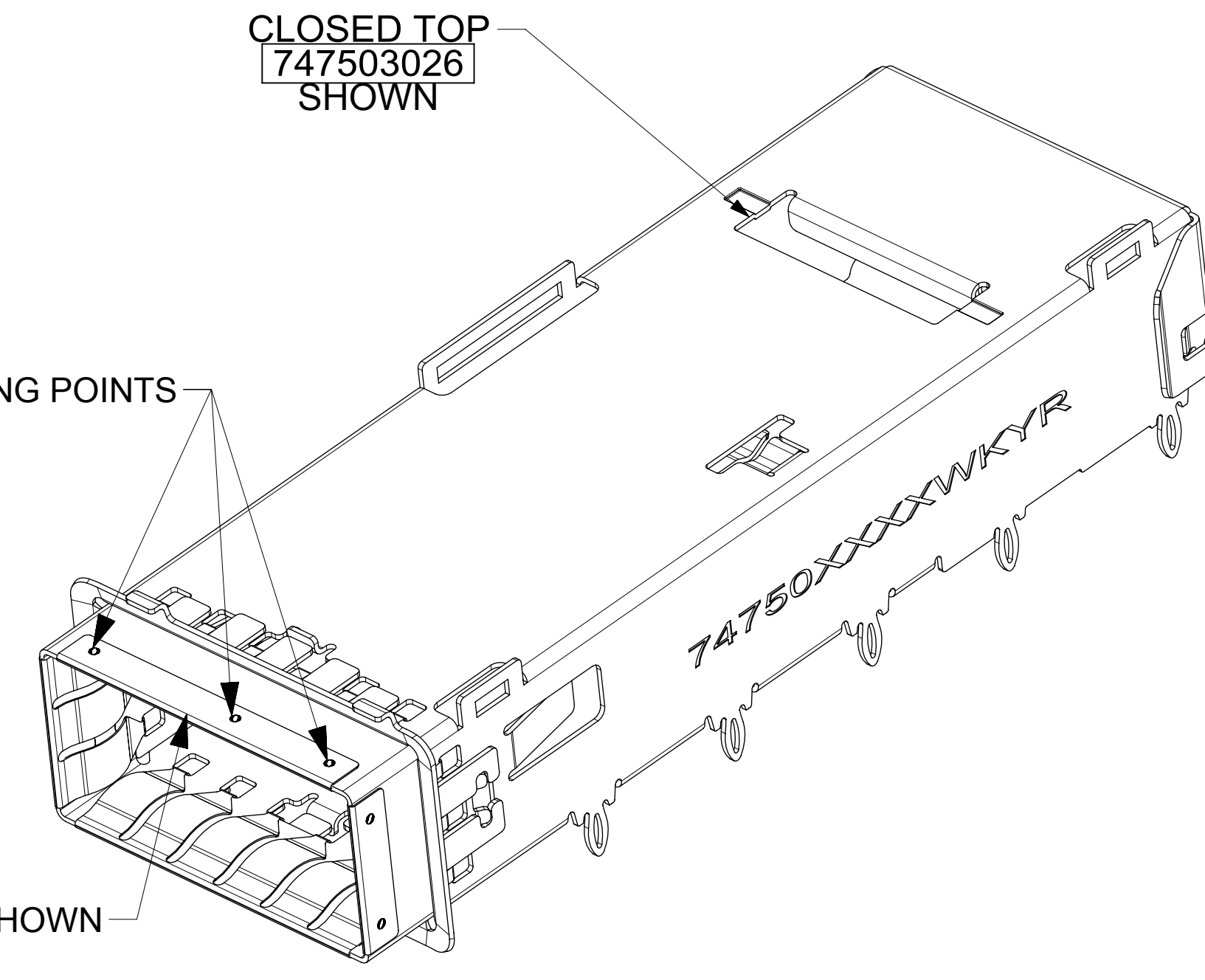
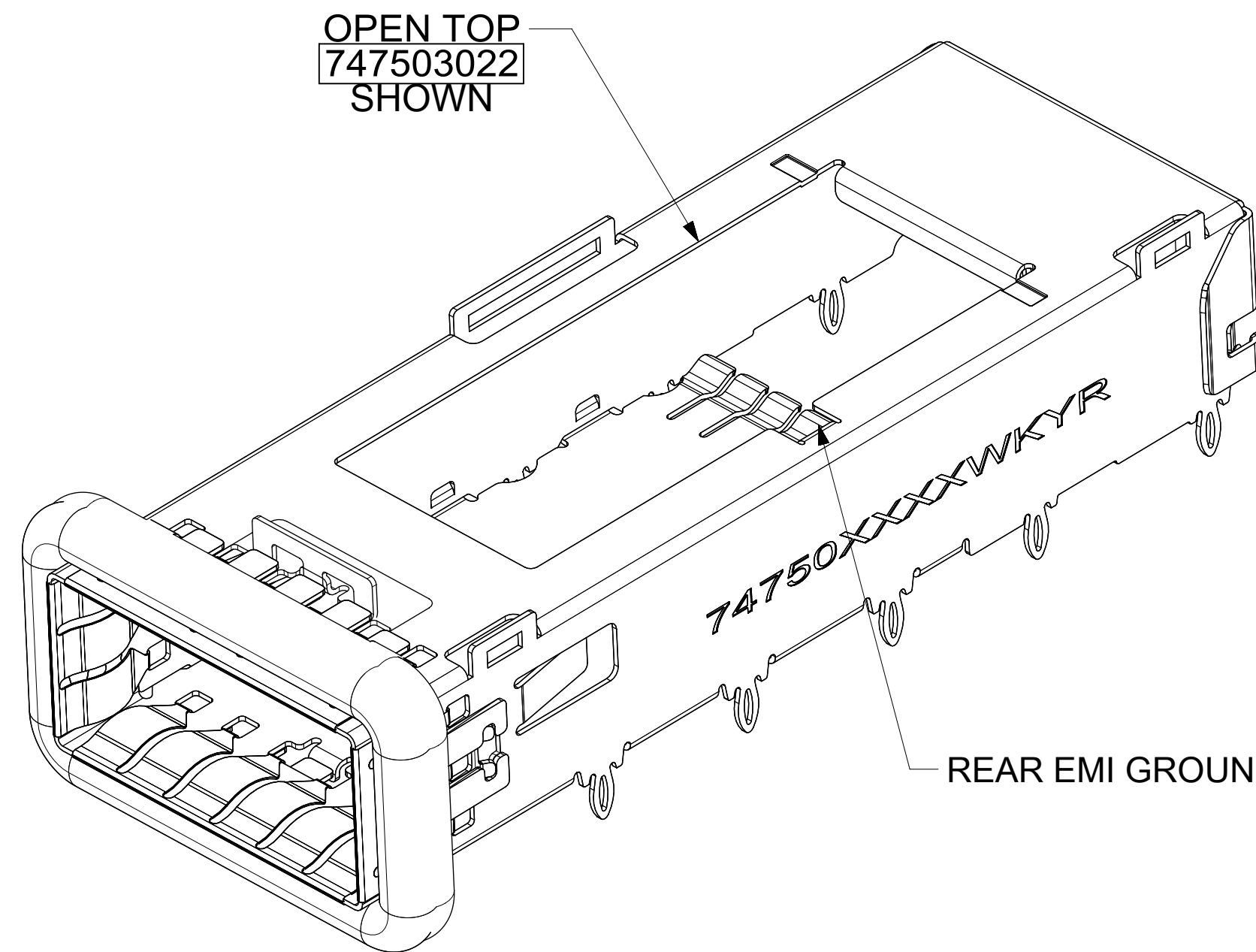

LASER WELDING POINTS
(SEE NOTE 7)

GASKET NOT SHOWN
FOR CLARITY

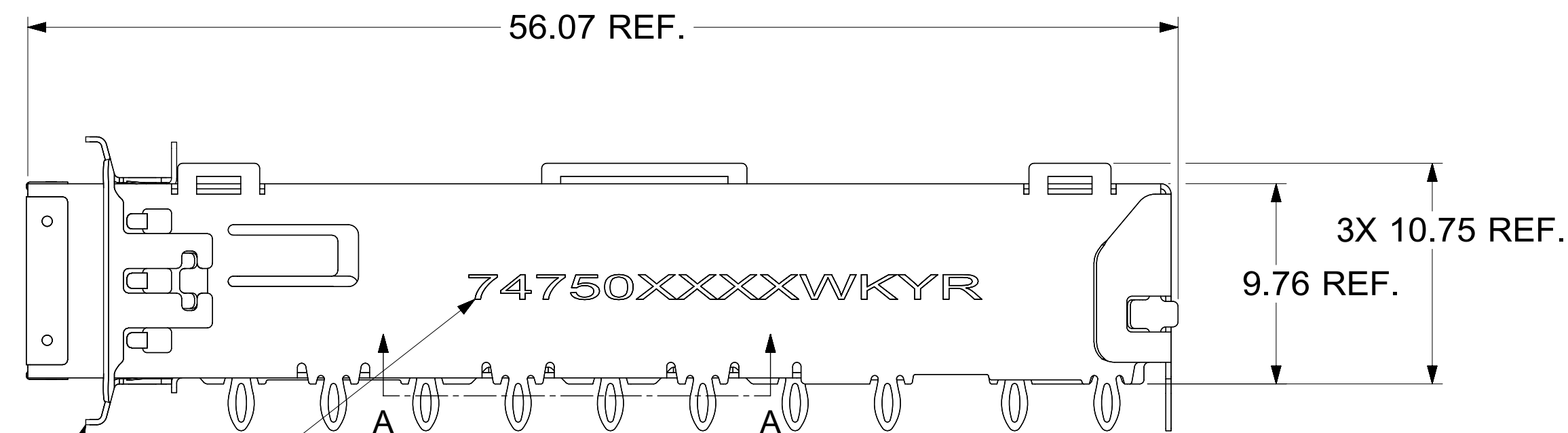

GASKET NOT SHOWN
FOR CLARITY

PN/DATE CODE TO BE PRINTED ON THE SIDE OF
COMPLETED CAGE ASSEMBLY APPROXIMATELY AS SHOWN.
SEE TABLE BELOW FOR DATE CODE INFORMATION.

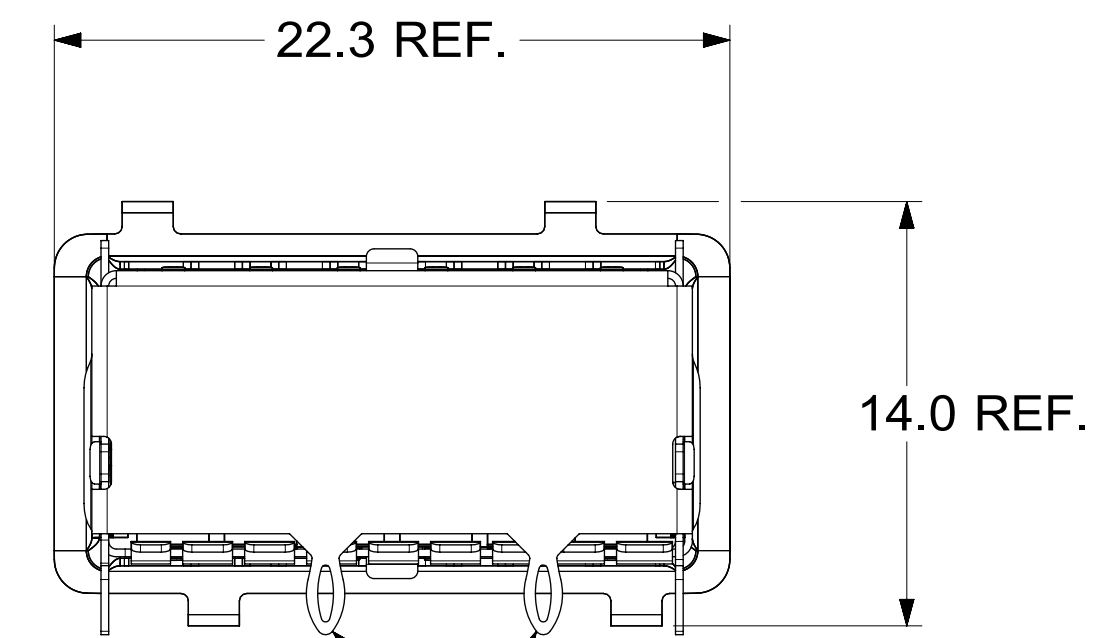

REAR PINS ARE OPTIONAL
(SEE CHART)

NOTE:
GASKET REMOVED FROM THIS
VIEW FOR CLARITY.

WEEK/YEAR DATE CODE TABLE	
WK	WEEK OF THE YEAR 01 THRU 52 (EXAMPLE: 01= FIRST WEEK OF YEAR 52= LAST WEEK OF YEAR)
YR	22, 23, 24 ETC.. (EXAMPLE: YEAR 2022= 22)

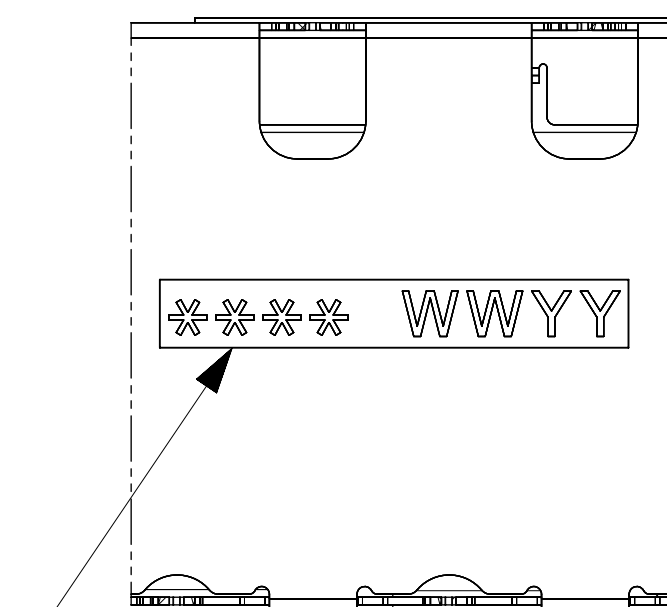

SECTION A-A

- NOTES:
- PRESS FIT LEGS 2.28mm LONG
 - MATERIAL:
CAGE: 0.25mm THICK COPPER ALLOY, NICKEL PLATED
SPRING FINGERS: STAINLESS STEEL
LIGHT PIPE/HEAT SINK CLIP: STAINLESS STEEL
LIGHT PIPES: POLYCARBONATE (UL 94-V0 RATED)
HEATSINKS: ALUMINUM (BLACK ANNOXIDIZED)
ELASTOMERIC GASKET: SILICON, COLOR BLACK
 - CUSTOM HEATSINKS AVAILABLE UPON REQUEST
 - QSFP+ ASSEMBLES ALSO AVAILABLE IN 1X2 (74767 SERIES),
1X3 (74768 SERIES), 1X4 (74769 SERIES) AND 1X6 (74771 SERIES).
 - PACKAGED IN TRAYS.
 - NO RoHS EXEMPTIONS.
 - WELD SPOTS MAY SHOW SLIGHT MATERIAL DISCOLORATION

THIS DRAWING CONTAINS INFORMATION THAT IS PROPRIETARY TO MOLEX ELECTRONIC TECHNOLOGIES, LLC AND SHOULD NOT BE USED WITHOUT WRITTEN PERMISSION											
DIMENSION UNITS mm		SCALE 1:1		CURRENT REV DESC:						molex	
GENERAL TOLERANCES (UNLESS SPECIFIED)				EC NO: 712623 DRWN: PKH 2022/05/27 CHK'D: DKUMARG 2022/06/29 APPR: SCHIEN 2022/07/07							
ANGULAR TOL ± 1.0°				INITIAL REVISION: DRWN: PKH 2022/05/27 APPR: SCHIEN 2022/07/07						PRODUCT CUSTOMER DRAWING	
4 PLACES ±		3 PLACES ±		2 PLACES ± 0.13		1 PLACE ± 0.25		0 PLACES ±		DRAFT WHERE APPLICABLE MUST REMAIN WITHIN DIMENSIONS	
THIRD ANGLE PROJECTION		DRAWING		SERIES		MATERIAL NUMBER		CUSTOMER		SHEET NUMBER	
D-SIZE		74750		SEE SHEET 4		PSD ASY A		1 OF 9			

CAGE ASSEMBLY OPTIONS

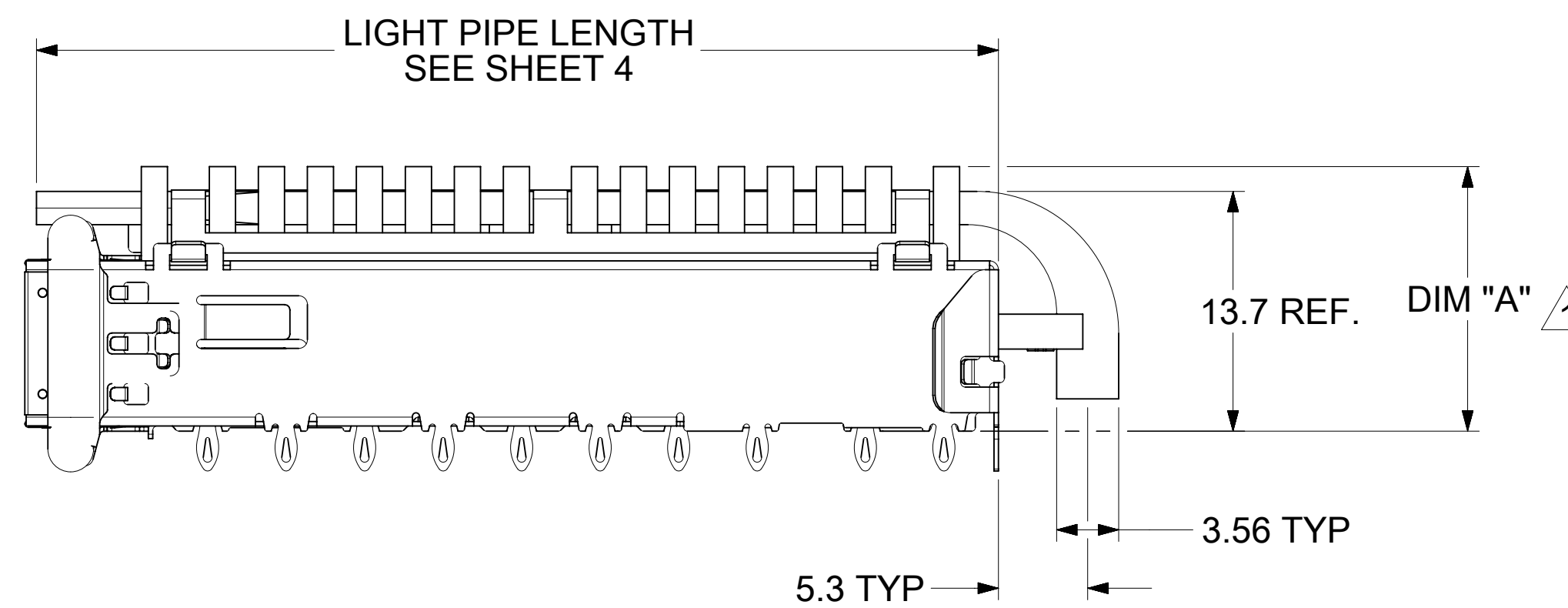
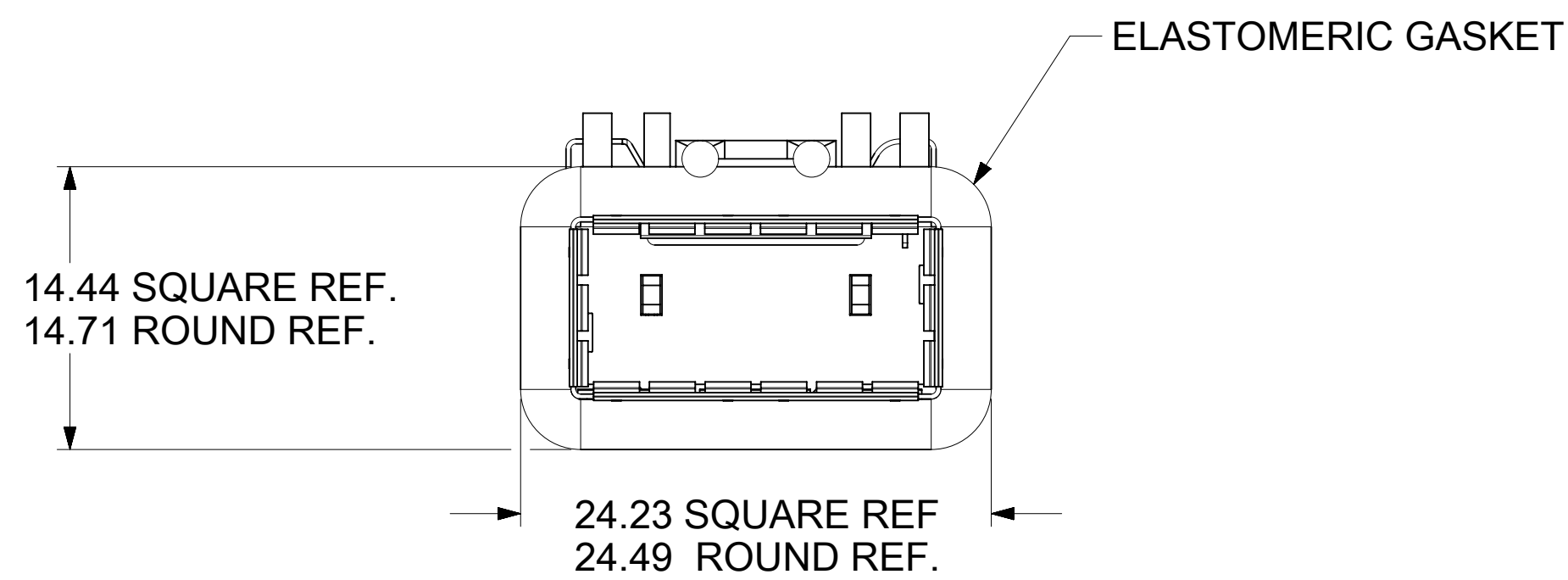
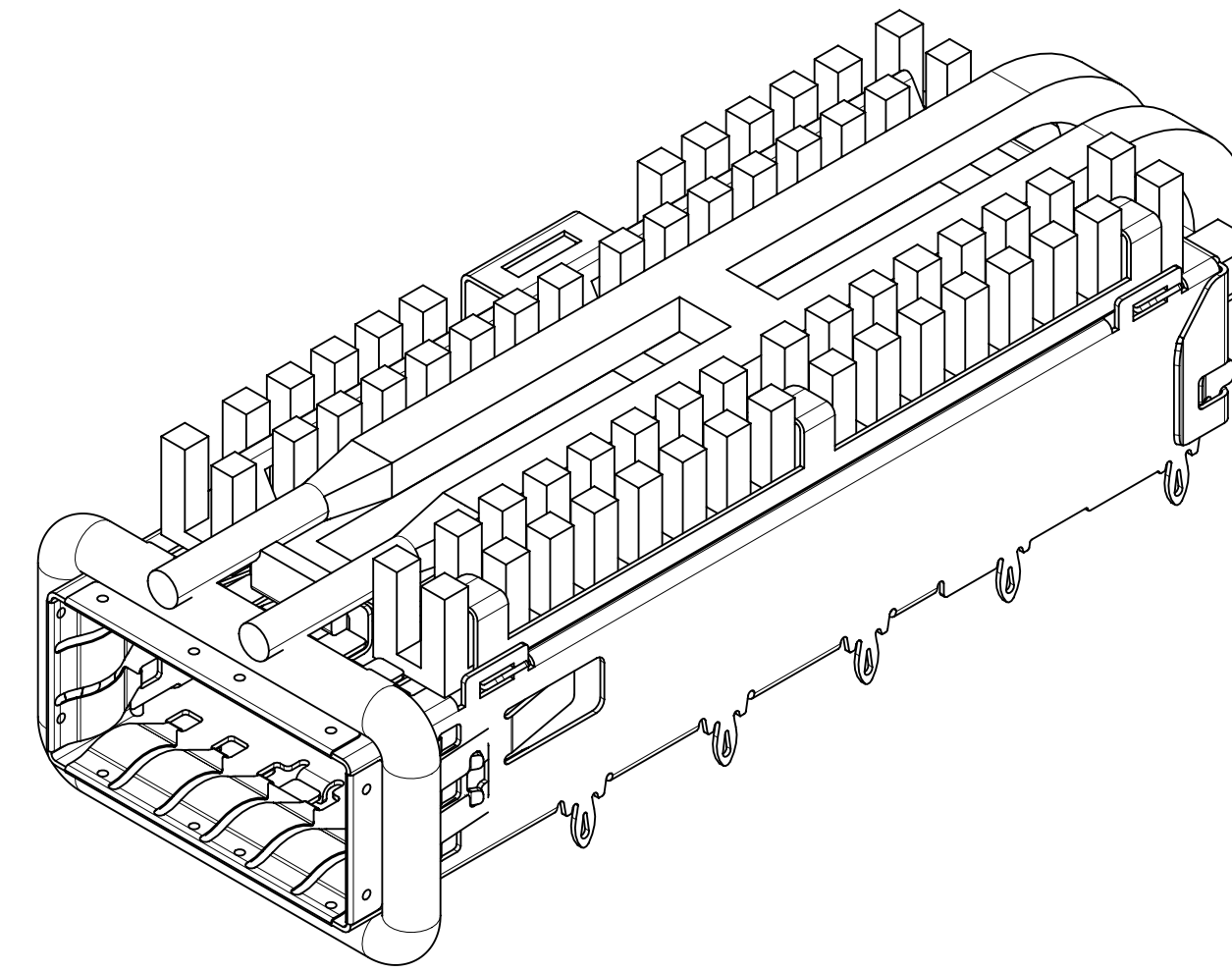
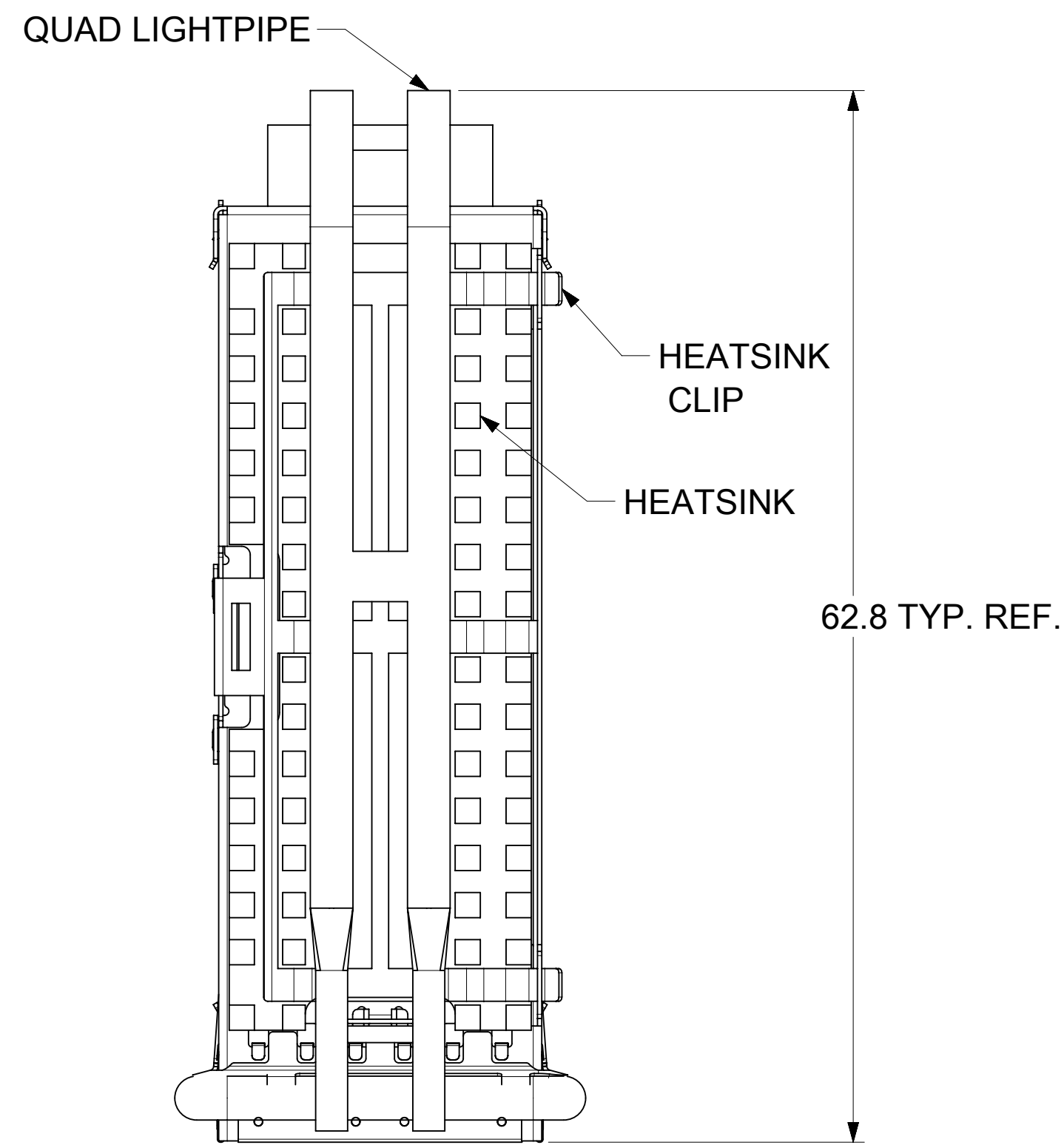

HEATSINK HEIGHT OPTIONS

OVERALL HEATSINK HEIGHT	DIM 'A'	TOL
PCI	13.7	+0.25
SAN	16.0	
NET	23.0	-0.73
CUSTOM	21.0	

¹ HEIGHT OF HEATSINK WITH MODULE INSERTED. DIMENSION MAY BE LESS DUE TO MODULE AND HEATSINK VARIATIONS.

THIS DRAWING CONTAINS INFORMATION THAT IS PROPRIETARY TO MOLEX ELECTRONIC TECHNOLOGIES, LLC AND SHOULD NOT BE USED WITHOUT WRITTEN PERMISSION			
DIMENSION UNITS mm	SCALE 3:1	CURRENT REV DESC:	
GENERAL TOLERANCES (UNLESS SPECIFIED)		EC NO: 712623	
ANGULAR TOL	± 1.0°	DRWN: PKH	2022/05/27
4 PLACES	±	CHK'D: DKUMARG	2022/06/29
3 PLACES	±	APPR: SCHIEN	2022/07/07
2 PLACES	± 0.13	INITIAL REVISION:	
1 PLACE	± 0.25	DRWN: PKH	2022/05/27
0 PLACES	±	APPR: SCHIEN	2022/07/07
DRAFT WHERE APPLICABLE MUST REMAIN WITHIN DIMENSIONS		THIRD ANGLE PROJECTION	DRAWING
			D-SIZE
		SERIES	74750
		MATERIAL NUMBER	SEE SHEET 4
		CUSTOMER	
		SHEET NUMBER	2 OF 9

QSFP+ 1X1 CAGE ASSEMBLY
W / ELASTOMERIC GASKET, SUS INNER SPRING FINGER (ROUND & SQUARE)

PRODUCT CUSTOMER DRAWING

DOCUMENT NUMBER: **747503022** DOC TYPE: PSD DOC PART: ASY REVISION: A

LEG OPTIONS

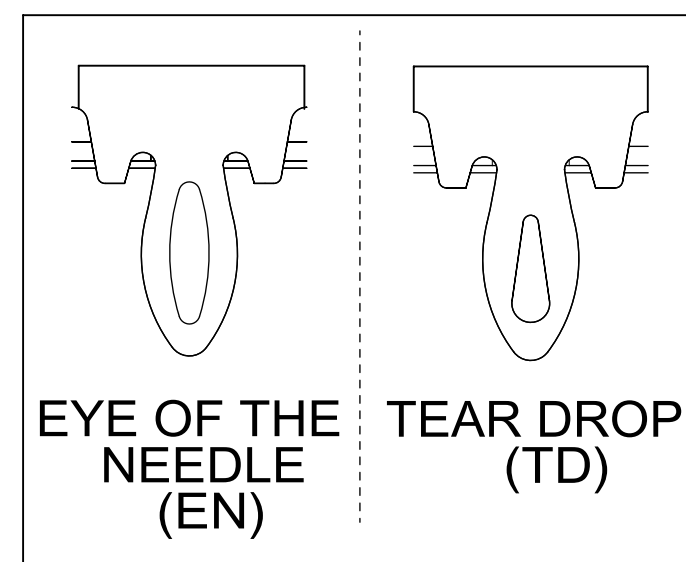

REAR LEG OPTIONS

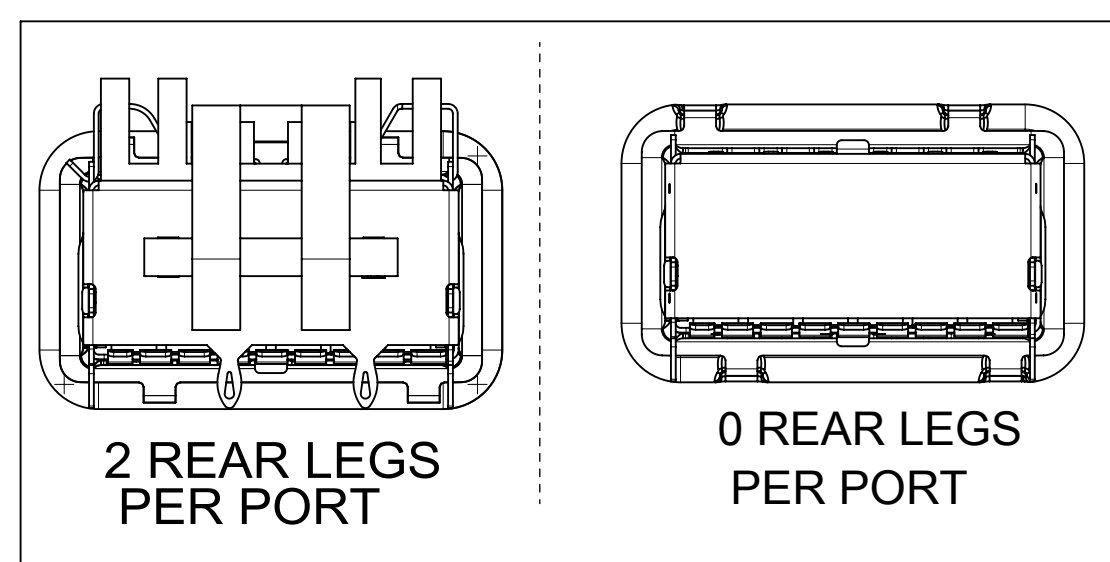

ELASTOMERIC GASKET OPTIONS

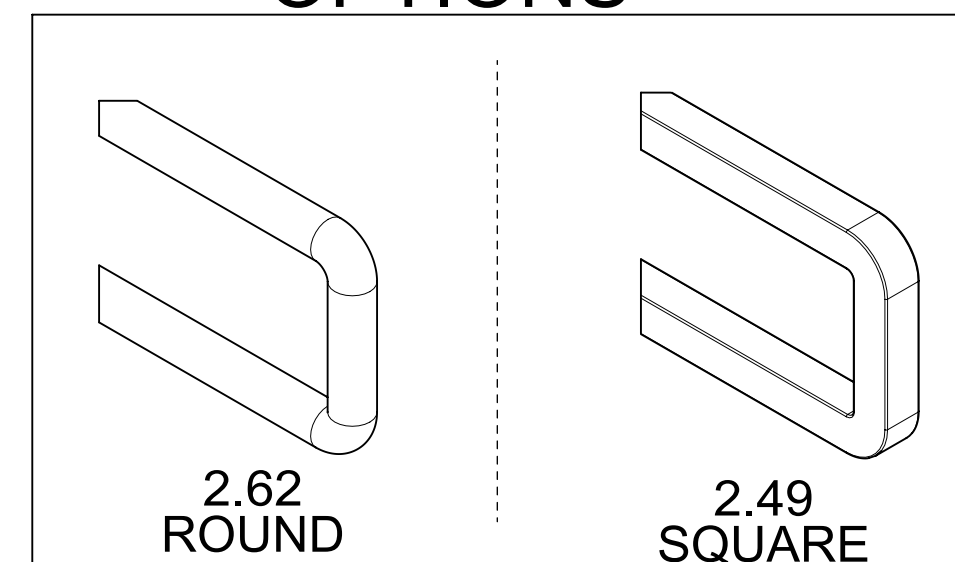

HEATSINK AND LIGHT PIPE OPTIONS

HEATSINK ONLY

SINGLE LIGHT PIPE

DUAL LIGHT PIPE

QUAD LIGHT PIPE

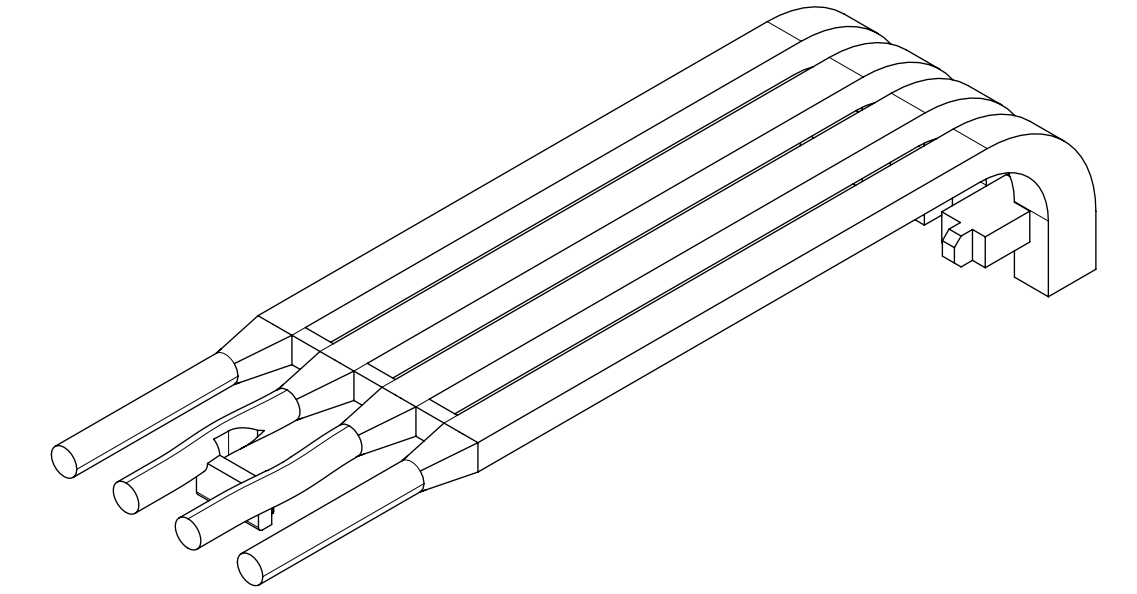
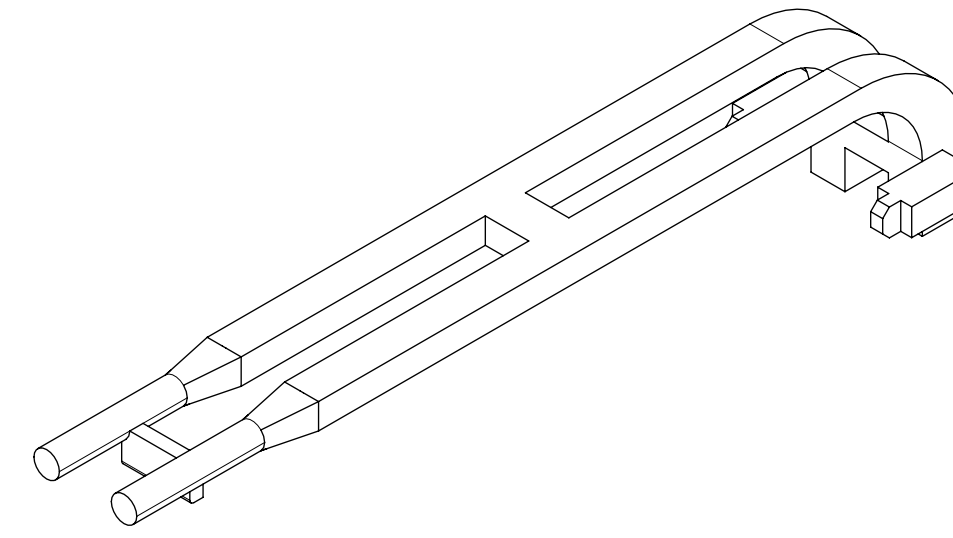
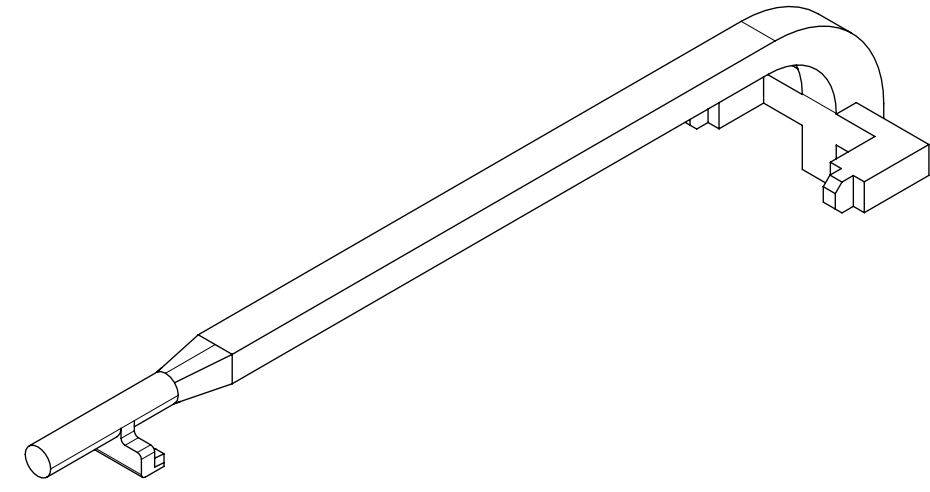

PIN FIELD HEATSINK FOR NO LIGHT PIPE

PIN FIELD HEATSINK FOR SINGLE LIGHT PIPE

PIN FIELD HEATSINK FOR DUAL LIGHT PIPE

PIN FIELD HEATSINK FOR QUAD LIGHT PIPE

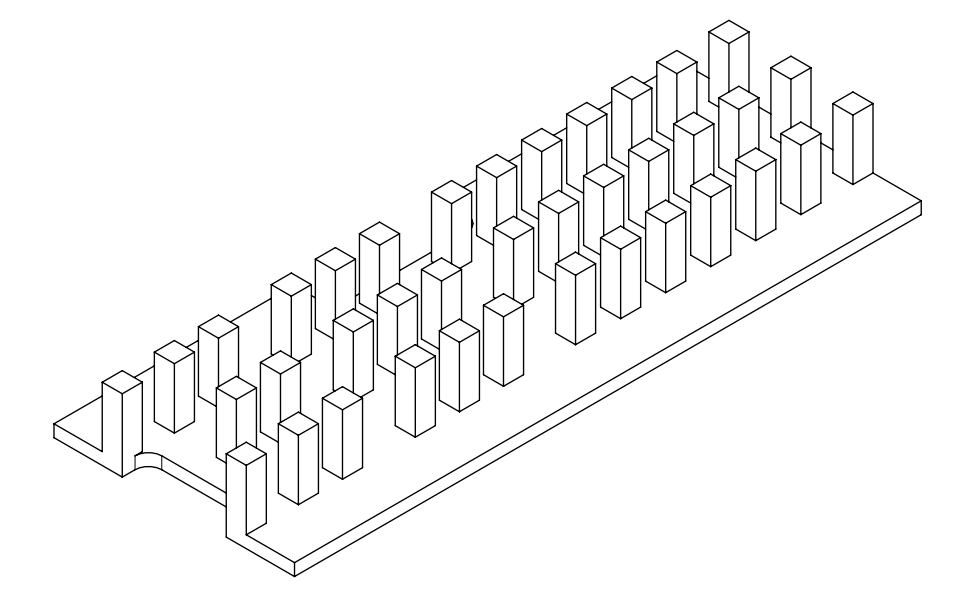
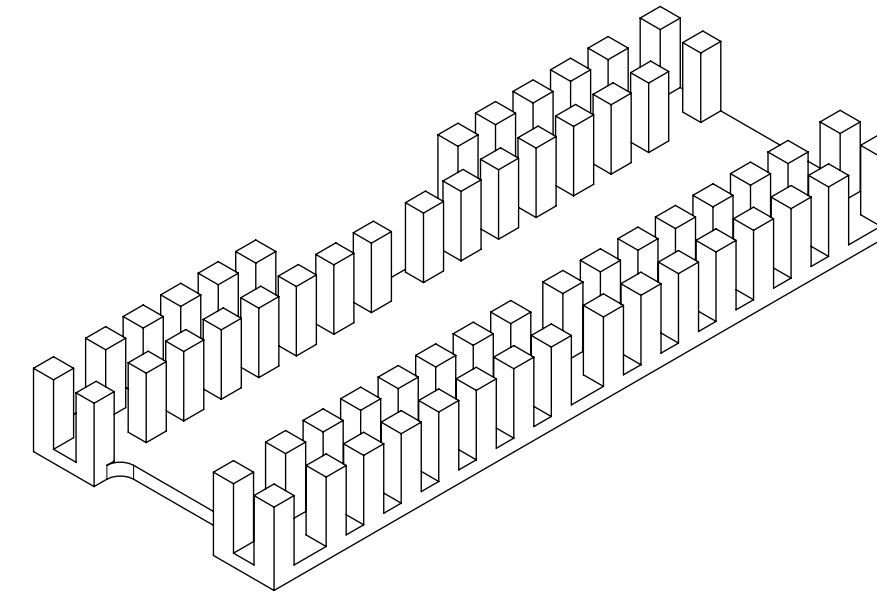
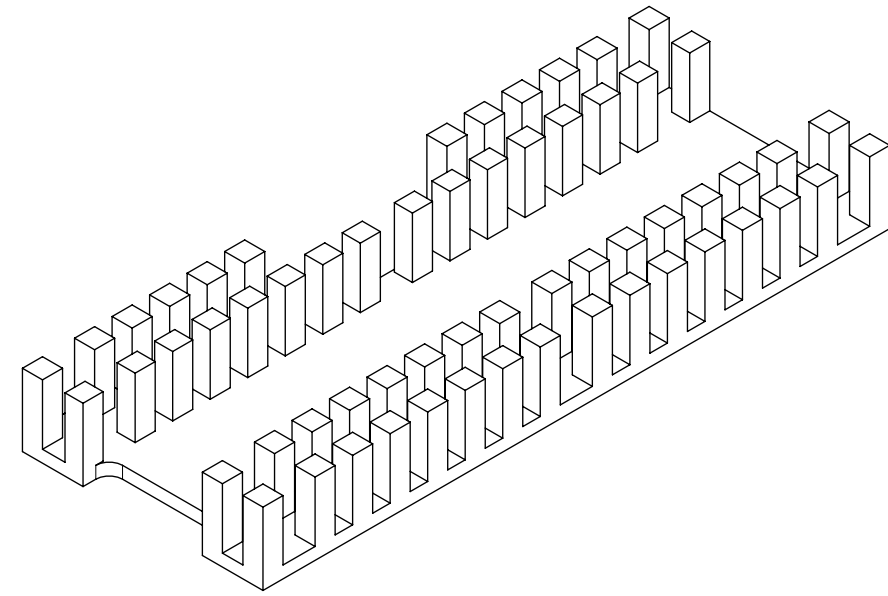
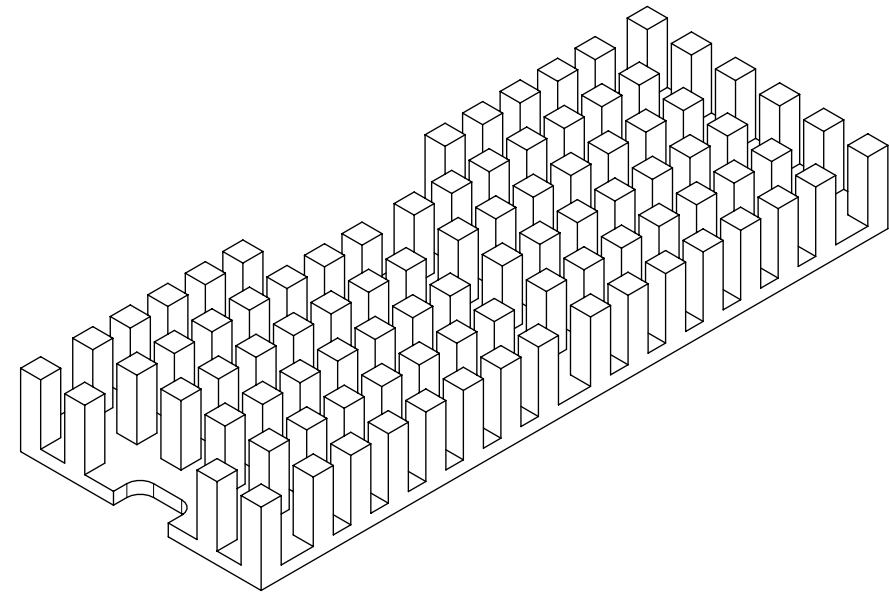

NOTES:
 1. MATERIALS:
 LIGHT PIPE: LEXAN 940A
 HEATSINK: ALUMINUM (BLACK ANNOXIDIZED)

THIS DRAWING CONTAINS INFORMATION THAT IS PROPRIETARY TO MOLEX ELECTRONIC TECHNOLOGIES, LLC AND SHOULD NOT BE USED WITHOUT WRITTEN PERMISSION											
DIMENSION UNITS		SCALE		CURRENT REV DESC:						molex	
mm		2.5:1									
GENERAL TOLERANCES (UNLESS SPECIFIED)				EC NO: 712623						DOCUMENT NUMBER	
ANGULAR TOL ± 1.0°				DRWN: PKH 2022/05/27						DOC TYPE	
4 PLACES ±				CHK'D: DKUMARG 2022/06/29						DOC PART	
3 PLACES ±				APPR: SCHIEN 2022/07/07						REVISION	
2 PLACES ± 0.13				INITIAL REVISION:						DOCUMENT NUMBER	
1 PLACE ± 0.25				DRWN: PKH 2022/05/27						747503022	
0 PLACES ±				APPR: SCHIEN 2022/07/07						PSD ASY A	
DRAFT WHERE APPLICABLE MUST REMAIN WITHIN DIMENSIONS				THIRD ANGLE PROJECTION		DRAWING		SERIES		MATERIAL NUMBER	
						D-SIZE		74750		CUSTOMER	
								SEE SHEET 4		SHEET NUMBER	
										3 OF 9	

DOCUMENT STATUS	P1	RELEASE DATE	2022/07/07	13:29:38
-----------------	----	--------------	------------	----------

PART NUMBER SELECTION

NO HEATSINKS
NO LIGHT PIPES
747503026
SHOWN

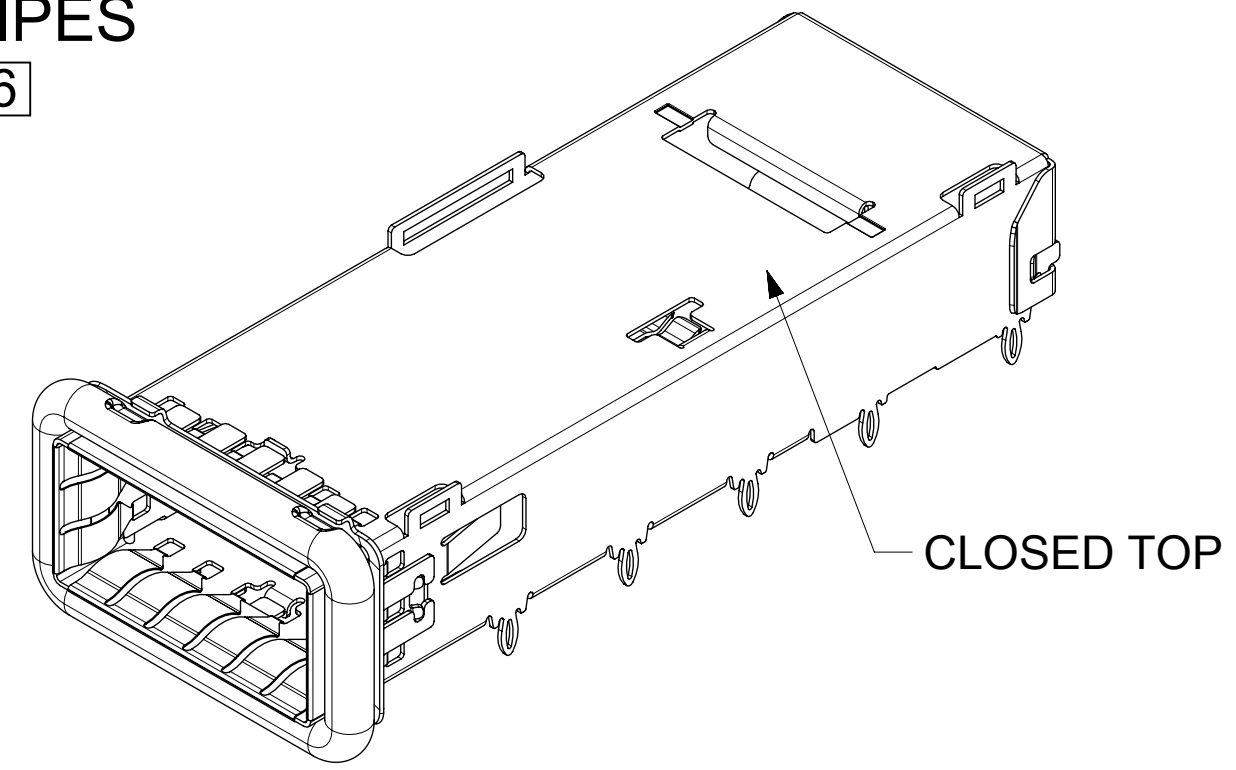

MOLEX P/N		LEG TYPE	# OF REAR LEGS PER PORT
WITH 2.62 REF ROUND ELASTOMERIC GASKET	WITH 2.49 REF SQUARE ELASTOMERIC GASKET		
747503026	---	EN	2

NO HEATSINKS
NO LIGHT PIPES
747503022
SHOWN

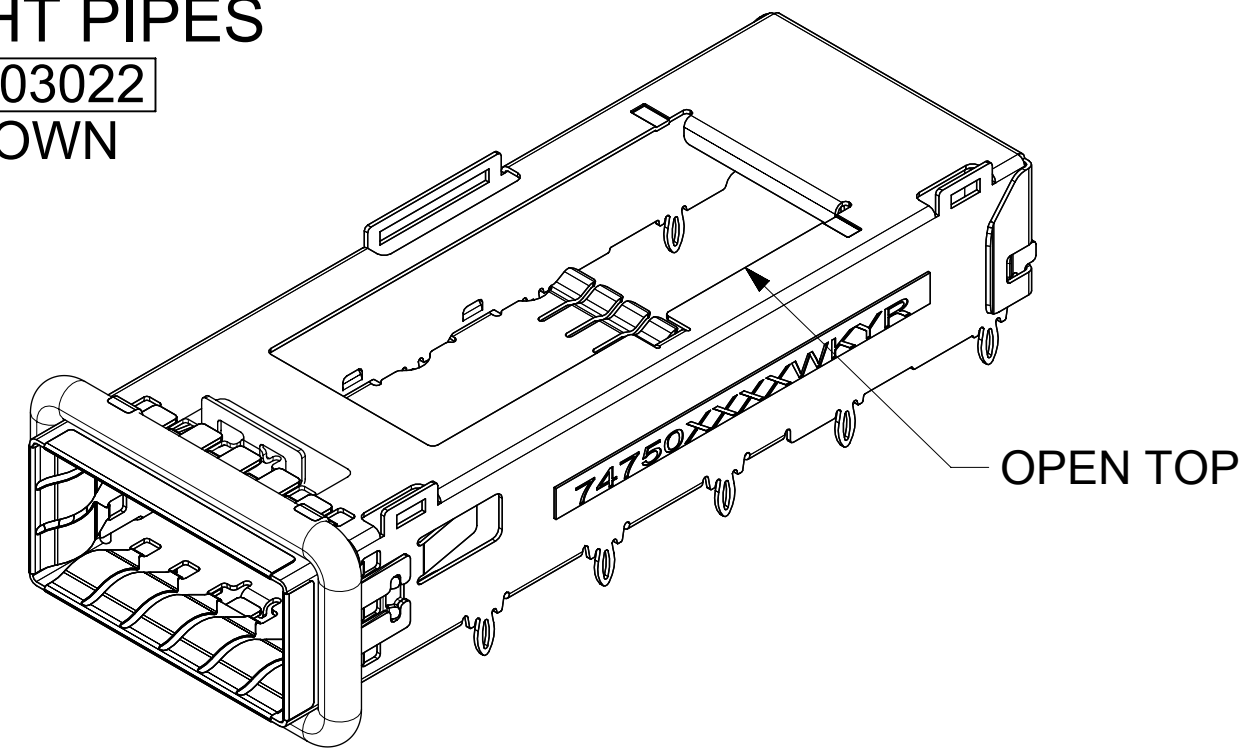

MOLEX P/N		LEG TYPE	# OF REAR LEGS PER PORT
WITH 2.62 REF ROUND ELASTOMERIC GASKET	WITH 2.49 REF SQUARE ELASTOMERIC GASKET		
747503022	---	EN	2
747503025	---	EN	-
747503094	---	EN	2
747503200	---	TD	2

WITH HEATSINKS
NO LIGHT PIPES
747503041
SHOWN

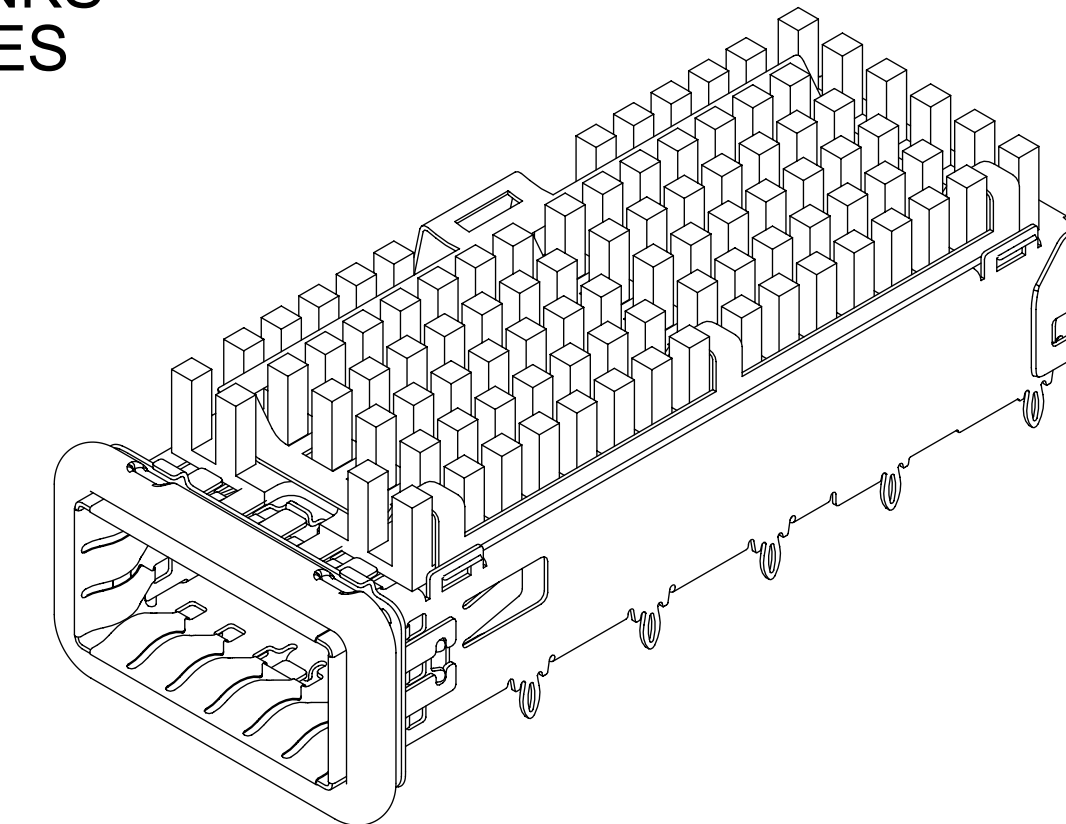

MOLEX P/N		HEAT-SINKS	LEG TYPE	# OF REAR LEGS PER PORT
WITH 2.62 REF ROUND ELASTOMERIC GASKET	WITH 2.49 REF SQUARE ELASTOMERIC GASKET			
747503041	---	SAN	EN	2
747503047	---	NET	EN	2
747503048	---	CUSTOM	EN	2
747503242	---	PCI	TD	2

WITH OR WITHOUT HEATSINKS AND LIGHT PIPES

MOLEX P/N		LIGHT PIPES	HEAT-SINKS	LEG TYPE	# OF REAR LEGS PER PORT	LIGHT PIPE LENGTH
WITH 2.62 REF ROUND ELASTOMERIC GASKET	WITH 2.49 REF SQUARE ELASTOMERIC GASKET					
747503070	---	SINGLE	SAN	EN	2	55.0
747503072	---	DUAL	SAN	EN	2	
747503073	---	DUAL	NET	EN	2	
747503571	---	QUAD	SAN	EN	2	55.0
747503577	---	DUAL	SAN	TD	2	
747503578	---	DUAL	NET	TD	2	

SINGLE LIGHT PIPE
747503070
SHOWN

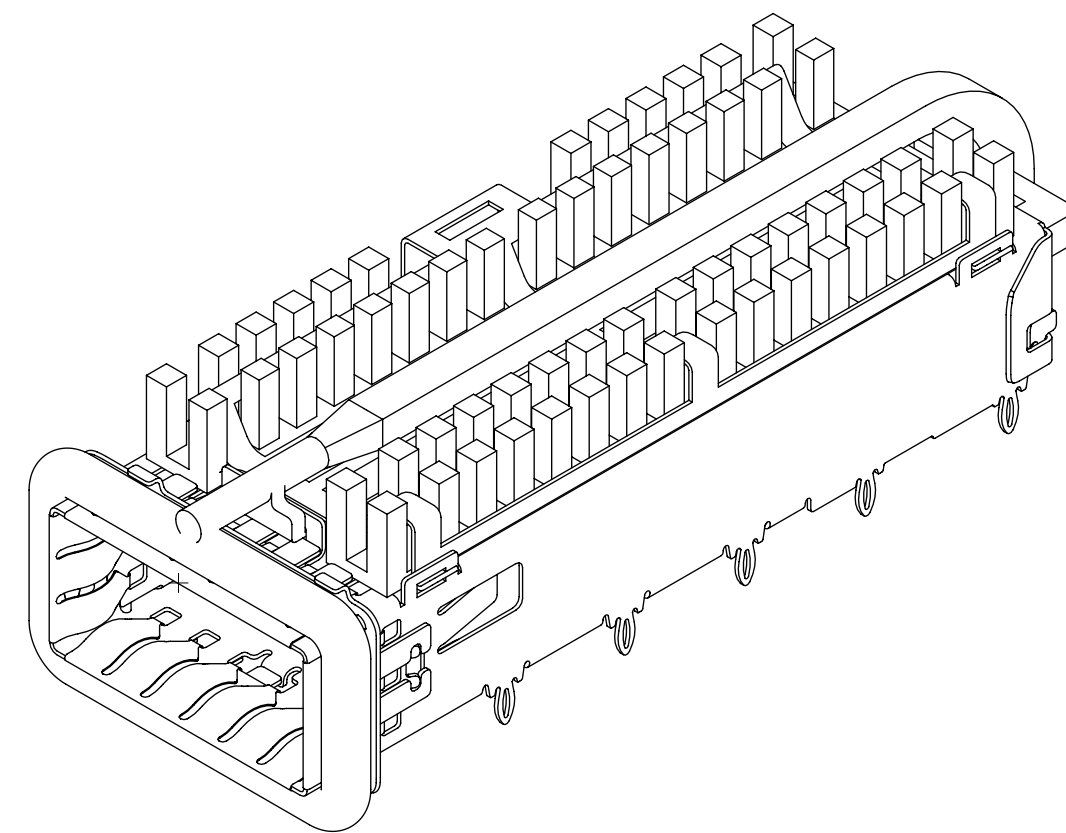

DUAL LIGHT PIPES
747503072
SHOWN

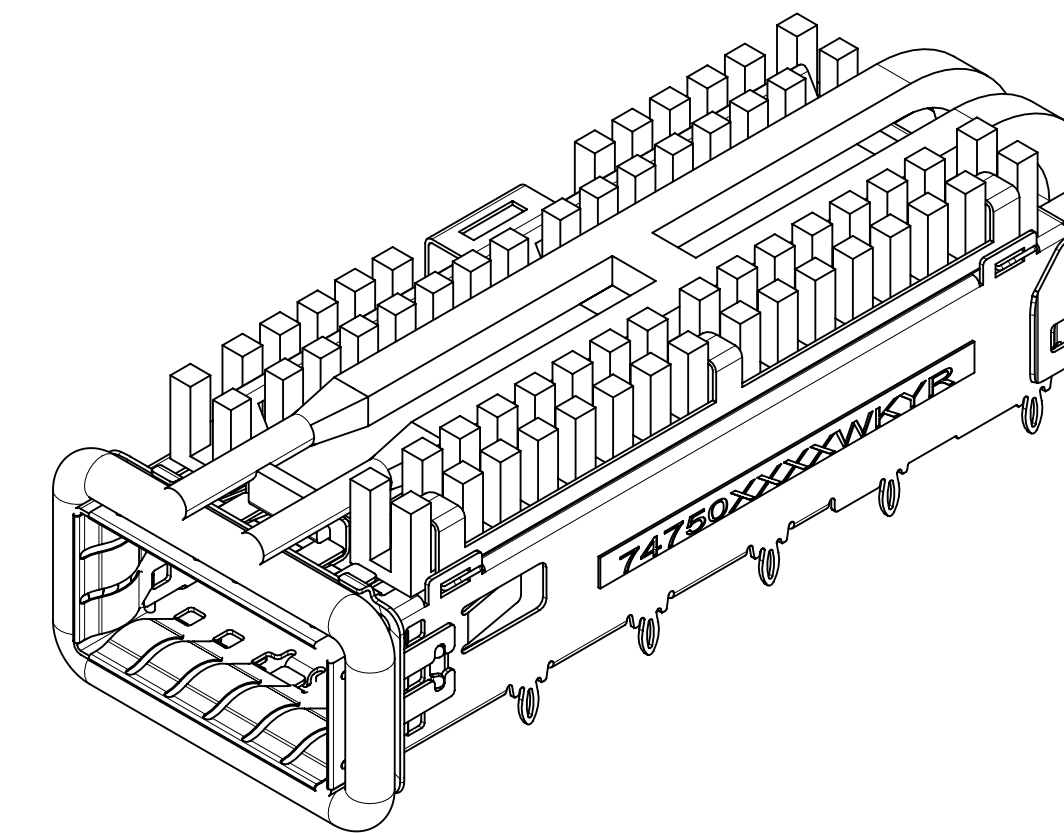

QUAD LIGHT PIPES
747503571
SHOWN

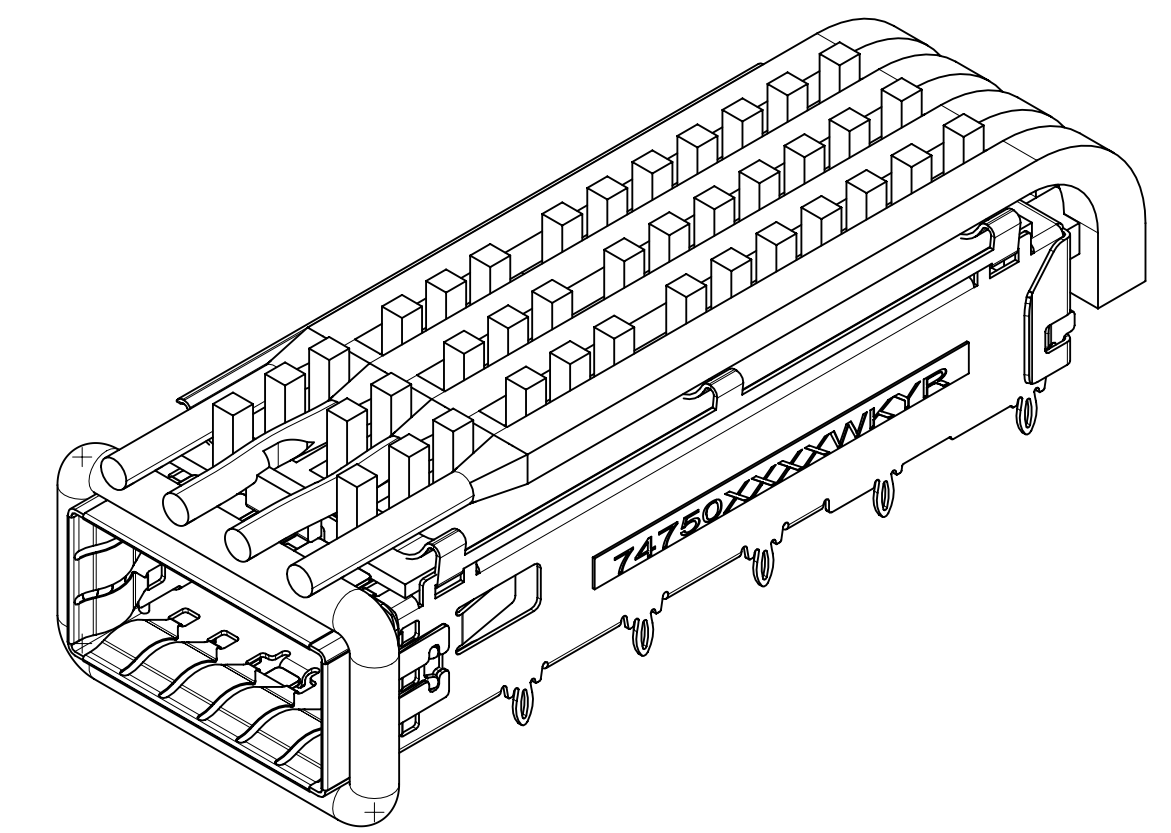

THIS DRAWING CONTAINS INFORMATION THAT IS PROPRIETARY TO MOLEX ELECTRONIC TECHNOLOGIES, LLC AND SHOULD NOT BE USED WITHOUT WRITTEN PERMISSION									
DIMENSION UNITS	SCALE	CURRENT REV DESC:							
mm	2.5:1								
GENERAL TOLERANCES (UNLESS SPECIFIED)									
ANGULAR TOL	± 1.0°								
4 PLACES	±	EC NO: 712623							
3 PLACES	±	DRWN: PKH 2022/05/27							
2 PLACES	± 0.13	CHK'D: DKUMARG 2022/06/29							
1 PLACE	± 0.25	APPR: SCHIEN 2022/07/07							
0 PLACES	±	INITIAL REVISION:							
DRAFT WHERE APPLICABLE MUST REMAIN WITHIN DIMENSIONS		THIRD ANGLE PROJECTION		DRAWING		SERIES		MATERIAL NUMBER	
		D-SIZE		74750		SEE P/N TABLE		CUSTOMER	
								SHEET NUMBER	
								4 OF 9	

molex

QSFP+ 1X1 CAGE ASSEMBLY
W / ELASTOMERIC GASKET, SUS INNER SPRING FINGER (ROUND & SQUARE)

PRODUCT CUSTOMER DRAWING

DOCUMENT NUMBER	DOC TYPE	DOC PART	REVISION
747503022	PSD	ASY	A

NOTE:
1. LEG TYPE:
EN - EYE OF THE NEEDLE
TD - TEAR DROP

DOCUMENT STATUS	P1	RELEASE DATE	2022/07/07	13:29:38
-----------------	----	--------------	------------	----------

PCB LAYOUT FOR SINGLE SIDED APPLICATIONS

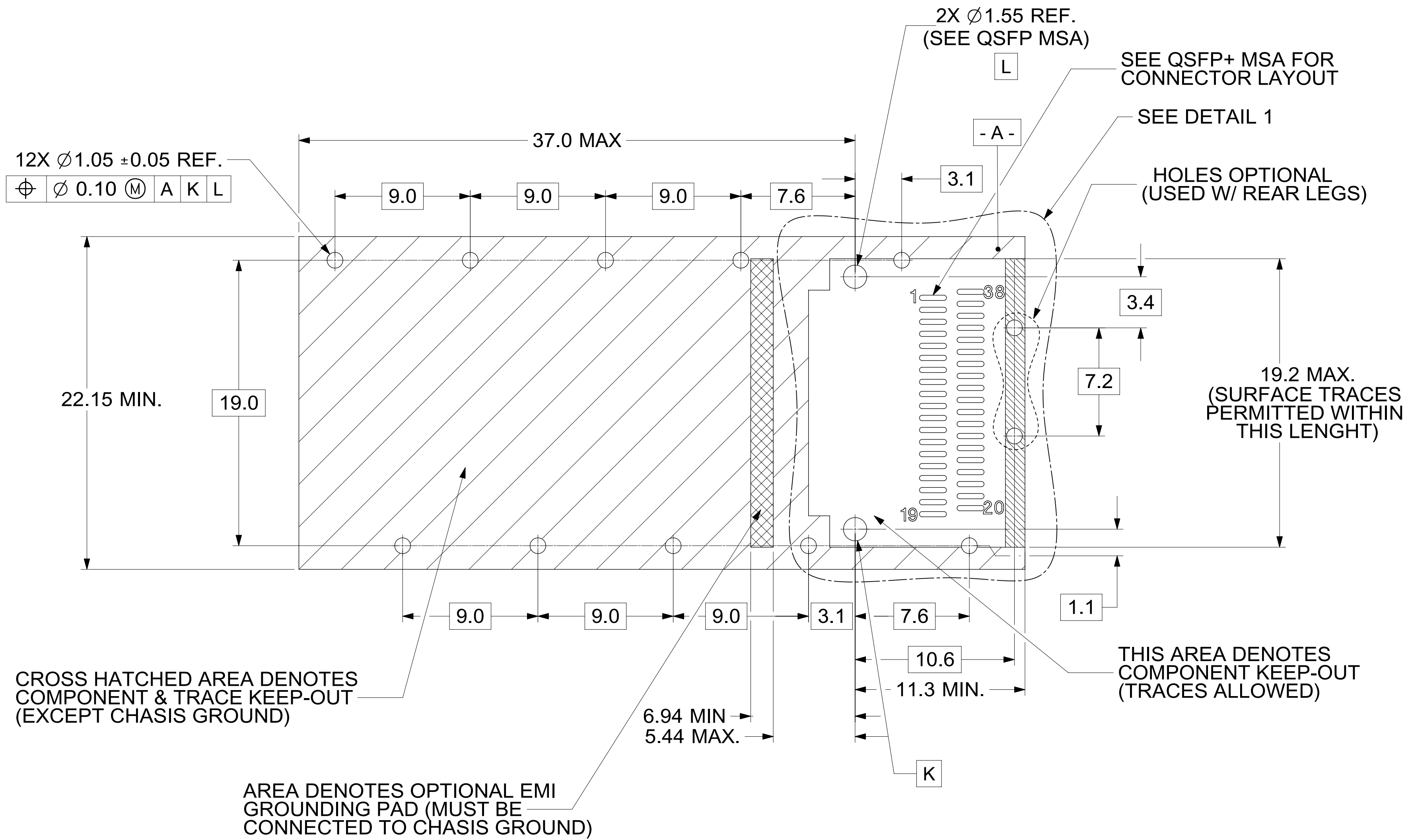

- NOTES:
- DATUM -A- IS TOP SURFACE OF HOST BOARD PER MSA
 - FINISHED HOLE SIZE (AFTER PLATING)
 - DATUM -K- IS HOST BOARD THRU HOLE #1 TO ACCEPT CONNECTOR GUIDE POST PER MSA
 - DATUM -L- IS HOST BOARD THRU HOLE #2 TO ACCEPT CONNECTOR GUIDE POST PER MSA
 - SINGLE SIDED BOARD THICKNESS:
 NOMINAL: 1.60 mm
 MINIMUM: 1.44 mm

HOST CONNECTOR DETAIL

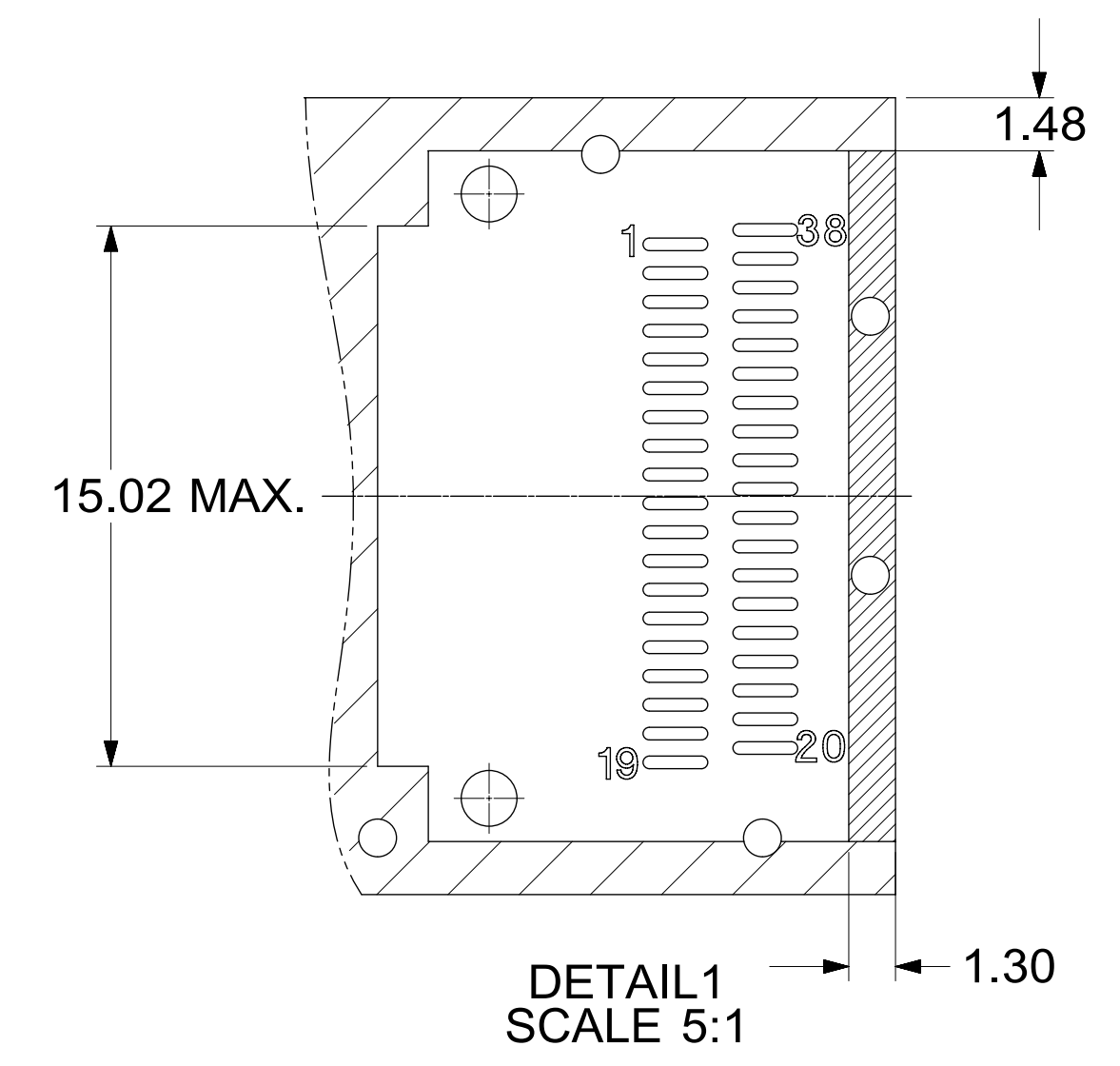

FOR CAGE ASSEMBLIES WITH LIGHT PIPES

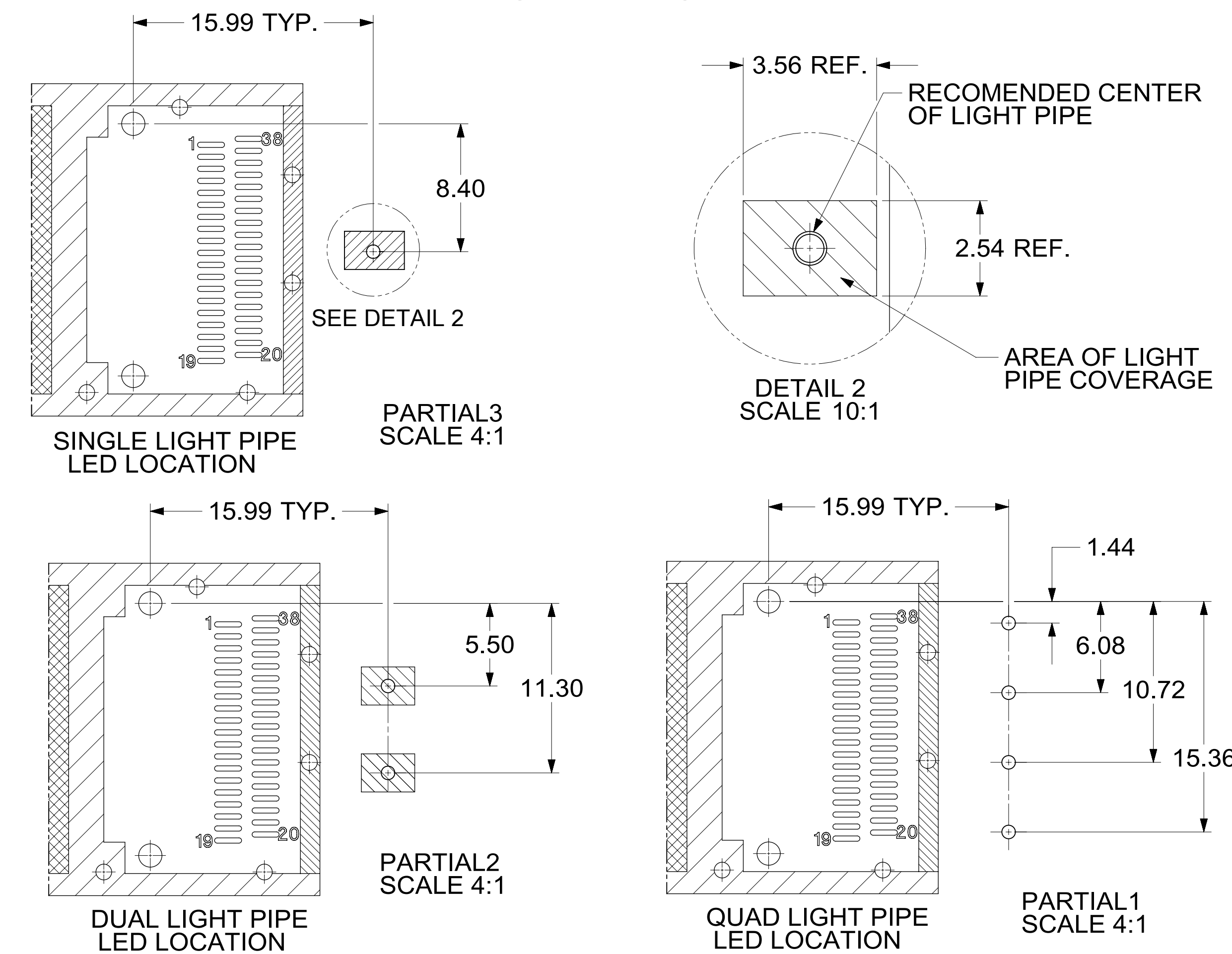

THIS DRAWING CONTAINS INFORMATION THAT IS PROPRIETARY TO MOLEX ELECTRONIC TECHNOLOGIES, LLC AND SHOULD NOT BE USED WITHOUT WRITTEN PERMISSION											
DIMENSION UNITS		SCALE		CURRENT REV DESC:							
mm		4:1									
GENERAL TOLERANCES (UNLESS SPECIFIED)				EC NO: 712623							
ANGULAR TOL $\pm 1.0^\circ$				DRWN: PKH 2022/05/27							
4 PLACES \pm				CHK'D: DKUMARG 2022/06/29							
3 PLACES \pm				APPR: SCHIEN 2022/07/07							
2 PLACES ± 0.13				INITIAL REVISION:							
1 PLACE ± 0.25				DRWN: PKH 2022/05/27							
0 PLACES \pm				APPR: SCHIEN 2022/07/07							
DRAFT WHERE APPLICABLE MUST REMAIN WITHIN DIMENSIONS			THIRD ANGLE PROJECTION		DRAWING		SERIES		MATERIAL NUMBER		
			D-SIZE		74750		74750		SEE SHEET 4		
DOCUMENT STATUS				P1		RELEASE DATE		2022/07/07 13:29:38		SHEET NUMBER	
										5 OF 9	



QSFP+ 1X1 CAGE ASSEMBLY
 W / ELASTOMERIC GASKET, SUS INNER SPRING
 FINGER (ROUND & SQUARE)

PRODUCT CUSTOMER DRAWING

DOCUMENT NUMBER: 747503022
 DOC TYPE: PSD
 DOC PART: ASY
 REVISION: A

PCB LAYOUT FOR BELLY-TO-BELLY APPLICATIONS

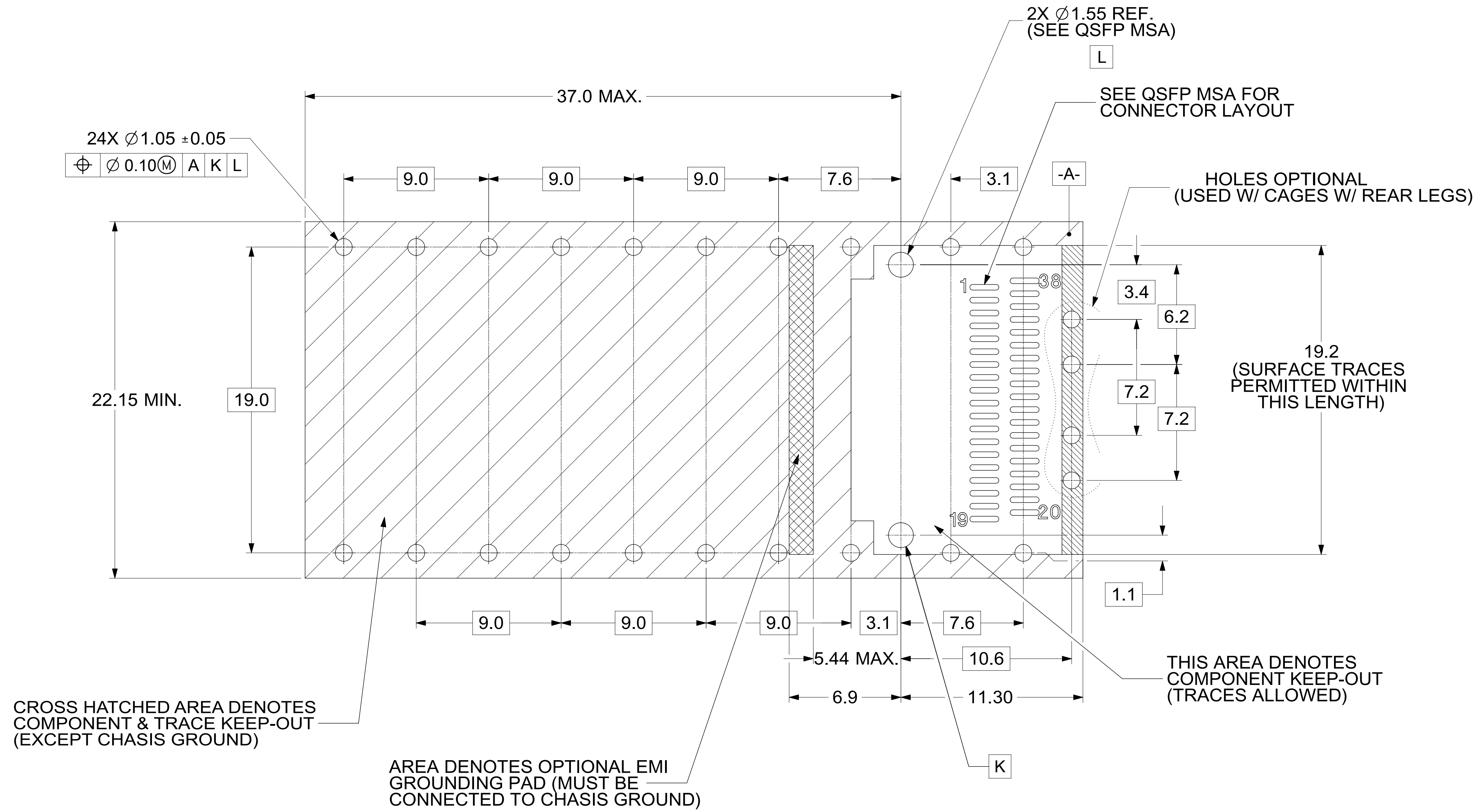

NOTE:
 FOR RECOMENDED CENTER
 OF LIGHT PIPES,
 SEE SHEET 5

- NOTES:
- DATUM -A- IS TOP SURFACE OF HOST BOARD PER MSA
 - FINISHED HOLE SIZE (AFTER PLATING)
 - DATUM -K- IS HOST BOARD THRU HOLE #1 TO ACCEPT CONNECTOR GUIDE POST PER MSA
 - DATUM -L- IS HOST BOARD THRU HOLE #2 TO ACCEPT CONNECTOR GUIDE POST PER MSA
 - BELLY TO BELLY BOARD THICKNESS:
 NOMINAL: 2.90 mm
 MINIMUM: 2.48 mm

THIS DRAWING CONTAINS INFORMATION THAT IS PROPRIETARY TO MOLEX ELECTRONIC TECHNOLOGIES, LLC AND SHOULD NOT BE USED WITHOUT WRITTEN PERMISSION									
DIMENSION UNITS	SCALE	CURRENT REV DESC:							
mm	6:1	<p>molex</p> <p>QSFP+ 1X1 CAGE ASSEMBLY W / ELASTOMERIC GASKET, SUS INNER SPRING FINGER (ROUND & SQUARE)</p> <p>PRODUCT CUSTOMER DRAWING</p> <p>DOCUMENT NUMBER: 747503022 DOC TYPE: PSD DOC PART: ASY REVISION: A</p> <p>MATERIAL NUMBER: SEE SHEET 4 CUSTOMER: SHEET NUMBER: 6 OF 9</p>							
GENERAL TOLERANCES (UNLESS SPECIFIED)									
ANGULAR TOL	$\pm 1.0^\circ$								
4 PLACES	\pm								
3 PLACES	\pm								
2 PLACES	± 0.13								
1 PLACE	± 0.25	EC NO: 712623	DRWN: PKH	2022/05/27					
0 PLACES	\pm	CHK'D: DKUMARG	2022/06/29						
DRAFT WHERE APPLICABLE MUST REMAIN WITHIN DIMENSIONS		APPR: SCHIEN	2022/07/07						
THIRD ANGLE PROJECTION		INITIAL REVISION:	DRWN: PKH	2022/05/27					
DRAWING		APPR: SCHIEN	2022/07/07						
D-SIZE		SERIES	74750						

BEZEL AND BOARD POSITION DIMENSIONS FOR SINGLE SIDE MOUNTING

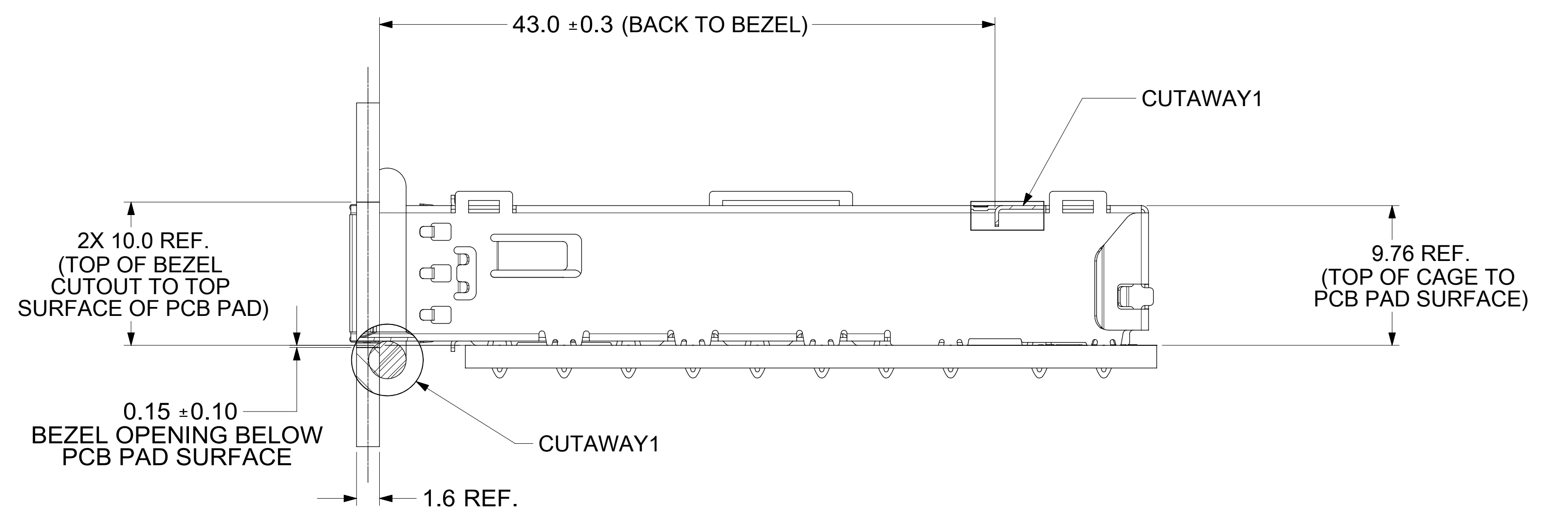
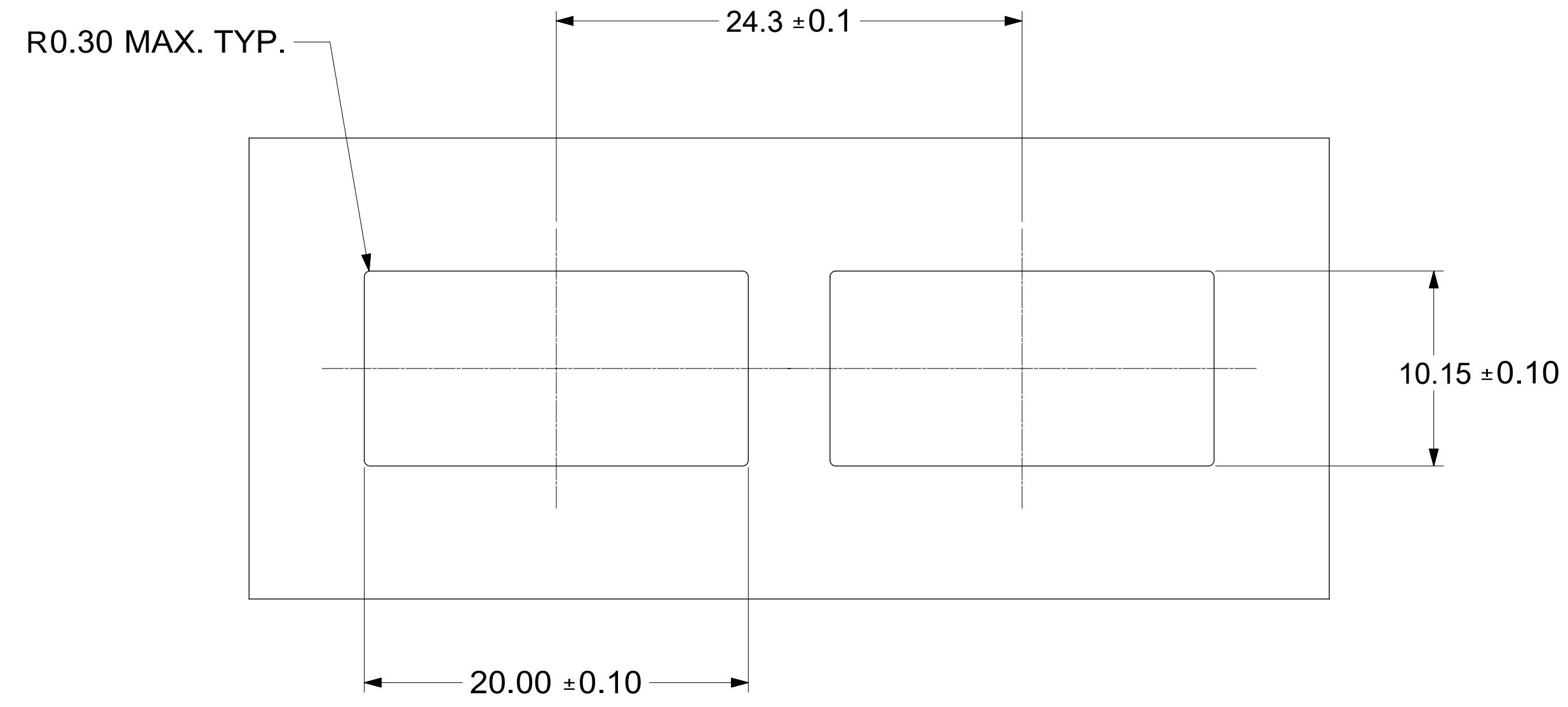

BEZEL AND BOARD POSITION DIMENSIONS FOR BELLY TO BELLY MOUNTING

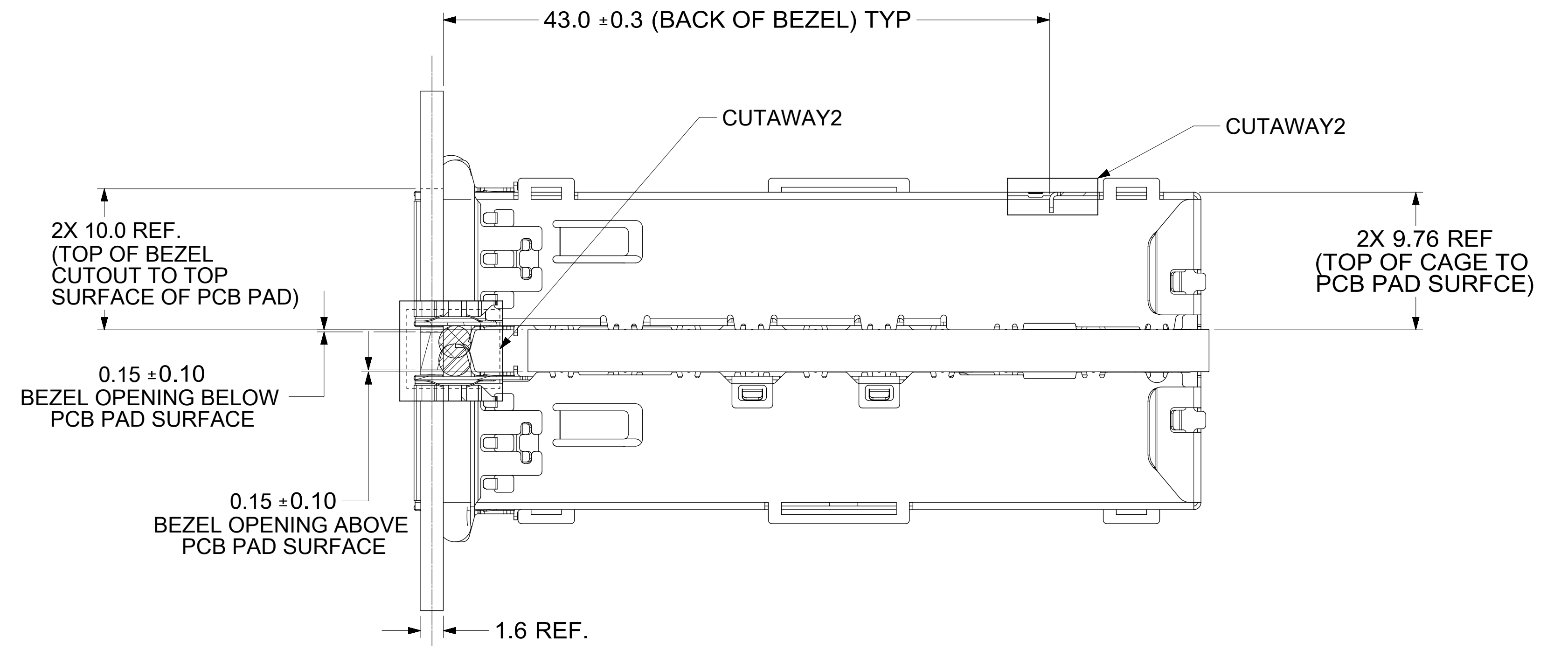
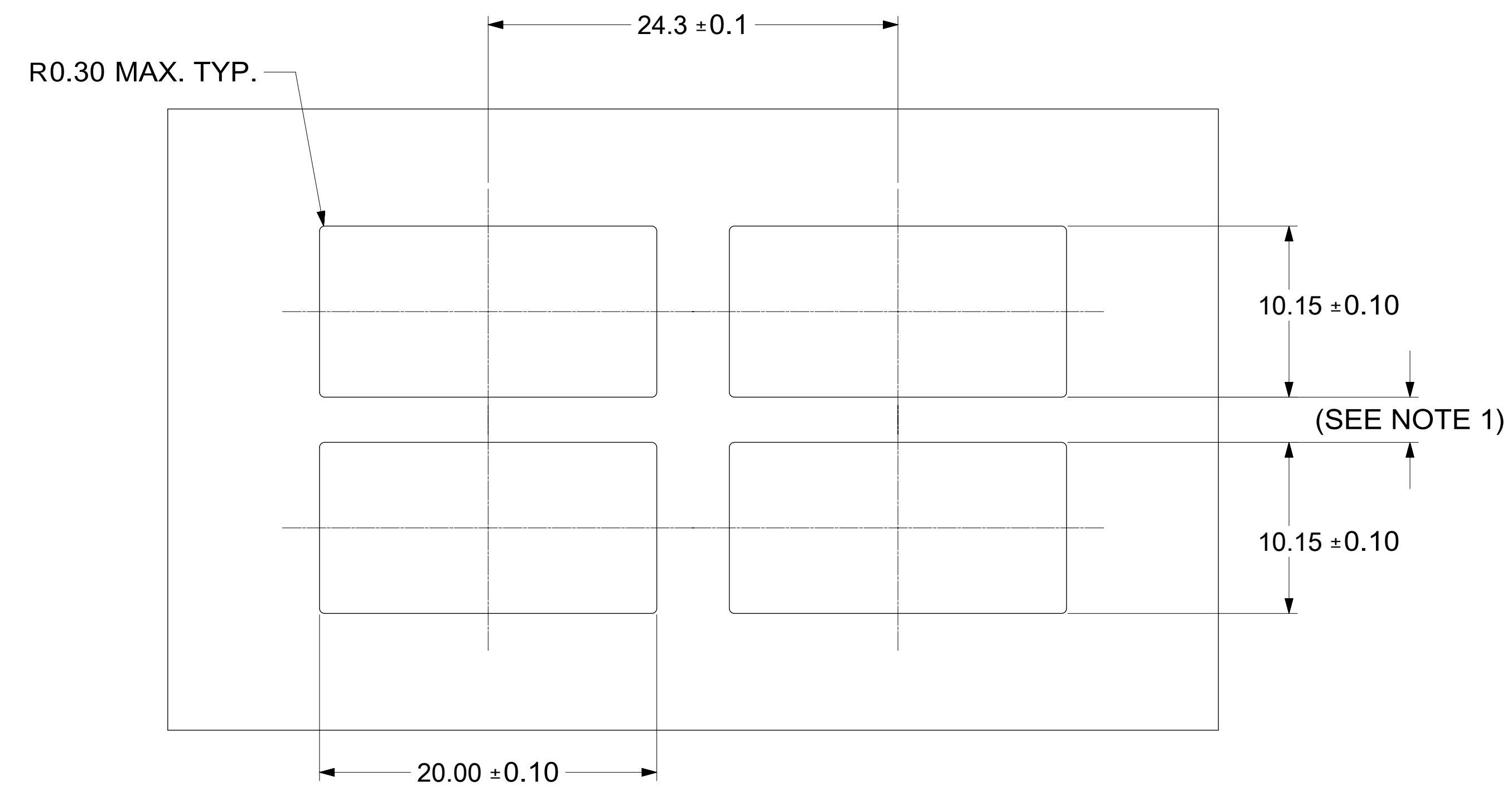

NOTE:
1. PCB THICKNESS VARIATION MUST BE CONSIDERED WHEN DETERMINING BEZEL OPENING, SIZE, AND LOCATION.

THIS DRAWING CONTAINS INFORMATION THAT IS PROPRIETARY TO MOLEX ELECTRONIC TECHNOLOGIES, LLC AND SHOULD NOT BE USED WITHOUT WRITTEN PERMISSION

DIMENSION UNITS mm	SCALE 4:1	CURRENT REV DESC:			
GENERAL TOLERANCES (UNLESS SPECIFIED)					
ANGULAR TOL	± 1.0°	EC NO: 712623	QSFP+ 1X1 CAGE ASSEMBLY W / ELASTOMERIC GASKET, SUS INNER SPRING FINGER (ROUND & SQUARE)		
4 PLACES	±	DRWN: PKH 2022/05/27			
3 PLACES	±	CHK'D: DKUMARG 2022/06/29	PRODUCT CUSTOMER DRAWING		
2 PLACES	± 0.13	APPR: SCHIEN 2022/07/07	DOCUMENT NUMBER		
1 PLACE	± 0.25	INITIAL REVISION:	747503022		
0 PLACES	±	DRWN: PKH 2022/05/27	DOC TYPE	DOC PART	REVISION
DRAFT WHERE APPLICABLE MUST REMAIN WITHIN DIMENSIONS		APPR: SCHIEN 2022/07/07	PSD	ASY	A
THIRD ANGLE PROJECTION		DRAWING	MATERIAL NUMBER		SHEET NUMBER
		D-SIZE	74750	SEE SHEET 4	7 OF 9

BEZEL LIGHT PIPE CUTOUT POSITION DIMENSIONS FOR SINGLE SIDE MOUNTING

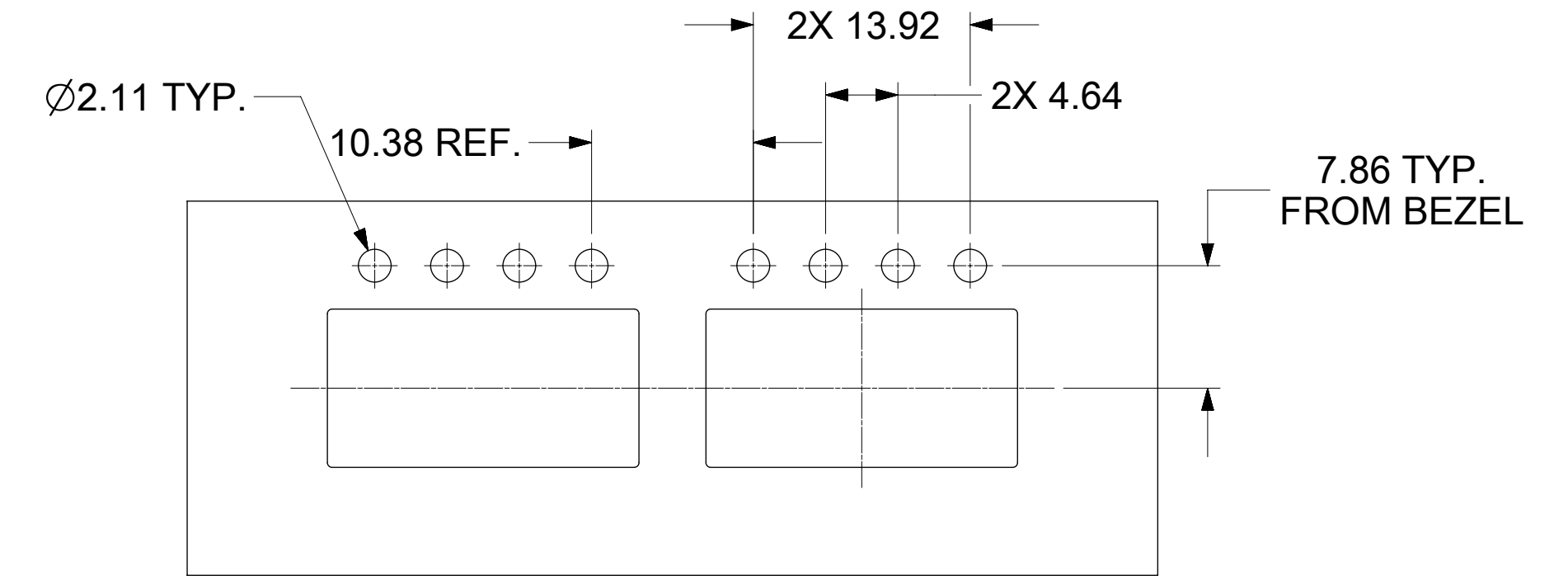
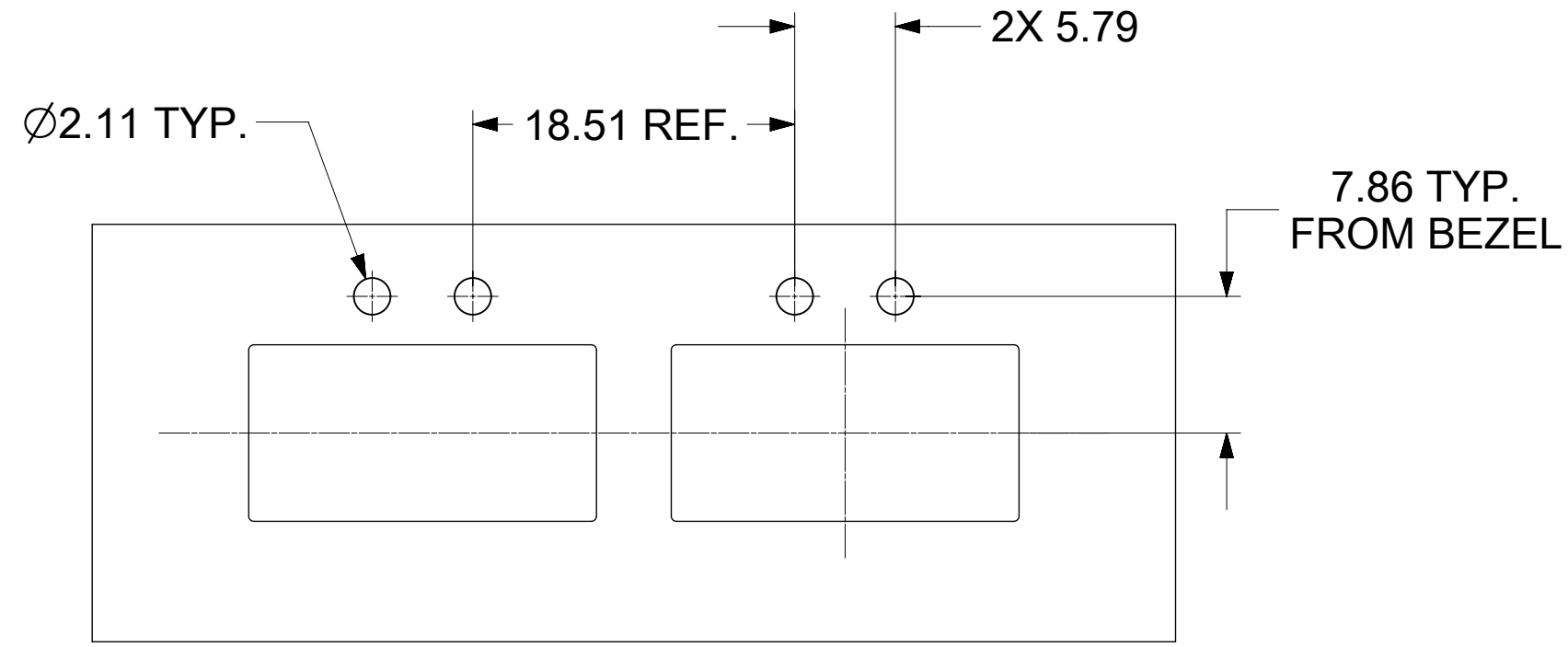
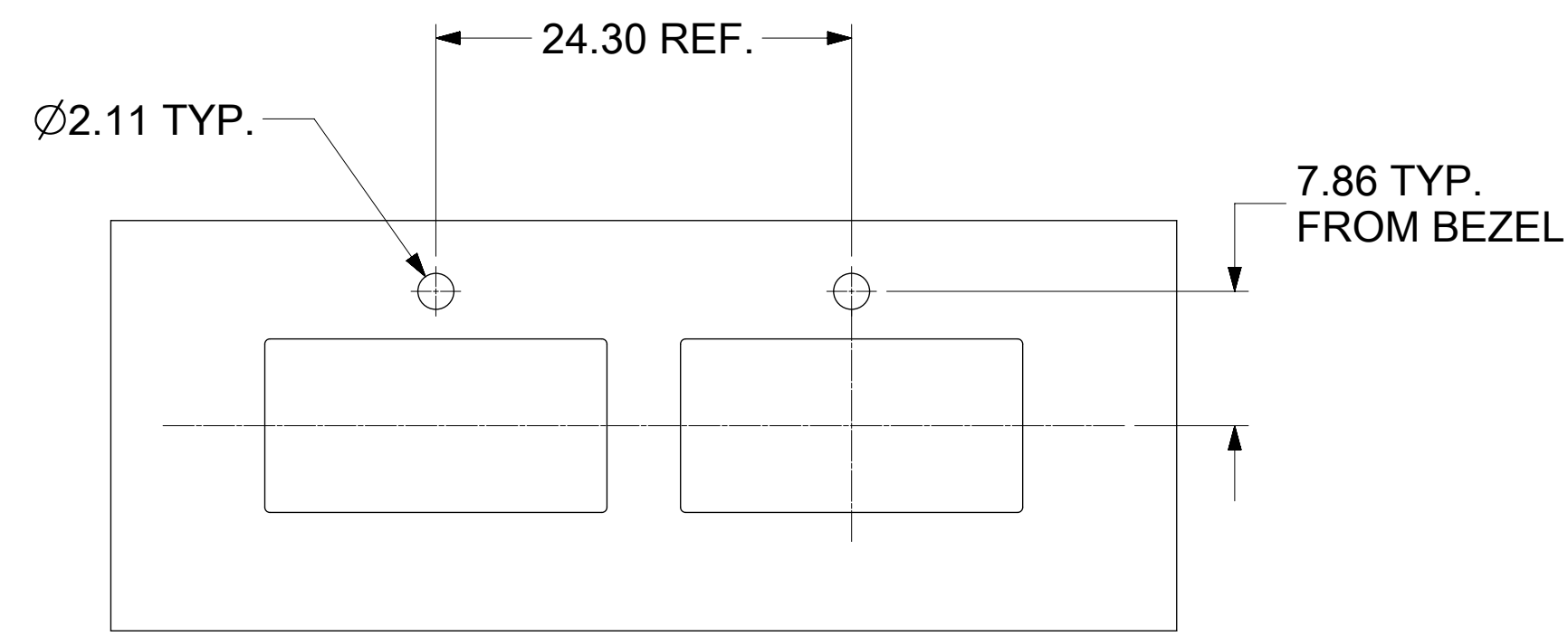

BEZEL LIGHT PIPE CUTOUT POSITION DIMENSIONS FOR BELLY-TO-BELLY MOUNTING

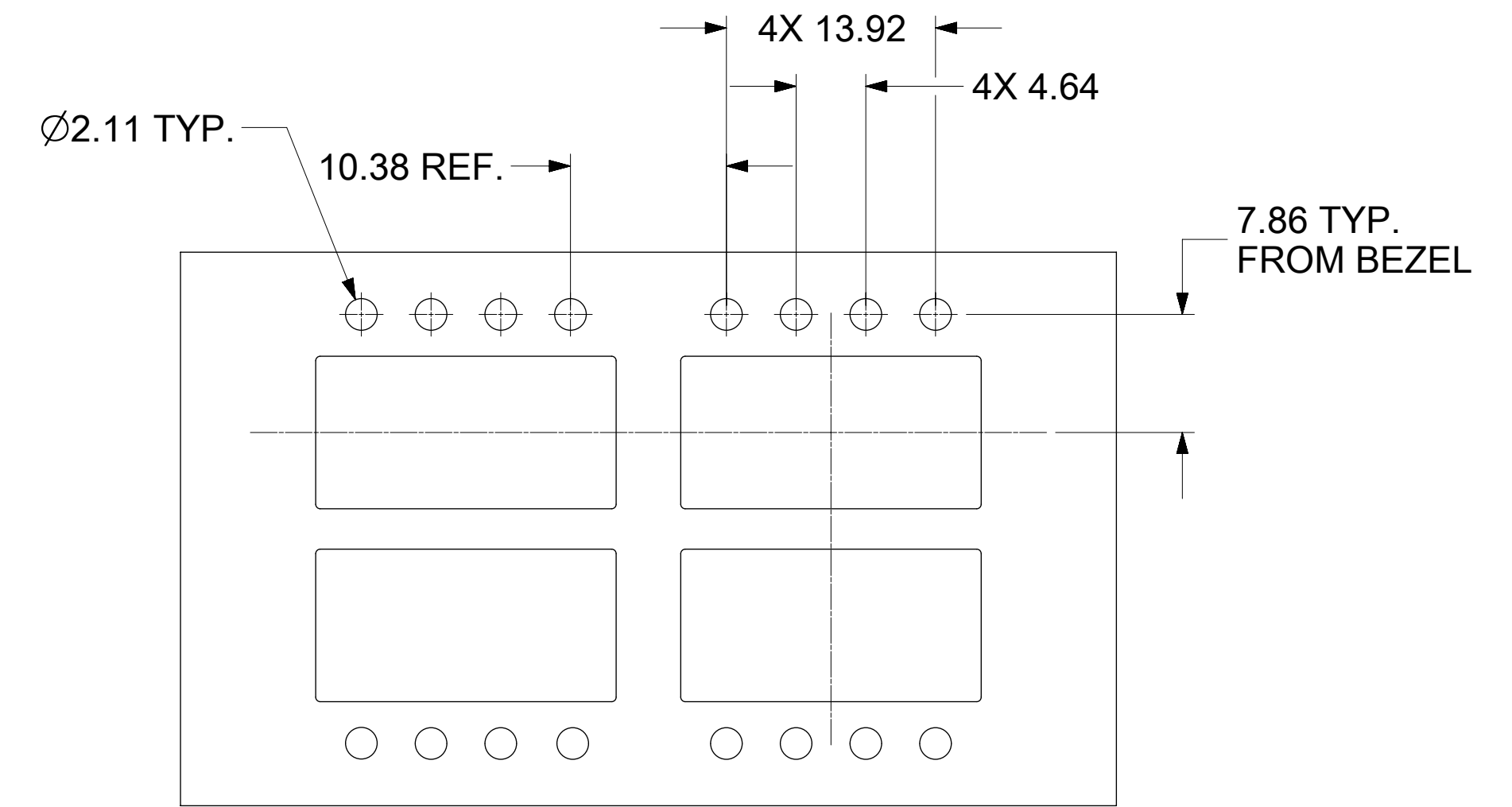
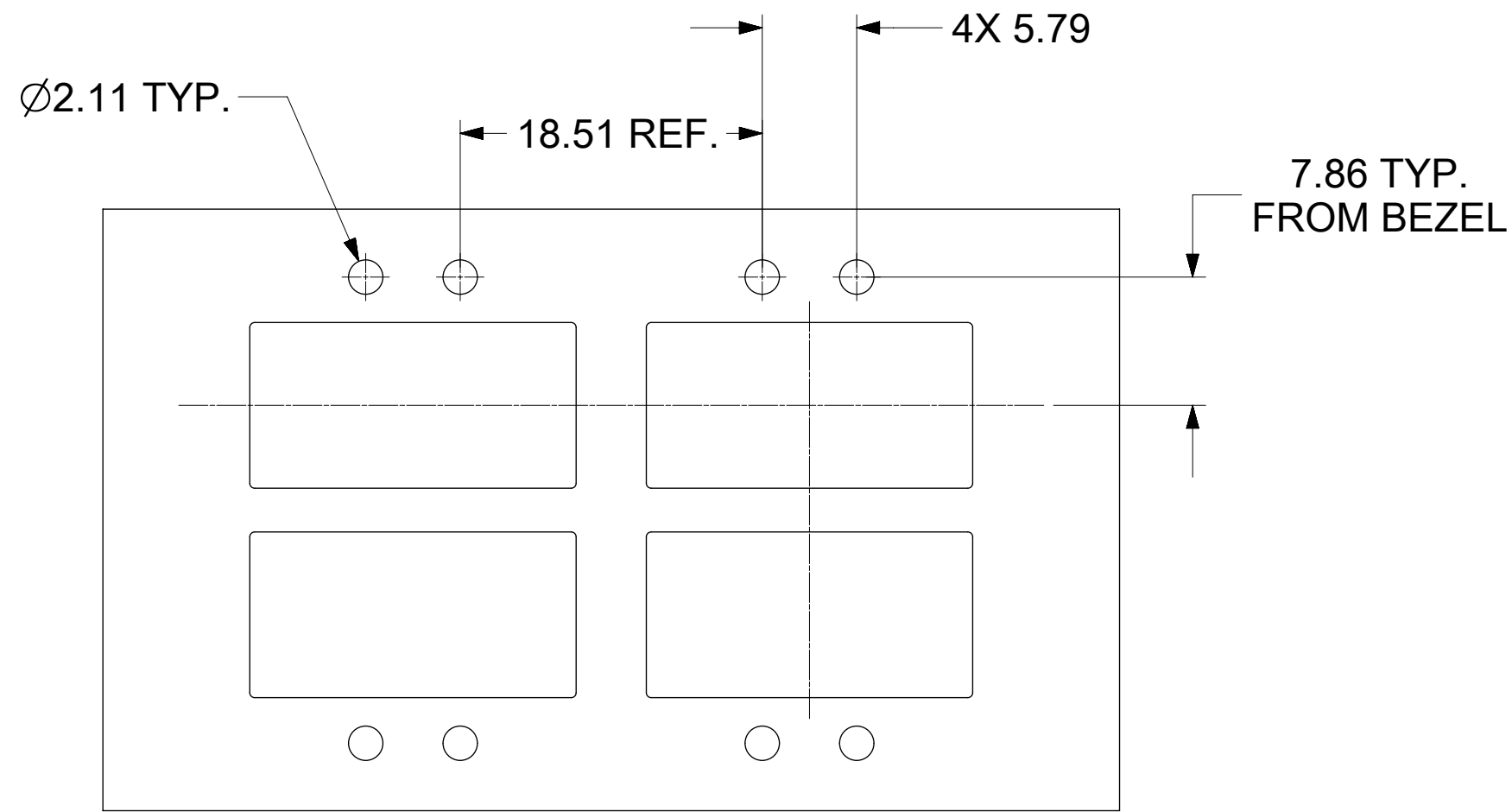
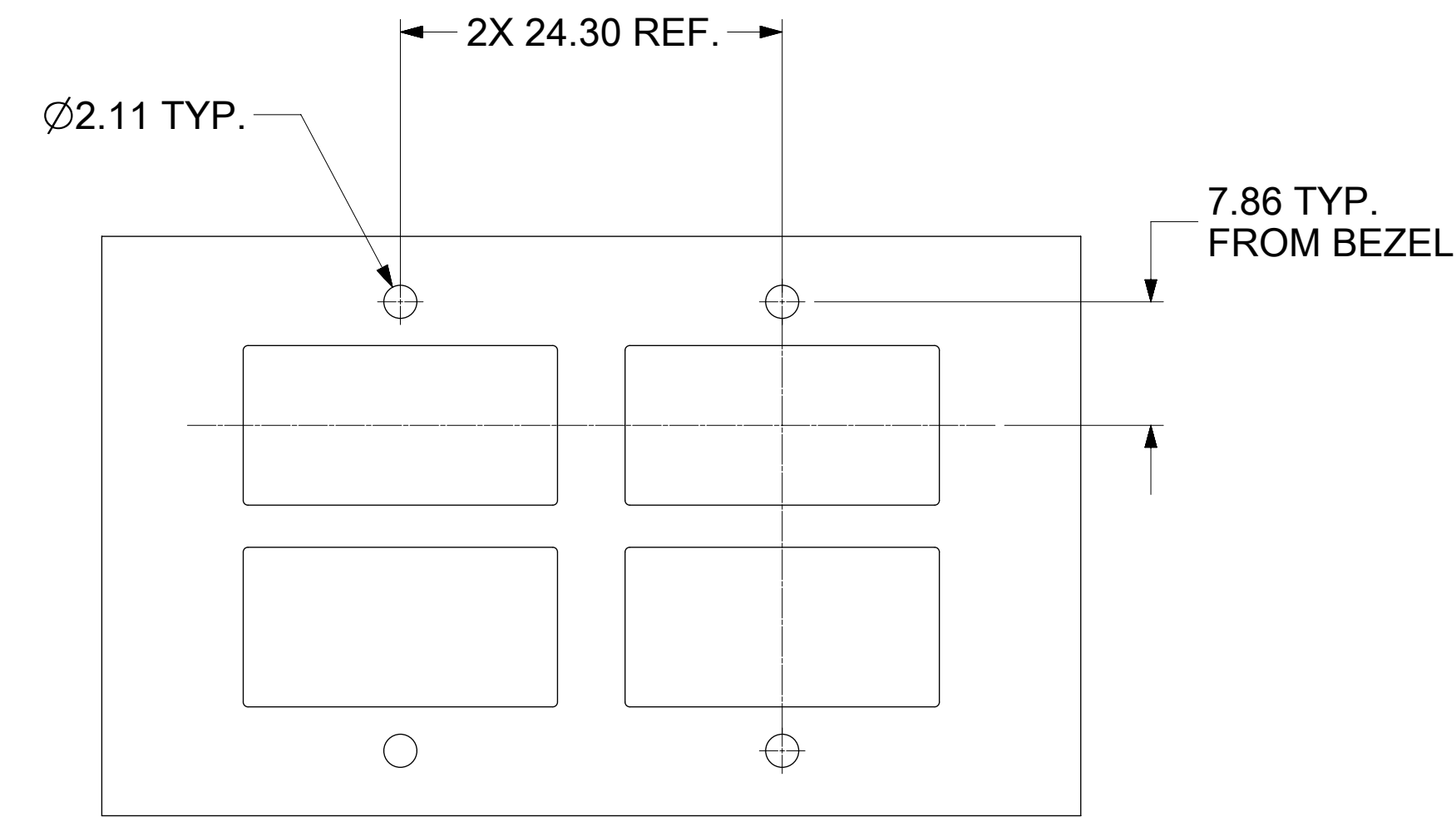

NOTE:
1. PCB THICKNESS VARIATION MUST BE CONSIDERED WHEN DETERMINING BEZEL OPENING, SIZE, AND LOCATION.

THIS DRAWING CONTAINS INFORMATION THAT IS PROPRIETARY TO MOLEX ELECTRONIC TECHNOLOGIES, LLC AND SHOULD NOT BE USED WITHOUT WRITTEN PERMISSION											
DIMENSION UNITS		SCALE		CURRENT REV DESC:						molex	
mm		2.5:1									
GENERAL TOLERANCES (UNLESS SPECIFIED)				EC NO: 712623						DOCUMENT NUMBER	
ANGULAR TOL ± 1.0°				DRWN: PKH 2022/05/27						747503022	
4 PLACES ±				CHK'D: DKUMARG 2022/06/29						DOC TYPE	
3 PLACES ±				APPR: SCHIEN 2022/07/07						PSD	
2 PLACES ± 0.13				INITIAL REVISION:						DOC PART	
1 PLACE ± 0.25				DRWN: PKH 2022/05/27						ASY	
0 PLACES ±				APPR: SCHIEN 2022/07/07						REVISION	
DRAFT WHERE APPLICABLE MUST REMAIN WITHIN DIMENSIONS				THIRD ANGLE PROJECTION		DRAWING		SERIES		CUSTOMER	
						D-SIZE		74750		SEE SHEET 4	
										SHEET NUMBER	
										8 OF 9	

REV	DATE	DESCRIPTION
A	2022/06/25	INITIAL RELEASE

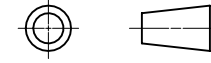
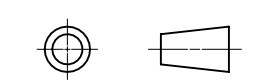
THIS DRAWING CONTAINS INFORMATION THAT IS PROPRIETARY TO MOLEX ELECTRONIC TECHNOLOGIES, LLC AND SHOULD NOT BE USED WITHOUT WRITTEN PERMISSION										
DIMENSION UNITS	SCALE	CURRENT REV DESC:								
mm	1:1									
GENERAL TOLERANCES (UNLESS SPECIFIED)		EC NO: 712623				QSFP+ 1X1 CAGE ASSEMBLY W / ELASTOMERIC GASKET, SUS INNER SPRING FINGER (ROUND & SQUARE)				
ANGULAR TOL ± 1.0°		DRWN: PKH 2022/05/27								
4 PLACES ±		CHK'D: DKUMARG 2022/06/29				PRODUCT CUSTOMER DRAWING				
3 PLACES ±		APPR: SCHIEN 2022/07/07								
2 PLACES ± 0.13		INITIAL REVISION:				DOCUMENT NUMBER		DOC TYPE	DOC PART	REVISION
1 PLACE ± 0.25		DRWN: PKH 2022/05/27				747503022		PSD	ASY	A
0 PLACES ±		APPR: SCHIEN 2022/07/07				SEE SHEET 4		CUSTOMER		SHEET NUMBER
DRAFT WHERE APPLICABLE MUST REMAIN WITHIN DIMENSIONS		THIRD ANGLE PROJECTION	DRAWING	SERIES	MATERIAL NUMBER		CUSTOMER		SHEET NUMBER	
			D-SIZE	74750					9 OF 9	

DOCUMENT STATUS	P1	RELEASE DATE	2022/07/07	13:29:38
-----------------	----	--------------	------------	----------