

TPS658xxEVM Integrated Single-Cell, Lithium-Ion Battery- and Power-Management IC With I2C, LED Drives, Two Synchronous Buck, Boost, and Multiple LDOs

This user's guide is an easy-to-use document that describes the equipment, hardware, software, setup, and a step-by-step procedure to evaluate the features of the TPS65800/810/820/825. The power IC is designed to handle 2 A of input current from the adaptor and up to a 3.5-A discharge from the battery. The charger algorithm is designed to charge a single-cell, Li-ion or Li-polymer battery. The buck, boost, and LDO supplies typically run off of the OUT (system) pin which is available on the IC and is powered from the AC, USB, or battery.

Contents

1	TPS65800/810/820/825 Charger and Power-Management Evaluation Module	2
2	Test Summary	4
3	Getting Started With Evaluation	7
4	Software Feature Description	7
5	Interrupts Software LEDs	17
6	Physical Layouts	18

List of Figures

1	TPS65810EVM Assembly (Similar to Other Versions)	5
2	Equipment and EVM Setup.....	6
3	Charger Section	8
4	Buck and Boost Converters Section	10
5	LDO Section.....	11
6	Analog to Digital Converter Section.....	12
7	PWM Drivers and RGB Drivers Section	14
8	Register Map Section	15
9	GPIO and Mask Control Section	16
10	Board Layout Top Layer	18
11	Board Layout Layer 2	18
12	Board Layout Layer 3	19
13	Board Layout Bottom Layer	19
14	Board Layout Top Assembly Layer	20
15	TPS65800/810EVM Schematic.....	27

List of Tables

1	TPS65800/810/820/825 Outputs and Operational Range	3
2	Performance Specification Summary.....	4
3	HPA129A BOM – TPS65800/810	21
4	HPA184A BOM – TPS65820/825	24

1 TPS65800/810/820/825 Charger and Power-Management Evaluation Module

1.1 Background

The TPS65800/810/820/825 is designed to provide, in a single monolithic IC, flexible charge and system power-path management for a USB-port and AC-adaptor supply; as well as multiple power supply outputs, and a number of value-added circuit options to supply an integrated solution for applications powered by one Li-ion or Li-polymer cell, and requiring multiple voltage rails. The TPS65800/810/820/825 features two highly efficient, step-down converters targeted at providing the core voltage, and peripheral I/O rails in a processor-based system. Both converters enter a low-power mode at light load for maximum efficiency across the widest possible range of load currents. The TPS65800/810/820/825 also integrates a boost-type LED driver, six LDO regulators (five programmable and one fixed), one programmable SIM interface LDO, and an integrated backup block for a battery/rechargeable capacitor. The TPS65800/810/820/825 powers the system while independently charging the battery. This feature reduces the charge and discharge cycles on the battery and allows for proper charge termination and system operation with an absent or defective battery pack. The system can instantaneously turn on using an external power source in the case of a deeply discharged battery pack. The TPS65800/810/820/825 automatically selects the USB port or the AC adaptor as the power source for the system. In the USB configuration, the host can select from the two preset charge rates of 100 mA and 500 mA. The TPS65800/810/820/825 dynamically adjusts the USB charge rate based on system load to stay within the 100-mA or 500-mA charge rates. In the AC-adaptor configuration, an external resistor sets the magnitude of the charge current. The TPS65800/810/820/825 charges the battery in three phases: conditioning, constant current, and constant voltage. Charge is terminated based on minimum current. An internal charge timer provides a backup safety for charge termination. The TPS65800/810/820/825 automatically re-starts the charge if the battery voltage falls below an internal threshold.

The TPS65800/810/820/825 also features an 8-channel (2 external), 10-bit, successive-approximation A/D converter with external trigger capabilities performing single, multiple, and continuous readings; and, returning maximum, minimum, or continuous average values. It also has three programmable general-purpose input output (GPIO) ports. GPIO3 is programmed by default as a trigger for the A/D converter. Two general-purpose PWM drivers and an RGB driver, with programmable current, are also included to provide a highly integrated solution suitable for hand-held and other portable applications.

The TPS65810 is similar to the TPS65800, but has a few changes as follows:

1. The switcher and LDO outputs may have different default values and may be enabled or disabled differently. See [Table 1](#) for differences.
2. The USB boot up is disabled, and ISET2 defaults to high (500-mA current limit level).
3. The charger defaults to off.
4. The TS current bias is turned off, so external biasing is required to create a battery temperature feedback voltage.
5. I2C and read state of GPIO1/2/3.
6. Hot Reset reloads register defaults values and internal pullup resistor on HOT_RESET removed (external resistor is on EVM).
7. I2C machine reads interrupt fix.
8. SM1/2 default enable control changed from GPIO1 and I2C to GPIO1 or I2C.

The TPS65820 is based on the TPS65800 with a few changes. See the application report [SLVA248](#) for the differences among the TPS65800/810/820. The most noticeable difference is on power up, the CE bit is set for battery-only operation. To operate off the AC adapter input, the AC, USB, or the 2.75-A maximum option has to be selected.

Table 1. TPS65800/810/820/825 Outputs and Operational Range⁽¹⁾

Supply	Pin	Type	V _{OUT} (V)	TPS65800/810/820/825		TPS65810		I _o MAX (mA)	Acc %	Steps	Eff %
				V _{OUT} (V)	Default EN/DISabled	V _{OUT} (V)	Default EN/DISabled				
SM1	44	Buck converter	0.6–1.8	1.24	Enabled	1.24	Enabled	600	3	32	90
SM2	49	Buck converter	1.0–3.4	1.8	Enabled	3.32	Enabled	600	3	32	90
SM3	42	Boost output	5–25	Current driven	Disabled	Current driven	Disabled	25	10	256	80
SIM	5	General-purpose LDO	1.8 or 3.0	1.8 ⁽²⁾	Disabled	2.5	Enabled	8	5	2	–
LDO_PM	10	General-purpose LDO (only active if AC or USB present)	3.3	3.3	Enabled	3.3	Enabled	20	5	Fixed	–
LDO0	32	General-purpose LDO disabled by default	3.3	3.3	Disabled	3.3	Disabled	150	3	Fixed	–
LDO1	37	General-purpose LDO	1.25–3.3	2.85	Enabled	1.25	Disabled	150	3	8	–
LDO2	33	General-purpose LDO	1.25–3.3	3.3	Enabled	3.3	Disabled	150	3	8	–
LDO3	28	High PSRR LDO	1.224–4.4	1.25 ⁽³⁾	Enabled	1.5	Disabled	100	3	128	–
LDO4	27	High PSRR LDO	1.224–4.4	2.8	Enabled	1.8	Disabled	100	3	128	–
LDO5	26	High PSRR LDO	1.224–4.4	2.75	Enabled	3.1	Enabled	100	3	128	–
RTC_OUT	4	Linear regulator and charger	3.1	3.1 ⁽⁴⁾	Enabled	1.5	Enabled	8	5	Fixed	–
PWM	34	PWM (adjustable frequency and duty cycle)						150			mA

⁽¹⁾ All output can be controlled and programmed by an I2C-compatible interface. Temperature range is –40°C to 85°C.

⁽²⁾ TPS65825 SIM has two selections, 1.8 and 2.8 VDC. The IC defaults to 2.8 VDC.

⁽³⁾ TPS65825 LDO3 defaults to 1.5 VDC.

⁽⁴⁾ TPS65820/825 RTC_OUT defaults to 2.6 VDC but 3.1 VDC can be selected.

1.2 Performance Specification Summary

This section summarizes the performance specifications of the EVM. [Table 2](#) gives the performance specifications of the EVM.

Table 2. Performance Specification Summary

Specification	Test Conditions	Min	Typ	Max	Units
Input DC Voltage, $V_{(DC)}$		$V_{REG} + 0.5$	5.0	6 ⁽¹⁾	Volts
Battery Charge Current, $I_{O(CHG)}$				1.5 ⁽¹⁾	Amps
Power Dissipation	Pin-Pout			5	Watts

⁽¹⁾ The AC and USB FETs are rated for 18 VDC (all other pens are <6.5 V, see data sheet) but typically this high rating is for transients protection and not for normal operation. The thermal layout on this PCB is optimal and can dissipate up to 5 W with an ambient of 35°C, before the internal junction temperature reaches 125°C. If it is desired to apply DC voltages above 6 V, the charging and load currents may have to be reduced to stay below the 125°C junction temperature. The IC automatically reduces the charging current, with its thermal loop, once the temperature reaches ~12°C. Any further load reduction (on switchers or LDOs) has to be done manually to reduce the junction temperatures. The 125°C threshold is somewhat hard to reach unless the input voltage is high along with high load current, which is not typical.

2 Test Summary

This section shows the test setups used and the features available in evaluating the EVM.

2.1 EQUIPMENT – SM1/SM2, LDO, and Battery Load Boards not Provided

1. Computer running Windows® XP and the attached software.
2. EV2300 HPA002 I2C communication box, USB cable and I2C 4-lead cable (all purchased separately).
3. SM1/2 load board; 10-Ω, 1-W resistor load for each output TB1-1/2 and TB2-1/2. See [Figure 2](#).
4. LDO load board: 33-Ω, 1-W each for J4-LDO0 to A1 GND, J5-LDO1 to A1 GND, J7-LDO2 to A1 GND; 511-Ω, 0.5-W pullup resistors J10-LED_PWM to TP29-SYS_OUT and PWM to TP29-SYS_OUT; 51-Ω, 1-W load resistors for J19-LDO3 to A2 GND, J18-LDO4 to A2 GND, J16-LDO5 to A2 GND. See [Figure 2](#).
5. Battery-simulated load board: Two 5.6-Ω, 20-W and one 10-Ω, 5-W resistors in parallel and connected TB7-1/2 (~2.19 Ω). See [Figure 2](#).
6. Dual power supply, 0-V to 5-V adjustable range, 0-A to 3-A adjustable current limit
7. Scope
8. DMM meter(s).

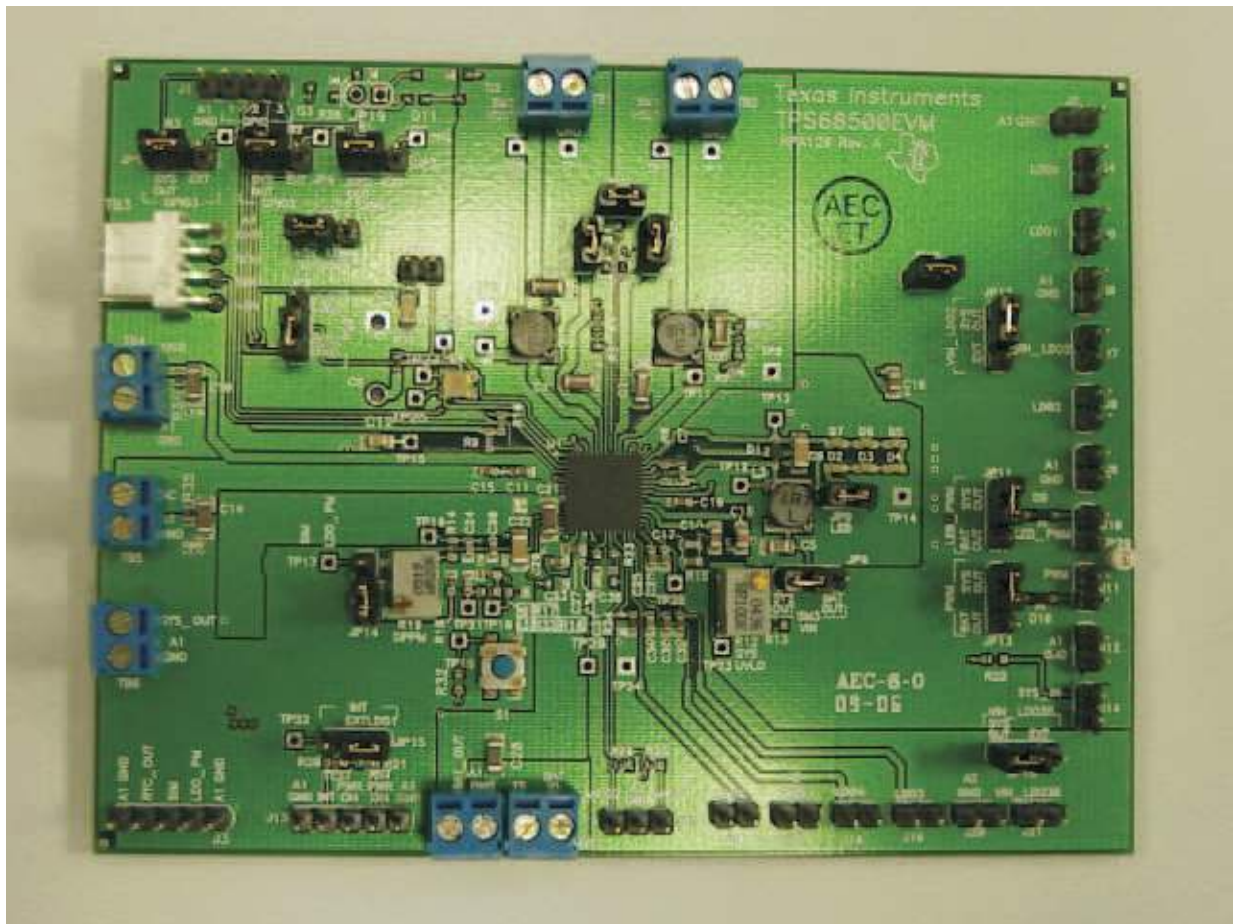

Figure 1. TPS65810EVM Assembly (Similar to Other Versions)

2.2 Equipment Setup

- (a) Verify that the jumpers are in the correct location. JP5/4/3/8/15/12/11/13/6/16 are to be set to SYS_OUT, JP7 to +5V, JP14 to RES, JP15 to LDO1, and JP12/17/18/9; apply jumper across the two pins. See [Figure 1](#).
- (b) Adjust POT R19 until TP16/A1gnd reads 37K, using DMM.
- (c) Adjust POT R12 fully clockwise.
- (d) Connect the loads shown in [Figure 2](#). These are suggested loads, but the user can substitute any load that is within the specification of the IC. The PWM and LED_PWM are open-drain outputs and require a external pullup resistor to OUT (System Power). TB6-1 or TP29 can be used as a source for SYS_OUT.
- (e) Connect the battery-simulated load board shown in [Figure 2](#) below UUT; leave bias supply off. A single-cell Li-ion battery can be used in place of the simulated battery if quick battery voltage adjustment is not needed for evaluation. The battery supply should be the first supply on and the last supply off to avoid putting the BAT output on an unpowered external supply. A power Schottky diode can be placed in series with the positive lead (anode to P/S+) of the battery supply to protect the supply, if necessary.
- (f) Connect USB cable to computer's USB port and the other end to the EV2300 box. Connect the I2C cable between the EV2300 box and the UUT to TB3
- (g) Preset P/S#1 to 5.1 VDC+/-0.1VDC, Current Limit to 2.5A, P/S#2 to 3.5VDC+/-0.1VDC, Current Limit to 2.5A, turn off supplies, connect P/S#1 to TB5-1&2 (+ to AC), and connect P/S#2 to TB7-1&2 (+ to BAT_OUT). See [Figure 2](#).

(h) See the following Software Installation description for directions on installing drivers and application software.

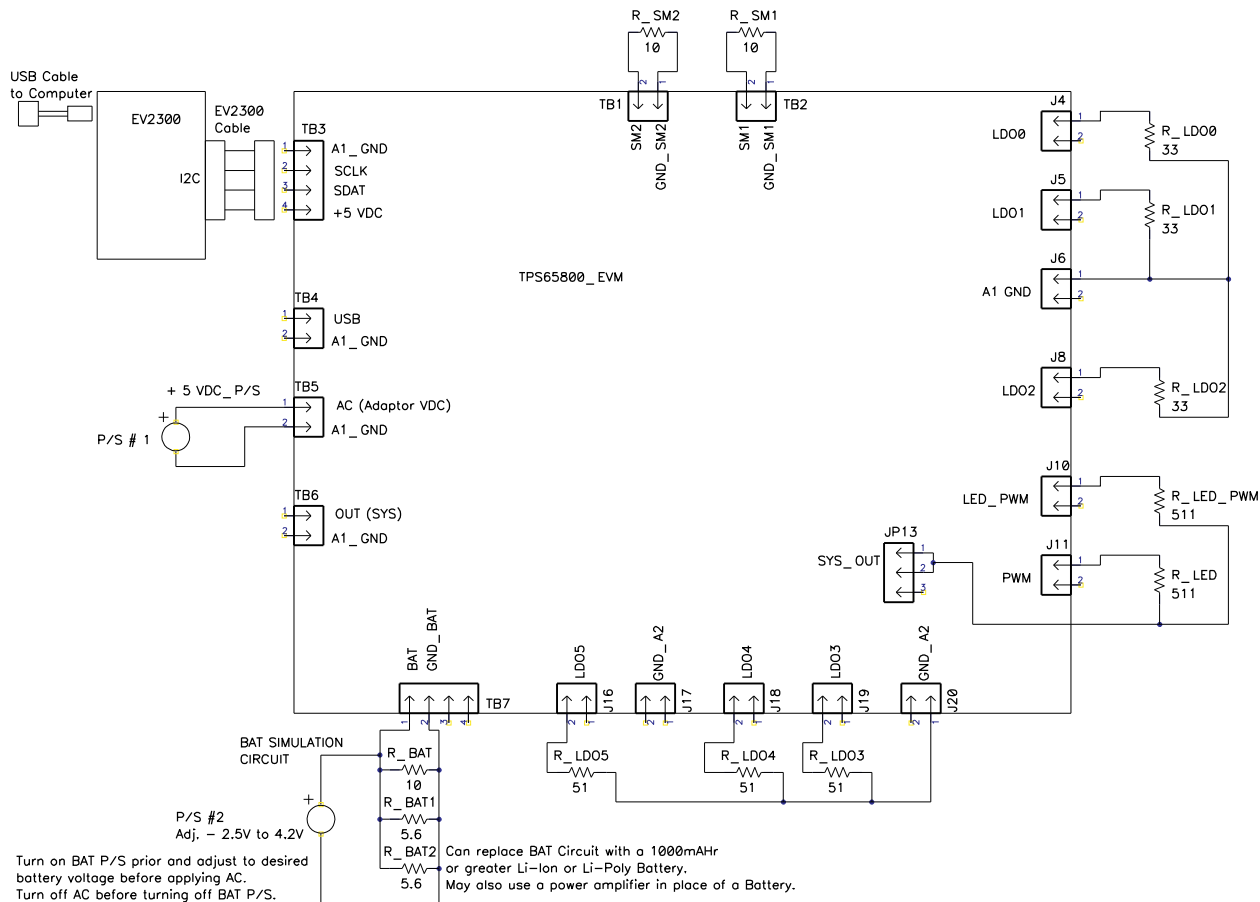

Figure 2. Equipment and EVM Setup

2.3 Software Installation

The following steps install the TPS65800/810 or TPS65820/825 evaluation software:

1. Insert CD ROM into a CD ROM drive.
2. Select the CD ROM drive using **My Computer** or **File Manager**.
3. Select the ReadMeFirst.txt file.
4. Follow the instructions to install USB drivers for EV2300.
5. After installing the USB drivers for EV2300, double-click on the Setup.exe icon that is under the Software/TPS65800, TPS65810, TPS65820, and/or TPS65825 folder.
6. The setup program installs a Windows application group. Follow the on-screen instructions until completion.

2.4 Starting the Program

If the EV2300 is connected to the USB port and the EV2300 drivers installed correctly, then the evaluation software is ready to use. Go to the Getting Started with Evaluation section that follows before starting the application. Close the application if it is open. If the program was installed at its default location, it can be found at Start | Texas Instruments | TPS658xx, where xx is 00, 10, 20, or 25 folder.

3 Getting Started With Evaluation

The evaluation of the TPS65800/810/820/825 is reasonably intuitive when using the software application and the EVM hardware. The user guide is not a step-by-step procedure but an explanation of the result of each software feature. It is highly recommended to read through the data sheet to become familiar with the IC to aid in the evaluation of this EVM. The software code performs several steps per task/feature; reading the data sheet is the best way to understand how to execute these features in the proposed product.

This user's guide was written primarily for the TPS65800 but all versions are similar. For an explanation of the differences among the IC versions, see the TI application report *Differences Between the TPS65800/810/820 PMIC Devices* ([SLVA248](#)). The TPS65800/820/825 are similar with few changes. The TPS65810 is similar to the TPS65800 but has different defaults, sequencing, and enable/disable settings.

3.1 Start-Up

1. Verify that the EVM is set up correctly with the jumpers, loads, and supplies connected as described in the setup procedure.
2. Turn on the P/S #2 (preset to 3.5 VDC across BAT pins, 2.5-A current).
3. Turn on P/S #1 (preset to 5 V, 2.5-A current limit).
4. Launch software under Start | Texas Instruments | TPS65800/810/820/825 EVSW. The application should come up communicating with the EVM.
5. The software is organized under 7 TABs. Click through the tabs to see what features the software controls. Although there is no preferred order to the Evaluation, it may be best to evaluate all the features under one TAB at a time. The ADC tab should be left to last because this section may take longer to evaluate.
6. If a communication error occurs, check setup for any connection problems. Also check J14 (SYS_IN) for a low voltage (<1 V). Close the software and relaunch the application. If the software continues to have a problem with the communication, close the application, turn off P/S#1, then P/S #2, and disconnect the USB cable to the USB connection on the EV2300. Reconnect the USB cable, turn on P/S#2, Turn on P/S#1, and launch the software.
7. When the evaluation is finished, close the application; turn off P/S#1, and then P/S#2.

4 Software Feature Description

4.1 Software Description

Top Menu Description:

File

Start Data Log – Allows the opening of a file so that the logging of a registers' contents can be done in a text file. A Close Data Log option appears in its place when logging is occurring.

Exit – Closes the evaluation software.

I2C

Read and Write Addresses – Permits reading to any desired register. If a register allows it, then it can be written.

Options

Refresh – Updates the screen with valid data obtained from the TPS65800/810/820/825. It is useful for when recovering from a loss of I2C communication.

Logging Options – Allows selecting which registers to log and the time interval between each log line.

Help

About – Gives information of version release of software.

4.2 Charger

The charger section allows the user to monitor and control the charger functions of the TPS65800/810/820/825 (see [Figure 3](#)). The TPS65820/825 IC has a unique feature on power up. After the 150-ms USB boot-up, the PMIC defaults to battery power unless the CE pin is written high prior to the boot-up expiring. The CE pin is at address 9_B0 and is changed via I2C. If the battery is not present and CE is not written high prior to the end of the boot-up, then the system crashes because the BAT pin cannot supply the power. The following controls are available.

- Set Battery Charge Voltage (pulldown window): Default set to 4.2 VDC. To set to 4.36 VDC, select and then confirm yes.
- Set Charge Rate as a percentage of maximum programmed by ISET1 (pulldown window): Select one of four choices 25%, 50%, 75%, or 100% of ISET1 programmed level.
- USB pin input current limit (pulldown window): Select the maximum allowed USB input current level, 100 mA, 500 mA, or 2.75 A (soft internal limit).
- System Power Source (pulldown window): Select *AC*, *USB* or *Battery* or *Battery Only* (AC/USB disable mode).
- Charge Suspend (box): The user can suspend charge by checking the box.

Charger status indications are:

- Power Good – Indicates if voltages at AC or USB inputs are greater than the battery voltage.
- Status – Indicates if the charger is in Pre-charge, Fast Charge, Charge Done or Charge Suspend mode.
- Overvoltage – Indicates if the AC or USB source are within voltage range.
- Dynamic Power Path Management (DPPM) – Powers the system via AC, USB, and/or BAT (see the diagram in [Figure 3](#)).

The information windows are data collected and reported by the ADC such as the battery voltage, the system voltage, the IC temperature, and detection of BATT ID resistor.

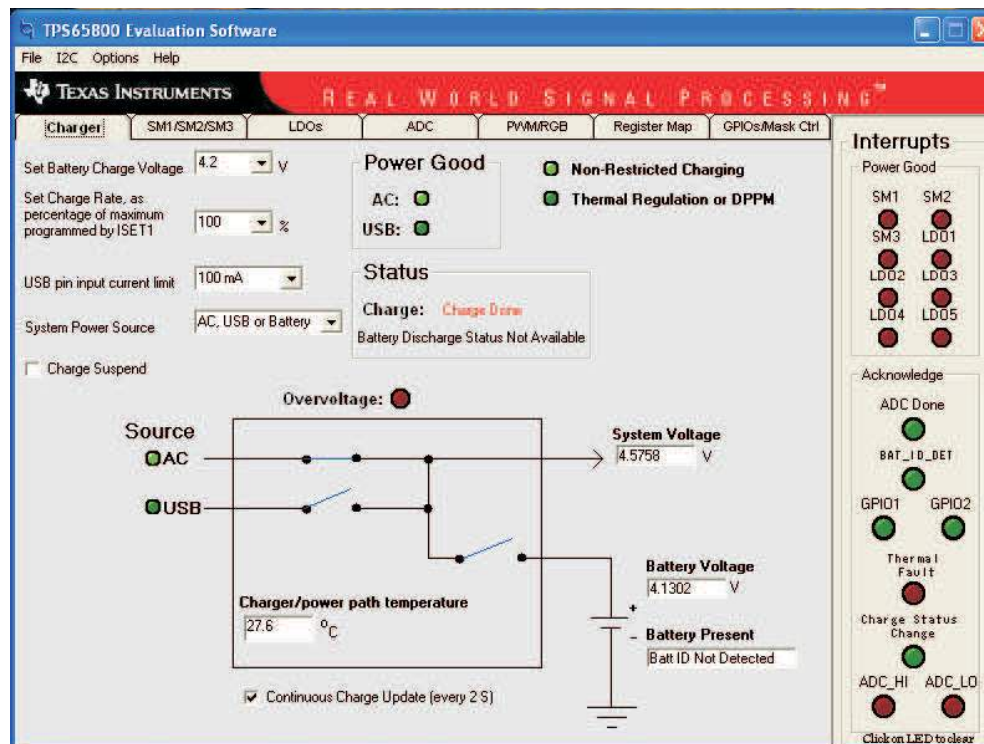

Figure 3. Charger Section

4.3 SM1/SM2/SM3

For the following descriptions of the buck (SM1 and SM2) and boost (SM3) converters, see [Figure 4](#).

SM1 – Synchronous Buck Converter with programmable output: 0.6 VDC-1.8 VDC:

- SM1 Settings: The buck converter can be set in three modes: Normal, Standby and Disabled.
- SM1 Voltage: The voltage can be set by writing the desired voltage value into the text field and then pressing ENTER. The value is then adjusted to the closest value permitted based on the resolution.
- Stby1 Set: The voltage can be set by writing the desired voltage value into the text field and then pressing ENTER. The value is then adjusted to the closest value permitted based on the resolution.
- Slew Rate: The slew rate when going from standby set voltage to normal set voltage can be selected ranging from 0.15 mV/μs up to the maximum slew rate.
- SM1 Mode: The converter can be programmed for PWM ONLY mode or an AUTO mode that switches between PFM and PWM based on the load.
- The PFM mode can be programmed for low ripple or high efficiency.
- SM1 Discharge Switch Enable: When enabled, applies a resistor to the SM1 output when the output is disabled for discharging the output capacitor.
- GPIO Control Enable (box): When enabled, allows the GPIO1 input to enable or disable the SM1/2 Settings. GPIO1 can be selected to be an active at high- or low-logic level.

SM2 – Synchronous Buck Converter with programmable output: 1 VDC and 3.4 VDC

The SM2 descriptions are the same as SM1 (i.e., Replace SM1 with SM2).

SM1/SM2 Common Controls

- GPIO1 Control SM1/SM2 Standby (box): The GPIO1 input signal can control Standby on the SM1/SM2 buck converters if the box is checked, when not using GPIO1 for the enable function.
- Phase Shifting (pulldown window): The buck converters can be phase shifted with respect to each other, in increments of 90°.
- SM1-SM2 Standby: If checked, the SM1/SM2 converters are placed in Standby (does not change SM1 setting selection).

SM3 - Boost Converter

The boost converter is used to drive six white LEDs on the EVM board. To control the intensity of the light emitted, simply enter a value between 0 and 100 and click the **Set** button. The value is adjusted to the nearest available resolution.

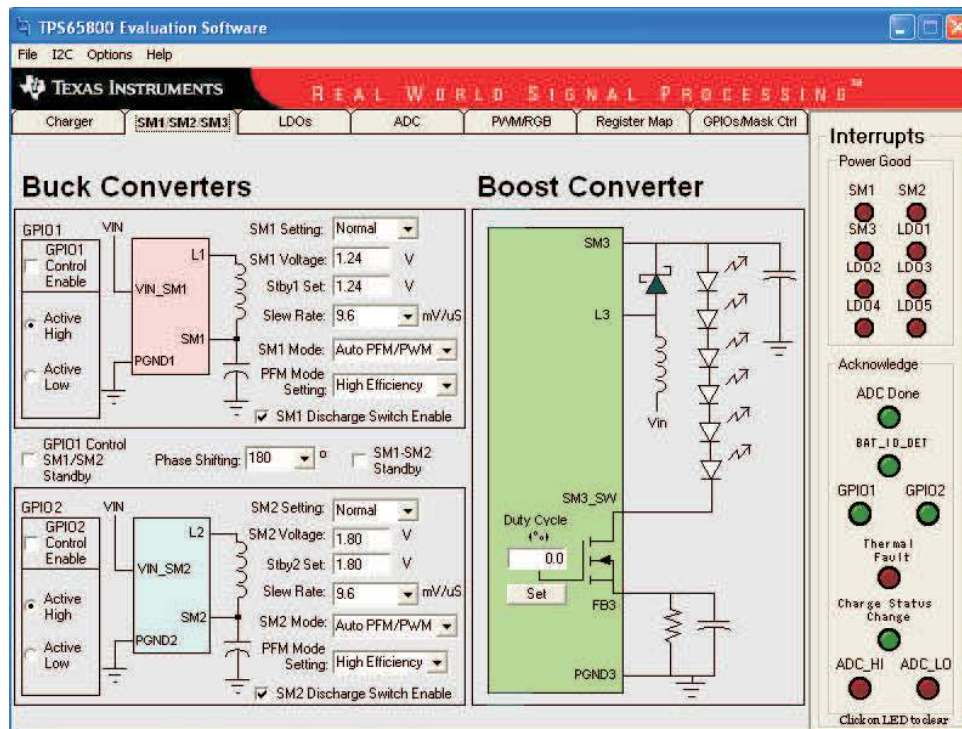

Figure 4. Buck and Boost Converters Section

4.4 LDOs — TPS65800 (See [Table 1](#) for Corresponding Outputs for TPS65810/820/825)

For the following descriptions of the LDO settings, see [Figure 5](#)

LDO 0: Fixed at 3.3 VDC, the output is disabled on power up and can be enabled by checking the box.

RTC: Fixed at 3.1 VDC, the output is enabled on power up and can be disabled by unchecking the box.

SIM: Set to 1.8 VDC, and can be changed to 3 VDC; output is disabled on power up and can be enabled by checking the box.

LDO 1: Default set to 2.85 VDC, and the output can be changed, after power up, via I2C by selecting 1 of 8 settings between 1.25 VDC to 3.3 VDC.

LDO 2: Default set to 3.3 VDC, and the output can be changed, after power up, via I2C by selecting 1 of 8 settings between 1.25 VDC to 3.3 VDC.

LDO 3: Default set to 1.2495 VDC, and the output can be set, after power up, via I2C within the range of 1.22 VDC to 4.46 VDC (128 setting steps).

LDO 4: Default set to 2.754 VDC, and the output can be set, after power up, via I2C within the range of 1.22 VDC to 4.46 VDC (128 setting steps).

LDO 5: Default set to 2.805 VDC, and the output can be set, after power up, via I2C within the range of 1.22 VDC to 4.46 VDC (128 setting steps).

LDO 1–5:

- Output is enabled on power up and comes up to default setting for TPS65800. For TPS65810, outputs are disabled on power up and have to be enabled by I2C for use.
- LDO x Discharge, where x=1-5: If box is checked, a resistor is applied when the output is disabled to discharge the capacitor.
- Enable LDO x, where x=1-5: The output can be disabled by unchecking the box.

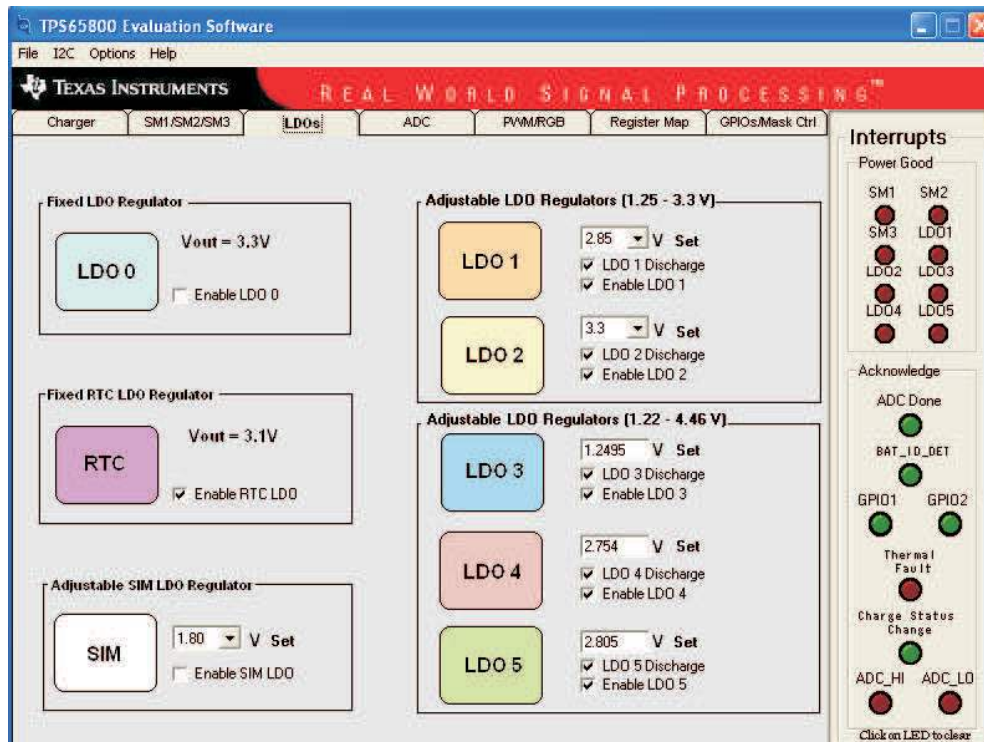

Figure 5. LDO Section

4.5 ADC

This section is used to control the functions of the ADC (see Figure 6).

MODE:

- Repeat/Non-Repeat (bullet): Continuous conversions or a single conversion
- Start Conversion: Click on button to start single or continuous conversions.
- Stop Conversion (shown when Repeat is selected): Stops continuous conversions
- Delay (Pulldown window): Select 1 of 4 delays between conversions.

External Signal Trigger (GPIO3 Input Trigger for Data Conversion)

- External Trigger Enable (box): Check box to use the GPIO3 input as a trigger to initiate conversions; otherwise, initiation can be done manually.
- GPIO3 Input (drop-down window): Select Falling or Rising trigger edge.
- Hold Off Enable (Box): If box is checked, then when GPIO3 input signal goes inactive (opposite of what is selected), the data collection is put on hold and then continues once the GPIO3 input signal goes active again. This allows a certain sample size to be collected over a controlled time frame.

Reference

- Internal Reference of 2.535 VDC, which is maximum scale for Analog 1 through 5. Analog 6 through 8 are scaled up by a factor of 1.854 because the input to the ADC was divided down by this factor. Analog 1 and 2 are the only *user-defined* external inputs.
- External: Maximum value of 3.5 V; the resolution is based on the external value instead of the internal value and is otherwise similar to the operation previously described.

Analog 1/2 Current Set (pulldown window): Select 1 of 4 current sources.

Data Conversions/Control Block/ADC Reading– Continuous and Single

There is a Repeat Mode and a Non-Repeat mode. For best results, use the following steps:

Non-Repeat mode

1. Select *Non-Repeat* mode.

2. Select *Input Channel* – eight choices from pulldown window.
 3. Select *ADC_LO* and *ADC_HI* alarm thresholds – Default settings programmed in EVM software are used unless updated in window.
 4. Select *Sampling mode* – eight choices in pulldown window between 1 and 256.
 5. Select *Wait between conversions* time – 16 choices in pulldown window between 0 ms and 20.48 ms.
 6. Click on *Start Conversions* button.
- Once the ADC is done, it displays the four types of ADC readings available.

Repeat mode

1. Select *Repeat* mode.
2. Select *Delay* time.
3. Select *Input Channel* – eight choices from pulldown window.
4. Select *ADC_LO* and *ADC_HI* alarm thresholds – Default settings programmed in EVM software are used unless updated in window.
5. Select *Sampling mode* – eight choices in pulldown window between 1 and 256.
6. Select *Wait between conversions* time – 16 choices in pulldown window between 0 ms and 20.48 ms.
7. Click on *Start Conversions* button. When the conversion is stopped after a single conversion or an *alarm fault*, there is an *LED Acknowledgment* for either the ADC Done, the *ADC_HI*, or *ADC_LO*.
8. Allow the ADC to perform conversions for the time desired, and then click on the *Stop Conversions* button or if an *ADC_HI* or *ADC_LO* alarms is detected, the conversion stops automatically, indicating a High or Low Alarm and will display the ADC readings. Note that if the data collection is interrupted by an alarm fault, the average value is likely wrong, on multiple data samples, because the unread data points are zero.
9. Click on *Stop Conversions* button when you are ready to read from the ADC. Once the ADC is done with its current conversion, it displays the four ADC readings.

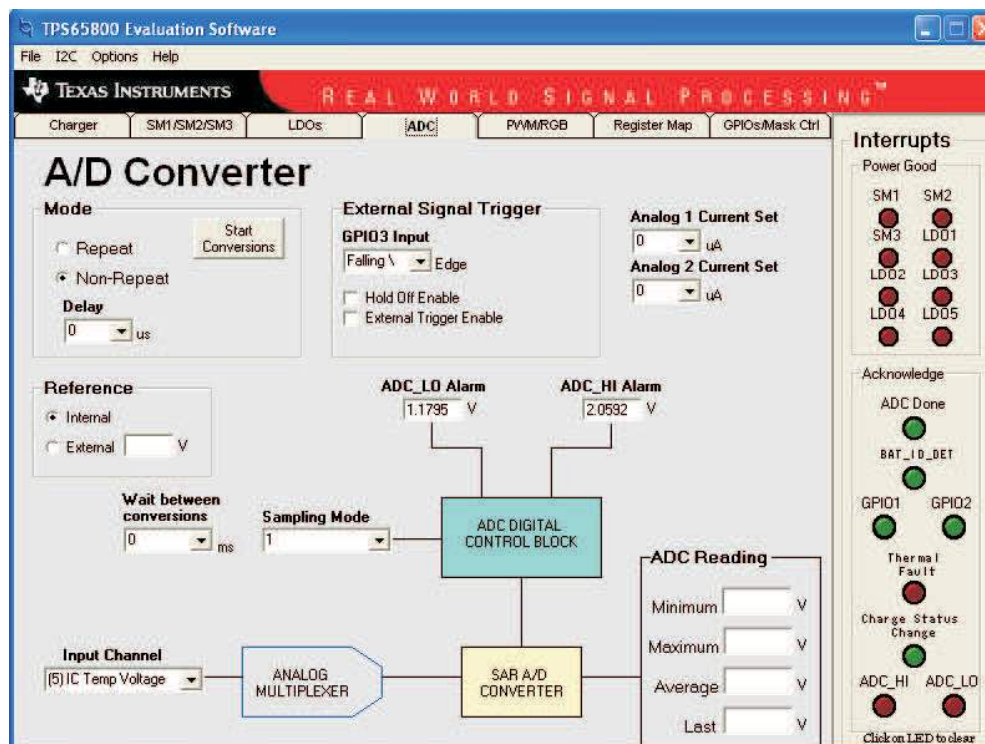

Figure 6. Analog to Digital Converter Section

4.6 PWM/RGB

This section is used to control the PWM and the RGB drivers (see [Figure 7](#)).

PWM Drivers

- Frequency (pulldown window): Select from eight frequencies between 500 Hz and 15,600 Hz
- Duty Cycle (pulldown window): Select from 16 duty cycles between 6.25% and 100%. The PWM is an open drain and requires an external pullup resistor. A 10% duty cycle pulls the signal low 10% of the period T ($t=1/f$).
- Enable (box): Check box to enable signal.

LED PWM Drivers

- Pattern Repeat Frequency: To understand the repeat frequency, set the duty cycle to 0.4% and look at with scope. You should see one pulse per period (122/183 Hz). If the duty cycle is set to 0.8%, there will be two pulses per period and so on, so the repeat pattern is within the selected period ($1/122=8.2$ ms or $1/183=5.5$ ms).
- Duty Cycle (window): You can enter a duty cycle from 0% to 100%. The number entered is updated to the closest value from a list of 256 equal step values.

RGB Driver

- Common Flash Period (pulldown window): Select from 15 values from 1- to 8-second flash period or continuous.
- Common on time (pulldown window): Select from eight values from 0.1-to-0.6 second for LED(s) on time.
- Phase Delay (pulldown window): During the common on time, the color selected is in phase with red; the other color is out of phase with red. You must observe with the scope because this is not typically visible with the eye.
- Open Loop Current (pulldown window): Select from four constant-current levels from 0 mA to 12 mA. You can visualize the change but is hard to see with the scope because the change in voltage drop across the LED due to the change in current, from 4 mA to 12 mA, is small.
- Red/Green/Blue Intensity (windows): You can enter a duty cycle from 0% to 100%. The number entered is updated to the closest value from a list of 32 equal step values.
- RGB Enable (box): Check this box to enable RGB LEDs. Note that the Open Loop Current level and Red/Green/Blue Intensity values have to be something other than zero for the LEDs to light.

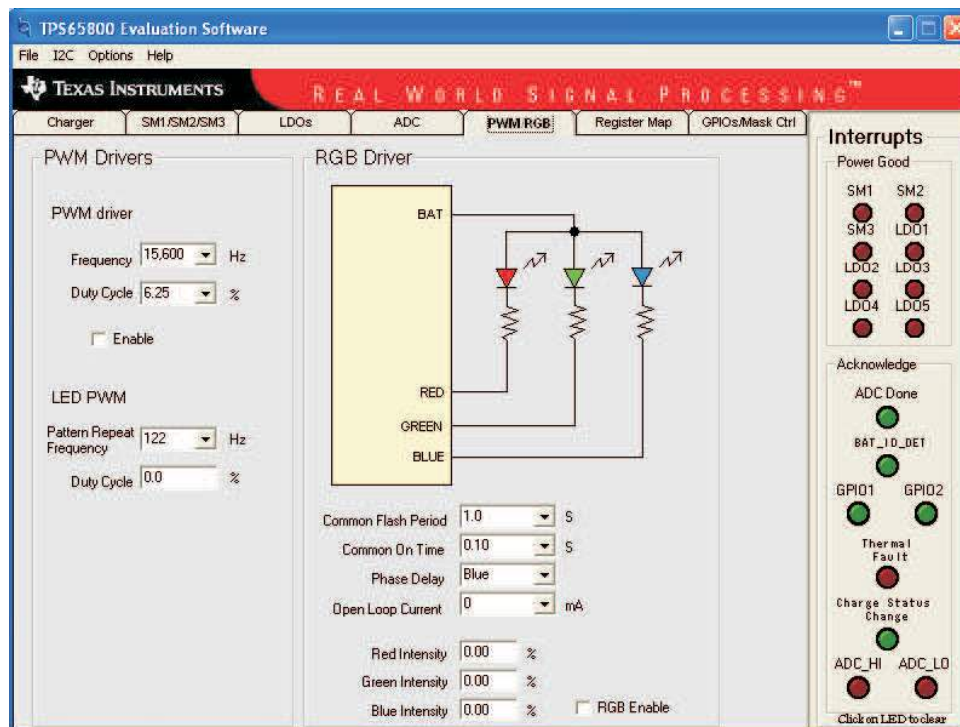

Figure 7. PWM Drivers and RGB Drivers Section

4.7 Register Map

This section contains the full register map of the TPS65800/810/820/825 (see [Figure 8](#)). The scan reads through all the registers. Registers that permit writes can be written by selecting the corresponding *Data* (HEX) grid and writing the desired data in hexadecimal format (i.e., 5F).

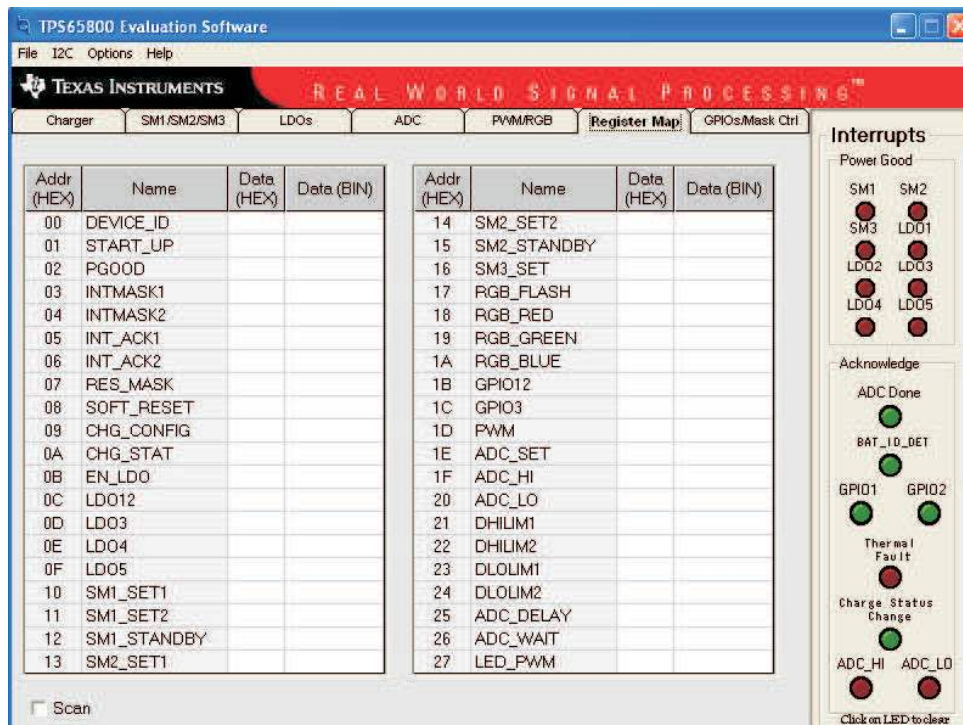

Figure 8. Register Map Section

4.8 GPIOs/Mask CTRL

For the following GPIO/Mask CTRL descriptions, see [Figure 9](#).

GPIO1

Function (pulldown window): Defines if the GPIO1 is an input or output.

If set as an input, the GPIO1 input signal can be set to control the:

1. Enable of SM1 Buck Converter (see SM1/SM2/SM3 tab),
2. Enable Standby of SM1/SM2 Buck Converters (see SM1/SM2/SM3 tab), or
3. The INT output pin and the GPIO1 LED.

If set as an output, the *Output Level* pulldown window appears, and GPIO1 is set according to the *Output Level* pulldown window.

Output Level (pulldown window): Select High or Low to set the level of the GPIO1 output pin (only available if GPIO1 is set as an output).

GPIO1 Interrupt Source (box): Check box if you want a GPIO1 input signal to toggle the INT pin and turn on the Acknowledge LED (stays on momentarily until it is read). Only available if GPIO1 is set as an input.

Interrupt Edge (pulldown window): Choose Rising or Falling Edge for triggering GPIO1 input interrupt (only available if GPIO1 is set as an input).

GPIO2

Function (pulldown window): Defines if the GPIO2 is an input or output

If set as an input, the GPIO2 input signal can be set to control the:

1. Enable of SM2 Buck Converter (see SM1/SM2/SM3 tab), or
2. The INT output pin and the GPIO2 LED.

If set as an output, the *Output Level* pulldown window appears and GPIO2 is set according to the *Output Level* pulldown window.

Output Level (pulldown window): Select High or Low to set the level of the GPIO2 output pin (only available if GPIO2 is set as an output).

GPIO2 Interrupt Source (box): Check box if you want a GPIO2 input signal to toggle the INT pin and turn on the Acknowledge LED (stays on momentarily until it is read). Only available if GPIO2 is set as an input.

Interrupt Edge (pulldown window): Choose Rising or Falling Edge for triggering GPIO2 input interrupt (only available if GPIO2 is set as an input).

GPIO3

Function (pulldown window): Defines if the GPIO3 is an input or output.

If set as an input, the GPIO3 input signal triggers the data conversion routine (see SM1/SM2/SM3 tab). If set as an output, the *Output Level* pulldown window appears and GPIO3 is set according to the *Output Level* pulldown window.

Output Level (pulldown window): Select High or Low to set the level of the GPIO3 output pin (Only available if GPIO3 is set as an output).

Mask INT Interrupts

Sixteen signals are monitored by the ADC for fault conditions, and on detection of a fault, the ADC toggles the INT pin. If the box of a particular signal is checked (masked), the reporting of that fault via the INT pin is disabled.

Sleep Mode Settings

The ADC can be put in sleep mode by a fault (voltage out of range) of any one of the eight power output signals. Check the box(s) for the signal(s) that should put the ADC in sleep mode when in fault status.

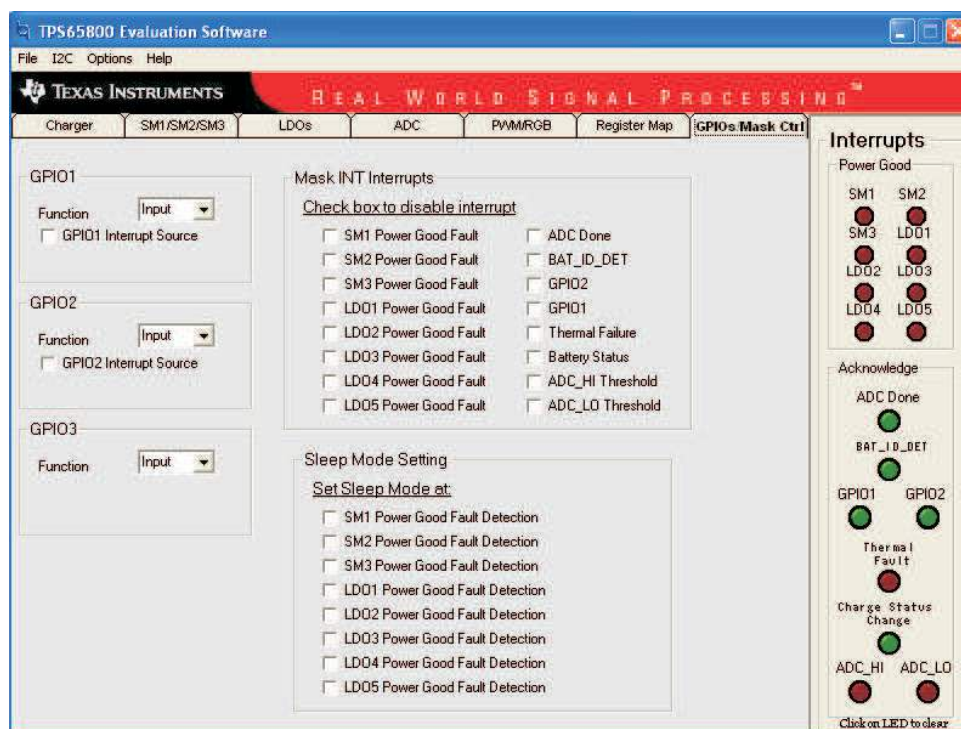

Figure 9. GPIO and Mask Control Section

5 Interrupts Software LEDs

This section describes the values of the bits contained in INT_ACK1 and INT_ACK2 registers. The INT_ACK1 contains the Power Good interrupts and INT_ACK2 contains acknowledgment of interrupts due to events or change of status. Given that the acknowledgments are cleared in the IC once read, the evaluation software manipulates the acknowledgments so that the user can be aware of events that have occurred. So, if an acknowledgment is set in the software, it may not represent the true time value of the corresponding bit.

Power Good – These are set if a power-good interrupt occurs caused by any of the following being out of range:

- SM1, SM2, SM3
- LDO1, LDO2, LDO3, LDO4, and LDO5

Acknowledge – These are set if any of the following events occur:

- **ADC_DONE** – It is set whenever the ADC has completed conversion without violating the ADC_HI or ADC_LO thresholds. To clear the lit LED, click on LED. When operating the software from the ADC section, the software clears the lit LED automatically whenever a conversion is initiated. Given that the event that sets this bit is instantaneous, the software clears the corresponding LED after a user's acknowledgment (click on LED) or to initialize a conversion.
- **BAT_ID_DET** – It is set if an external ID resistor that is in battery pack is detected at ANALOG 1 input.
- **GPIO_1** – If GPIO1 is set as an input, and the GPIO1 INT SOURCE bit is set, then the GPIO_1 Acknowledgment LED toggles for each time that the GPIO1 pin detects a falling edge (in the case that the GPIO is set for falling edge) or a rising edge (in the case that the GPIO is set for rising edge).
- **GPIO_2** – If GPIO2 is set as an input, and the GPIO2 INT SOURCE bit is set, then the GPIO_2 Acknowledgment LED toggles for each time that the GPIO2 pin detects a falling edge (in the case that the GPIO is set for falling edge) or a rising edge (in the case that the GPIO is set for rising edge).
- **Thermal_Fault** – If the IC internal temperature reaches ~155°C, the thermal Fault LED turns on.
- **Charge Status Change** – This bit indicates that the status of the charging has change from one of the following states to another state: precharge, fastcharge, charge pending, and charge done.
- **ADC_HI** – It is set whenever the ADC conversions are terminated due to exceeding ADC_HI thresholds. To clear the lit LED, click on LED. When operating the software from the ADC section, the software clears the LED automatically whenever a conversion is initiated. Given that the event that sets this bit is instantaneous, the software clears the corresponding LED after a user's acknowledgment (click on LED) or to initialize a conversion.
- **ADC_LO** – It is set whenever the ADC conversions are terminated due to measurements captured by the ADC being lower than the ADC_LO threshold. To clear the lit LED, click on LED. When operating the software from the ADC section, the software clears the LED automatically whenever a conversion is initiated. Given that the event that sets this bit is instantaneous, the software clears the corresponding LED after a user's acknowledgment (click on LED) or to initialize a conversion.

6 Physical Layouts

This section contains the board layout, assembly drawings for the EVM, bill of materials, and the schematics. Only the TPS65800/810EVM layout is shown. The TPS65820/825 is identical except for the reduced package size of the TPS65820/825 IC.

6.1 Board Layouts

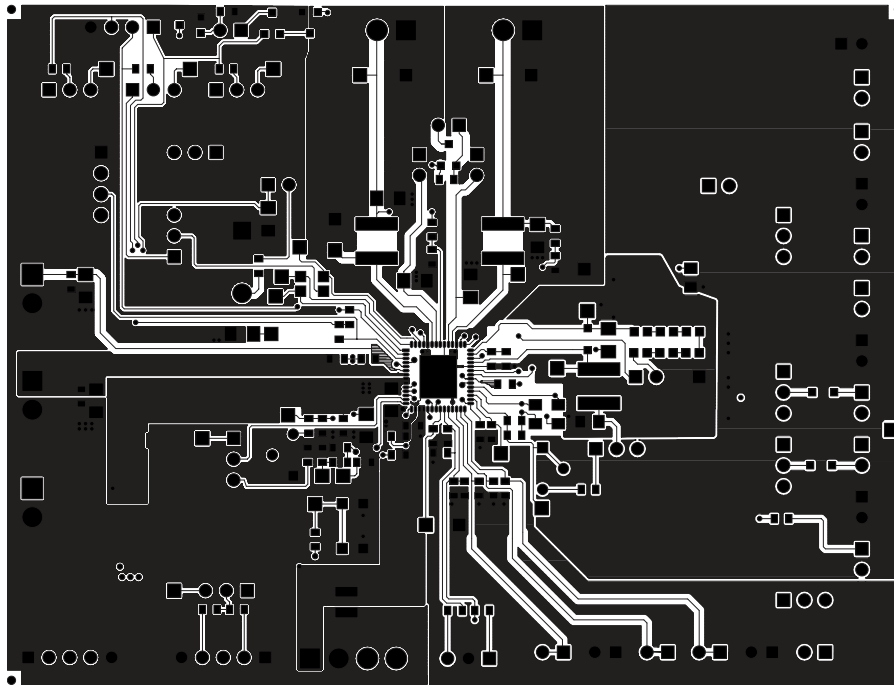

Figure 10. Board Layout Top Layer

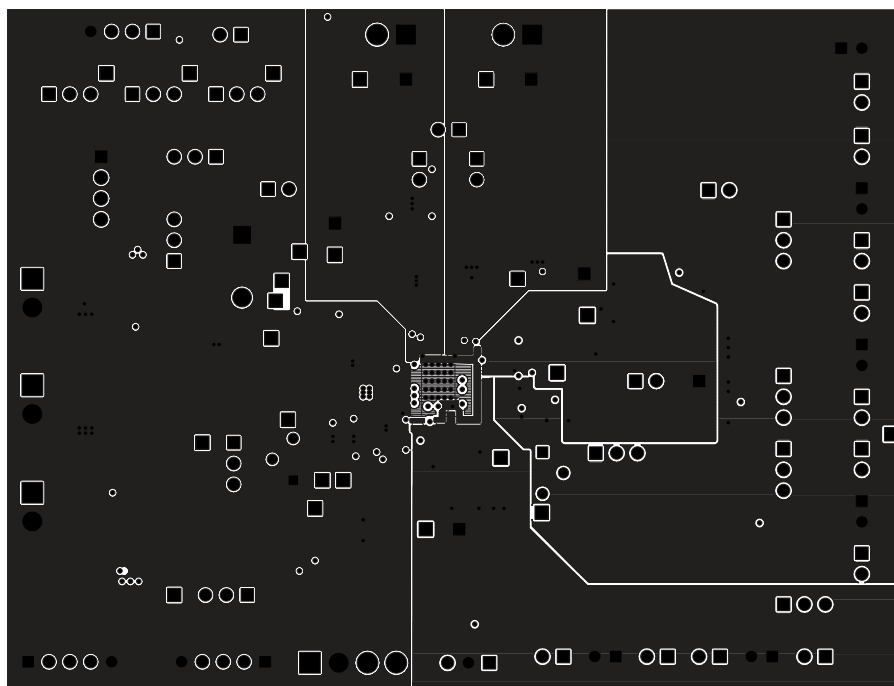

Figure 11. Board Layout Layer 2

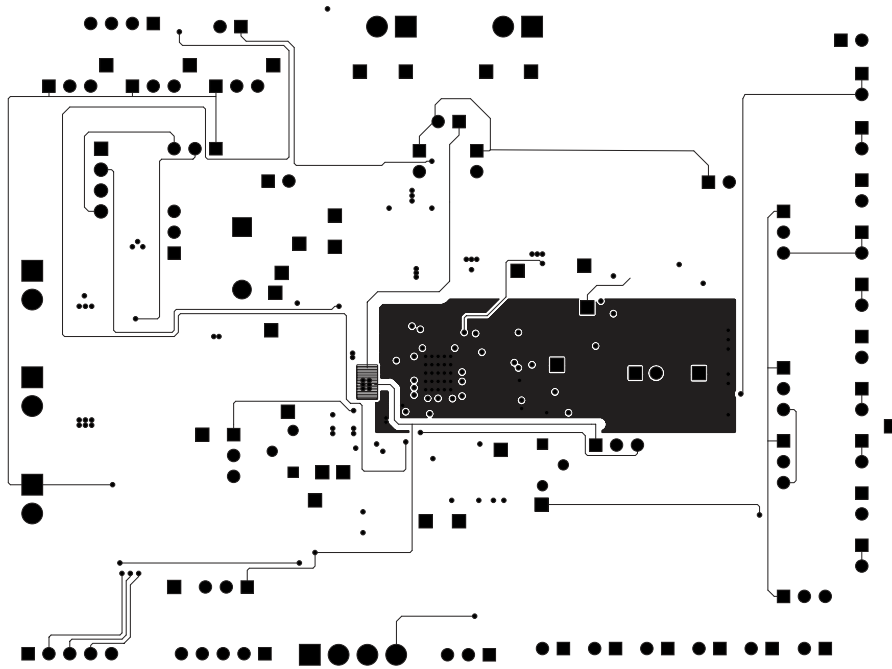

Figure 12. Board Layout Layer 3

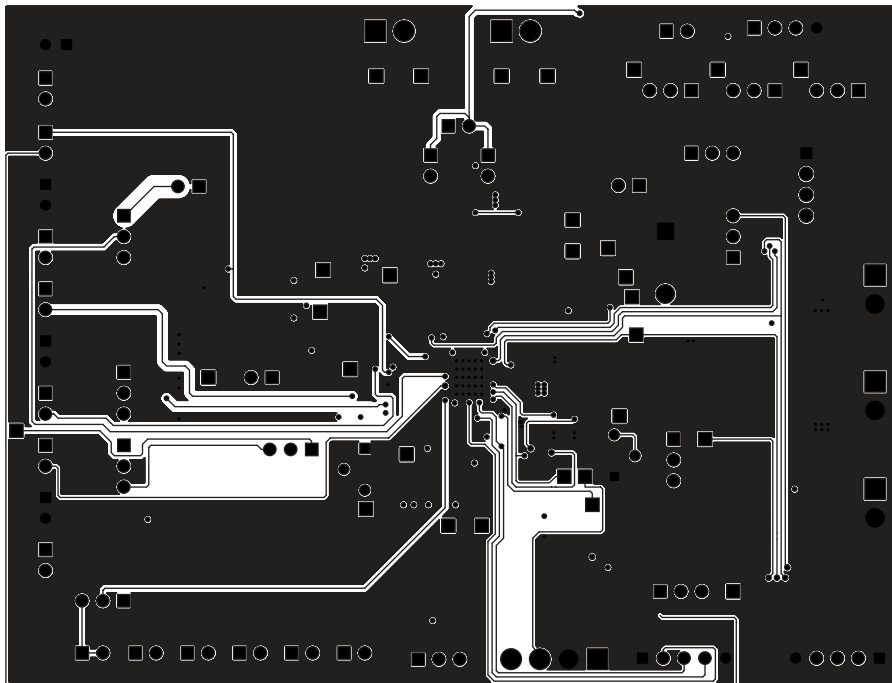

Figure 13. Board Layout Bottom Layer

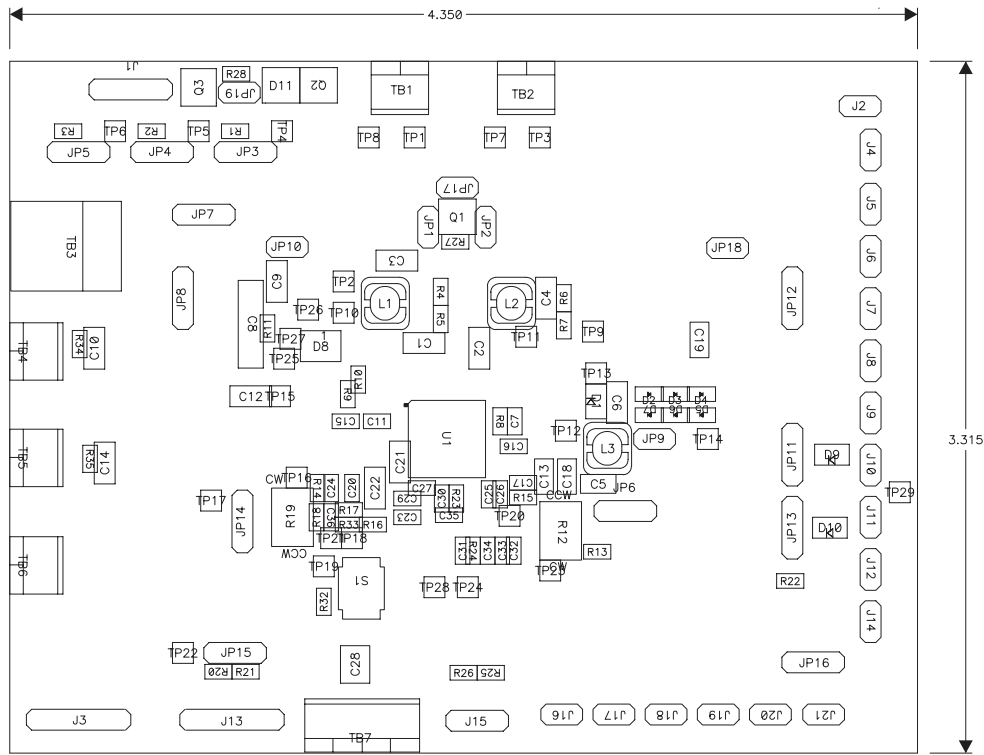

Figure 14. Board Layout Top Assembly Layer

6.2 Bill of Materials

Table 3 and Table 4 list the materials required for the EVM.

Table 3. HPA129A BOM – TPS65800/810

-001 TPS65800	-002 TPS65810						
Count	Count	Ref Des	Value	Description	Size	Part Number	MFR
7	7	C1–C4, C9, C10, C14, C21	10 µF	Capacitor, Ceramic, 10-µF, 16-V, X5R, 20%	1206	ECJ-3YB1E106M	Panasonic
3	3	C11, C15, C27	0.22 µF	Capacitor, Ceramic, 0.22-µF, 16-V, X7R, 10%	0603	C1608X7R1C224K	TDK
3	3	C13, C18, C19	4.7 µF	Capacitor, Ceramic, 10V, X5R, 10%	0805	C0805C475K8PACTU	Kemel
2	2	C16, C25	1 µF	Capacitor, Ceramic, 1-µF, 16-V, X7R, 10%	0603	C1608X7R1C105K	TDK
3	3	C17, C24, C36	1 nF	Capacitor, Ceramic, 1-nF, 5-V, X7R, 10%	0603	C0603C102J5GACTU	Kemmet
1	1	C20	0.1 µF	Capacitor, Ceramic, 0.1 µF, 50-V, X7R, 10%	0603	C1608X7R1H104K	TDK
1	1	C22	1 µF	Capacitor, Ceramic, 16-V, X5R, 20%	1206	ECJ-3YB1E105M	Panasonic
0	0	C23	0.22 µF	Capacitor, Ceramic, 0.22- µF, 16-V, X7R, 10%	0603	C1608X7R1C224K	TDK
1	1	C26	0.01 µF	Capacitor, Ceramic, 0.01- µF, 50-V, X7R, 10%	0603	C1608X7R1H103K	TDK
1	1	C28	22 µF	Capacitor, Ceramic, 50-V, X5R, 20%	1206	ECJ-DV50J226M	Panasonic
1	1	C29	100 nF	Capacitor, Ceramic, 0.1-µF, 50-V, X7R, 10%	0603	C1608X7R1H104K	TDK
1	1	C30	4.7 µF	Capacitor, Ceramic, 4.7-µF, 6.3-V, X5R, 20%	0603	ECJ-1VB0J475M	Panasonic
0	0	C31, C35	1 nF	Capacitor, Ceramic, 1-nF, 50-V, NPO, 10%	0603	C0603C102J5GACTU	Kemmet
1	1	C12	2.2 µF	Capacitor, Ceramic, 2.2-µF, 6.3-V, X5R, 10%	0805	C0805C225K9PACTU	Kemmet
3	3	C32–C34	2.2 µF	Capacitor, Ceramic, 2.2 µF, 6.3-V, X5R, 20%	0603	C1608X5R0J225M	TDK
1	1	C5	10 µF	Capacitor, Ceramic, 1 µF, 6.3-V, X5R, 10%	0805	C0805C106K9PACTU	Kemmet
2	2	C6, C9	1 µF	Capacitor, Ceramic, 10 µF, 25 V, X7R, 10%	1206	C3216X7R1C105/0.85	TDK
1	1	C7	100 pF	Capacitor, Ceramic, 100-pF, 50-V, NPO, 10%	0603	C0603C101J5GACTU	Kemmet
0	0	C8	SUPER	Capacitor, Through Hole, User's Option		User's Option	Mil-Max
3	3	D1, D9, D10	ZHCS400	Diode, Schottky, 400 mA, 40-V	SOD323	ZHCS400	Zelex
1	0	D11	BAT54A	Diode, Dual Schottky, 300-mA, 30-V	SOT23	BAT54A	ST
6	6	D2–D7	WHITE	Diode, LED, White, 20-mA	0603	160-1720-1-ND	Liteon
1	1	D8	QTLP650D-RGB	Diode, LED, Red, Green, Blue 30-20-20-mA, Common anode	0.118 × 0.134 inch	QTLP650D-RGB	Fairchild
1	1	J1	PTC36SAAN	Header, 4-pin, 100 mil spacing, (36-pin strip)	0.100 × 4	PTC36SAAN	Sullins
1	1	J15	PTC36SAAN	Header, 3-pin, 100 mil spacing, (36-pin strip)	0.100 × 3	PTC36SAAN	
17	17	J2, J4–J12, J14, J16–J21	PTC36SAAN	Header, 2-pin, 100 mil spacing, (36-pin strip)	0.100 × 2	PTC36SAAN	
2	2	J3, J13	PTC36SAAN	Header, 5-pin, 100 mil spacing, (36-pin strip)	0.100 × 5	PTC36SAAN	
6	6	JP1, JP2, JP9, JP10, JP17, JP18	PTC36SAAN	Header, 2-pin, 100 mil spacing, (36-pin strip)	0.100 × 2	PTC36SAAN	Sullins
1	0	JP19	PTC36SAAN	Header, 2-pin, 100 mil spacing, (36-pin strip)	0.100 × 2	PTC36SAAN	Sullins

Table 3. HPA129A BOM – TPS65800/810 (continued)

-001 TPS65800	-002 TPS65810						
Count	Count	Ref Des	Value	Description	Size	Part Number	MFR
12	12	JP3–JP8, JP11–JP16	PTC36SAAN	Header, 3-pin, 100 mil spacing, (36-pin strip)	0.100 × 3	PTC36SAAN	Sullins
2	2	L1, L2	3.3 µH	Inductor, SMT, 3.3 H, 1A, 85 mΩ	0.185 × 0.185	CDRH4D-3R3	Sumida
1	1	L3	4.7 µH	Inductor, SMT, 4.7 H, 0.84A, 125 mΩ	0.185 × 0.185	CDRH4D-4R7	Sumida
1	0	Q1	IRLML6401	MOSFET, P-ch, –12V, –3.4A, 50 mΩ	SOT23	IRLML6401	IR
2	0	Q2, Q3	IRLML2402	MOSFET, N-ch, 20V, 1.2A, 250 mΩ	SOT23	IRLML2402	IR
8	8	R1–R3, R15, R20, R21, R34, R35	100K	Resistor, Chip. 1/16-W, 1%	0603	Std	Std
0	1	R32	100K	Resistor, Chip. 1/16-W, 1%	0603	Std	Std
1	1	R11	300	Resistor, Chip. 1/16-W, 1%	0603	Std	Std
1	1	R12	100K	Potentiometer, 1/4 Cermet, 12-Turn, Top-Adjust	0.25 × 0.17 inch	3266W-104	Bourns
1	1	R13	174K	Resistor, Chip. 1/16-W, 1%	0603	Std	Std
1	1	R14	22.6K	Resistor, Chip. 1/16-W, 1%	0603	Std	Std
2	2	R16, R23	1K	Resistor, Chip. 1/16-W, 1%	0603	Std	Std
2	2	R17, R18	49.9K	Resistor, Chip. 1/16-W, 1%	0603	Std	Std
1	1	R19	20K	Potentiometer, 1/4 Cermet, 12-Turn, Top-Adjust	0.25 × 0.17 inch	3266W-203	Bourns
1	1	R22	22.1K	Resistor, Chip, 22.1kΩ, 1/16-W, 1%	0603	Std	Std
1	1	R24	200K	Resistor, Chip, 1/16-W, 1%	0602	Std	Std
1	0	R27	200K	Resistor, Chip, 1/16-W, 1%	0603	Std	Std
1	0	R28	2Meg	Resistor, Chip, 1/16-W, 1%	0603	Std	Std
5	5	R4, R6, R25, R26, R33	0	Resistor, Chip, 1/16W, 1%	0603	Std	Std
0	0	R5, R7	Optional	Resistor, Chip, 1/16W, 1%	0603	Std	Std
1	1	R8	10	Resistor, Chip, 1/16W, 1%	0603	Std	Std
2	2	R9, R10	2K	Resistor, Chip, 1/16W, 1%	0603	Std	Std
1	1	S1	(Value)	Switch, 1P1T, PB Momentary, 100-mA, SM	0.19 × 0.18"	7914G	Bourns
5	5	TB1, TB2, TB4–TB6	ED1514	Terminal Block, 2-pin, 6-A, 3,5 mm	0.27 × 0.25	ED1514	OST
1	1	TB3	22-05-3041	Header, Friction Lock Ass'y. 4-pin right angle	0.400 × 0.500	22-05-3041	Molex
1	1	TB7	ED1516	Terminal Block, 4-pin, 6-A, 3,5 mm	0.55 × 0.25 inch	ED1516	OST
1	1	TP29	5012	Test Point, 0.032 hole	0.25		None
1	0	U1	TPS65800RTQ	IC, Integrated Handheld Power Solution	QFN-56	TPS65800RTQ	TI
0	1	U1	TPS65810RTQ	IC, Integrated Handheld Power Solution	QFN-56	TPS65810RTQ	TI
17	17	See Note 5		Shunt, 100-mil, Black	0.1	929950-00	3M
1	1	—		PCB, 4 in × 3 in × 0.031 in		HPA129	Any

Table 3. HPA129A BOM – TPS65800/810 (continued)

-001 TPS65800	-002 TPS65810						
Count	Count	Ref Des	Value	Description	Size	Part Number	MFR
1	1	Connector					
	2	J5 mate		Connector, Female, 0.100 Centers		22-01-3047	Molex
	8	N/A		Terminals, Crimp, Tin		08-50-0114	Molex
		N/A		Wire, Insulated 24 Awg, Red, (18 inches) (±3 inches)(USB_5V)		1854-3	Alpha
		N/A		Wire, Insulated 24 Awg, White, (18 inches) (±3 inches) (SCL)		1854-1	Alpha
		N/A		Wire, Insulated 24 Awg, Black, (18 inches) (±3 inches) (GND)		1854-2	Alpha
		N/A		Wire, Insulated 24 Awg, Brown, (18 inches) (±3 inches) (SDA)		1854-7	Alpha
	1	N/A		Heatsink 1"			
<p>Notes: 1. These assemblies are ESD sensitive, ESD precautions shall be observed.</p> <p>2. These assemblies must be clean and free from flux and all contaminants. Use of no clean flux is not acceptable.</p> <p>3. These assemblies must comply with workmanship standards IPC-A-610 Class 2.</p> <p>4. Ref designators marked with an asterisk (**) cannot be substituted. All other components can be substituted with equivalent MFG's components.</p> <p>5. Apply Shunt as follows: JP5/JP15/JP4/JP3/JP8/JP12/JP11/JP13/JP6/JP16 are to be sent to SYS-OUT, JP7 to +5V, JP14 to RES, and JP1/JP2/JP17/JP18/JP9 apply jumper across the two pins.</p>							

Table 4. HPA184A BOM – TPS65820/825

-001 TPS65820	-002 TPS65825						
Count	Count	Ref Des	Value	Description	Size	Part Number	MFR
7	7	C1–C4, C9, C10,C14, C21	10 µF	Capacitor, Ceramic, 10-µF, 16-V, X5R, 20%	1206	ECJ-3YB1E106M	Panasonic
3	3	C11, C15, C27	0.22 µF	Capacitor, Ceramic, 0.22-µF, 16-V, X7R, 10%	0603	C1608X7R1C224K	TDK
3	3	C13, C18, C19	4.7 µF	Capacitor, Ceramic, 10V, X5R, 10%	0805	C0805C475K8PACTU	Kemmet
2	2	C16, C25	1 µF	Capacitor, Ceramic, 1-µF, 16-V, X7R, 10%	0603	C1608X7R1C105K	TDK
3	3	C17, C24, C36	1 nF	Capacitor, Ceramic, 1-nF, 5-V, X7R, 10%	0603	C0603C102J5GACTU	Kemmet
1	1	C20	0.1 µF	Capacitor, Ceramic, 0.1 µF, 50-V, X7R, 10%	0603	C1608X7R1H104K	TDK
1	1	C22	1 µF	Capacitor, Ceramic, 16-V, X5R, 20%	1206	ECJ-3YB1E105M	Panasonic
0	0	C23	0.22 µF	Capacitor, Ceramic, 0.22- µF, 16-V, X7R, 10%	0603	C1608X7R1C224K	TDK
1	1	C26	0.01 µF	Capacitor, Ceramic, 0.01- µF, 50-V, X7R, 10%	0603	C1608X7R1H103K	TDK
1	1	C28	22 µF	Capacitor, Ceramic, 50-V, X5R, 20%	1206	ECJ-DV50J226M	Panasonic
1	1	C29	100 nF	Capacitor, Ceramic, 0.1-µF, 50-V, X7R, 10%	0603	C1608X7R1H104K	TDK
1	1	C30	4.7 µF	Capacitor, Ceramic, 4.7-µF, 6.3-V, X5R, 20%	0603	ECJ-1VB0J475M	Panasonic
0	0	C31, C35	1 nF	Capacitor, Ceramic, 1-nF, 50-V, NPO, 10%	0603	C0603C102J5GACTU	Kemmet
1	1	C12	2.2 µF	Capacitor, Ceramic, 2.2-µF, 6.3-V, X5R, 10%	0805	C0805C225K9PACTU	Kemmet
3	3	C32–C34	2.2 µF	Capacitor, Ceramic, 2.2 µF, 6.3-V, X5R, 20%	0603	C1608X5R0J225M	TDK
1	1	C5	10 µF	Capacitor, Ceramic, 10 µF, 6.3-V, X5R, 10%	0805	C0805C106K9PACTU	Kemmet
2	2	C6, C9	1 µF	Capacitor, Ceramic, 1 µF, 25 V, X7R, 10%	1206	C3216X7R1C105/0.85	TDK
1	1	C7	100 pF	Capacitor, Ceramic, 100-pF, 50-V, NPO, 10%	0603	C0603C101J5GACTU	Kemmet
0	0	C8	SUPER	Capacitor, Through Hole, User's Option		User's Option	Mil-Max
3	3	D1, D9, D10	ZHCS400	Diode, Schottky, 400 mA, 40-V	SOD323	ZHCS400	Zelex
1	0	D11	BAT54A	Diode, Dual Schottky, 300-mA, 30-V	SOT23	BAT54A	ST
6	6	D2–D7	WHITE	Diode, LED, White, 20-mA	0603	160-1720-1-ND	Liteon
1	1	D8	QTLP650D-RGB	Diode, LED, Red, Green, Blue 30-20-20-mA, Common anode	0.118 × 0.134 inch	QTLP650D-RGB	Fairchild
1	1	J1	PTC36SAAN	Header, 4-pin, 100 mil spacing, (36-pin strip)	0.100 × 4	PTC36SAAN	Sullins
1	1	J15	PTC36SAAN	Header, 3-pin, 100 mil spacing, (36-pin strip)	0.100 × 3	PTC36SAAN	
17	17	J2, J4–J12, J14, J16–J21	PTC36SAAN	Header, 2-pin, 100 mil spacing, (36-pin strip)	0.100 × 2	PTC36SAAN	
2	2	J3, J13	PTC36SAAN	Header, 5-pin, 100 mil spacing, (36-pin strip)	0.100 × 5	PTC36SAAN	
6	6	JP1, JP2, JP9, JP10, JP17, JP18	PTC36SAAN	Header, 2-pin, 100 mil spacing, (36-pin strip)	0.100 × 2	PTC36SAAN	Sullins
1	1	JP19	PTC36SAAN	Header, 2-pin, 100 mil spacing, (36-pin strip)	0.100 × 2	PTC36SAAN	Sullins
12	12	JP3–JP8, JP11–JP16	PTC36SAAN	Header, 3-pin, 100 mil spacing, (36-pin strip)	0.100 × 3	PTC36SAAN	Sullins

Table 4. HPA184A BOM – TPS65820/825 (continued)

-001 TPS65820	-002 TPS65825						
Count	Count	Ref Des	Value	Description	Size	Part Number	MFR
2	2	L1, L2	3.3 µH	Inductor, SMT, 3.3 H, 1A, 85 mΩ	0.185 × 0.185	CDRH4D-3R3	Sumida
1	1	L3	4.7 µH	Inductor, SMT, 4.7 H, 0.84A, 125 mΩ	0.185 × 0.185	CDRH4D-4R7	Sumida
1	0	Q1	IRLML6401	MOSFET, P-ch, -12V,-3.4A, 50 mΩ	SOT23	IRLML6401	IR
2	2	Q2, Q3	IRLML2402	MOSFET, N-ch, 20V,1.2A, 250 mΩ	SOT23	IRLML2402	IR
8	8	R1–R3, R15, R20, R21, R34, R35	100K	Resistor, Chip, 1/16-W, 1%	0603	Std	Std
0	0	R32	100K	Resistor, Chip, 1/16-W, 1%	0603	Std	Std
1	1	R11	300	Resistor, Chip, 1/16-W, 1%	0603	Std	Std
1	1	R12	100K	Potentiometer, 1/4 Cermet, 12-Turn, Top-Adjust	0.25 × 0.17 inch	3266W-104	Bourns
1	1	R13	174K	Resistor, Chip, 1/16-W, 1%	0603	Std	Std
1	1	R14	22.6K	Resistor, Chip, 1/16-W, 1%	0603	Std	Std
2	2	R16, R23	1K	Resistor, Chip, 1/16-W, 1%	0603	Std	Std
2	2	R17, R18	49.9K	Resistor, Chip, 1/16-W, 1%	0603	Std	Std
1	1	R19	20K	Potentiometer, 1/4 Cermet, 12-Turn, Top-Adjust	0.25 × 0.17 inch	3266W-203	Bourns
1	1	R22	22.1K	Resistor, Chip, 22.1kΩ, 1/16-W, 1%	0603	Std	Std
1	1	R24	200K	Resistor, Chip, 1/16-W, 1%	0602	Std	Std
1	1	R27	200K	Resistor, Chip, 1/16-W, 1%	0603	Std	Std
1	1	R28	2Meg	Resistor, Chip, 1/16-W, 1%	0603	Std	Std
5	5	R4, R6, R25, R26, R33	0	Resistor, Chip, 1/16W, 1%	0603	Std	Std
0	0	R5, R7	Optional	Resistor, Chip, 1/16W, 1%	0603	Std	Std
1	1	R8	10	Resistor, Chip, 1/16W, 1%	0603	Std	Std
2	2	R9, R10	2K	Resistor, Chip, 1/16W, 1%	0603	Std	Std
1	1	S1	(Value)	Switch, 1P1T, PB Momentary, 100-mA, SM	0.19 × 0.18"	7914G	Bourns
5	5	TB1, TB2, TB4–TB6	ED1514	Terminal Block, 2-pin, 6-A, 3,5 mm	0.27 × 0.25	ED1514	OST
1	1	TB3	22-05-3041	Header, Friction Lock Ass'y. 4-pin right angle	0.400 × 0.500	22-05-3041	Molex
1	1	TB7	ED1516	Terminal Block, 4-pin, 6-A, 3,5 mm	0.55 × 0.25 inch	ED1516	OST
1	1	TP29	5012	Test Point, 0.032 hole	0.25		None
1	0	U1	TPS65820RTQ	IC, Integrated Handheld Power Solution	QFN-56	TPS65820RTQ	TI
0	1	U1	TPS65825RTQ	IC, Integrated Handheld Power Solution	QFN-56	TPS65825RTQ	TI
17	17	See Note 5		Shunt, 100-mil, Black	0.1	929950-00	3M
1	1			PCB, 4 in × 3 in × 0.031 in		HPA129	Any
1	1	Connector					
	2	J5 mate		Connector, Female, 0.100 Centers		22-01-3047	Molex
	8	N/A		Terminals, Crimp, Tin		08-50-0114	Molex

Table 4. HPA184A BOM – TPS65820/825 (continued)

-001 TPS65820	-002 TPS65825						
Count	Count	Ref Des	Value	Description	Size	Part Number	MFR
		N/A		Wire, Insulated 24 Awg, Red, (18 inches) (±3 inches)(USB_5V)		1854-3	Alpha
		N/A		Wire, Insulated 24 Awg, White, (18 inches) (±3 inches) (SCL)		1854-1	Alpha
		N/A		Wire, Insulated 24 Awg, Black, (18 inches) (±3 inches) (GND)		1854-2	Alpha
		N/A		Wire, Insulated 24 Awg, Brown, (18 inches) (±3 inches) (SDA)		1854-7	Alpha
	1	N/A		Heatsink 1"			
Notes: 1. These assemblies are ESD sensitive, ESD precautions shall be observed. 2. These assemblies must be clean and free from flux and all contaminants. Use of no clean flux is not acceptable. 3. These assemblies must comply with workmanship standards IPC-A-610 Class 2. 4. Ref designators marked with an asterisk (**) cannot be substituted. All other components can be substituted with equivalent MFG's components. 5. Apply Shunt as follows: JP5/JP4/JP3/JP8/JP15/JP12/JP11/JP13/JP6/JP16 are to be sent to SYS-OUT, JP7 to +5V, JP14 to RES, and JP1/JP2/JP17/JP18/JP9 apply jumper across the two pins.							

EVALUATION BOARD/KIT/MODULE (EVM) ADDITIONAL TERMS

Texas Instruments (TI) provides the enclosed Evaluation Board/Kit/Module (EVM) under the following conditions:

The user assumes all responsibility and liability for proper and safe handling of the goods. Further, the user indemnifies TI from all claims arising from the handling or use of the goods.

Should this evaluation board/kit not meet the specifications indicated in the User's Guide, the board/kit may be returned within 30 days from the date of delivery for a full refund. THE FOREGOING LIMITED WARRANTY IS THE EXCLUSIVE WARRANTY MADE BY SELLER TO BUYER AND IS IN LIEU OF ALL OTHER WARRANTIES, EXPRESSED, IMPLIED, OR STATUTORY, INCLUDING ANY WARRANTY OF MERCHANTABILITY OR FITNESS FOR ANY PARTICULAR PURPOSE. EXCEPT TO THE EXTENT OF THE INDEMNITY SET FORTH ABOVE, NEITHER PARTY SHALL BE LIABLE TO THE OTHER FOR ANY INDIRECT, SPECIAL, INCIDENTAL, OR CONSEQUENTIAL DAMAGES.

Please read the User's Guide and, specifically, the Warnings and Restrictions notice in the User's Guide prior to handling the product. This notice contains important safety information about temperatures and voltages. For additional information on TI's environmental and/or safety programs, please visit www.ti.com/esh or contact TI.

No license is granted under any patent right or other intellectual property right of TI covering or relating to any machine, process, or combination in which such TI products or services might be or are used. TI currently deals with a variety of customers for products, and therefore our arrangement with the user is not exclusive. TI assumes no liability for applications assistance, customer product design, software performance, or infringement of patents or services described herein.

REGULATORY COMPLIANCE INFORMATION

As noted in the EVM User's Guide and/or EVM itself, this EVM and/or accompanying hardware may or may not be subject to the Federal Communications Commission (FCC) and Industry Canada (IC) rules.

For EVMs **not** subject to the above rules, this evaluation board/kit/module is intended for use for ENGINEERING DEVELOPMENT, DEMONSTRATION OR EVALUATION PURPOSES ONLY and is not considered by TI to be a finished end product fit for general consumer use. It generates, uses, and can radiate radio frequency energy and has not been tested for compliance with the limits of computing devices pursuant to part 15 of FCC or ICES-003 rules, which are designed to provide reasonable protection against radio frequency interference. Operation of the equipment may cause interference with radio communications, in which case the user at his own expense will be required to take whatever measures may be required to correct this interference.

General Statement for EVMs including a radio

User Power/Frequency Use Obligations: This radio is intended for development/professional use only in legally allocated frequency and power limits. Any use of radio frequencies and/or power availability of this EVM and its development application(s) must comply with local laws governing radio spectrum allocation and power limits for this evaluation module. It is the user's sole responsibility to only operate this radio in legally acceptable frequency space and within legally mandated power limitations. Any exceptions to this are strictly prohibited and unauthorized by Texas Instruments unless user has obtained appropriate experimental/development licenses from local regulatory authorities, which is responsibility of user including its acceptable authorization.

For EVMs annotated as FCC – FEDERAL COMMUNICATIONS COMMISSION Part 15 Compliant

Caution

This device complies with part 15 of the FCC Rules. Operation is subject to the following two conditions: (1) This device may not cause harmful interference, and (2) this device must accept any interference received, including interference that may cause undesired operation.

Changes or modifications not expressly approved by the party responsible for compliance could void the user's authority to operate the equipment.

FCC Interference Statement for Class A EVM devices

This equipment has been tested and found to comply with the limits for a Class A digital device, pursuant to part 15 of the FCC Rules. These limits are designed to provide reasonable protection against harmful interference when the equipment is operated in a commercial environment. This equipment generates, uses, and can radiate radio frequency energy and, if not installed and used in accordance with the instruction manual, may cause harmful interference to radio communications. Operation of this equipment in a residential area is likely to cause harmful interference in which case the user will be required to correct the interference at his own expense.

FCC Interference Statement for Class B EVM devices

This equipment has been tested and found to comply with the limits for a Class B digital device, pursuant to part 15 of the FCC Rules. These limits are designed to provide reasonable protection against harmful interference in a residential installation. This equipment generates, uses and can radiate radio frequency energy and, if not installed and used in accordance with the instructions, may cause harmful interference to radio communications. However, there is no guarantee that interference will not occur in a particular installation. If this equipment does cause harmful interference to radio or television reception, which can be determined by turning the equipment off and on, the user is encouraged to try to correct the interference by one or more of the following measures:

- Reorient or relocate the receiving antenna.
- Increase the separation between the equipment and receiver.
- Connect the equipment into an outlet on a circuit different from that to which the receiver is connected.
- Consult the dealer or an experienced radio/TV technician for help.

For EVMs annotated as IC – INDUSTRY CANADA Compliant

This Class A or B digital apparatus complies with Canadian ICES-003.

Changes or modifications not expressly approved by the party responsible for compliance could void the user's authority to operate the equipment.

Concerning EVMs including radio transmitters

This device complies with Industry Canada licence-exempt RSS standard(s). Operation is subject to the following two conditions: (1) this device may not cause interference, and (2) this device must accept any interference, including interference that may cause undesired operation of the device.

Concerning EVMs including detachable antennas

Under Industry Canada regulations, this radio transmitter may only operate using an antenna of a type and maximum (or lesser) gain approved for the transmitter by Industry Canada. To reduce potential radio interference to other users, the antenna type and its gain should be so chosen that the equivalent isotropically radiated power (e.i.r.p.) is not more than that necessary for successful communication.

This radio transmitter has been approved by Industry Canada to operate with the antenna types listed in the user guide with the maximum permissible gain and required antenna impedance for each antenna type indicated. Antenna types not included in this list, having a gain greater than the maximum gain indicated for that type, are strictly prohibited for use with this device.

Cet appareil numérique de la classe A ou B est conforme à la norme NMB-003 du Canada.

Les changements ou les modifications pas expressément approuvés par la partie responsable de la conformité ont pu vider l'autorité de l'utilisateur pour actionner l'équipement.

Concernant les EVMs avec appareils radio

Le présent appareil est conforme aux CNR d'Industrie Canada applicables aux appareils radio exempts de licence. L'exploitation est autorisée aux deux conditions suivantes : (1) l'appareil ne doit pas produire de brouillage, et (2) l'utilisateur de l'appareil doit accepter tout brouillage radioélectrique subi, même si le brouillage est susceptible d'en compromettre le fonctionnement.

Concernant les EVMs avec antennes détachables

Conformément à la réglementation d'Industrie Canada, le présent émetteur radio peut fonctionner avec une antenne d'un type et d'un gain maximal (ou inférieur) approuvé pour l'émetteur par Industrie Canada. Dans le but de réduire les risques de brouillage radioélectrique à l'intention des autres utilisateurs, il faut choisir le type d'antenne et son gain de sorte que la puissance isotrope rayonnée équivalente (p.i.r.e.) ne dépasse pas l'intensité nécessaire à l'établissement d'une communication satisfaisante.

Le présent émetteur radio a été approuvé par Industrie Canada pour fonctionner avec les types d'antenne énumérés dans le manuel d'usage et ayant un gain admissible maximal et l'impédance requise pour chaque type d'antenne. Les types d'antenne non inclus dans cette liste, ou dont le gain est supérieur au gain maximal indiqué, sont strictement interdits pour l'exploitation de l'émetteur.

【Important Notice for Users of EVMs for RF Products in Japan】

This development kit is NOT certified as Confirming to Technical Regulations of Radio Law of Japan

If you use this product in Japan, you are required by Radio Law of Japan to follow the instructions below with respect to this product:

1. Use this product in a shielded room or any other test facility as defined in the notification #173 issued by Ministry of Internal Affairs and Communications on March 28, 2006, based on Sub-section 1.1 of Article 6 of the Ministry's Rule for Enforcement of Radio Law of Japan,
2. Use this product only after you obtained the license of Test Radio Station as provided in Radio Law of Japan with respect to this product, or
3. Use of this product only after you obtained the Technical Regulations Conformity Certification as provided in Radio Law of Japan with respect to this product. Also, please do not transfer this product, unless you give the same notice above to the transferee. Please note that if you could not follow the instructions above, you will be subject to penalties of Radio Law of Japan.

Texas Instruments Japan Limited
(address) 24-1, Nishi-Shinjuku 6 chome, Shinjuku-ku, Tokyo, Japan

<http://www.tij.co.jp>

【無線電波を送信する製品の開発キットをお使いになる際の注意事項】

本開発キットは技術基準適合証明を受けておりません。

本製品のご使用に際しては、電波法遵守のため、以下のいずれかの措置を取っていただく必要がありますのでご注意ください。

1. 電波法施行規則第6条第1項第1号に基づく平成18年3月28日総務省告示第173号で定められた電波暗室等の試験設備でご使用いただく。
2. 実験局の免許を取得後ご使用いただく。
3. 技術基準適合証明を取得後ご使用いただく。

なお、本製品は、上記の「ご使用にあたっての注意」を譲渡先、移転先に通知しない限り、譲渡、移転できないものとします。

上記を遵守頂けない場合は、電波法の罰則が適用される可能性があることをご留意ください。

日本テキサス・インスツルメンツ株式会社
東京都新宿区西新宿6丁目24番1号
西新宿三井ビル

<http://www.tij.co.jp>

EVALUATION BOARD/KIT/MODULE (EVM) WARNINGS, RESTRICTIONS AND DISCLAIMERS

For Feasibility Evaluation Only, in Laboratory/Development Environments. Unless otherwise indicated, this EVM is not a finished electrical equipment and not intended for consumer use. It is intended solely for use for preliminary feasibility evaluation in laboratory/development environments by technically qualified electronics experts who are familiar with the dangers and application risks associated with handling electrical mechanical components, systems and subsystems. It should not be used as all or part of a finished end product.

Your Sole Responsibility and Risk. You acknowledge, represent and agree that:

1. You have unique knowledge concerning Federal, State and local regulatory requirements (including but not limited to Food and Drug Administration regulations, if applicable) which relate to your products and which relate to your use (and/or that of your employees, affiliates, contractors or designees) of the EVM for evaluation, testing and other purposes.
2. You have full and exclusive responsibility to assure the safety and compliance of your products with all such laws and other applicable regulatory requirements, and also to assure the safety of any activities to be conducted by you and/or your employees, affiliates, contractors or designees, using the EVM. Further, you are responsible to assure that any interfaces (electronic and/or mechanical) between the EVM and any human body are designed with suitable isolation and means to safely limit accessible leakage currents to minimize the risk of electrical shock hazard.
3. Since the EVM is not a completed product, it may not meet all applicable regulatory and safety compliance standards (such as UL, CSA, VDE, CE, RoHS and WEEE) which may normally be associated with similar items. You assume full responsibility to determine and/or assure compliance with any such standards and related certifications as may be applicable. You will employ reasonable safeguards to ensure that your use of the EVM will not result in any property damage, injury or death, even if the EVM should fail to perform as described or expected.
4. You will take care of proper disposal and recycling of the EVM's electronic components and packing materials.

Certain Instructions. It is important to operate this EVM within TI's recommended specifications and environmental considerations per the user guidelines. Exceeding the specified EVM ratings (including but not limited to input and output voltage, current, power, and environmental ranges) may cause property damage, personal injury or death. If there are questions concerning these ratings please contact a TI field representative prior to connecting interface electronics including input power and intended loads. Any loads applied outside of the specified output range may result in unintended and/or inaccurate operation and/or possible permanent damage to the EVM and/or interface electronics. Please consult the EVM User's Guide prior to connecting any load to the EVM output. If there is uncertainty as to the load specification, please contact a TI field representative. During normal operation, some circuit components may have case temperatures greater than 60°C as long as the input and output are maintained at a normal ambient operating temperature. These components include but are not limited to linear regulators, switching transistors, pass transistors, and current sense resistors which can be identified using the EVM schematic located in the EVM User's Guide. When placing measurement probes near these devices during normal operation, please be aware that these devices may be very warm to the touch. As with all electronic evaluation tools, only qualified personnel knowledgeable in electronic measurement and diagnostics normally found in development environments should use these EVMs.

Agreement to Defend, Indemnify and Hold Harmless. You agree to defend, indemnify and hold TI, its licensors and their representatives harmless from and against any and all claims, damages, losses, expenses, costs and liabilities (collectively, "Claims") arising out of or in connection with any use of the EVM that is not in accordance with the terms of the agreement. This obligation shall apply whether Claims arise under law of tort or contract or any other legal theory, and even if the EVM fails to perform as described or expected.

Safety-Critical or Life-Critical Applications. If you intend to evaluate the components for possible use in safety critical applications (such as life support) where a failure of the TI product would reasonably be expected to cause severe personal injury or death, such as devices which are classified as FDA Class III or similar classification, then you must specifically notify TI of such intent and enter into a separate Assurance and Indemnity Agreement.

Mailing Address: Texas Instruments, Post Office Box 655303, Dallas, Texas 75265
Copyright © 2013, Texas Instruments Incorporated

IMPORTANT NOTICE

Texas Instruments Incorporated and its subsidiaries (TI) reserve the right to make corrections, enhancements, improvements and other changes to its semiconductor products and services per JESD46, latest issue, and to discontinue any product or service per JESD48, latest issue. Buyers should obtain the latest relevant information before placing orders and should verify that such information is current and complete. All semiconductor products (also referred to herein as "components") are sold subject to TI's terms and conditions of sale supplied at the time of order acknowledgment.

TI warrants performance of its components to the specifications applicable at the time of sale, in accordance with the warranty in TI's terms and conditions of sale of semiconductor products. Testing and other quality control techniques are used to the extent TI deems necessary to support this warranty. Except where mandated by applicable law, testing of all parameters of each component is not necessarily performed.

TI assumes no liability for applications assistance or the design of Buyers' products. Buyers are responsible for their products and applications using TI components. To minimize the risks associated with Buyers' products and applications, Buyers should provide adequate design and operating safeguards.

TI does not warrant or represent that any license, either express or implied, is granted under any patent right, copyright, mask work right, or other intellectual property right relating to any combination, machine, or process in which TI components or services are used. Information published by TI regarding third-party products or services does not constitute a license to use such products or services or a warranty or endorsement thereof. Use of such information may require a license from a third party under the patents or other intellectual property of the third party, or a license from TI under the patents or other intellectual property of TI.

Reproduction of significant portions of TI information in TI data books or data sheets is permissible only if reproduction is without alteration and is accompanied by all associated warranties, conditions, limitations, and notices. TI is not responsible or liable for such altered documentation. Information of third parties may be subject to additional restrictions.

Resale of TI components or services with statements different from or beyond the parameters stated by TI for that component or service voids all express and any implied warranties for the associated TI component or service and is an unfair and deceptive business practice. TI is not responsible or liable for any such statements.

Buyer acknowledges and agrees that it is solely responsible for compliance with all legal, regulatory and safety-related requirements concerning its products, and any use of TI components in its applications, notwithstanding any applications-related information or support that may be provided by TI. Buyer represents and agrees that it has all the necessary expertise to create and implement safeguards which anticipate dangerous consequences of failures, monitor failures and their consequences, lessen the likelihood of failures that might cause harm and take appropriate remedial actions. Buyer will fully indemnify TI and its representatives against any damages arising out of the use of any TI components in safety-critical applications.

In some cases, TI components may be promoted specifically to facilitate safety-related applications. With such components, TI's goal is to help enable customers to design and create their own end-product solutions that meet applicable functional safety standards and requirements. Nonetheless, such components are subject to these terms.

No TI components are authorized for use in FDA Class III (or similar life-critical medical equipment) unless authorized officers of the parties have executed a special agreement specifically governing such use.

Only those TI components which TI has specifically designated as military grade or "enhanced plastic" are designed and intended for use in military/aerospace applications or environments. Buyer acknowledges and agrees that any military or aerospace use of TI components which have **not** been so designated is solely at the Buyer's risk, and that Buyer is solely responsible for compliance with all legal and regulatory requirements in connection with such use.

TI has specifically designated certain components as meeting ISO/TS16949 requirements, mainly for automotive use. In any case of use of non-designated products, TI will not be responsible for any failure to meet ISO/TS16949.

Products

Audio	www.ti.com/audio
Amplifiers	amplifier.ti.com
Data Converters	dataconverter.ti.com
DLP® Products	www.dlp.com
DSP	dsp.ti.com
Clocks and Timers	www.ti.com/clocks
Interface	interface.ti.com
Logic	logic.ti.com
Power Mgmt	power.ti.com
Microcontrollers	microcontroller.ti.com
RFID	www.ti-rfid.com
OMAP Applications Processors	www.ti.com/omap
Wireless Connectivity	www.ti.com/wirelessconnectivity

Applications

Automotive and Transportation	www.ti.com/automotive
Communications and Telecom	www.ti.com/communications
Computers and Peripherals	www.ti.com/computers
Consumer Electronics	www.ti.com/consumer-apps
Energy and Lighting	www.ti.com/energy
Industrial	www.ti.com/industrial
Medical	www.ti.com/medical
Security	www.ti.com/security
Space, Avionics and Defense	www.ti.com/space-avionics-defense
Video and Imaging	www.ti.com/video

TI E2E Community

e2e.ti.com