

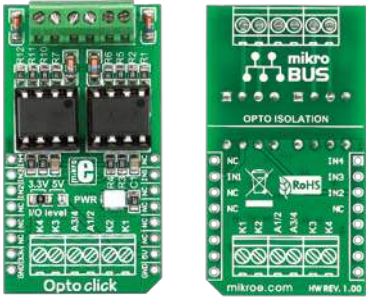

Opto click™

1. Introduction



Opto Click™ is an accessory board in **mikroBUS™** form factor. It's a compact solution for adding electrical isolation between inputs and outputs to your device. It features two DIP **V02630** dual channel, high speed optocoupler modules. Opto Click™ communicates with target board via four **mikroBUS™** lines (INT, CS, RST, AN). The board is designed to use 3.3V and 5V power supply. It has six screw terminals for easy connection and a LED diode (GREEN) that indicates the presence of power supply.

2. Soldering the headers

Before using your click board™, make sure to solder 1x8 male headers to both left and right side of the board. Two 1x8 male headers are included with the board in the package.



1

2



Turn the board upside down so that bottom side is facing you upwards. Place shorter parts of the header pins in both soldering pad locations.

3

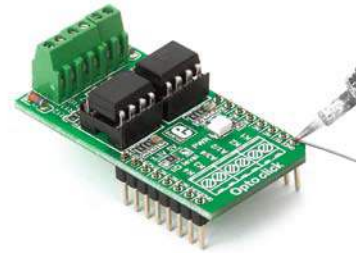

Turn the board upward again. Make sure to align the headers so that they are perpendicular to the board, then solder the pins carefully.

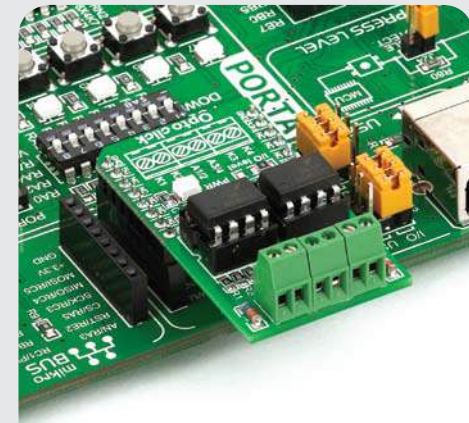

4. Essential features

Opto Click™ with its DIP **V02630** modules results in support for high speed (10 Mbd) between its input and output with galvanic isolation. It has common mode transient immunity of 100 V/μs and low input current capability of 5 mA. All these features make this board ideal for PLC and ATE I/O isolation, high speed A/D and D/A conversion, Digital control power supply, computer peripherals, microprocessor interface and more.

3. Plugging the board in

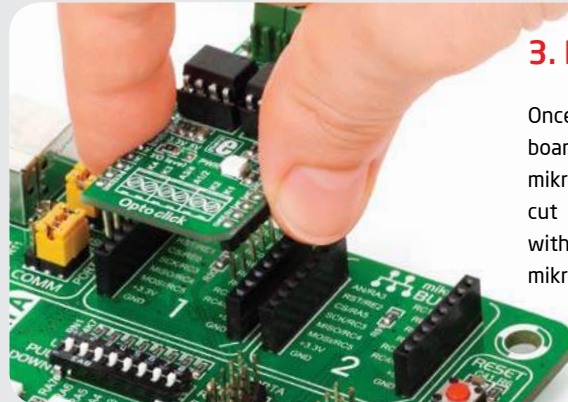

Once you have soldered the headers your board is ready to be placed into desired mikroBUS™ socket. Make sure to align the cut in the lower-right part of the board with the markings on the silkscreen at the mikroBUS™ socket. If all of the pins are aligned correctly, push the board all the way into the socket.

click™
BOARD
www.mikroe.com

Opto click Manual
ver. 1.00



0 100000 020999

5. Opto Click™ Board Schematic

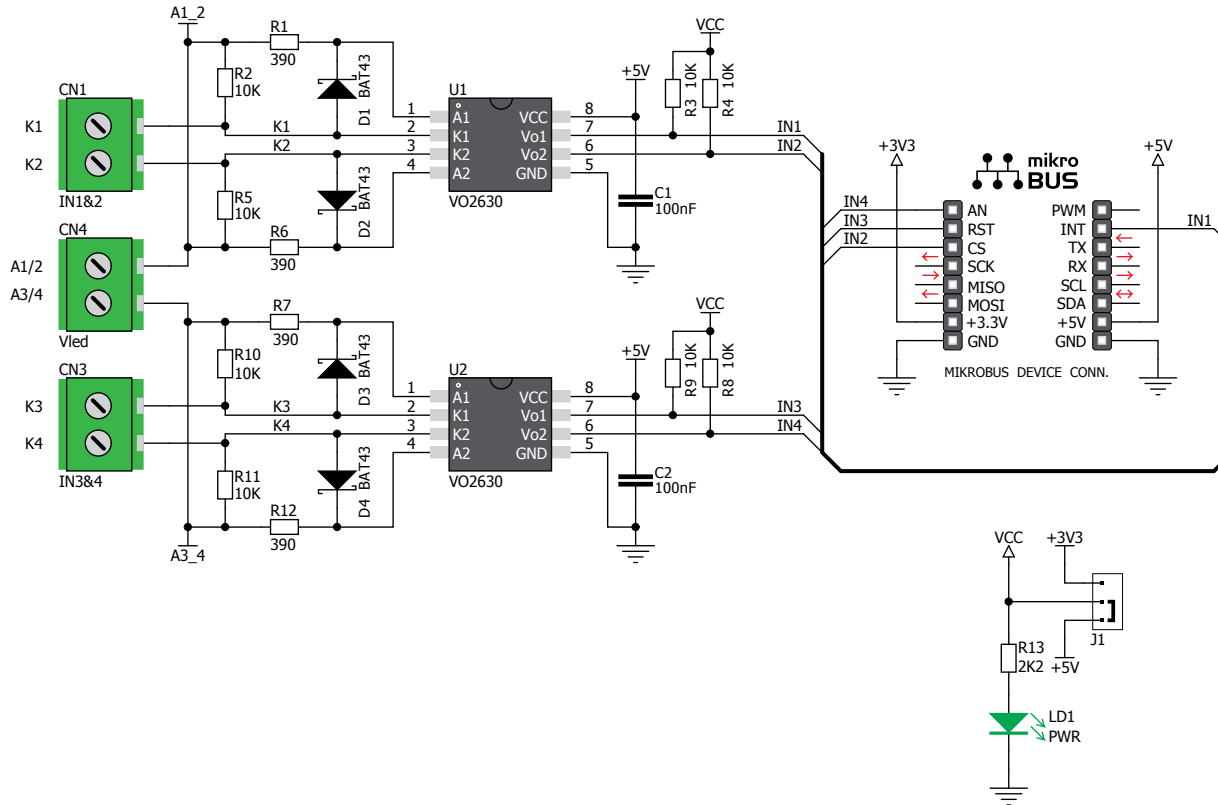

6. SMD Jumper



There is one zero-ohm SMD jumper **J1** which is used to select whether 3.3V or 5V power supply is used. Jumper **J1** is soldered in 3.3V position by default.

7. Code Examples

Once you have done all the necessary preparations, it's time to get your click board up and running. We have provided the examples for mikroC, mikroBasic and mikroPascal compilers on our **Libstock** website. Just download them and you are ready to start.



8. Support

MikroElektronika offers **Free Tech Support** (www.mikroe.com/esupport) until the end of product lifetime, so if something goes wrong, we are ready and willing to help!