

GENERAL DESCRIPTION

The SP7121 LED driver provides a simple solution for a matched current source for any color common cathode LEDs. The common cathode connection allows the user to increase the LED power dissipation by having the cathodes heat sinked to the ground plane of the circuit board. The SP7121 output current value is set by an external resistor. At shutdown mode (EN pin is LOW), the supply current drops to .04 μ A typical.

The SP7121 is available in a small footprint RoHS compliant, lead-free and green/halogen free 6-pin SOT23 packages.

APPLICATIONS

- **Mobile Phones**
- **PDA, DSC, MP3 Players**
- **Handheld Computers**
- **Keypads and Displays Backlight**

FEATURES

- **LED Driver for Common Cathode Parallel Connected LEDs**
- **Ultra Low Dropout Voltage of 300mV @ 25mA**
- **No EMI, no Switching Noise**
- **Integrated Current Matching**
- **PWM Brightness Control**
- **Enable/Shutdown Control**
- **Shutdown Current < 1 μ A**
- **Adjustable Output Current up to 30mA per Channel**
- **RoHS Compliant, Lead Free and Halogen Free SOT23-6 Packages**

TYPICAL APPLICATION DIAGRAM

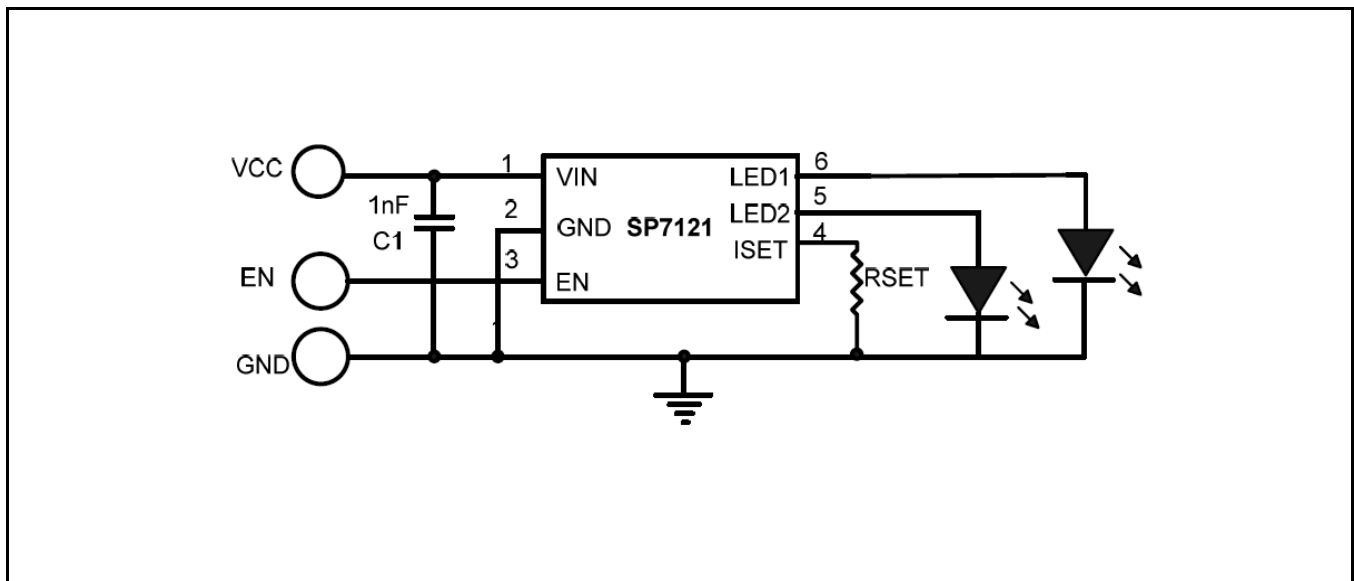

Fig. 1: SP7121 Application Diagram



SP7121

2-Channel Adjustable Low Dropout High Side Linear LED Driver

ABSOLUTE MAXIMUM RATINGS

These are stress ratings only and functional operation of the device at these ratings or any other above those indicated in the operation sections of the specifications below is not implied. Exposure to absolute maximum rating conditions for extended periods of time may affect reliability.

V_{CC} , V_{LED1} , V_{LED2} , EN to GND..... -0.3V to 6.0V
 LED Current I_{LED1} , I_{LED2} 30mA
 Storage Temperature..... -65°C to 150°C
 Junction Temperature 150°C
 Lead Temperature (Soldering, 10 sec) 300°C
 ESD Rating (HBM) Enable and ISET pins.....1.5kV
 ESD Rating (HBM) All other pins.....2.0kV
 ESD Rating (MM - Machine Model)200V

OPERATING RATINGS

Input Voltage Range V_{IN}2.7V to 5.5V
 Operating Temperature Range..... -40°C to 85°C
 Thermal Resistance θ_{JA} 190°C/W

ELECTRICAL SPECIFICATIONS

Specifications with standard type are for an Operating Junction Temperature of $T_A = 25^\circ\text{C}$ only; limits applying over the full Operating Ambient Temperature range are denoted by a “•”. Minimum and Maximum limits are guaranteed through test, design, or statistical correlation. Typical values represent the most likely parametric norm at $T_A = 25^\circ\text{C}$, and are provided for reference purposes only. Unless otherwise indicated, $V_{CC} = 2.7\text{V}$ to 5.5V , ENABLE = V_{CC} , $I_{LED} = 15\text{mA}$.

Parameter	Min.	Typ.	Max.	Units	Conditions
V_{CC}	2.7		5.5	V	
Shutdown Current		0.04	1	μA	EN=Low
V_{LED} Dropout Voltage, V_D^1		135	200	mV	$V_{CC}=5.5\text{V}$, $I_{LED}=20\text{mA}$
LED to LED Current Matching	1	0.2	1	%	$V_{CC}=5.5\text{V}$, $V_D>200\text{mV}$
LED Current Line Regulation ²			0.3	%/V	$2.7\text{V} < V_{CC} < 5.5\text{V}$
LED Current Load Regulation ³			0.3	mA/V	$V_{CC}=3.7\text{V}$, $150\text{mV} < V_D < 1.0\text{V}$
LED Current Thermal Regulation		0.01		%/°C	$V_D=300\text{mV}$
EN ON Voltage (High) ⁴	2.4		V_{CC}	V	
EN OFF Voltage (Low)	0		0.8	V	
EN Input Bias Current	2	3	5	μA	$V_{EN} = V_{CC}=5.5\text{V}$
EN Switching Frequency			20	kHz	
EN ON Minimum Pulse Width			15	μs	
LED Current per Channel	10		25	mA	
I_{SET} Voltage	1.17	1.21	1.26	V	$V_{EN} = V_{CC}=3.7\text{V}$
I_{SET} Current Multiplication Ratio	200	205	210		$V_{EN} = V_{CC}=3.7\text{V}$

Note 1: Difference between V_{CC} voltage and LED anode voltage at which I_{LED} current drops 10% from nominal value

Note 2: I_{LED} current variations per volt V_{CC} change

Note 3: I_{LED} current variations at V_D change from 0.15 to 1.0V

Note 4: EN input voltage should not exceed V_{CC} voltage at any condition

BLOCK DIAGRAM

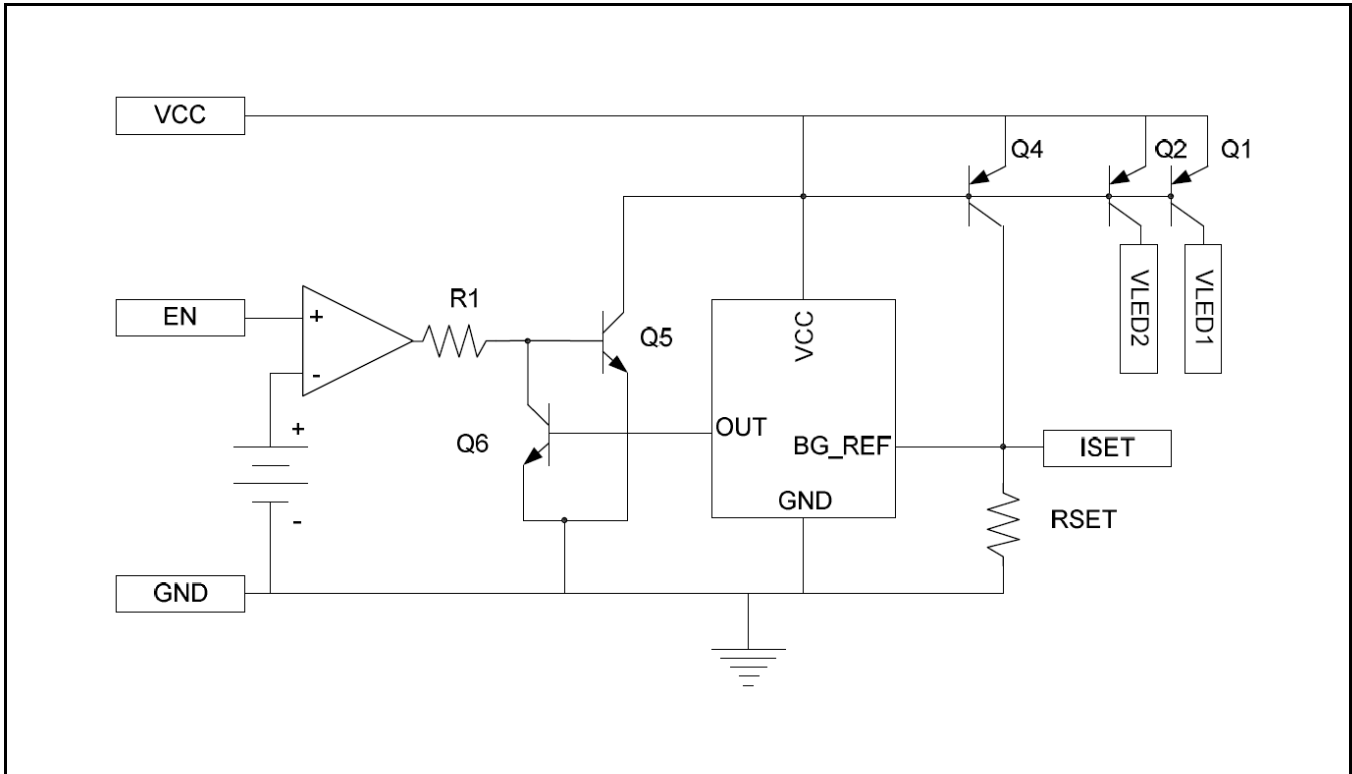

Fig. 2: SP7121 Block Diagram

PIN ASSIGNMENT

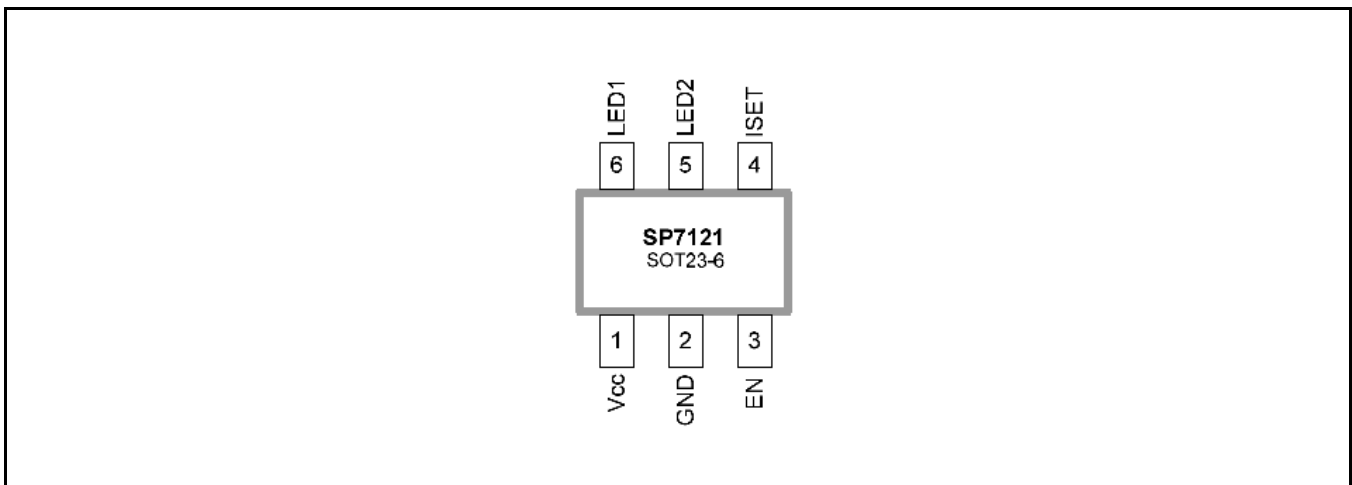

Fig. 3: SP7121 Pin Assignment



SP7121

2-Channel Adjustable Low Dropout High Side Linear LED Driver

PIN DESCRIPTION

Name	Pin Number	Description
Vcc	1	Power Input Pin. Bypass V _{CC} to GND with 1nF capacitor as close to V _{IN} as possible
GND	2	Ground Pin
EN	3	Enable Pin. Device is active if EN is logic HIGH
ISET	4	Connect external resistor to set LED current
LED2	5	Connect anode of LED 2
LED1	6	Connect anode of LED 1

ORDERING INFORMATION

Part Number	Temperature Range	Marking	Package	Packing Quantity	Note 1	Note 2
SP7121EK-L	-40°C ≤ T _A ≤ +85°C	NAWW	6-pin SOT23	Bulk	RoHS compliant Lead Free	
SP7121EK-L/TR	-40°C ≤ T _A ≤ +85°C	NAWW	6-pin SOT23	2.5K/Tape & Reel	RoHS compliant Lead Free	
SP7121EK-F	-40°C ≤ T _A ≤ +85°C	BCWW	6-pin SOT23	Bulk	RoHS compliant Halogen Free	
SP7121EK-F/TR	-40°C ≤ T _A ≤ +85°C	BCWW	6-pin SOT23	2.5K/Tape & Reel	RoHS compliant Halogen Free	
SP7121EB	SP7121 Evaluation Board					

"WW" = Work Week

TYPICAL PERFORMANCE CHARACTERISTICS

PWM Function – 2 LEDs

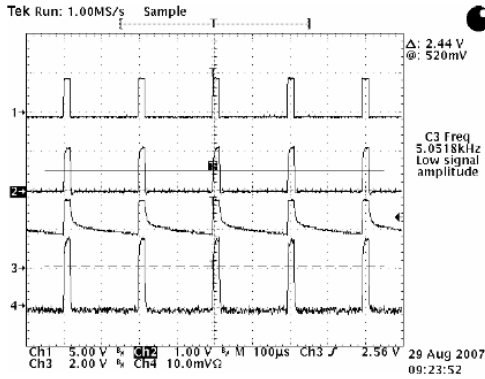

PWM minimum duty cycle 5kHz
 Channel 1 PWM signal; Channel 2 ISET pin;
 Channel 3 VLED; Channel 4 ILED 20ma/Div

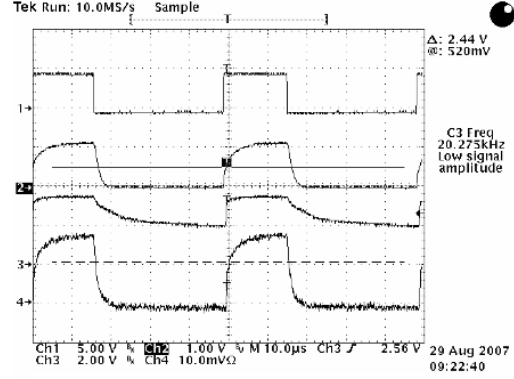

PWM minimum duty cycle 20kHz
 Channel 1 PWM signal; Channel 2 ISET pin;
 Channel 3 VLED; Channel 4 ILED 20ma/Div

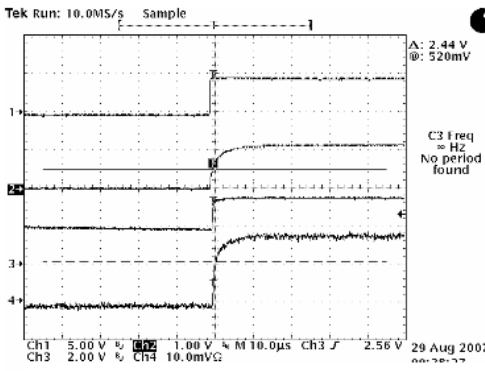

Zoom of the startup
 Channel 1 Enable; Channel 2 ISET pin;
 Channel 3 VLED; Channel 4 ILED 20ma/Div

PWM Function – 1 High Power LED

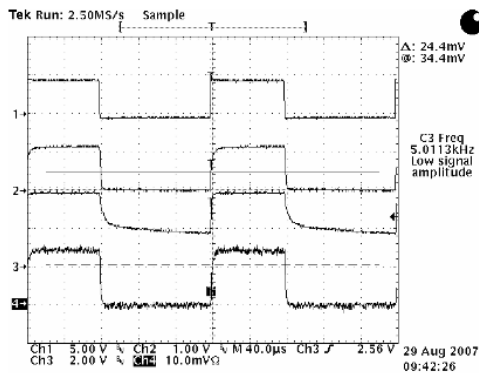

PWM minimum duty cycle 20kHz
 Channel 1 PWM signal; Channel 2 ISET pin;
 Channel 3 VLED; Channel 4 ILED 50ma/Div

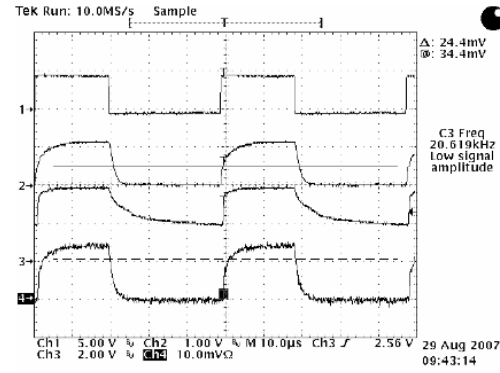

PWM minimum duty cycle 20kHz
 Channel 1 PWM signal; Channel 2 ISET pin;
 Channel 3 VLED; Channel 4 ILED 50ma/Div



SP7121

2-Channel Adjustable Low Dropout High Side Linear LED Driver

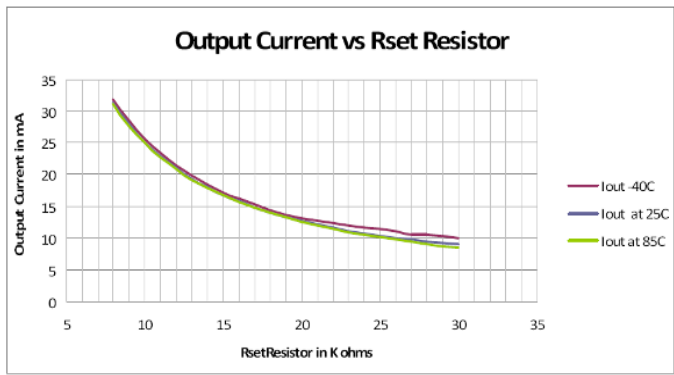
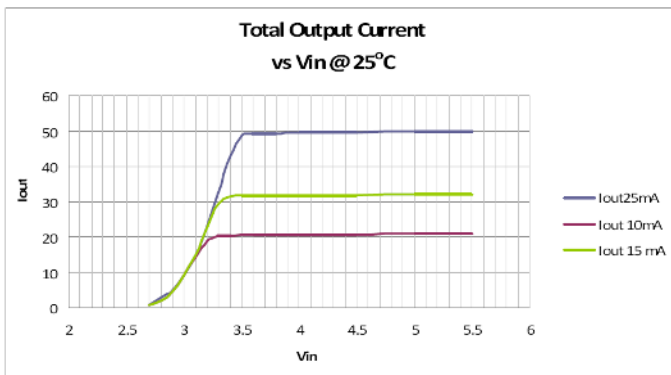
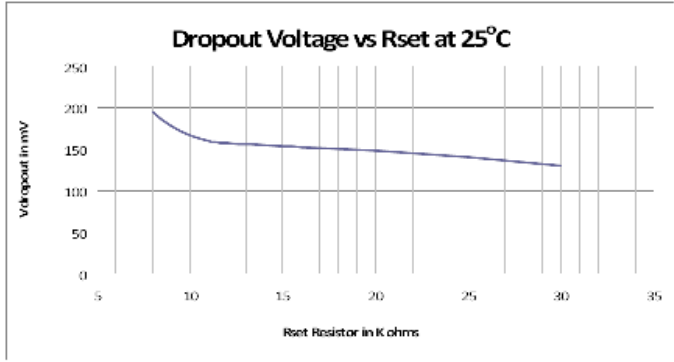
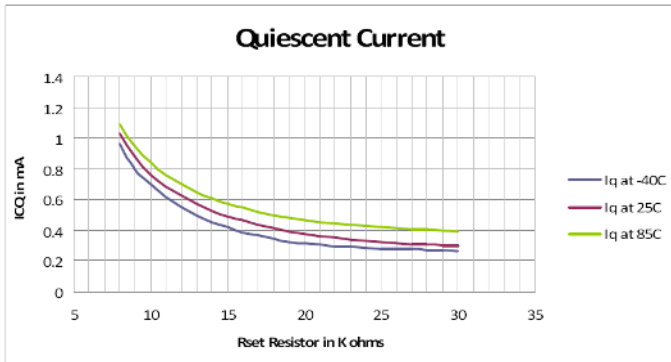



SP7121

2-Channel Adjustable Low Dropout High Side Linear LED Driver

THEORY OF OPERATION

The SP7121 allows the LED current level to be adjusted by an external resistor connected to the ISET pin. This option lets customer select the LED current amplitude by selecting appropriate external RSET resistor value. The SP7121 circuit consists of enable, bandgap reference, and current amplifier circuit blocks. The Enable circuit block provides the enable and PWM function for the IC. The bandgap reference provides a stable voltage source from which the output current is derived.

SETTING THE CURRENT IN THE SP7121

The internal current amplifier provides a current gain function where the RSET resistor is connected from the ISET pin (pin 4) to GND. The current, produced by the RSET resistor is then amplified and delivered to the LED output. The external RSET resistor value for SP7121 is determined by following equation:

$$R_{SET} = 200 \times \frac{V_{SET}}{I_{LED}}$$

Where I_{LED} = required LED current in mA per channel, $V_{SET} = 1.22V$, 200 is the typical gain.

The LED current level can be set anywhere from 10mA to 25mA per each output. Specifications are not guaranteed for current levels that are set outside this range.

The SP7121 doesn't have protection from ISET pin being shorted to ground or the R_{SET} value being too low. With an operational maximum current of 30mA per channel device may be damaged if the ISET pin is shorted to the ground or the R_{SET} value is below 8k Ω .

ENABLE

The SP7121 driver has a low current shutdown function. In shutdown mode, the part draws less than 1 μ A current maximum. The part can be shut down using the EN pin (EN = LOW). The enable pin cannot be tristated or left floating. There are no predefined internal states, so leaving this pin open will cause the part to operate incorrectly.

PWM DIMMING

The SP7121 driver allows LED-dimming control by applying a PWM signal to the EN pin. The acceptable frequency range of this signal is 100Hz to 20 kHz. The minimum ON time that is required for the ISET pin to set is 15 μ s from the time the Enable pin goes high. Thus, for a 2kHz PWM signal, the acceptable duty cycle range is 3% to 100%. To find the minimum PWM duty cycle the following steps need to be followed.

Step 1: Determine the time period of the PWM frequency.

$$\tau = \frac{1}{PWMf}$$

Where PWMf is the PWM frequency.

Step 2: Obtain the minimum Enable ON time, this is 15 μ s for the SP7121 device.

$$\%Minimum\ Duty\ Cycle = \left(\frac{15\mu s}{\tau}\right) \times 100$$

Example:

For a 2kHz signal, the minimum duty cycle for the PWM signal is

$$\tau = \frac{1}{2000Hz} = 500\mu s$$

$$\%Minimum\ Duty\ Cycle = \left(\frac{15\mu s}{500\mu s}\right) \times 100 = 3\%$$

FAULT OPERATION

If one of the LEDs is shorted, the LED voltage at this pin will be VCC but that channel will provide the nominal current value, thereby increasing power dissipation. If all channels are shorted, excessive power dissipation may damage the device. If an LED is open, the LED pin voltage will be pulled up to Vcc, and the LED current will be reduced to 3mA for the other channels.

The SP7121 doesn't have protection from the ISET pin being shorted to ground or the R_{SET} value being too low. With an operational maximum current of 30mA per channel, the device may be damaged if the ISET pin is shorted to the ground or the R_{SET} value is below 8k Ω .

THERMAL CONSIDERATIONS

The SP7121 does not have over temperature protection. Special care needs to be taken to ensure that the driver's junction temperature stays below 125°C. The thermal resistance of the package is 190°C per Watt. Under normal operation conditions with about 30mA of current per LED and a voltage drop across the part of 1V, the part will still only dissipate 0.06 Watts, giving a temperature rise of only 11.4°C.

Example of thermal calculation:

$$P = V_D \times I_{OUT}$$

Where P is the total power dissipation, V_D is the voltage drop across the SP7121, I_{OUT} is the total output current.

$$\text{Temperature Rise} = P \times \theta_{JA}$$

Where P is the total power dissipation, θ_{JA} is the thermal resistance of the package per Watt.

Above example:

$$P = 1V \times 60mA = 0.06W$$

$$\text{Temperature Rise} = 0.06W \times 190 = 11.4^\circ C$$

The device will be able to operate up to 85°C under these conditions.

BOARD LAYOUT AND GROUNDING

Although the SP7121 does not require an input capacitor for normal operation, a 1nF capacitor can be used to obtain better overall circuit performance. To obtain the best performance from the SP7121, a printed circuit board with ground plane is required. High quality, low series resistance ceramic 1nF bypass capacitors should be used at the Vcc and GND pins (pins 1 and 2). This capacitor must be located as close to the pins as possible. The traces connecting the pins and the capacitor must be kept short and should be made as wide as possible.

APPLICATION SCHEMATICS

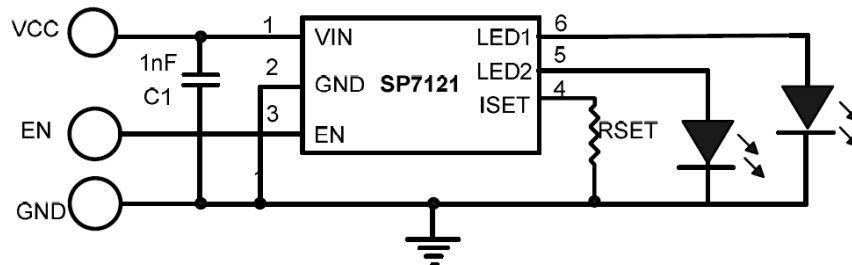

SP7121 Powering 2 LEDs

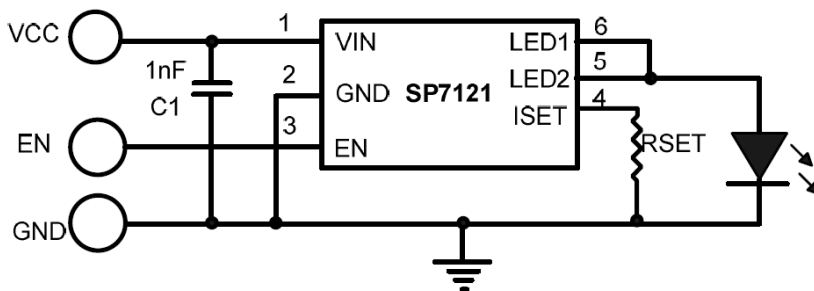

Powering high 1 high power LED with SP7121 IOUT up to 50mA



SP7121

2-Channel Adjustable Low Dropout High Side Linear LED Driver

PACKAGE SPECIFICATION

6-PIN SOT23

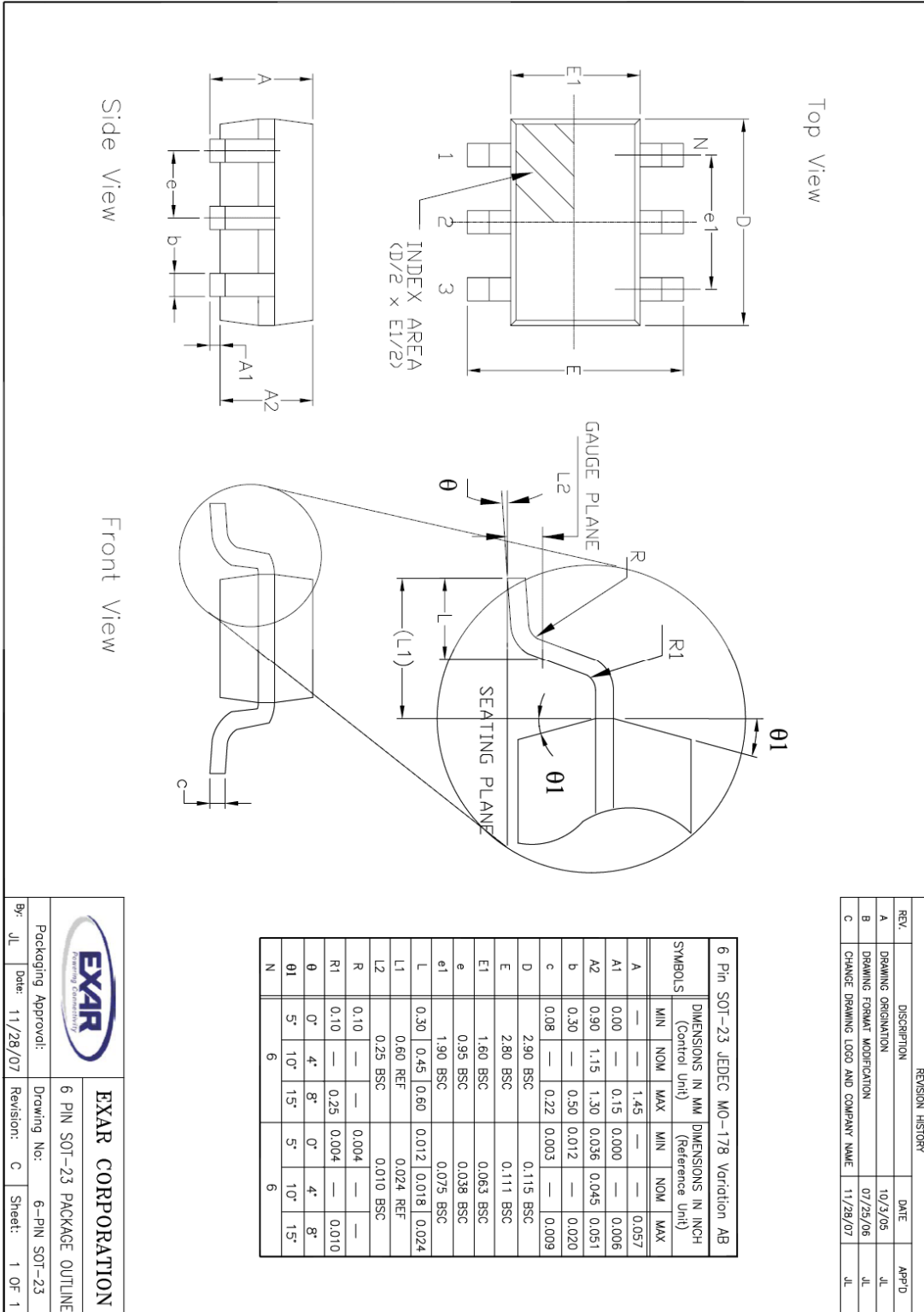

REVISION HISTORY			
REV.	DESCRIPTION	DATE	APP'D
A	DRAWING ORIGINATOR	10/3/05	JL
B	DRAWING FORMAT MODIFICATION	07/25/06	JL
C	CHANGE DRAWING LOGO AND COMPANY NAME	11/29/07	JL

		EXAR CORPORATION	
Packaging Approval:		Drawing No: 6-PIN SOT-23 PACKAGE OUTLINE	
By: JL	Date: 11/28/07	Revision: C	Sheet: 1 OF 1



SP7121 2-Channel Adjustable Low Dropout High Side Linear LED Driver

REVISION HISTORY

Revision	Date	Description
2.0.0	01/12/2010	Reformat of Datasheet and addition of the -F option.

FOR FURTHER ASSISTANCE

Email:

customersupport@exar.com

Exar Technical Documentation:

<http://www.exar.com/TechDoc/default.aspx?>

EXAR CORPORATION

HEADQUARTERS AND SALES OFFICES

48720 Kato Road

Fremont, CA 94538 – USA

Tel.: +1 (510) 668-7000

Fax: +1 (510) 668-7030

www.exar.com



NOTICE

EXAR Corporation reserves the right to make changes to the products contained in this publication in order to improve design, performance or reliability. EXAR Corporation assumes no responsibility for the use of any circuits described herein, conveys no license under any patent or other right, and makes no representation that the circuits are free of patent infringement. Charts and schedules contained here in are only for illustration purposes and may vary depending upon a user's specific application. While the information in this publication has been carefully checked; no responsibility, however, is assumed for inaccuracies.

EXAR Corporation does not recommend the use of any of its products in life support applications where the failure or malfunction of the product can reasonably be expected to cause failure of the life support system or to significantly affect its safety or effectiveness. Products are not authorized for use in such applications unless EXAR Corporation receives, in writing, assurances to its satisfaction that: (a) the risk of injury or damage has been minimized; (b) the user assumes all such risks; (c) potential liability of EXAR Corporation is adequately protected under the circumstances.

Reproduction, in part or whole, without the prior written consent of EXAR Corporation is prohibited.