

Wide range single-output demonstration board based on the VIPER37LE

Data brief

Features

- Universal input mains range:
 - input voltage 90 - 264 V_{AC}
 - frequency 45 - 65 Hz
- Single-output voltage: 5 V @ 3 A continuous operation
- Standby mains consumption: < 30 mW @ 230 V_{AC}
- Average efficiency: > 75%
- Complies with EuP Lot 6 requirements
- Fully protected against faults overload, overvoltage, transformer saturation and overheating
- Compliant with EMC norm EN55022-Class-B
- RoHS compliant

Description

The STEVAL-ISA121V1 demonstration board implements a 15 W single-output wide range mains power supply to be used as an auxiliary adapter in applications such as LCD, plasma or LED TVs, desktop computers, etc., when the main power supply is OFF or in standby mode and the auxiliary power supply must provide energy only to some specific parts of the equipment such as USB ports, remote receiver, etc.

The board uses the new VIPER37LE, an offline high voltage converter from the VIPerPlus family, specifically designed for fixed frequency flyback converters, which combines a high-performance low voltage PWM controller chip and a max. 4.5 Ω R_{DS(on)}, 800 V B_{V(DSS)}, avalanche-rugged power MOSFET in the same package.

The application is optimized for less than 30 mW standby consumption and meets EPA 2.0 limits, thereby helping to meet the most stringent energy-saving requirements.



The board implements several protection features that considerably increase end-product safety and reliability: overload protection, overvoltage protection, brownout protection, hysteretic thermal protection, shorted secondary rectifier detection, and transformer saturation protection, all of which are in auto-restart mode.

1 Schematic diagram

Figure 1. STEVAL-ISA121V1 electrical diagram

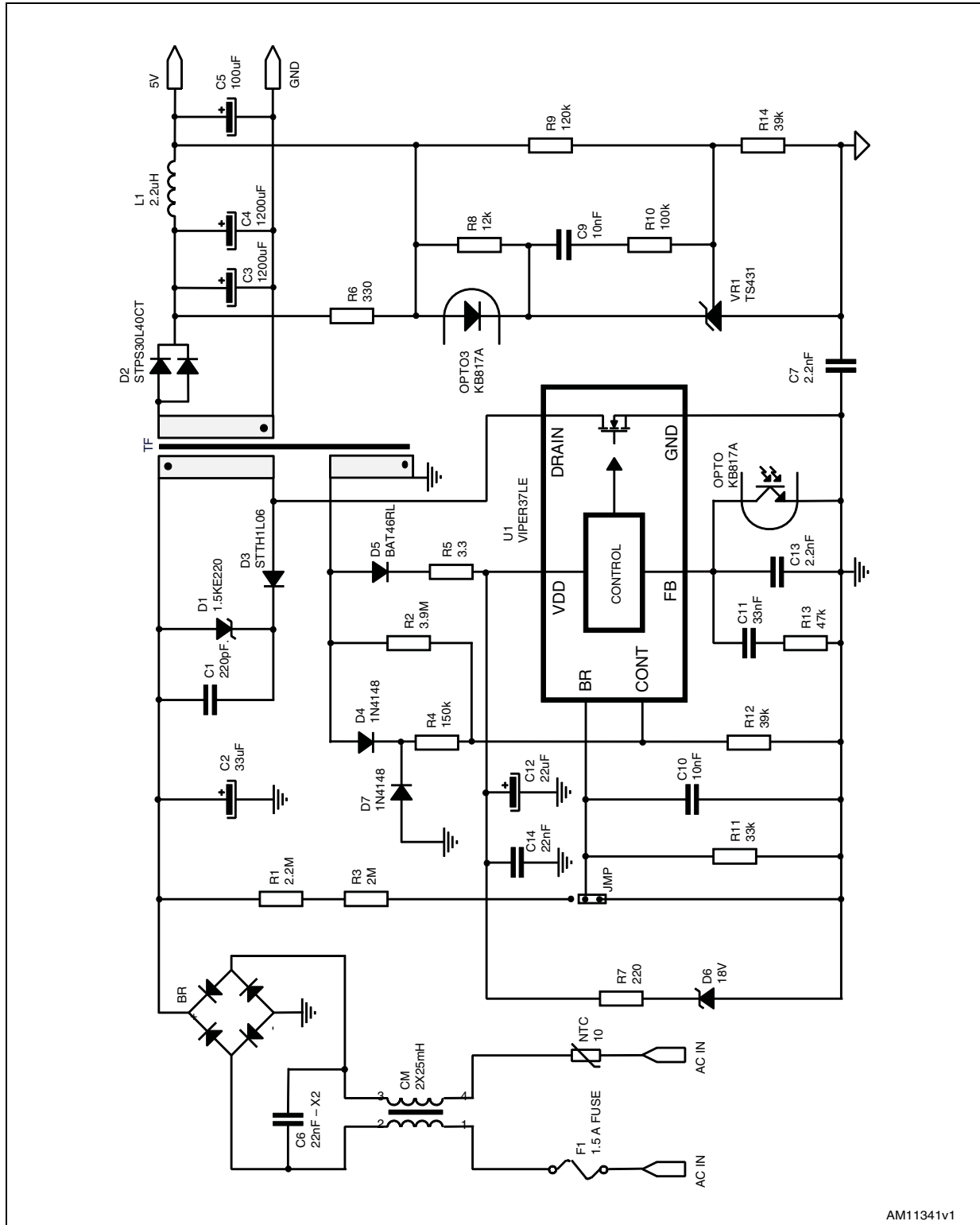

AM11341v1

2 Output characteristics

Figure 2. Line and load regulation

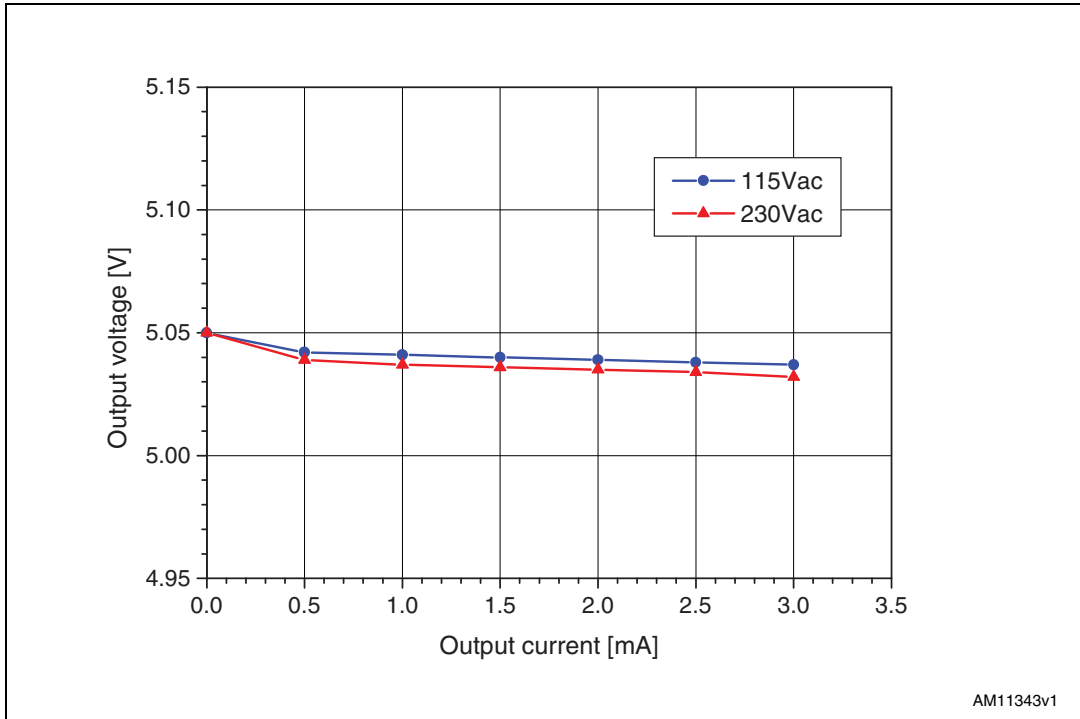

Figure 3. No load consumption

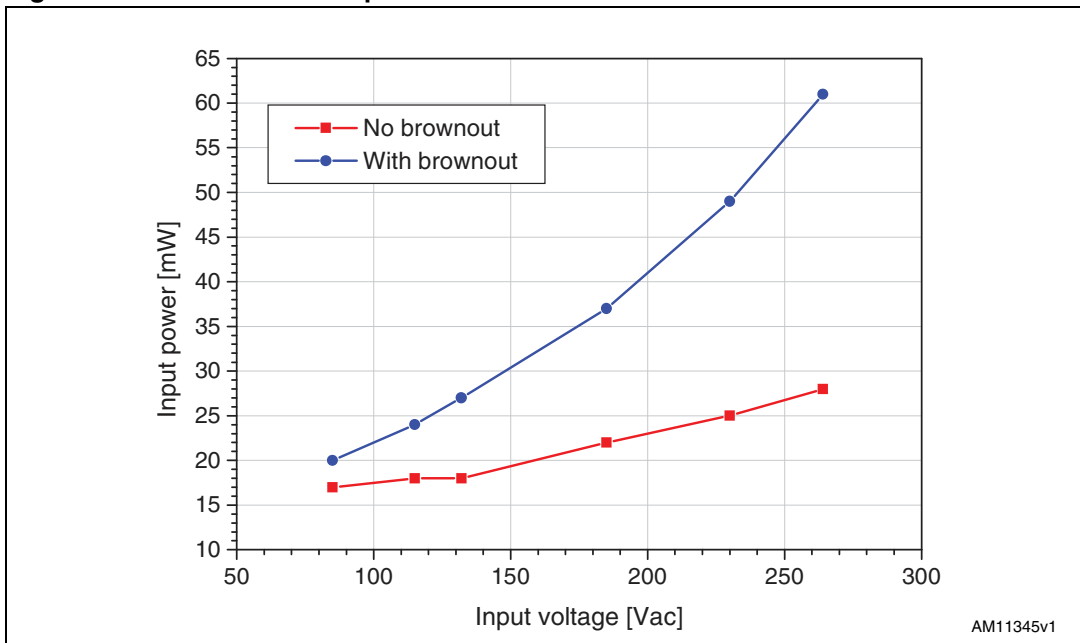
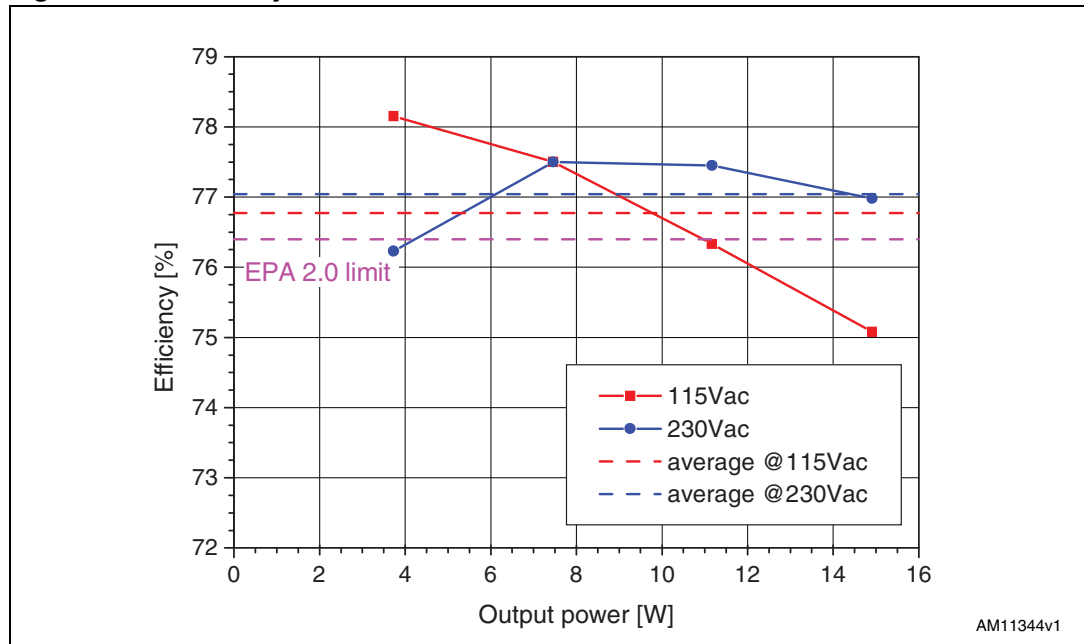

Figure 4. Efficiency



3 Revision history

Table 1. Document revision history

Date	Revision	Changes
09-Jan-2013	1	Initial release.

Please Read Carefully:

Information in this document is provided solely in connection with ST products. STMicroelectronics NV and its subsidiaries ("ST") reserve the right to make changes, corrections, modifications or improvements, to this document, and the products and services described herein at any time, without notice.

All ST products are sold pursuant to ST's terms and conditions of sale.

Purchasers are solely responsible for the choice, selection and use of the ST products and services described herein, and ST assumes no liability whatsoever relating to the choice, selection or use of the ST products and services described herein.

No license, express or implied, by estoppel or otherwise, to any intellectual property rights is granted under this document. If any part of this document refers to any third party products or services it shall not be deemed a license grant by ST for the use of such third party products or services, or any intellectual property contained therein or considered as a warranty covering the use in any manner whatsoever of such third party products or services or any intellectual property contained therein.

UNLESS OTHERWISE SET FORTH IN ST'S TERMS AND CONDITIONS OF SALE ST DISCLAIMS ANY EXPRESS OR IMPLIED WARRANTY WITH RESPECT TO THE USE AND/OR SALE OF ST PRODUCTS INCLUDING WITHOUT LIMITATION IMPLIED WARRANTIES OF MERCHANTABILITY, FITNESS FOR A PARTICULAR PURPOSE (AND THEIR EQUIVALENTS UNDER THE LAWS OF ANY JURISDICTION), OR INFRINGEMENT OF ANY PATENT, COPYRIGHT OR OTHER INTELLECTUAL PROPERTY RIGHT.

UNLESS EXPRESSLY APPROVED IN WRITING BY TWO AUTHORIZED ST REPRESENTATIVES, ST PRODUCTS ARE NOT RECOMMENDED, AUTHORIZED OR WARRANTED FOR USE IN MILITARY, AIR CRAFT, SPACE, LIFE SAVING, OR LIFE SUSTAINING APPLICATIONS, NOR IN PRODUCTS OR SYSTEMS WHERE FAILURE OR MALFUNCTION MAY RESULT IN PERSONAL INJURY, DEATH, OR SEVERE PROPERTY OR ENVIRONMENTAL DAMAGE. ST PRODUCTS WHICH ARE NOT SPECIFIED AS "AUTOMOTIVE GRADE" MAY ONLY BE USED IN AUTOMOTIVE APPLICATIONS AT USER'S OWN RISK.

Resale of ST products with provisions different from the statements and/or technical features set forth in this document shall immediately void any warranty granted by ST for the ST product or service described herein and shall not create or extend in any manner whatsoever, any liability of ST.

ST and the ST logo are trademarks or registered trademarks of ST in various countries.

Information in this document supersedes and replaces all information previously supplied.

The ST logo is a registered trademark of STMicroelectronics. All other names are the property of their respective owners.

© 2013 STMicroelectronics - All rights reserved

STMicroelectronics group of companies

Australia - Belgium - Brazil - Canada - China - Czech Republic - Finland - France - Germany - Hong Kong - India - Israel - Italy - Japan - Malaysia - Malta - Morocco - Philippines - Singapore - Spain - Sweden - Switzerland - United Kingdom - United States of America

www.st.com