

<TABLE 1>

	MATERIAL NO.	ORDER NO.	PACKING	COLOR
TYPE - D	1040040915	104004-0915	TRAY	GRAY

NOTE

- MATES WITH :
(MOLEX SERIES NO. - 111014, 111015, 111005, 111041, 111019, 111020)
- SHROUD GEOMETRY AND ASSEMBLY WITH USB MINI-B CONNECTOR ARE ACCORDING TO USCAR STD 999-U-USB-Z01
- FINISHES
- TERMINAL :
CONTACT AREA : Au 0.75 μ m MIN.
SOLDER TAIL AREA : TIN 3.84 μ m MIN.
UNDER PLATING : NI 1.04 μ m MIN.
- SHIELD CASE :
3.0 μ m MIN. TIN OVER NI 1.04 μ m MIN.
- FITTING NAIL :
3.0 μ m MIN. TIN OVER NI 1.04 μ m MIN.
- UNLESS OTHERWISE SPECIFIED, TYPICAL RECOMMENDED PCB MANUFACTURING TOLERANCE IS ± 0.05
- PACKAGING IS TRAY :
(48 PCS/TRAY, 5 TRAY/TRAY BOX, 240 PCS/TRAY BOX, 960 PCS/CARTON BOX)
- PRODUCT SPECIFICATION : PS-49616-001
- PACKAGING INFORMATION : PK-104004-003
- PCB THICKNESS : 2.36mm(REFERENCE)

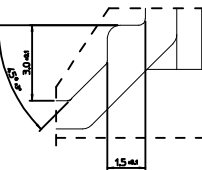
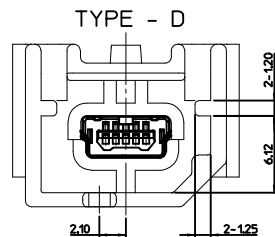
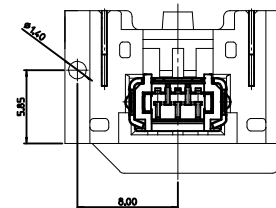
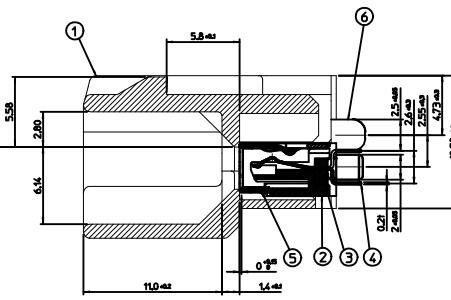
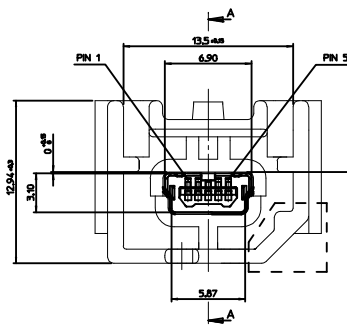

<PARTS LIST>

NO.	PART NAME	MATERIAL
1	SHROUD-D	LCP, GLASS FILLED, UL94 V-0
2	RECEPTACLE HOUSING	LCP, GLASS FILLED, UL94 V-0
3	CONTACT HOUSING	LCP, GLASS FILLED, UL94 V-0
4	CONTACT TERMINAL	COPPER ALLOY
5	SHIELD CASE	PHOSPHOR BRONZE
6	BOARD LOCKS PIN	BRASS

REVISED EC NO: KTR2015-0098 DRAWN BY: DWINY IBAEK CHKD: JYCHOI APPR: JYCHOI DATE: 2015/04/17 DATE: 2015/05/04 A1	QUALITY SYMBOLS 0 0	GENERAL TOLERANCES (UNLESS SPECIFIED) 4 PLACES \pm --- \pm --- 3 PLACES \pm --- \pm --- 2 PLACES ± 0.15 \pm --- 1 PLACE ± 0.25 \pm --- ANGULAR $\pm 1^\circ$	DIMENSION STYLE MM ONLY	SCALE 5:1	DESIGN UNITS METRIC	THIRD ANGLE PROJECTION
			DRAWN BY S. M. KIM	DATE 2009/06/17	TITLE USCAR USB MINI B CONN. VERTICAL-D (LONG TERMINAL VERSION)	
			CHECKED BY B. C. YOON	DATE 2009/06/17	MOLEX INCORPORATED	
			APPROVED BY JYCHOI	DATE 2014/08/01	MATERIAL NO. SEE TABLE 1	DOCUMENT NO. SD-104004-009

DRAFT WHERE APPLICABLE MUST REMAIN WITHIN DIMENSIONS

THIS DRAWING CONTAINS INFORMATION THAT IS PROPRIETARY TO MOLEX INCORPORATED AND SHOULD NOT BE USED WITHOUT WRITTEN PERMISSION