

PTH PATTERN
SCALE 1:1

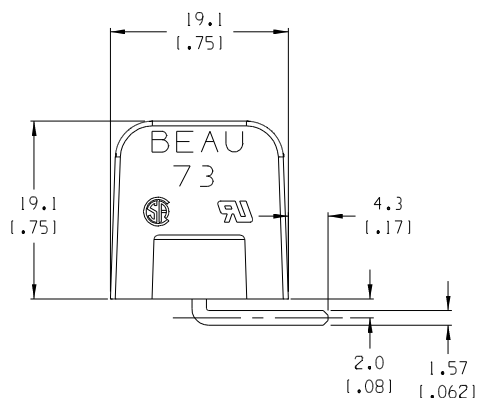
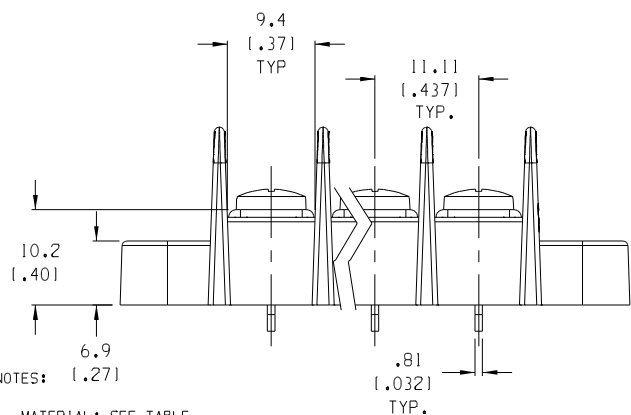

| NUMBER OF CIRCUITS | "A" DIM. | "B" DIM. | "C" DIM. | MATERIAL NUMBER |
|--------------------|---------------|---------------|---------------|-----------------|
| 03 | 54.62 [2.150] | 22.23 [0.875] | 44.46 [1.750] | 387322103 |
| 04 | 65.73 [2.588] | 33.34 [1.313] | 55.57 [2.188] | 387322104 |
| 05 | 76.84 [3.025] | 44.45 [1.750] | 66.68 [2.625] | 387322105 |

- NOTES: [.27]
1. MATERIAL: SEE TABLE
 2. FINISHES: SEE TABLE
 3. PRODUCT SPECIFICATION: AS REQUIRED
 4. PACKAGING: NOT REQUIRED
 5. MATES WITH: NONE
 6. INCH DIMS ARE SHOWN IN PARENTHESIS (XXX)
 7. "XX" REFERS TO THE NUMBER OF CIRCUITS

| ITEM | QTY. | DESCRIPTION | MATERIAL | FINISH |
|------|------|---------------------------------|---------------|---------------|
| 3 | "XX" | SCREW #8-32 X .290 BINDING HEAD | STEEL | ZINC CHROMATE |
| 2 | "XX" | TERMINAL 8-32, WIRE WRAP | BRASS | TIN |
| 1 | 1 | INSULATOR | THERMOPLASTIC | BLACK |

EC NO. RELEASED
DRAWN: JF 07-29-04
CH: K1
APPR:

DESCRIPTION
MAJOR
CRITICAL
SPC
S

QUALITY SYMBOLS
GENERAL TOLERANCES: (UNLESS SPECIFIED)
mm INCH
4 PLACES ±.0015
3 PLACES ±.038 ±.005
2 PLACES ±.13 ±.01
1 PLACE ±.3
ANGULAR: ±2°
DRAFT WHERE APPLICABLE MUST REMAIN WITHIN DIMENSIONS

SCALE 2:1
DESIGN UNITS
 mm INCH
DRAWN BY & DATE
J. FARMER 07-29-04
CHECKED BY & DATE
APPROVED BY & DATE
CAD FILENAME
738XX-A.PRT

PROJECT NO. - -
DIMENSIONS: mm INCH mm ONLY
SHT REV
REVISE ON CAD ONLY
TITLE:
SR BTS, PC, RA, -A, ASY
MOLEX INCORPORATED
MATERIAL NO. SEE CHART
DRAWING NO. SD-38732-001
SHEET NO. 1 OF 1
SIZE B
THIS DRAWING CONTAINS INFORMATION THAT IS PROPRIETARY TO MOLEX INCORPORATED AND SHOULD NOT BE USED WITHOUT WRITTEN PERMISSION.