

## ADP3421

### FEATURES

- Meets Intel® Mobile Voltage Positioning Requirements
- Lowest Processor Dissipation for Longest Battery Life
- Best Transient Containment
- Minimum Number of Output Capacitors
- System Power Management Compliant
- Fast, Smooth Output Transition During VID Code Change
- Programmable Current Limit
- Power Good
- Integrated LDO Controllers for Clock and I/O Supplies
- Programmable UVLO
- Soft Start with Restart Lock-In

### APPLICATIONS

- Geyserville-Enabled Core DC-DC Converters
- Fixed Voltage Mobile CPU Core DC-DC Converters
- Notebook/Laptop Power Supplies
- Programmable Output Power Supplies

### GENERAL DESCRIPTION

The ADP3421 is a hysteretic dc-dc buck converter controller with two auxiliary linear regulator controllers. The ADP3421 provides a total power conversion control solution for a micro-processor by delivering the core, I/O, and clock voltages. The optimized low-voltage design is powered from the 3.3 V system supply and draws only 10  $\mu$ A maximum in shutdown. The main output voltage is set by a 5-bit VID code. To accommodate the transition time required by the newest processors for on-the-fly VID changes, the ADP3421 features high-speed operation to allow a minimized inductor size that results in the fastest change of current to the output. To further allow for the minimum number of output capacitors to be used, the ADP3421 features active voltage positioning that can be optimally compensated to ensure a superior load transient response. The main output signal interfaces with the ADP3410 dual MOSFET driver, which is optimized for high speed and high efficiency for driving both the upper and lower (synchronous) MOSFETs of the buck converter.

### FUNCTIONAL BLOCK DIAGRAM

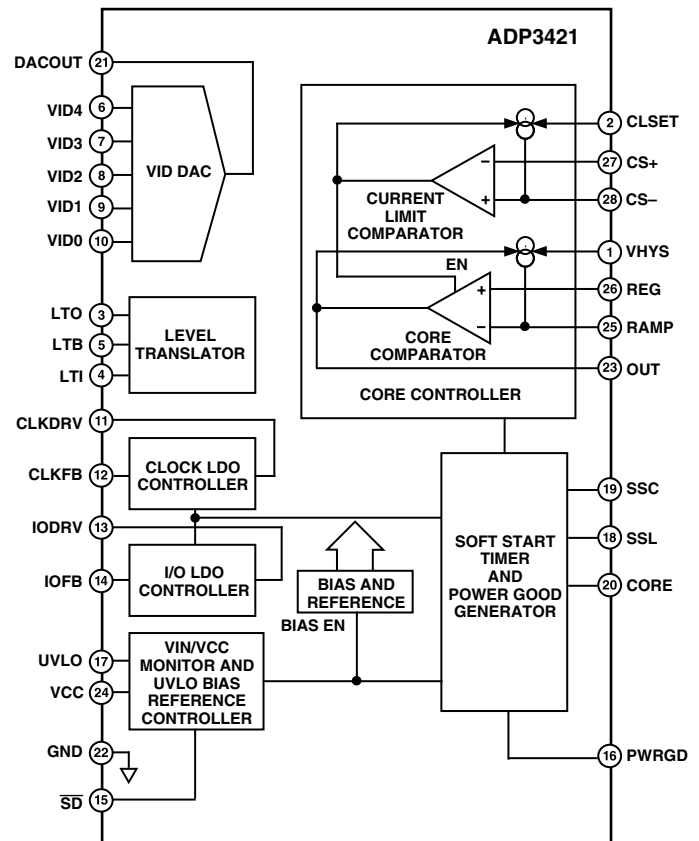

### REV. A

Information furnished by Analog Devices is believed to be accurate and reliable. However, no responsibility is assumed by Analog Devices for its use, nor for any infringements of patents or other rights of third parties that may result from its use. No license is granted by implication or otherwise under any patent or patent rights of Analog Devices.

# ADP3421—SPECIFICATIONS<sup>1</sup> ( $0^{\circ}\text{C} \leq T_A \leq 100^{\circ}\text{C}$ , $V_{CC} = 3.3\text{ V}$ , $V_{SD} = V_{CC}$ , $V_{ULVO} = 2.0\text{ V}$ , $V_{CORE} = V_{DAC}$ , $R_{OUT} = 100\text{ k}\Omega$ , $C_{OUT} = 10\text{ pF}$ , $C_{SSC} = 1.8\text{ nF}$ , $C_{SSL} = 1.3\text{ nF}$ , $C_{LTB} = 1.5\text{ nF}$ , unless otherwise noted.)

Parameter	Symbol	Conditions	Min	Typ	Max	Unit	
<b>SUPPLY-UVLO-POWER GOOD</b>							
Supply Current	$I_{CC(ON)}$	$V_{UVLO} = 0.2\text{ V}$ $V_{SD} = 0\text{ V}$ , $3.0\text{ V} \leq V_{CC} \leq 3.6\text{ V}$		7	15	mA	
	$I_{CC(UVLO)}$					350	$\mu\text{A}$
	$V_{CCH}$					10	$\mu\text{A}$
VCC UVLO Threshold	$I_{CCH}$				2.9	V	
	$V_{CCL}$		2.7			V	
VCC UVLO Hysteresis	$V_{CCHYS}$		20			mV	
Battery UVLO Threshold	$V_{UVLOTH}$		1.175	1.225	1.275	V	
Battery UVLO Hysteresis	$I_{UVLO}$	$V_{UVLO} = 1.275\text{ V}$ $V_{UVLO} = 1.175\text{ V}$	-0.3		+0.3	$\mu\text{A}$	
Shutdown Input Threshold	$V_{SDTH}$	$3.0\text{ V} < V_{CC} < 5.0\text{ V}$	0.6	1.0	1.4	$\mu\text{A}$	
Core Power Good Threshold	$V_{SDTH}$	$3.0\text{ V} < V_{CC} < 5.0\text{ V}$	0.8		$0.7 \times V_{CC}$	V	
	$V_{COREH(UP)}^1$	$0.925\text{ V} < V_{DAC} < 2.000\text{ V}$		$1.10 \times V_{DAC}$	$1.12 \times V_{DAC}$	V	
	$V_{COREH(DN)}^2$			$1.08 \times V_{DAC}$	$1.10 \times V_{DAC}$	V	
	$V_{COREL(UP)}^1$			$0.90 \times V_{DAC}$	$0.92 \times V_{DAC}$	V	
	$V_{COREL(DN)}^2$			$0.88 \times V_{DAC}$	$0.90 \times V_{DAC}$	V	
	$V_{PWRGD}^3$		$V_{CORE} = V_{DAC}$ $V_{CORE} = 0.8 V_{DAC}$ $V_{UVLO} = 0.2\text{ V}$	$0.95 \times V_{CC}$		$V_{CC}$	V
PWRGD Output Voltage			0		0.8	V	
			0		0.4	V	
<b>CORE CONVERTER SOFT-START TIMER</b>							
Timing Charge Current	$I_{SSC(UP)}$	$V_{SSC} = 0\text{ V}$ $V_{SSC} = 1.7\text{ V}$ , $V_{UVLO} = 1.1\text{ V}$	-0.6	-1.0	-1.4	$\mu\text{A}$	
Discharge Current	$I_{SSC(DN)}$		0.3	1.0		mA	
Enable Threshold	$V_{SSCEN}^4$			150	400	mV	
Termination Threshold	$V_{SSCTH}$			1.53	1.70	1.87	V
<b>VID DAC</b>							
VID Input Threshold	$V_{VID0..4}$	See VID Code Table I	0.8		$0.7 \times V_{CC}$	V	
VID Input Pull-Up Current	$I_{VID0..4}$		10		40	$\mu\text{A}$	
Nominal Output Voltage	$V_{DAC}$		0.925		2.000	V	
Output Voltage Accuracy	$\Delta V_{DAC}/V_{DAC}$		-0.85		0.85	%	
Output Voltage Settling Time	$t_{DAC5}$				35	$\mu\text{s}$	
<b>CORE COMPARATOR</b>							
Input Offset Voltage	$V_{COREOS}$	$V_{REG} = 1.3\text{ V}$	-3		+3	mV	
Input Bias Current	$I_{REG}$	$V_{REG} = V_{RAMP} = 1.3\text{ V}$	-2		+2	$\mu\text{A}$	
Hysteresis Current	$I_{RAMP}$	$V_{CORE} = V_{RAMP} = 1.3\text{ V}$ $V_{CS-} = 1.30\text{ V}$ , $V_{CS+} = 1.28\text{ V}$ $V_{REG} = 1.28\text{ V}$					
		$R_{VHYS}$ Open	-2		+2	$\mu\text{A}$	
		$R_{VHYS} = 170\text{ k}\Omega$	-7	-10	-13	$\mu\text{A}$	
		$R_{VHYS} = 17\text{ k}\Omega$	-82	-97	-113	$\mu\text{A}$	
		$V_{REG} = 1.32\text{ V}$					
		$R_{VHYS}$ Open	-2		+2	$\mu\text{A}$	
		$R_{VHYS} = 170\text{ k}\Omega$	7	10	13	$\mu\text{A}$	
		$R_{VHYS} = 17\text{ k}\Omega$	82	97	113	$\mu\text{A}$	
Hysteresis Setting Reference Voltage	$V_{VHYS}$		1.53	1.70	1.87	V	
Output Voltage	$V_{OUTH}$	$V_{CC} = 3.0\text{ V}$	2.5		3.0	V	
	$V_{OUTL}$	$V_{CC} = 3.6\text{ V}$	0		0.4	V	
Propagation Delay Time <sup>6</sup>	$t_{COREPD}^7$	$T_A = 25^{\circ}\text{C}$ $0^{\circ}\text{C} \leq T_A \leq 100^{\circ}\text{C}$			20	ns	
					30	ns	
Rise and Fall Time <sup>6</sup>	$t_{CORER}^8$ , $t_{COREF}^8$			7	10	ns	

Parameter	Symbol	Conditions	Min	Typ	Max	Unit
<b>CURRENT LIMIT COMPARATOR</b>						
Input Offset Voltage	$V_{CLOS}$	$V_{CS-} = 1.3\text{ V}$	-6		+6	mV
Input Bias Current	$I_{CL+}$	$V_{CS+} = 1.3\text{ V}$	-5		+5	$\mu\text{A}$
Hysteresis Current	$I_{CL-}$	$V_{CORE} = V_{RAMP} = 1.3\text{ V}$ $V_{REG} = 1.28\text{ V}, V_{CS-} = 1.3\text{ V}$ $V_{CS+} = 1.28\text{ V}$ $R_{IHYS}$ Open			-5	$\mu\text{A}$
		$R_{IHYS} = 170\text{ k}\Omega$	-22	-30	-38	$\mu\text{A}$
		$R_{IHYS} = 17\text{ k}\Omega$	-265	-300	-335	$\mu\text{A}$
		$V_{CS+} = 1.32\text{ V}$ $R_{IHYS}$ Open			-5	$\mu\text{A}$
		$R_{IHYS} = 170\text{ k}\Omega$	-13	-20	-27	$\mu\text{A}$
		$R_{IHYS} = 17\text{ k}\Omega$	-175	-200	-225	$\mu\text{A}$
Hysteresis Setting Reference Voltage	$V_{VHYS}$		1.53	1.70	1.87	V
Propagation Delay Time <sup>6</sup>	$t_{CLPD}$ <sup>7</sup>	$T_A = 25^\circ\text{C}$ $0^\circ\text{C} \leq T_A \leq 100^\circ\text{C}$		30	60	ns
				50	100	ns
<b>LINEAR REGULATOR SOFT-START TIMER</b>						
Charge Current	$I_{SSC(UP)}$	$V_{SSC} = 0\text{ V}$	-0.6	-1.0	-1.4	$\mu\text{A}$
Discharge Current	$I_{SSC(DN)}$	$V_{SSC} = 1.7\text{ V}, V_{UVLO} = 1.1\text{ V}$	0.3	1.0		mA
Enable Threshold	$V_{SSCEN}$ <sup>4</sup>			150	400	mV
Termination Threshold	$V_{SSCTH}$		1.53	1.70	1.87	V
<b>2.5 V CLK LDO CONTROLLER</b>						
Feedback Bias Current	$I_{CLKFB}$	$V_{CLKFB} = 2.5\text{ V}$		12.5	25	$\mu\text{A}$
Output Drive Current	$I_{CLKDRV}$	$V_{CLKDRV} = 2.55\text{ V}$ $V_{CLKDRV} = 2.45\text{ V}$ $\Delta I_{CLKDRV} = 1\text{ mA}$	3		1 20	$\mu\text{A}$ mA
DC Transconductance	$G_{CLK}$			500		mA/V
<b>1.5 V I/O LDO CONTROLLER</b>						
Feedback Bias Current	$I_{IOFB}$	$V_{IOFB} = 1.5\text{ V}$		7.5	15	$\mu\text{A}$
Output Drive Current	$I_{IODRV}$	$V_{IODRV} = 1.53\text{ V}$ $V_{IODRV} = 1.47\text{ V}$ $\Delta I_{CLKDRV} = 1\text{ mA}$	10		1 60	$\mu\text{A}$ mA
DC Transconductance	$G_{IO}$			650		mA/V
<b>LEVEL TRANSLATOR</b>						
Input Clamping Threshold	$V_{LTIH}$	$I_{LTI} = -10\text{ }\mu\text{A}$	0.95		1.5	V
Output Voltage	$V_{LTOH}$	$I_{LTI} = -10\text{ }\mu\text{A}$ <sup>9</sup>	$0.9 \times V_{CCLT}$		$V_{CCLT}$	V
	$V_{LTOL}$	$V_{LTI} = 0.175\text{ V}$ <sup>9</sup>			375	mV
Propagation Delay Time <sup>6</sup>	$t_{LTPD}$				10	ns

## NOTES

<sup>1</sup> $V_{CORE}$  ramps up monotonically.<sup>2</sup> $V_{CORE}$  ramps down monotonically.<sup>3</sup>During latency time of VID code change, the Power Good output signal should not be considered valid.<sup>4</sup>Internal bias and soft start are not enabled unless the soft-start pin voltage first drops below the enable threshold.<sup>5</sup>Measured from 50% of VID code transient amplitude to the point where  $V_{DAC}$  settles within  $\pm 1\%$  of its steady state value.<sup>6</sup>Guaranteed by characterization.<sup>7</sup>40 mV p-p amplitude impulse with 20 mV overdrive. Measure from the input threshold intercept point to 50% of the output voltage swing.<sup>8</sup>Measured between the 30% and 70% points of the output voltage swing.<sup>9</sup>The LTO output tied to  $V_{CCLT} = 2.5\text{ V}$  rail through an  $R_{LTO} = 150\text{ }\Omega$  pull-up resistor.

Specifications subject to change without notice.

# ADP3421

## ABSOLUTE MAXIMUM RATINGS\*

Input Supply Voltage (VCC)	−0.3 V to +7 V
UVLO Input Voltage	−0.3 V to +7 V
All Other Inputs/Outputs	VCC + 0.3 V
Operating Ambient Temperature Range	0°C to 100°C
Junction Temperature Range	0°C to 150°C
$\theta_{JA}$	98°C/W
Storage Temperature Range	−65°C to +150°C
Lead Temperature (Soldering, 10 sec.)	300°C

\*Stresses above those listed under Absolute Maximum Ratings may cause permanent damage to the device. This is a stress rating only; functional operation of the device at these or any other conditions above those indicated in the operational section of this specification is not implied. Exposure to absolute maximum rating conditions for extended periods may affect device reliability.

## ORDERING GUIDE

Model	Temperature Range	Package Description	Package Option
ADP3421JRU	0°C to 100°C	Thin Shrink Small Outline (TSSOP)	RU-28

## CAUTION

ESD (electrostatic discharge) sensitive device. Electrostatic charges as high as 4000 V readily accumulate on the human body and test equipment and can discharge without detection. Although the ADP3421 features proprietary ESD protection circuitry, permanent damage may occur on devices subjected to high energy electrostatic discharges. Therefore, proper ESD precautions are recommended to avoid performance degradation or loss of functionality.

## PIN CONFIGURATION

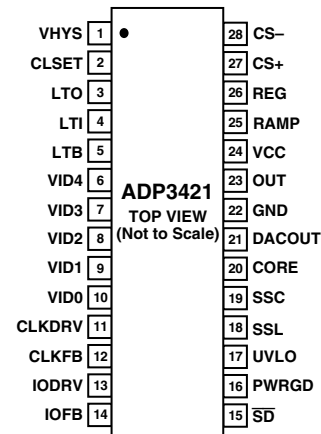

## PIN FUNCTION DESCRIPTIONS

Pin	Mnemonic	Function
1	VHYS	Core Comparator Hysteresis Setting. The voltage at this pin is held at a 1.7 V reference level. A resistor to ground programs at a 1:1 ratio the current that is alternately switched into and out of the RAMP pin.
2	CLSET	Current Limit Setting. The voltage at this pin is held at a 1.7 V reference level. A resistor to ground programs a current that is gained up by 3:1 flowing out of the CS− pin, assuming the current limit comparator is not triggered.
3	LTO	Level Translator Output. This pin must be tied through a pull-up resistor to the voltage level desired for the output high level. That voltage cannot be less than 1.5 V.
4	LTI	Level Translator Input. This pin should be driven from an open drain/collector signal. The pull-up current is provided by the pull-up resistor on the LTO pin. However, the pull-up current will be terminated when the LTI pin reaches 1.5 V.
5	LTB	Level Translator Bypass. For operation of the level translator with high-speed signals, this pin should be bypassed to ground with a large value capacitor.
6	VID4	VID Input. Most significant bit.
7	VID3	VID Input
8	VID2	VID Input
9	VID1	VID Input
10	VID0	VID Input. Least significant bit.
11	CLKDRV	2.5 V Linear Regulator Driver Output. This pin sinks current from the base of a PNP transistor as needed to keep the CLKFB node regulated at 2.5 V.
12	CLKFB	2.5 V Linear Regulator Output Feedback. This pin is connected to the collector of a PNP transistor whose base is driven by the CLKDRV pin.
13	IODRV	1.5 V Linear Regulator Driver Output. This pin sinks current from the base of a PNP transistor as needed to keep the IOFB node regulated at 1.5 V.
14	IOFB	1.5 V Linear Regulator Output Feedback. This pin is connected to the collector of a PNP transistor whose base is driven by the IODRV pin.



Pin	Mnemonic	Function
15	$\overline{SD}$	Shutdown Input. When this pin is pulled low, the IC shuts down and all regulation functions will be disabled.
16	PWRGD	Power Good Output. This signal will go high only when the $\overline{SD}$ pin is high to allow IC operation, the UVLO and VCC pins are above their respective start-up thresholds, the SSC and SSL pins are above a voltage where soft start is completed, and the voltage at the CORE pin is within the specified limits of the programmed VID voltage. By choosing the soft-start capacitor for the core larger than that for the linear regulators, at start-up the core and linear outputs should all be in regulation before PWRGD is asserted.
17	UVLO	Undervoltage Lockout Input. This pin monitors the input voltage through a resistor divider. When the pin voltage is below a specified threshold, the IC enters into UVLO mode regardless of the status of $\overline{SD}$ . When in UVLO mode, a current source is switched on at this pin, which sinks current from the external resistor divider. The generated UVLO hysteresis is equal to the current sink value times the upper divider resistor.
18	SSL	Linear Regulator Soft Start. During power-up, an external soft-start capacitor is charged by a current source to control the ramp-up rates of the linear regulators.
19	SSC	Core Voltage Soft Start. During power-up, an external soft-start capacitor is charged by a current source to control the ramp-up rate of the core voltage.
20	CORE	Core Converter Voltage Monitor. This pin is used to monitor the core voltage for power good verification.
21	DACOUT	VID-Programmed Digital-to-Analog Converter Output. This voltage is the reference voltage for output voltage regulation.
22	GND	Ground
23	OUT	Logic-Level Drive Signal Output of Core Controller. This pin provides the drive command signal to the IN pin of the ADP3410 driver. This pin is not capable of directly driving a power MOSFET.
24	VCC	Power Supply
25	RAMP	Current Ramp Input. This pin provides the negative feedback for the core output voltage. The switched sink/source current from this pin, which is set up at the VHYS pin, works against the terminating resistance at this pin to set the hysteresis for the hysteretic control.
26	REG	Regulation Voltage Summing Input. In the recommended configuration, the DACOUT voltage and the core voltage are summed at this pin to establish regulation with output voltage positioning.
27	CS+	Current Limit Positive Sense. This pin senses the positive node of the current sense resistor.
28	CS-	Current Limit Negative Sense. This pin connects through a resistor to the negative node of the current sense resistor. A current flows out of the pin, as programmed at the CLSET pin. When this pin is more negative than the CS+ pin, the current limit comparator is triggered and the current flowing out of the pin is reduced to two-thirds of its previous value, producing a current limit hysteresis.

# ADP3421—Typical Performance Characteristics

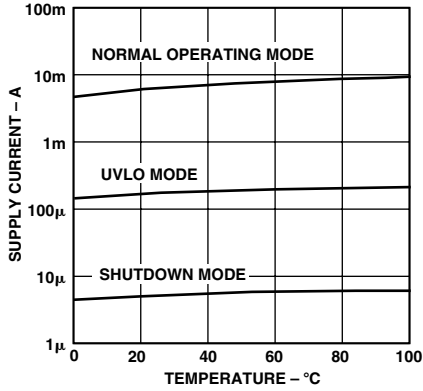

TPC 1. Supply Current vs. Temperature

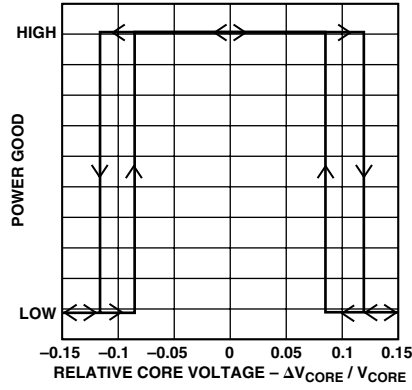

TPC 2. Power Good vs. Relative Core Voltage Variation

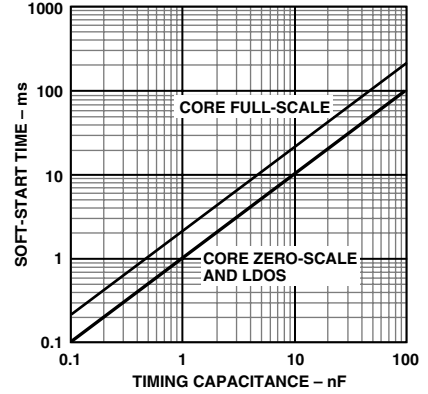

TPC 3. Soft-Start Time vs. Timing Capacitance

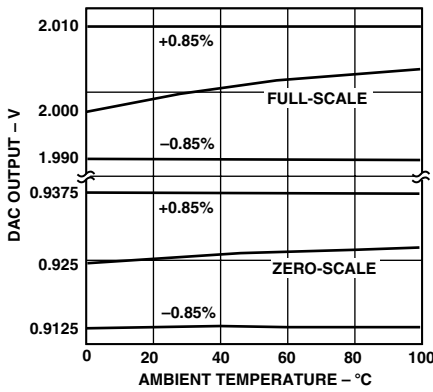

TPC 4. DAC Output Voltage vs. Temperature

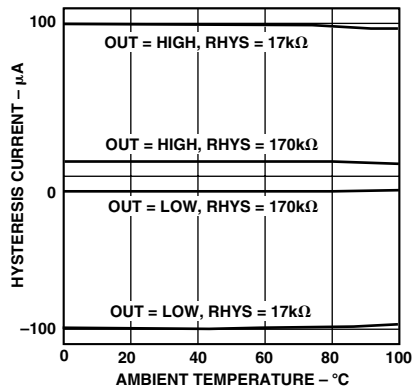

TPC 5. Core Hysteresis Current vs. Temperature

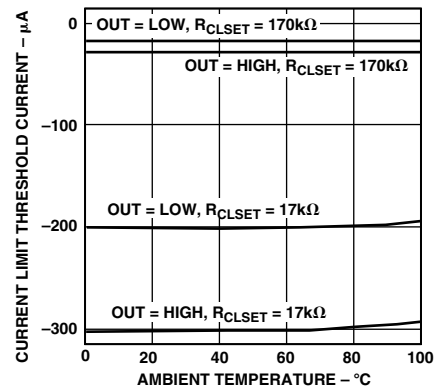

TPC 6. Current Limit Threshold Current vs. Temperature

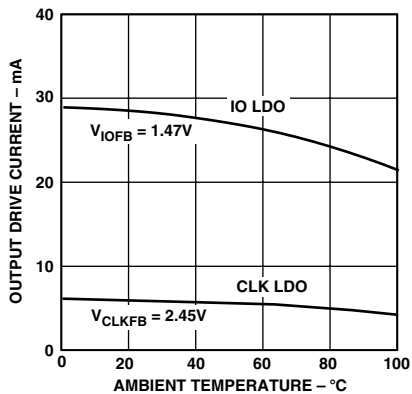

TPC 7. LDO Drive Current vs. Temperature

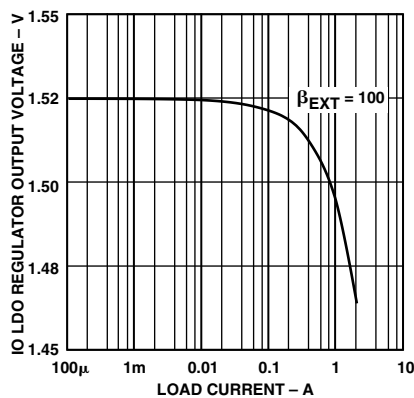

TPC 8. IO LDO DC Load Regulation

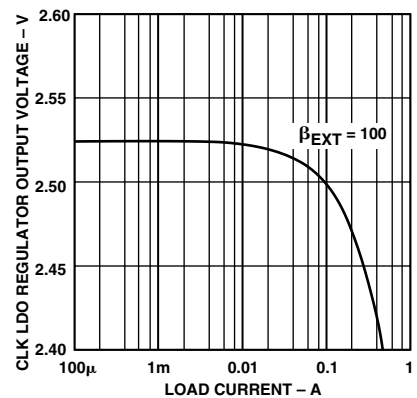

TPC 9. CLK LDO DC Load Regulation

## THEORY OF OPERATION

### Supply Voltages

The ADP3421 is optimized for use with, and specified at a 3.3 V supply, but can operate at up to 6 V at the expense of increased quiescent current and minor tolerance degradation. The ADP3410 MOSFET driver can accommodate up to 30 V for driving the upper power MOSFET to 5 V above a 25 V rail.

### Undervoltage Lockout

The undervoltage lockout (UVLO) circuit comprises the low  $V_{IN}$  and low VCC detection comparators. UVLO for  $V_{IN}$  provides a system UVLO that monitors the battery voltage and allows the converter operation to be disabled if the battery falls below a preset threshold. A resistor divider to the UVLO pin sets the UVLO-off level for the system comparing to a specified reference. When  $V_{IN}$  goes low enough to activate UVLO, this triggers a specified current sink into the pin to be switched on. This raises the UVLO-on threshold above the UVLO-off threshold by the current sink values times the upper resistor of the divider. So the resistor divider ratio at the UVLO pin is used to set the UVLO threshold and the hysteresis.

Hysteresis for the system UVLO is recommended to prevent oscillation due to nonzero battery impedance. If UVLO is triggered during a condition where the battery is loaded by the converter operation, the converter will turn off and the battery voltage will then rise to a slightly higher level. A good design will ensure that the hysteresis is sufficient to prevent the converter from turning on again.

UVLO for VCC provides an internally specified UVLO threshold for the ADP3421 to ensure that it only operates when the applied VCC is sufficient to ensure that it can operate properly.

Activation of either UVLO circuit disables the reference and bias circuits in the IC except for that which is needed for UVLO detection.

### Power Good

If the IC is enabled and is not in the UVLO mode and has finished its soft-start period, and if the core voltage is within  $\pm 10\%$  of the VID programmed value, then a high-level signal appears at the PWRGD pin.

### Power Good During VID Change

When a VID change occurs, the DAC output responds faster than the output voltage, which is slew rate limited by the output filter. In this case, PWRGD may momentarily go low. To avoid system interruption, the PC power management system should not respond to this glitch. The PWRGD signal corresponds to  $V_{GATE}$  as specified in Intel's Geyserville Voltage Regulator specification. The glitch can be masked from the system by using the appropriate system programming settings or by using a functionally equivalent OR gate, which provides a blanking signal for the specified latency period where the core voltage is allowed to settle at its new value. Because of the minimal output capacitor requirement, the response time of the core voltage is well within the specified latency period and, when the power converter is properly compensated, it does not exhibit any overshoot.

### VID-Programmed DAC Reference

This 5-bit digital-to-analog converter (DAC) serves as the programmable reference source of the dc-dc converter. Programming is accomplished by CMOS logic-level VID code

applied to the DAC input. The VID code corresponds to that recommended in guidelines for the mobile Pentium® III published by Intel (see Table I).

**Table I. VID Code**

VID4	VID3	VID2	VID1	VID0	VOUT
0	0	0	0	0	2.000
0	0	0	0	1	1.950
0	0	0	1	0	1.900
0	0	0	1	1	1.850
0	0	1	0	0	1.800
0	0	1	0	1	1.750
0	0	1	1	0	1.700
0	0	1	1	1	1.650
0	1	0	0	0	1.600
0	1	0	0	1	1.550
0	1	0	1	0	1.500
0	1	0	1	1	1.450
0	1	1	0	0	1.400
0	1	1	0	1	1.350
0	1	1	1	0	1.300
0	1	1	1	1	Off*
1	0	0	0	0	1.275
1	0	0	0	1	1.250
1	0	0	1	0	1.225
1	0	0	1	1	1.200
1	0	1	0	0	1.175
1	0	1	0	1	1.150
1	0	1	1	0	1.125
1	0	1	1	1	1.100
1	1	0	0	0	1.075
1	1	0	0	1	1.050
1	1	0	1	0	1.025
1	1	0	1	1	1.00
1	1	1	0	0	0.975
1	1	1	0	1	0.950
1	1	1	1	0	0.925
1	1	1	1	1	Off*

\*No CPU shutdown

### Core Comparator

The core comparator is an ultrafast hysteretic comparator with a typical propagation delay to the OUT pin of 15 ns at a 20 mV overdrive.

This comparator is used with a switched hysteresis current for controlling the main feedback loop, as described in the Main Feedback Loop Operation section. This comparator has no relation to the CORE pin, which is used only for core voltage monitoring for the PWRGD function.

### Current Limit Comparator

The current limit comparator monitors the voltage across the current-sense resistor  $R_{CS}$  and it overrides the core comparator and forces the OUT pin to low when the current exceeds the peak current limit threshold. The current control is hysteretic, with a valley current threshold equal to two-thirds of the peak current limit threshold. When the sensed current signal falls to two-thirds of the peak threshold, the OUT pin is allowed to go high again, and the control of the main loop reverts back to the core comparator.

# ADP3421

A resistor ( $R_{CLS}$ ) connected between the CLSET and ground sets a current that is internally multiplied by a factor of three and flows out of the CS $-$  pin. The resistor  $R_{CL}$  connected in series with the CS $-$  pin to the negative current sense point (i.e., the output voltage) sets the voltage that must be developed across  $R_{CS}$  to trip the current limit comparator. Once it is tripped, the CS $-$  current is scaled down by two-thirds, so the inductor current must ramp down accordingly to reset the comparator.

## Core Converter Soft-Start Timer

The soft-start function limits the ramp-up time of the core voltage in order to reduce the initial in-rush current on the core input voltage (battery) rail. The soft-start circuit consists of an internal current source, an external soft-start timing capacitor, an internal switch across the capacitor, and a comparator monitoring the capacitor voltage.

The soft-start capacitor is held discharged when either the  $\overline{SD}$  signal is low or the device is in UVLO mode. As soon as  $\overline{SD}$  is set to high, and VCC and  $V_{IN}$  rise above their respective UVLO thresholds, the short across the external timing capacitor is removed, and the internal soft-start current source begins to charge the timing capacitor. During the charge of the soft-start capacitor, the Power Good signal is set to low. When the timing capacitor voltage reaches an internally set soft-start termination threshold, the core monitor window comparator output is enabled, allowing the Power Good status to be determined. If the core voltage has already settled within the specified limits the Power Good signal goes high, otherwise it stays low. The soft-start capacitor remains charged until either  $\overline{SD}$  goes low, or VCC or  $V_{IN}$  drop below their respective UVLO thresholds. When this occurs, an internal switch quickly discharges the soft-start timing capacitor to prepare the IC for a new start-up sequence.

## Soft-Start Restart Lock In

In the event that a UVLO event was not long enough to allow the soft-start capacitors to discharge (e.g., a momentary power glitch), the UVLO event is captured by a latch. The forced discharge of the soft-start capacitors will continue until a lower threshold is reached, at which time the converter will restart with a fully controlled soft start.

## 1.5 V I/O Voltage Regulator

Two pins control an external PNP, for example, transistor as a linear regulator for a 1.5 V output. The IODRV pin directly drives the base of the PNP with  $\geq 10$  mA to support an output current as high as the PNP's current gain and power dissipation capability will allow. For example, with a high gain PNP transistor such as the Zetex ZFT788B (SOT-223), the I/O linear regulator is capable of delivering peak currents of greater than 2.5 A. The 1.5 V output is connected to the IOFB pin to provide feedback.

## 2.5 V CLK LDO Voltage Regulator

Two pins control an external PNP transistor as a linear regulator for a 2.5 V output. The CLKDRV pin, for example, directly drives the base of the PNP with  $\geq 3$  mA to support an output current as high as the PNP's current gain and power dissipation capability will allow. For example, with a high gain PNP transistor such as the Zetex ZFT788B (SOT-223), the CLK linear regulator is capable of delivering peak currents of greater than 1.2 A. The 2.5 V output is connected to the CLKFB pin to provide feedback.

## Linear Regulator Soft-Start Timer

The soft-start timer circuit of the linear regulators is similar to that of the core converter, and is used to control the ramp-up

time of the linear regulator output voltages. For maximum flexibility in controlling the start-up sequence, the soft-start function of the linear regulators was separated from that of the core converter.

## Level Translator

The level translator converts any digital input signal to a user-programmable voltage level. This can be used to translate an IO-level signal (i.e., 1.5 V) into a CLK-level or VCC-level or even 5 V-level signal. For example, the 1.5 V FERR# signal can be converted to a 3.3 V level for the PII-X4 chipset. The output signal is in phase with the input, and it is not necessary to have a pull-up on the input signal. The ADP3421 provides pull-up for the input signal to 1.5 V. The only practical restriction on the input signal is that it must not prevent pull-up to 1.5 V. An external pull-up resistor sets the output signal level. Throughput time for the signal using a 150  $\Omega$  pull-up resistor is 5 ns (typ).

## APPLICATION INFORMATION

### Overview—Combined ADP3421 and ADP3410 Power Controller for PC Systems

The ADP3421 is a power controller that can provide a regulation solution for all three power rails of an Intel Pentium II or III processor. Together with the ADP3410 driver IC, these ICs form an integral part of a PC system, featuring a high-speed ( $< 10$  ns) level translator, interface with GCL and PII-X4 or other power management signals, and a power sequenced switched 5 V rail. For high-slew-rate microprocessors, this minimizes the total solution cost by allowing the quantity of output capacitors to be minimized to the limit of what the buck converter topology and the capacitor technology can allow.

### Recommended Configuration

The ADP3421 controls the regulation of the core voltage without amplifiers in a unique ripple regulator control topology. In a proprietary optimized compensation configuration offered by Analog Devices, Inc., the inductor ripple current is kept at a fixed programmable value while the output voltage is regulated with fully programmable voltage positioning parameters, which can be tuned to optimize the design for any particular CPU regulation specifications. By fixing the ripple current, the frequency variations associated with changes in output capacitance and ESR for standard ripple regulators will not appear.

Accurate current sensing is needed to accomplish accurate output voltage positioning, which, in turn, is required to allow the minimum number of output capacitors to be used to contain transients. A current-sense resistor is used between the inductor and the output capacitors. To allow the control to operate without amplifiers, the negative feedback signal is taken from the inductor, or upstream, side of the current-sense resistor, and the positive feedback signal is taken from the downstream side.

Active voltage positioning, whose advantages are described later, has two parameters that are separately controlled. The negative feedback signal uses a resistor divider to ground into the RAMP pin to create the precise *offset* voltage needed for voltage positioning. The positive feedback signal and the DAC's VID-controlled reference are summed into the REG pin through resistors to set the desired voltage positioning *gain*. The *proprietary optimal compensation* is a final parameter that must be tuned to ensure that the voltage positioning is not bandwidth limited. This is accomplished by using the appropriately-sized capacitor in parallel with the resistor that sums the positive feedback signal. The



optimal compensation also gives the ripple current control that adds stability to the switching frequency.

#### Standard Hysteretic Control Configuration

The ADP3421 can also be used as a conventional hysteretic ripple regulator where the output ripple voltage is directly programmed. To achieve this conventional operation, the DAC's output is connected directly to the REG pin and the output voltage connects through a resistor to the RAMP pin. This resistor sets the output ripple voltage, which will be symmetrically centered around the DAC voltage. If the optimal DAC voltage is not available, an offset could be summed into the RAMP pin with another resistor, as was done with the previous configuration.

#### Intel Mobile Voltage Positioning Implementation

In the recommended configuration, the ADP3421 uses voltage Intel Mobile Voltage positioning technology as an inherent part of its architecture.

No matter how fast the response of the switches, even instantaneous, the inductor limits the response speed at the output of the converter. This places the primary burden of transient response containment on the output capacitors. The size and cost of the output capacitors can be minimized by keeping the output voltage higher at light load in anticipation of a load increase, and lowering the output voltage at heavier loads in anticipation of a load decrease. Voltage positioning with the ADP3421 is active, which means the voltage positioning can be controlled by loop gain. This increases efficiency compared to passive voltage positioning that is sometimes used as a supplementary regulation technique with voltage-mode controllers. Instead of sizing a series resistor to create the entire voltage drop (often called a “droop” resistor in the passive voltage positioning implementation), a smaller value current-sensing resistor can be used and the loop can amplify its voltage drop to position the voltage as desired without additional power loss.

#### Voltage Positioning for Power Savings

In addition to the size and cost reduction of the output capacitors, another advantage of using voltage positioning is a reduction in the CPU core dissipation. That dissipation is equal to the product of the applied core voltage and the current drawn by the CPU. The CPU current is primarily due to the capacitive switching load of digital circuitry, and it is also proportional to the applied voltage. The result is that the CPU power dissipation is approximately proportional to the applied voltage squared.

$$P_{CPU} = k \times V_{CPU}^2$$

This characteristic, combined with the wide tolerance on the core voltage specification, suggests that the maximum CPU power dissipation can be substantially reduced by setting the core voltage near the lower specified voltage limit. For example, if a 1.6 V processor is operated 7% below its nominal voltage rating, the CPU power dissipation is reduced by 13.5%. Losses in the switches and inductor of the power converter are also reduced due to the decrease in maximum load current.

To realize the full cost-reducing benefits of active voltage positioning, a current-sensing resistor should be used to convey accurate current information to the control loop. This is needed to accurately position the core voltage as a function of load current. Accurate positioning of the core voltage allows the highest reduction in output capacitors. It is common to see passive voltage positioning implemented by sensing voltage drop on a copper trace or across a power MOSFET. This causes poor control of the

voltage positioning—a tolerance analysis can show the weakness of this design technique.

Although additional power is dissipated by the current-sense resistor, the total power consumption is reduced because of the squared reduction of current consumption by the CPU. For example, if the CPU draws 15 A at 1.6 V, the current-sensing resistor is 3 mΩ, and the supply voltage is reduced by 7%, the core dissipation can be reduced from 24 W to:

$$24 \text{ W} \times 0.93^2 = 20.76 \text{ W},$$

and the power dissipated in the resistor is only:

$$[20.76 \text{ W} / (1.6 \text{ V} \times 0.93)]^2 \times 3 \text{ m}\Omega = 0.58 \text{ W}.$$

The total power savings from the battery is 2.65 W, or 11.1%.

#### Optimally Compensated for Voltage Positioning

Although voltage positioning helps to control the initial load transient, high-frequency load repetition rates can cause the voltage to exceed by double the limits within which the transients can be contained. For complete transient containment over the bandwidth of the core's transient activity, the solution is an enhanced optimally compensated version of voltage positioning.

It prevents the tendency of the core voltage to “bounce” before settling to its final positioned value after the inductor current has been ramped to its final value.

#### Main Feedback Loop Operation

In conjunction with a selected control topology, the ADP3421 regulates a drive control signal at the OUT pin using a comparator. The two inputs are pins RAMP (–) and REG (+). A bidirectional switched control current is used at the RAMP input to establish hysteresis with a chosen termination resistance. Beginning in the drive high state (OUT pin high), the control current is sinking current into the RAMP pin, but the output current in the buck converter is increasing and so  $V_{RAMP}$  will eventually exceed  $V_{REG}$ . When this happens, the control current reverses and sources current out of the RAMP pin to provide both hysteresis and overdrive for the comparator. The OUT pin goes low and the buck converter output current decreases until  $V_{RAMP} < V_{REG}$ , at which time the comparator switches, the control current reverses, and the process repeats.

How the hysteresis current is used (depending on the control configuration) will determine which parameter is hysteretically controlled—presumably either the inductor ripple current or the output ripple voltage, as in the two suggested configurations, or a weighted combination of the two or another variable could be introduced.

#### Core Converter Design Procedure

There are two primary objectives considered in optimizing the design of a power converter. The first objective is to meet the specifications; the second objective is to do so at the lowest cost. Analog Devices, Inc., addresses both of these objectives with the ADP3421 and its recommended design procedure. The optimized design yields the additional benefit of reducing the maximum CPU power consumption by ~10% for typical CPU specifications, which has created great interest in those using the CPU.

Microprocessors have the distinguishing characteristic of creating extremely fast load transients from nearly zero to the maximum load and vice versa. The advent of increasing power management (used to interrupt the CPU processing) causes

# ADP3421

these transients to occur with increasing frequency. Since it takes a far longer time (typically on the order of several microseconds) to ramp the inductor current up or down to the correct average value after a load transient has occurred, the output capacitors must supply or absorb the extra charge during that period of time. This causes the output voltage to dip down or peak up.

To contain the output voltage within the specified limits during load transients, with the minimum quantity of output capacitors, the output voltage must be positioned as a function of load, and it must be done so accurately. Therefore, current-sensing with a discrete resistor (rather than trace resistance) is strongly recommended, because it allows the number of capacitors to be reduced toward the theoretical minimum—which is nearly half as many as required for a standard fixed-regulation technique. This is the key to minimizing the cost (and size) of the power converter.

The voltage should be positioned (i.e., regulated) high at no load and low at maximum load. This means that the power supply will appear to have an initial offset and reduced load regulation, because the output voltage will regulate higher than nominal at no load and below nominal at maximum load. This regulation technique positions the voltage in anticipation of a load transient. At no load, the voltage is high, so when the load transient strikes, the downward dip can be more easily contained within the limits. Similarly at maximum load, the voltage is low, so when the load transient strikes, the upward peak can be more easily contained.

Multiple MLC capacitors will always be needed on the output across the CPU power pins to handle the high-frequency component of the transient with minimized series inductance to and through the bulk capacitors of the power converter's output filter. Although there are numerous trade-offs between size and cost of various combinations of capacitor types for meeting a given specification, the accurate voltage positioning provided by the ADP3421 will allow the overall combination of capacitors to be minimized.

A key requirement for optimizing the dynamic performance of a power converter with accurate voltage positioning is to apply “optimal compensation”—that is, the compensation that creates a loop response that causes the output voltage to settle immediately after a load transient, resulting in a “flat” transient response. The ADP3421's unique architecture is designed to accommodate this ADI proprietary optimal compensation technique in core dc-dc converters for Mobile CPUs. It is implemented by creating the proper frequency response characteristic at the summing junction of the output voltage and the DAC voltage, which occurs at the REG pin.

The complete design procedure is supplied in a separate application note from Analog Devices, Inc., entitled: DC-DC Power Converter Design using the ADP3421 Controller.

## PRINTED CIRCUIT BOARD LAYOUT CONSIDERATIONS

The ADP3421 is a high-speed controller capable of providing a response time well under 100 ns. To avoid having the ADP3421 respond to noise, the first step in achieving good noise immunity is to follow the layout considerations.

In some layouts it may be necessary to supplement the ADP3421 control design with additional components designed to minimize noise problems. For this purpose, some additional hysteresis can be added around the core and current limit comparators. This takes the form of adding a small capacitor (~1 pF) from OUT to REG (for the main loop) and OUT to CS- (for current limit loop), and providing some resistance for the capacitive hysteresis feedback to work against. For the current limit loop, this resistor is already in the basic circuit. For the main loop, this resistor must be added between the REG pin and the standard feedback components. This provides a quick dynamic hysteresis with a small time constant that is chosen only long enough to ensure that the switching noise ringing through the circuit has decayed by the time the dynamic hysteresis is substantially lost.

The following guidelines are recommended for optimal performance of the ADP3421 and ADP3410 in a power converter. The circuitry is considered in four parts: the power switching circuitry, the output filter, the control circuitry, and the LDOs.

### Placement Overview

1. For ideal component placement, the output filter capacitors will divide the power switching circuitry from the control section. As an approximate guideline, considered on a single-sided PCB, the best layout would have components aligned in the following order: ADP3410, MOSFETs and input capacitor, output inductor, current-sense resistor, output capacitors, control components, and ADP3421. Note that the ADP3421 and ADP3410 are completely separated for an ideal layout, which is only possible with a two-chip solution. This will minimize jitter in the control caused by having the driver and MOSFETs close to the control and give more freedom in the layout of the power switching circuitry.
2. Whenever a power dissipating component (e.g., a power MOSFET) is soldered to a PCB, the liberal use of vias, both directly on the mounting pad and immediately surrounding it, is recommended. Two important reasons for this are: improved current rating through the vias (if it is a current path) and improved thermal performance—especially if the vias extend to the opposite side of the PCB where a plane can more readily transfer heat to air.

**Power Switching Circuitry****ADP3410, MOSFETs, Input Capacitors**

3. Locate the ADP3410 near the MOSFETs so the parasitic inductance in the gate drive traces and the trace to the SW pin is small, and so that the ground pins of the ADP3410 are closely connected to the lower MOSFET's source.
4. Locate at least one substantial (i.e.,  $> \sim 1 \mu\text{F}$ ) input bypass MLC capacitor close to the MOSFETs so that the physical area of the loop enclosed in the electrical path through the bypass capacitor and around through the top and bottom MOSFETs (drain-source) is small. This is the switching power path loop.
5. Make provisions for thermal management of all the MOSFETs. Heavy copper and wide traces to ground and power planes will help to pull out the heat. Heat sinking by a metal tap soldered in the power plane near the MOSFETs will help. Even just small airflow can help tremendously. Paralleled MOSFETs will help spread the heat, even if the on resistance is higher.
6. An external "antiparallel" Schottky diode (across the bottom MOSFET) may help efficiency a small amount ( $< \sim 1\%$ ); a MOSFET with a built-in antiparallel Schottky is more effective. For an external Schottky, it should be placed next to the bottom MOSFET or it may not be effective at all. Also, a higher current rating (bigger device with lower voltage drop) is more effective.
7. Both ground pins of the ADP3410 should be connected into the same ground plane with the power switching circuitry, and the VCC bypass capacitor should be close to the VCC pin and connected into the same ground plane.

**Output Filter****Output Inductor and Capacitors, Current-Sense Resistor**

8. Locate the current-sense resistor very near to the output capacitors.
9. PCB trace resistances from the current-sense resistor to the output capacitors, and from the output capacitors to the load, should be minimized, known (calculated or measured), and compensated for as part of the design if it is significant. (Remote sensing is not sufficient for relieving this requirement.) A square section of 1 ounce copper trace has a resistance of  $\sim 500 \text{ m}\Omega$ . Using 2-3 squares of copper can make a noticeable impact on a 15 A design.
10. Whenever high currents must be routed between PCB layers, vias should be used liberally to create several parallel current paths so that the resistance and inductance introduced by these current paths is minimized and the via current rating is not exceeded.
11. The ground connection of the output capacitors should be close to the ground connection of the lower MOSFET and it should be a ground plane. Current may pulsate in this path if the power source ground is closer to the output capacitors than the power switching circuitry, so a close connection will minimize the voltage drop.

**Control Circuitry****ADP3421, Control Components**

12. If the placement overview cannot be followed, the ground pin of the ADP3421 should be Kelvin-connected into the ground plane near the output capacitors to avoid introducing ground noise from the power switching stage into the control circuitry. All other control components should be grounded on that same signal ground.
13. If critical signal lines (i.e., signals from the current-sense resistor leading back to the ADP3421) must cross through power circuitry, it is best if a signal ground plane can be interposed between those signal lines and the traces of the power circuitry. This serves as a shield to minimize noise injection into the signals at the expense of making signal ground a bit noisier.
14. Absolutely avoid crossing any signal lines over the switching power path loop, as previously described.
15. Accurate voltage positioning depends on accurate current sensing, so the control signals that differentially monitor the voltage across the current-sense resistor should be Kelvin-connected.
16. The RC filter used for the current-sense signal should be located near the control components.

**LDOs****PNP Transistors**

17. The maximum steady-state power dissipation expected for the design should be calculated so that an acceptable package type PNP for each output is selected and properly mounted to be able to dissipate the power with acceptable temperature rise.
18. Each PNP transistor should be located close to the load that it sources.
19. The supply voltage to the PNP emitters should be low impedance to avoid loop instability. It is good design practice to have at least one MLC capacitor near each of the PNP emitters to help ensure the impedance is sufficiently low.

# ADP3421

## TYPICAL APPLICATION—GEYSERVILLE-ENABLED MOBILE VRM CONVERTER

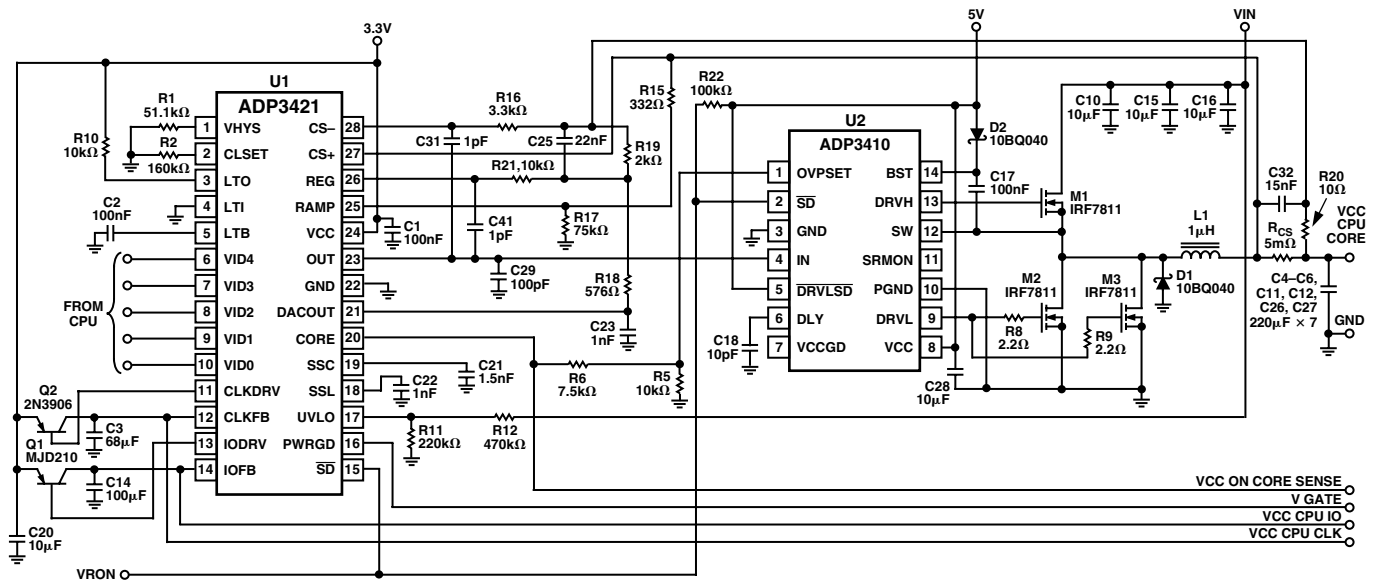
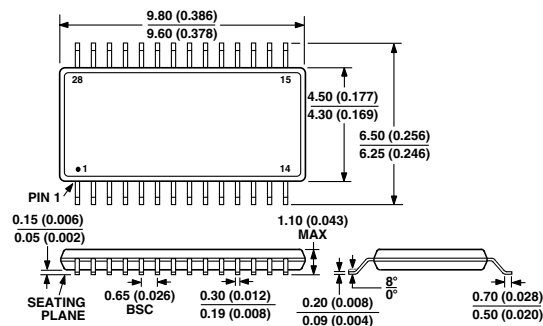

Figure 1. Mobile VRM Schematic

### OUTLINE DIMENSIONS

Dimensions shown in mm and (inches).

#### 28-Lead Thin Shrink Small Outline Package (TSSOP) (RU-28)



CONTROLLING DIMENSIONS ARE IN MILLIMETERS; INCH DIMENSIONS (IN PARENTHESES) ARE ROUNDED-OFF MILLIMETER EQUIVALENTS FOR REFERENCE ONLY AND ARE NOT APPROPRIATE FOR USE IN DESIGN

## Revision History

Location

Page

5/02—Data Sheet changed from REV. 0 to REV. A.

Changed Figures to TPCs ..... 6

Renumbered Figure ..... 12