

MC10SX1130

LED Driver

Description

The MC10SX1130 is high speed LED Driver/current switch specifically targeted for use in FDDI PMD and ANSI X3T9.3 FibreChannel 266 Mbits/s optical transmitters. The integrated circuit contains several unique functional blocks which makes it easily configurable for use with a variety of high performance LED devices. The part is fabricated using MOSAIC III™ bipolar process. The logic is designed so that a data HIGH input results in the modulation current flowing through the I_{OUT} pin to turn on the LED.

The device incorporates open collector outputs with a capability of driving peak currents of 100 mA. Since the output current switching circuitry simply switches current between the complementary outputs, the dynamic switching demands on the system power supply are greatly reduced. In addition, because the design is pure bipolar, the device current drain is insensitive to the data pattern and frequency of operation.

The LED drive current is adjustable through the selection of an external set resistor, RSET. In addition, to allow for open loop compensation for the LED's negative optical output power tracking over temperature, a circuit is included to provide an adjustable positive temperature tracking coefficient to the LED drive current. This is controlled through the selection of an external resistor, RTCO.

The MC10SX1130 incorporates novel pulse stretching circuitry which is intended to compensate for the turn-on delay and rise and fall time asymmetry inherent in LED devices. The stretch circuitry can be used to pre-distort the input signal pulse width to minimize the duty cycle distortion of the transmitted optical eye pattern. The stretch circuitry supports three different selections of pre-distortion. This choice is accomplished through a unique 'tri-state' input which can be left open, tied to V_{CC}, or tied to V_{EE} to determine the pre-distortion amount.

The device provides a V_{BB} output for either single-ended use or as a DC bias for AC coupling the signal into the device. The V_{BB} pin should only be used as a bias for the MC10SX1130 as its current sink/source capability is limited. Whenever used, the V_{BB} pin should be bypassed to ground via a 0.01 μF capacitor.

Features

- Differential Data Inputs
- 300 MHz Operation
- 100 mA Peak Drive Current
- Extremely Low Jitter
- Duty Cycle Distortion Compensation
- Adjustable Output Current Tracking With Temperature
- Thermally Enhanced 16-Lead SOIC Package
- 75 kΩ Data Input Pulldown Resistors
- +5 V or -5.2 V Operation
- V_{BB} Reference Available
- Pb-Free Packages are Available*

*For additional information on our Pb-Free strategy and soldering details, please download the ON Semiconductor Soldering and Mounting Techniques Reference Manual, SOLDERRM/D.



ON Semiconductor®

<http://onsemi.com>

LED DRIVER

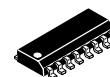

SOIC-16
D SUFFIX
CASE 751B

MARKING DIAGRAM

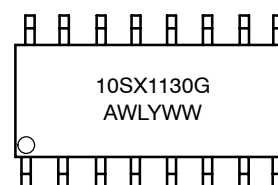

A = Assembly Location
WL = Wafer Lot
Y = Year
WW = Work Week
G = Pb-Free Package

ORDERING INFORMATION

See detailed ordering and shipping information in the package dimensions section on page 8 of this data sheet.

MC10SX1130

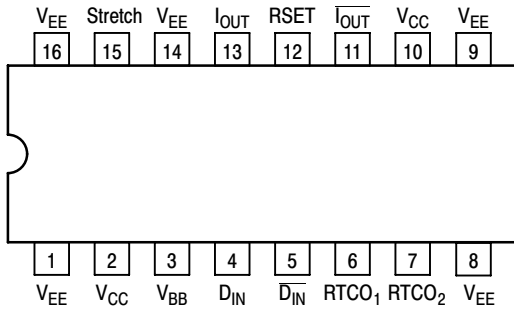

Figure 1. Pinout: SOIC-16
(Top View)

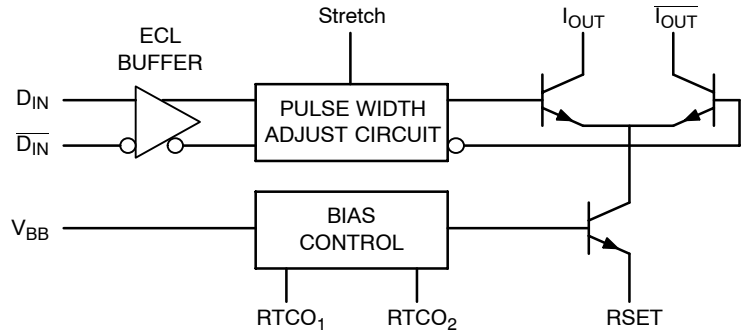

Figure 2. Block Diagram

Table 1. PIN FUNCTION TABLE

Pin	Function
D _{IN}	Differential data inputs.
I _{OUT}	Differential open collector outputs.
STRETCH	Control input to select the amount of duty cycle pre-distortion. When the pin is left open, no pre-distortion is introduced. If the pin is connected to V _{CC} , the output LOW state current pulse width is increased by 155 ps. When it is connected to V _{EE} , the current pulse width is increased by 310 ps.
RSET	Resistor to set LED drive current. This resistor sets the tail current of the output current switch and should be connected to the V _{EE} plane. Since the RSET voltage compensation circuit is referenced to V _{EE} , the RSET voltage will track 1:1 with V _{EE} changes, thus the voltage across the RSET resistor will remain constant.
RTCO ₁ , RTCO ₂	Terminals for positive temperature tracking resistor. This resistor controls the temperature tracking rate of the voltage at the RSET pin, which in turn sets the LED drive current tracking. If the two pins are shorted together, the nominal tracking rate is 1.4mV/°C and when a 2 kΩ resistor is connected across the pins, the nominal tracking rate is 4.9 mV/°C.
V _{CC}	Most positive power supply input. +5 V for PECL operation or ground for standard ECL operation.
V _{EE}	Most negative power supply input. Ground for PECL operation or -5.2 V for standard ECL operation.
V _{BB}	Reference voltage for use in single ended applications or when the input signal is AC coupled into the device.

MC10SX1130

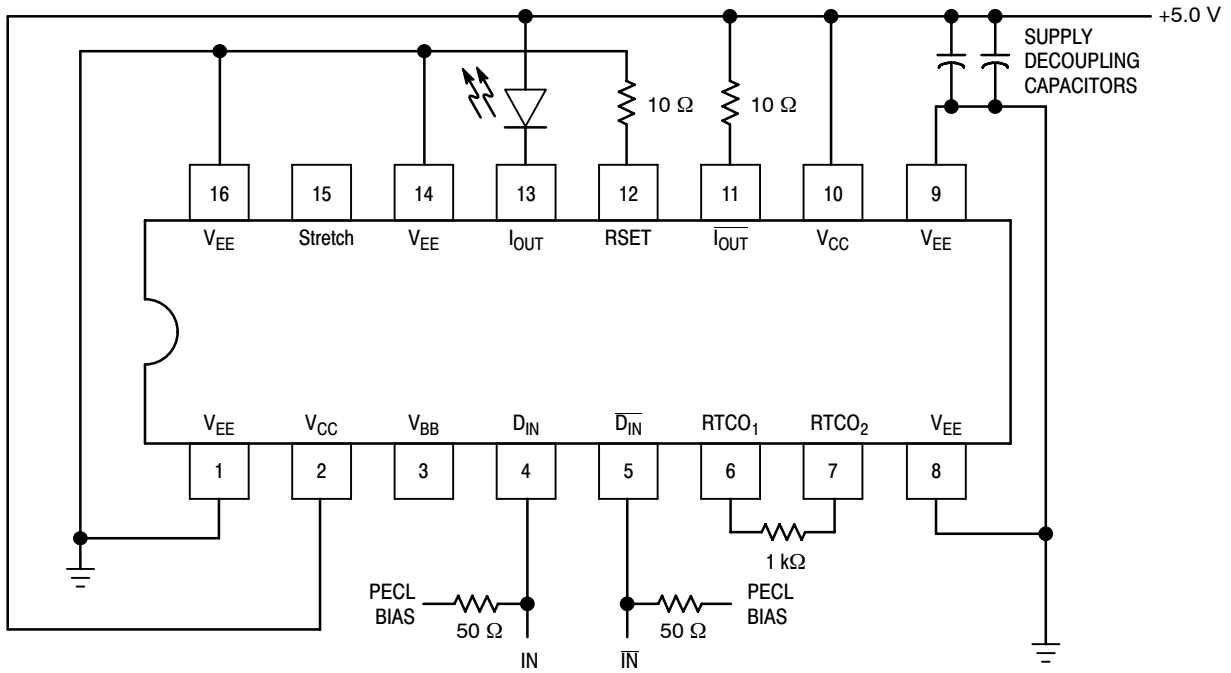

Figure 3. Typical +5 V Applications Circuit

Table 2. ABSOLUTE MAXIMUM RATINGS

Symbol	Parameter	Value	Unit
V_{EE}	Power Supply ($V_{CC} = 0$ V)	-7.0 to 0	VDC
V_I	Input Voltage ($V_{CC} = 0$ V)	0 to -6.0	VDC
I_{out}	Output Current Continuous Surge	100 110	mA
T_A	Operating Temperature Range	-40 to +85	°C
V_{EE}	Operating Range ($V_{CC} = 0$)	-5.5 to -4.5	VDC

Maximum ratings are those values beyond which device damage can occur. Maximum ratings applied to the device are individual stress limit values (not normal operating conditions) and are not valid simultaneously. If these limits are exceeded, device functional operation is not implied, damage may occur and reliability may be affected.

MC10SX1130

Table 3. DC CHARACTERISTICS (RTCO = 1 k Ω \pm 5%, R_{SET} = R at I_{OUT} = R at I_{OUT} = 10 Ω \pm 1%, Unless Otherwise Noted)(Note 1)

Symbol	Characteristic	-40°C			0°C			25°C			85°C			Unit
		Min	Typ	Max	Min	Typ	Max	Min	Typ	Max	Min	Typ	Max	
I _{IH}	Input HIGH Current (DIN, $\overline{\text{DIN}}$ Pins)			200			200			200			200	μ A
I _{IL}	Input LOW Current (DIN, $\overline{\text{DIN}}$ Pins)	0.5			0.5			0.5			0.5			μ A
I _{CC}	Quiescent Supply Current (No Load on RSET Pin)	12	17	24	12	17	24	12	18	24	12	19	24	mA
V _{IH}	Input HIGH Voltage (Note 2) V _{CC} = 5.0V, V _{EE} = GND V _{CC} = GND, V _{EE} = -4.5 to -5.5V	3770 -1230		4110 -890	3830 -1170		4160 -840	3870 -1130		4190 -810	3940 -1060		4280 -720	mV
V _{IL}	Input LOW Voltage (Note 2) V _{CC} = 5.0V, V _{EE} = GND V _{CC} = GND, V _{EE} = -4.5 to -5.5 V	3050 -1950		3500 -1500	3050 -1950		3520 -1480	3050 -1950		3520 -1480	3050 -1950		3555 -1445	mV
V _{BB}	Output Reference Voltage (Note 2) V _{CC} = 5.0 V, V _{EE} = GND V _{CC} = GND, V _{EE} = -4.5 to -5.5 V	3570 -1430		3700 -1300	3620 -1380		3730 -1270	3650 -1350		3750 -1250	3690 -1310		3810 -1190	mV
V _{SET}	Output Voltage at RSET Pin V _{CC} = 5.0 V RTCO = Short V _{EE} = GND RTCO = 1 k Ω RTCO = 2 k Ω V _{CC} = GND (Note 3) RTCO = Short V _{EE} = -5.2 V RTCO = 1 k Ω RTCO = 2 k Ω		600			635		610	690	770		775		mV
			430			515		570	650	730		855		
			230			355		470	550	630		845		
			-4400			-4365		-4390	-4310	-4230		-4225		
			-4570			-4485		-4430	-4350	-4270		-4145		
			-4770			-4645		-4530	-4450	-4370		-4155		
I _{Oon}	Output 'ON' Current (I _{OUT} , $\overline{\text{IOUT}}$ Pins)	30		75	30		75	30		75	30		100	mA
I _{Ooff}	Output 'OFF' Current (I _{OUT} , $\overline{\text{IOUT}}$ Pins)			50			50			50			50	μ A
V _{TR}	V _{SET} Tracking (Note 4) Short Between RTCO1 and RTCO2 1 k Ω Between RTCO1 and RTCO2 2 k Ω Between RTCO1 and RTCO2		1.4			1.4			1.4			1.4		mV/°C
			3.4			3.4			3.4			3.4		
			4.9			4.9			4.9			4.9		

NOTE: Device will meet the specifications after thermal equilibrium has been established when mounted in a test socket or printed circuit board with maintained transverse airflow greater than 500 lfm. Electrical parameters are guaranteed only over the declared operating temperature range. Functional operation of the device exceeding these conditions is not implied. Device specification limit values are applied individually under normal operating conditions and not valid simultaneously.

- 10SX circuits are designed to meet the DC specifications shown in the table after thermal equilibrium has been established. The circuit is mounted in a test socket or mounted on a printed circuit board and transverse air greater than 500 lfm is maintained.
- Note that in PECL applications, V_{IH}, V_{IL}, V_{BB} will vary 1:1 with the V_{CC} supply.
- V_{SET} tracks 1:1 with the V_{EE} supply to maintain the same voltage across the RSET resistor.
- V_{TR} tracking measures the rate of change of the V_{SET} voltage over temperature.

MC10SX1130

Table 4. AC CHARACTERISTICS (RTCO = 1 k Ω \pm 5%, RSET = R at I_{OUT} = R at I_{OUT} = 10 Ω \pm 1%, Unless Otherwise Noted) (Note 5)

Symbol	Characteristic	Condition	-40°C			0 to 85°C			Unit
			Min	Typ	Max	Min	Typ	Max	
t _{PLH} , t _{PHL}	Propagation Delay (Differential) to Output (Single-Ended)			1300 1300		1000 950	1400 1400	1800 1850	ns
t _{Stretch}	Propagation Delay Stretch = OPEN Stretch = V _{CC} Stretch = V _{EE}	(Note 6)		0 145 300		120 250	0 155 310	200 380	ps
t _r 10-90 t _f 90-10	Rise Time Fall Time	10% to 90% 90% to 10%		600 375		510 330	880 550	1260 860	ps
t _r 20-80 t _f 80-20	Rise Time Fall Time	20% to 80% 80% to 20%		490 260		360 220	600 500	850 750	ps
Jitter	Jitter Square Wave Input Pseudo Random Input	(Note 7) (Note 8)		9 10			6 15		ps
BW	Bandwidth		300	400		300	400		MHz
t _{SKEW}	Duty Cycle Skew (Differential)	(Note 9)		\pm 30			\pm 30		ps
V _{PP}	Minimum Input Swing	(Note 10)	150			150			mV
V _{CMR}	Common Mode Range	(Note 11)	-0.400		See 7	-0.400		See 7	V

NOTE: Device will meet the specifications after thermal equilibrium has been established when mounted in a test socket or printed circuit board with maintained transverse airflow greater than 500 lfm. Electrical parameters are guaranteed only over the declared operating temperature range. Functional operation of the device exceeding these conditions is not implied. Device specification limit values are applied individually under normal operating conditions and not valid simultaneously.

5. 10SX circuits are designed to meet the AC specifications shown in the table after thermal equilibrium has been established. The circuit is mounted in a test socket or mounted on a printed circuit board and transverse air greater than 500 lfm is maintained.
6. When the Stretch function is used, the output low pulse width is increased by the specified amount.
7. Test condition uses a 133 MHz 50% duty cycle signal.
8. Test condition uses a 266 Mbit/s input pseudo-random data stream (n = 23).
9. Duty cycle skew is the difference between t_{PLH} and t_{PHL} propagation delay through a device, Stretch input is left open.
10. Minimum input swing for which AC parameters are guaranteed.
11. The CMR range is referenced to the most positive side of the differential input signal. Normal operation is obtained if the HIGH level falls within the specified range and the peak-to-peak voltage lies between V_{PP Min} and 1.0 V. The lower end of the CMR range is dependent on V_{EE} and is equal to V_{EE} + 3.5 V.

APPLICATIONS INFORMATION

Introduction

The MC10SX1130 is intended to be integrated into high performance fiber optic modules or used stand-alone to drive a packaged optical LED device. The wide frequency response of the device allows it to be used to support a variety of digital communication applications ranging from:

- OC1/3 SONET/SDH Links
- 100 MBit/s FDDI
- 155 MBit/s ATM
- 133/266 MBit/s FibreChannel

To support such wide ranging application areas, the LED Driver incorporates a variety of unique features. These offer designers added flexibility that could not previously be realized in less integrated designs.

LED Characteristics

LED devices emit light when forward biased. The optical power emitted by an LED is determined by the amount of current flowing through the device. This relationship is a relatively linear function of the current, until the device saturates. In some ways, an LED device behaves much like a traditional small signal silicon diode, although the forward “ON” voltage of an LED is much larger and ranges from 1.0 V to 2.0 V. In addition, for a fixed amount of current, the optical power from the LED will decrease if the device junction temperature increases. Another behavior of most LED devices is that they have unequal turn-on and turn-off times. In developing an LED transmitter, the designer must wrestle with all these behaviors to develop a product that meets the design targets.

LED Driver

The MC10SX1130 LED Driver accepts a digital binary data stream which is processed by the driver circuitry to create a current waveform to modulate the LED device. The LED Driver contains circuitry to program the modulation current, pre-distort the input waveform to partially compensate for the LED turn-on/turn-off delay, and compensate for the negative optical output power tracking co-efficient. The LED Driver operates from a +5 V supply for PECL applications or a -5.2 V supply for traditional ECL systems. For further information on PECL, please consult “Designing with PECL Application Note”, AN1406/D available from a ON Semiconductor representative.

Circuit Blocks

Some of the key sub-circuits in the LED Driver are listed below:

- Input Line Receiver
- Pulse Stretcher
- Bias Control Circuitry
- Output Current Switch

The data input circuitry has been realized as a traditional differential ECL line receiver. It can accept either differential 100K or 10KH style ECL or PECL depending on the supply voltage used. In addition, a V_{BB} reference is provided for use in single ended applications. This reference is useful if the input signal must be AC coupled into the device.

The pulse stretcher provides two choices of duty cycle pre-distortion. It is controlled by the input STRETCH signal. When the pin is left open, no pre-distortion is applied to the input waveform. If the pin is strapped to the upper or lower rail, then the output waveform low pulse width will be increased. In a +5 V application, when the STRETCH pin is tied to +5 V, the nominal pulse width increase is 155 ps and when it is connected to 0 V, the nominal pulse width is increased by 310 ps.

The bias control circuitry regulates the voltage supplied at the RSET pin of the output current switch. In addition, it implements a positive tracking circuit which provides open loop temperature compensation for the LED’s negative tracking coefficient. An external resistor connected between the $RTCO_1$ and $RTCO_2$ is used to select the rate of voltage change at the RSET pin.

The output current switch is the final stage in modulating the LED. The emitter of the current source is pinned out so that an external resistor can be used to set the modulation current. This circuit is implemented using a fully differential gate where both collectors are brought out. As the LED is modulated on and off, the current switches from one collector to another. This architecture minimizes the switching noise inherent in some LED driver design topologies where the modulation current is actually turned on and off.

Design Considerations

Once the user has selected an LED, the driver circuitry should be optimized to match the characteristics of the LED. The three circuit blocks previously described allow the user to control the pulse width adjustment, LED drive current and temperature tracking rate. A very simple example may best illustrate the design process steps.

An LED has been selected which has the desired optical output power when modulated with a waveform of 65mA. In addition, the LED has an output power tracking coefficient of $-0.5\%/^{\circ}C$. Thus for every $1^{\circ}C$ rise in the case temperature of the LED, the output power will decrease by 0.5% of the nominal value. In addition, the LED forward voltage is 1.5 V.

First, the RSET resistor must be chosen to set the desired nominal modulation current based on the following equation:

$$RSET = V_{SET}/I_{MOD} \text{ (Equation 1)}$$

The voltage at VSET is a function of the RTCO tracking resistor, so the desired tracking rate (VTR) must also be chosen. To determine this, the equation must be normalized to correspond to how the LED has been specified.

$$\text{Temp Co} = V_{TR}/V_{SET} \text{ (Equation 2)}$$

The data sheet has three temperature tracking rates for different values of the RTCO resistor. By using the VSET values at 25°C and substituting those numbers into Equation 2, normalized tracking rates can be calculated.

Table 5. Normalized Tracking at 25°C

RTCO	Tracking %/°C
Short	+0.20
1 KΩ	+0.52
2 KΩ	+0.89

To match the LED chosen, a 1 kΩ resistor can be used. Now that this is known, the value of the voltage at the VSET can be substituted into Equation 1 to determine the value of RSET resistor which, for this example is 10 Ω.

The Stretch circuit can be used to compensate for the turn-on/turn-off delay of the LED. The circuit has been designed for ease of use so the pin is designed to be strapped to one of the two power plane levels to select the pre-distortion value. If no pre-distortion is desired, the pin can be left open. In this +5 V example, the maximum amount of pre-distortion is desired, so the STRETCH pin is connected to ground.

In addition a resistor must be placed between I_{OUT} and V_{CC}. In selecting this resistor, just as in the case of the RSET, the resistor type should be chosen to dissipate the worst case power and derated for the worst case temperature. As a rule of thumb, the voltage drop across the resistor should match the forward voltage across the diode. The voltage can be larger to minimize the power dissipated on chip when the LED is not 'ON'. Although, the voltage drop across this resistor should not be greater than 2 V. For this example:

$$R @ \overline{I_{OUT}} = VF/I_{MOD}$$

$$I_{MOD(max)} = \frac{V_{SET@85^\circ C}}{RSET} = \frac{855mV}{10\Omega} = 86mA$$

$$R @ \overline{I_{OUT}} = 1.5V/86mA = 17\Omega$$

Because of the positive tracking circuitry in the LED driver, the modulation current will increase over temperature. It is important to now go back and re-calculate the numbers under the worst case environmental conditions to ensure that operating conditions have not been exceeded.

Thermal Management

LED devices tend to require large amounts of current for most efficient operation. This requirement is then translated into the design of the LED Driver. When large modulation currents are required, power dissipation becomes a critical issue and the user must be concerned about the junction temperature of the device. The following equation can be used to estimate the junction temperature of a device in a given environment:

$$T_J = T_A + P_D * \theta_{JA} \text{ (Equation 3)}$$

- T_J Junction Temperature
- T_A Ambient Temperature
- P_D Power Dissipation
- θ_{JA} Average Thermal Resistance (Junction-Ambient)

A specially designed thermally enhanced leadframe has been used to house the LED Driver. Below is a graph of the average θ_{JA} plotted against air flow.

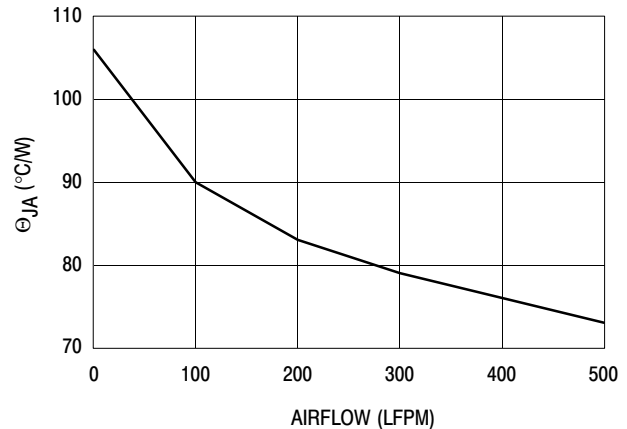

Figure 4. Typical θ_{JA} versus Airflow

The power dissipation of the device has two components; the quiescent power drain related to the pre-drive circuitry, and the power dissipated in the current switch when driving the LED.

$$P_d = P_{static} + P_{switching} \text{ (Equation 4)}$$

The power dissipated in the current switch is a function of the I_{MOD} current, the LED forward voltage, and the value of RSET. For example in a +5 V application, the following equations can be used:

$$P_{static} = V_{CC} * I_{CC} \text{ (Equation 5)}$$

$$P_{switching} = (V_{CC}-V_F-V_{SET}) * I_{MOD} \text{ (Equation 6)}$$

MC10SX1130

Now to calculate the dissipated power on the chip for a nominal application.

$$\begin{aligned} V_{CC} &= 5 \text{ V} \\ V_F &= 1.5 \text{ V} \\ V_{SET} &= 0.7 \text{ V} \\ I_{MOD} &= 60 \text{ mA} \\ I_{CC} &= 18 \text{ mA} \end{aligned}$$

so:

$$\begin{aligned} P_d &= 5 * 18 + (5 - 1.5 - 0.7) * 60 \\ P_d &= 258 \text{ mW} \end{aligned}$$

This number can be entered into Equation 3 along with the environmental information to calculate the nominal operating junction temperature.

Because of the open loop feedback control in the bias control circuitry, the revised I_{MOD} value must be determined given the tracking rate chosen so that the power dissipation can be re-calculated. For assessing product reliability, worst case values should be entered to calculate the maximum junction temperature.

Reliability of Plastic Packages

Although today's plastic packages are as reliable as ceramic packages under most environmental conditions, as the junction temperature increases a failure mode unique to plastic packages becomes a significant factor in the long term reliability of the device.

Modern plastic package assembly utilizes gold wire bonded to aluminum bonding pads throughout the electronics industry. As the temperature of the silicon (junction temperature) increases, an intermetallic compound forms between the gold and aluminum interface. This intermetallic formation results in a significant increase in the impedance of the wire bond and can lead to

performance failure of the affected pin. With this relationship between intermetallic formation and junction temperature established, it is incumbent on the designer to ensure that the junction temperature for which a device will operate is consistent with the long term reliability goals of the system.

Reliability studies were performed at elevated ambient temperatures (125°C) from which an Arrhenius Equation, relating junction temperature to bond failure, was established. The application of this equation yields the table of Table 6. This table relates the junction temperature of a device in a plastic package to the continuous operating time before 0.1% bond failure (1 failure per 1000 bonds)

The MC10SX1130 device is designed with chip power levels that permit acceptable reliability levels, in most systems, under the conventional 500 lfpm (2.5 m/s) airflow.

$$T = 6.376 \times 10^{-9} e^{\left[\frac{11554.267}{273.15 + T_J} \right]}$$

Where:

T = Time to 0.1% bond failure

Table 6. T_J vs Time to 0.1% Bond Failure

Junction Temp. (°C)	Time (Hrs.)	Time (yrs.)
80	1,032,200	117.8
90	419,300	47.9
100	178,700	20.4
110	79,600	9.1
120	37,000	4.2
130	17,800	2.0
140	8,900	1.0

ORDERING INFORMATION

Device	Package	Shipping [†]
MC10SX1130D	SOIC-16	48 Units / Rail
MC10SX1130DG	SOIC-16 (Pb-Free)	48 Units / Rail
MC10SX1130DR2	SOIC-16	2500 / Tape & Reel
MC10SX1130DR2G	SOIC-16 (Pb-Free)	2500 / Tape & Reel

[†]For information on tape and reel specifications, including part orientation and tape sizes, please refer to our Tape and Reel Packaging Specifications Brochure, BRD8011/D.

MC10SX1130

PACKAGE DIMENSIONS

SOIC-16
D SUFFIX
CASE 751B-05
ISSUE J

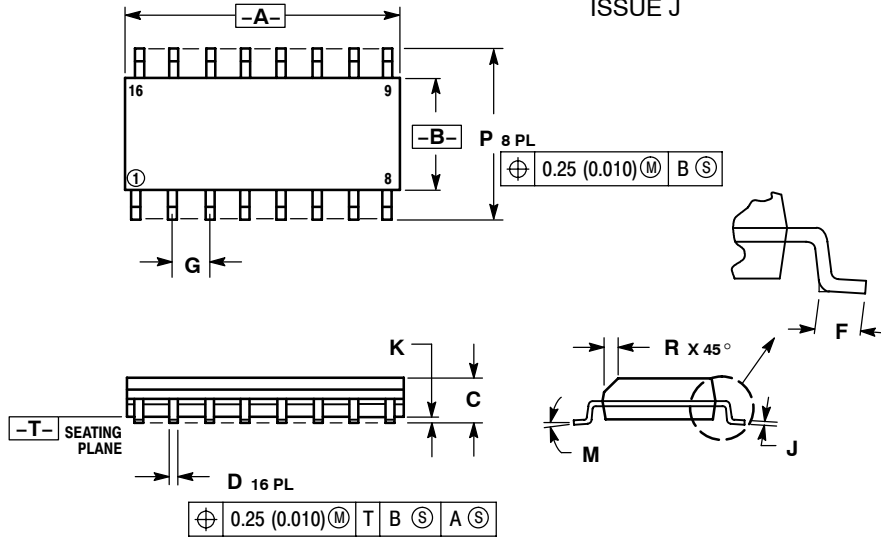

NOTES:

1. DIMENSIONING AND TOLERANCING PER ANSI Y14.5M, 1982.
2. CONTROLLING DIMENSION: MILLIMETER.
3. DIMENSIONS A AND B DO NOT INCLUDE MOLD PROTRUSION.
4. MAXIMUM MOLD PROTRUSION 0.15 (0.006) PER SIDE.
5. DIMENSION D DOES NOT INCLUDE DAMBAR PROTRUSION. ALLOWABLE DAMBAR PROTRUSION SHALL BE 0.127 (0.005) TOTAL IN EXCESS OF THE D DIMENSION AT MAXIMUM MATERIAL CONDITION.

DIM	MILLIMETERS		INCHES	
	MIN	MAX	MIN	MAX
A	9.80	10.00	0.386	0.393
B	3.80	4.00	0.150	0.157
C	1.35	1.75	0.054	0.068
D	0.35	0.49	0.014	0.019
F	0.40	1.25	0.016	0.049
G	1.27 BSC		0.050 BSC	
J	0.19	0.25	0.008	0.009
K	0.10	0.25	0.004	0.009
M	0°	7°	0°	7°
P	5.80	6.20	0.229	0.244
R	0.25	0.50	0.010	0.019

MOSAIC III is a trademark of Motorola, Inc.

ON Semiconductor and are registered trademarks of Semiconductor Components Industries, LLC (SCILLC). SCILLC reserves the right to make changes without further notice to any products herein. SCILLC makes no warranty, representation or guarantee regarding the suitability of its products for any particular purpose, nor does SCILLC assume any liability arising out of the application or use of any product or circuit, and specifically disclaims any and all liability, including without limitation special, consequential or incidental damages. "Typical" parameters which may be provided in SCILLC data sheets and/or specifications can and do vary in different applications and actual performance may vary over time. All operating parameters, including "Typicals" must be validated for each customer application by customer's technical experts. SCILLC does not convey any license under its patent rights nor the rights of others. SCILLC products are not designed, intended, or authorized for use as components in systems intended for surgical implant into the body, or other applications intended to support or sustain life, or for any other application in which the failure of the SCILLC product could create a situation where personal injury or death may occur. Should Buyer purchase or use SCILLC products for any such unintended or unauthorized application, Buyer shall indemnify and hold SCILLC and its officers, employees, subsidiaries, affiliates, and distributors harmless against all claims, costs, damages, and expenses, and reasonable attorney fees arising out of, directly or indirectly, any claim of personal injury or death associated with such unintended or unauthorized use, even if such claim alleges that SCILLC was negligent regarding the design or manufacture of the part. SCILLC is an Equal Opportunity/Affirmative Action Employer. This literature is subject to all applicable copyright laws and is not for resale in any manner.

PUBLICATION ORDERING INFORMATION

LITERATURE FULFILLMENT:
Literature Distribution Center for ON Semiconductor
P.O. Box 61312, Phoenix, Arizona 85082-1312 USA
Phone: 480-829-7710 or 800-344-3860 Toll Free USA/Canada
Fax: 480-829-7709 or 800-344-3867 Toll Free USA/Canada
Email: orderlit@onsemi.com

N. American Technical Support: 800-282-9855 Toll Free
USA/Canada

Japan: ON Semiconductor, Japan Customer Focus Center
2-9-1 Kamimeguro, Meguro-ku, Tokyo, Japan 153-0051
Phone: 81-3-5773-3850

ON Semiconductor Website: <http://onsemi.com>

Order Literature: <http://www.onsemi.com/litorder>

For additional information, please contact your local Sales Representative.