

UNIT:mm

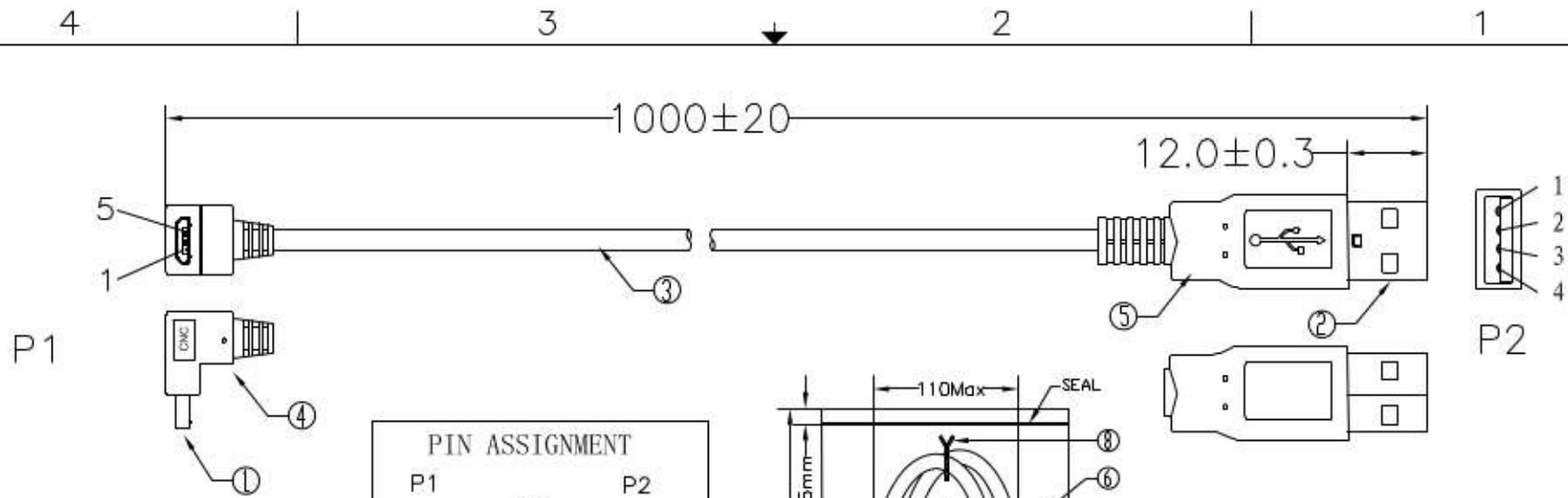

PIN ASSIGNMENT			
P1		P2	
1	RED	1	
2	WHITE	2	
3	GREEN	3	
5	BLACK	4	
SHELL	DRAIN+BRAID	SHELL	

Electrical test:
 1.100% short,open,miswtr test
 2.Conduct resistance:2 Ohm(max)
 3.Insulation resistance:10Mohm(min)
 4.dielectric test:DC 300V

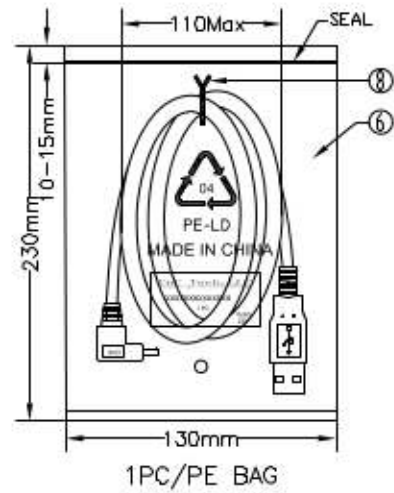

⑧	TIE	1	BLACK L=60mm
⑦	PE BAG	1/10	CLEAR SIZE: 280*330*0.05mm PRINT BLACK"MADE IN CHINA"*+10PCS"及印生产周期,有透气孔.
⑥	PE BAG	1	CLEAR SIZE: 130*230*0.05mm PRINT BLACK"MADE IN CHINA"*+1PC"及印生产周期,有透气孔.
⑤	OUT JACKET	6g	BLACK PVC-40P (MOULD NO:WM-40)
④	IN JACKET	2g	CAEAR PE (MOULD NO:NM-140)
	OUT JACKET	6g	BLACK PVC-40P (MOULD NO:WM-272)
③	CABLE	1	USB2.0 UL2725 [28AWG(7/0.12TC+AL)*1P+28AWG(7/0.12TC)*2C]+AEB(48B ALMG) JACKET:BLACK OD:3.5mm L=1000±10mm
②	CONN	1set	USB A MALE SHELL:NICKEL PIN:G/F CRIMP TYPE INSULATOR COLOR:WHITE
①	CONN	1	MICRO USB 5P B/M SOLDER TYPE SHELL:NICKEL PIN:G/F INSULATOR COLOR:BLACK
NO.	NAME	Q'TY	SPECIFICATION

CnC Tech, LLC
 Industrial Cable and Connector Technology

DRAWN	ANDY	DRAWING NO	VG/LJQ-094-087-B
CHECKED		CUSTOMER	C N C
APPROVAL		ITEM NO.	102-1392-BL-00100
DECIDED		DATE	2014-06-16
VERSIONS/EDITEDN	A/O	PROJECTION	