

## X-LRM-E Series Datasheet



- 25, 50, 100, 150, 200 mm travel
- Up to 8  $\mu\text{m}$  accuracy and 50 nm resolution
- 50 kg load capacity
- Hardened steel construction and integrated recirculating ball bearing guide provide exceptional stiffness and thermal stability
- Motor encoder position feedback with slip/stall detection and automatic recovery
- Built-in controller, daisy-chains with other Zaber products

### X-LRM-E Series Overview

Zaber's X-LRM-E Series products are motorized linear stages with integrated controllers. The X-LRM-E's hardened steel construction and recirculating ball bearing guide provide exceptional rigidity and thermal stability. High stiffness makes the X-LRM-E ideal for multi-axis configurations or applications where excellent stability under cantilever loads is required.

The X-LRM-E stages are stand-alone units requiring only a standard 24-48 V power supply. An indexed knob at the end of the unit permits manual control - press and hold to switch between velocity mode and position mode, turn to move the stage, and press to stop.

The stages connect to the USB 2.0 or RS-232 port of any computer and can be chained with several units per chain. They can be chained with any other Zaber products. Convenient locking, 4-pin, M8

connectors on the unit allow for easy and secure connection between products. The chain also shares power, so multiple X-Series products can use a single power supply.

For more information visit: <https://www.zaber.com/products/linear-stages/X-LRM-E>

### X-LRM-E Series Part Numbering

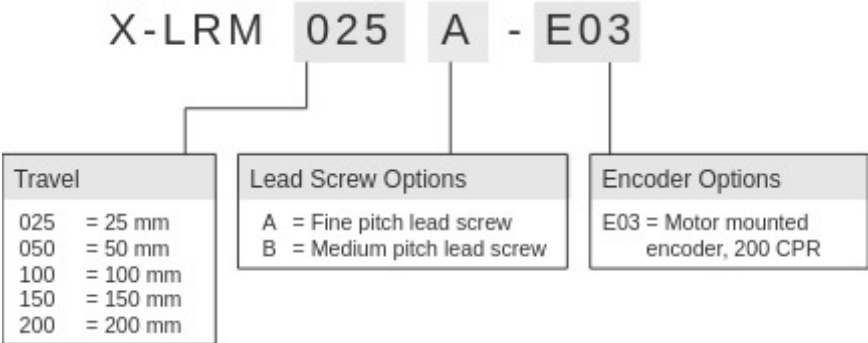

# X-LRM-E Series Drawings

## ZABER

X-LRM-E Motorized Linear Stage  
dimensions in mm

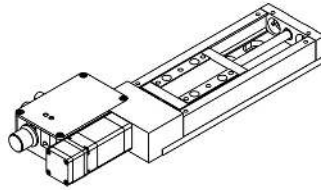

| Model Number* | Travel | A     | B     |
|---------------|--------|-------|-------|
| X-LRM025-E    | 25.0   | 190.9 | 93.8  |
| X-LRM050-E    | 50.0   | 215.9 | 118.8 |
| X-LRM100-E    | 100.0  | 265.9 | 168.8 |
| X-LRM150-E    | 150.0  | 315.9 | 218.8 |
| X-LRM200-E    | 200.0  | 365.9 | 268.8 |

\*See product page for complete list of available models at [www.zaber.com](http://www.zaber.com)

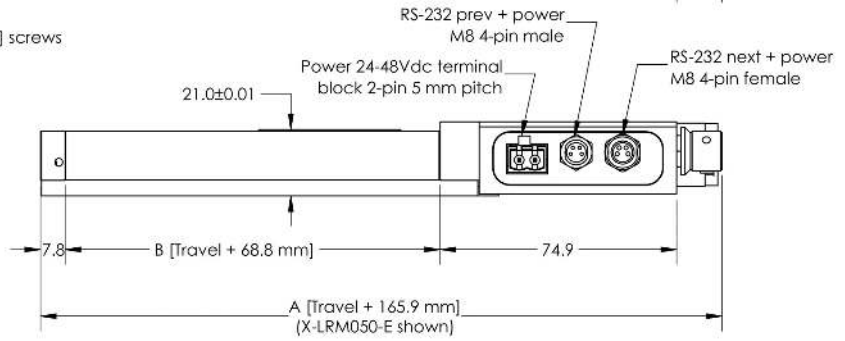
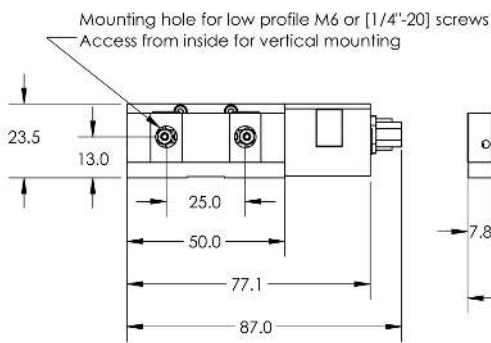
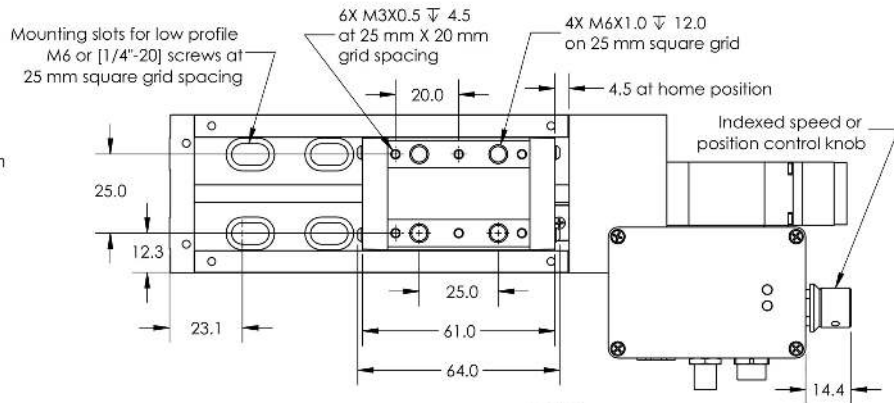

DWG - 21 NOTE

## X-LRM-E Series Specifications

| Specification                       | Value                               | Alternate Unit         |
|-------------------------------------|-------------------------------------|------------------------|
| Microstep Size (Default Resolution) | 0.1905 $\mu\text{m}$                |                        |
| Built-in Controller                 | Yes                                 |                        |
| Travel Range                        | 200.0 mm                            | 7.874"                 |
| Accuracy (unidirectional)           | 60 $\mu\text{m}$                    | 0.002362"              |
| Repeatability                       | < 4 $\mu\text{m}$                   | < 0.000157"            |
| Backlash                            | < 12 $\mu\text{m}$                  | < 0.000472"            |
| Maximum Speed                       | 100 mm/s                            | 3.937"/s               |
| Minimum Speed                       | 0.000116 mm/s                       | 0.000005"/s            |
| Speed Resolution                    | 0.000116 mm/s                       | 0.000005"/s            |
| Encoder Resolution                  | 200 CPR                             | 800 states/rev         |
| Encoder Type                        | Rotary quadrature encoder           |                        |
| Peak Thrust                         | 25 N                                | 5.6 lb                 |
| Maximum Continuous Thrust           | 25 N                                | 5.6 lb                 |
| Communication Interface             | RS-232, USB 2.0                     |                        |
| Communication Protocol              | Zaber ASCII (Default), Zaber Binary |                        |
| Maximum Centered Load               | 500 N                               | 112.1 lb               |
| Maximum Cantilever Load             | 1500 N-cm                           | 2124.2 oz-in           |
| Guide Type                          | Recirculating ball bearing          |                        |
| Vertical Runout                     | < 8 $\mu\text{m}$                   | < 0.000315"            |
| Horizontal Runout                   | < 12 $\mu\text{m}$                  | < 0.000472"            |
| Pitch                               | 0.02°                               | 0.349 mrad             |
| Roll                                | 0.02°                               | 0.349 mrad             |
| Yaw                                 | 0.02°                               | 0.349 mrad             |
| Stiffness in Pitch                  | 750 N-m/°                           | 23 $\mu\text{rad/N-m}$ |
| Stiffness in Roll                   | 550 N-m/°                           | 32 $\mu\text{rad/N-m}$ |
| Stiffness in Yaw                    | 400 N-m/°                           | 44 $\mu\text{rad/N-m}$ |
| Maximum Current Draw                | 350 mA                              |                        |
| Power Supply                        | 24-48 VDC                           |                        |
| Power Plug                          | 2-pin Screw Terminal                |                        |
| Linear Motion Per Motor Rev         | 2.4384 mm                           | 0.096"                 |

| Specification               | Value                    | Alternate Unit |
|-----------------------------|--------------------------|----------------|
| Motor Steps Per Rev         | 200                      |                |
| Motor Type                  | Stepper (2 phase)        |                |
| Motor Rated Current         | 600 mA/phase             |                |
| Inductance                  | 3.5 mH/phase             |                |
| Default Resolution          | 1/64 of a step           |                |
| Data Cable Connection       | Locking 4-pin M8         |                |
| Mechanical Drive System     | Precision lead screw     |                |
| Limit or Home Sensing       | Magnetic hall sensor     |                |
| Manual Control              | Yes                      |                |
| Axes of Motion              | 1                        |                |
| Mounting Interface          | M3 and M6 threaded holes |                |
| Operating Temperature Range | 0 to 50 °C               |                |
| Vacuum Compatible           | No                       |                |
| RoHS Compliant              | Yes                      |                |
| Stage Parallelism           | < 10 µm                  | < 0.000394"    |
| CE Compliant                | Yes                      |                |
| Weight                      | 1.31 kg                  | 2.888 lb       |

X-LRM-E Series Charts

Thrust Speed Performance

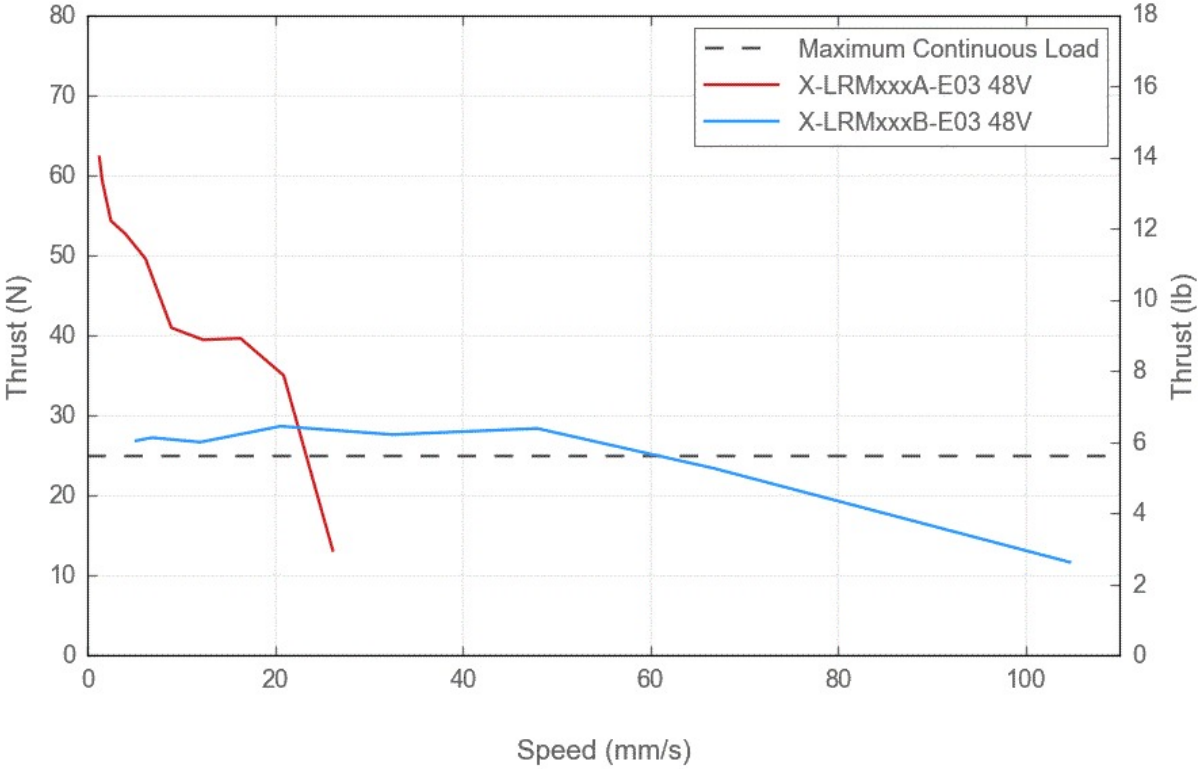

## Thrust Speed Performance

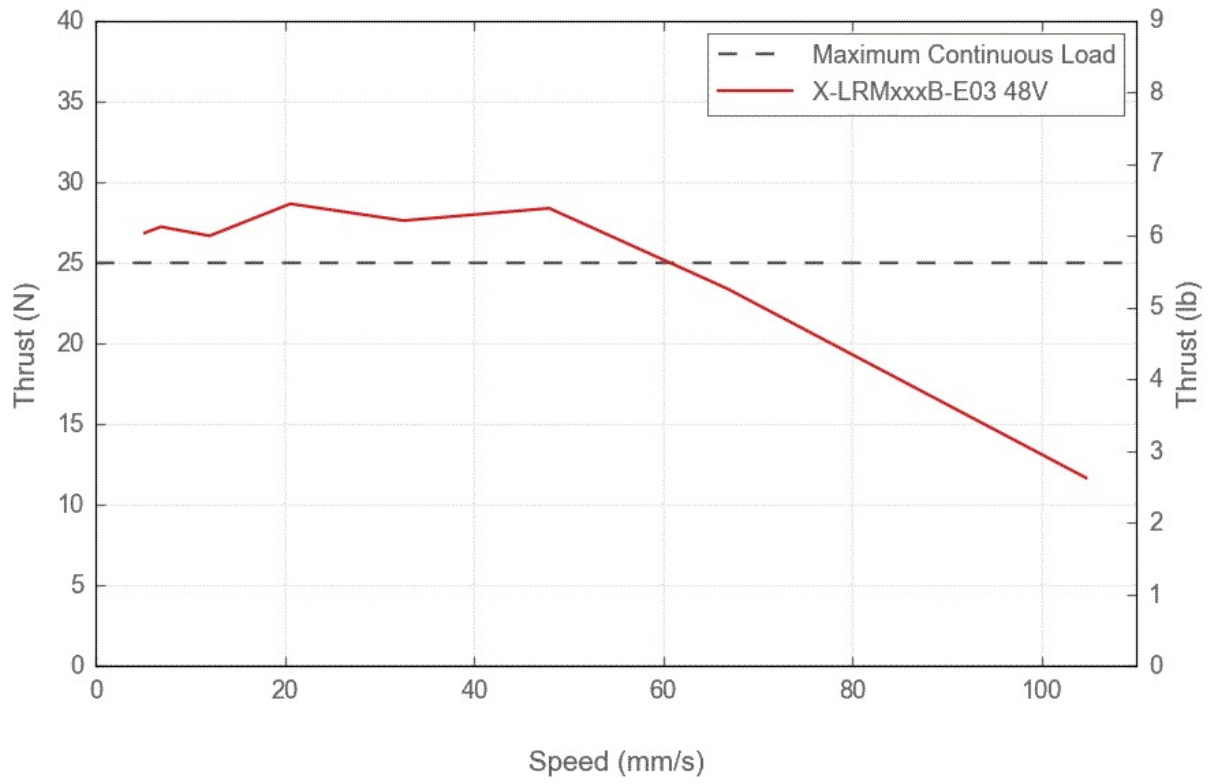

## Thrust Speed Performance

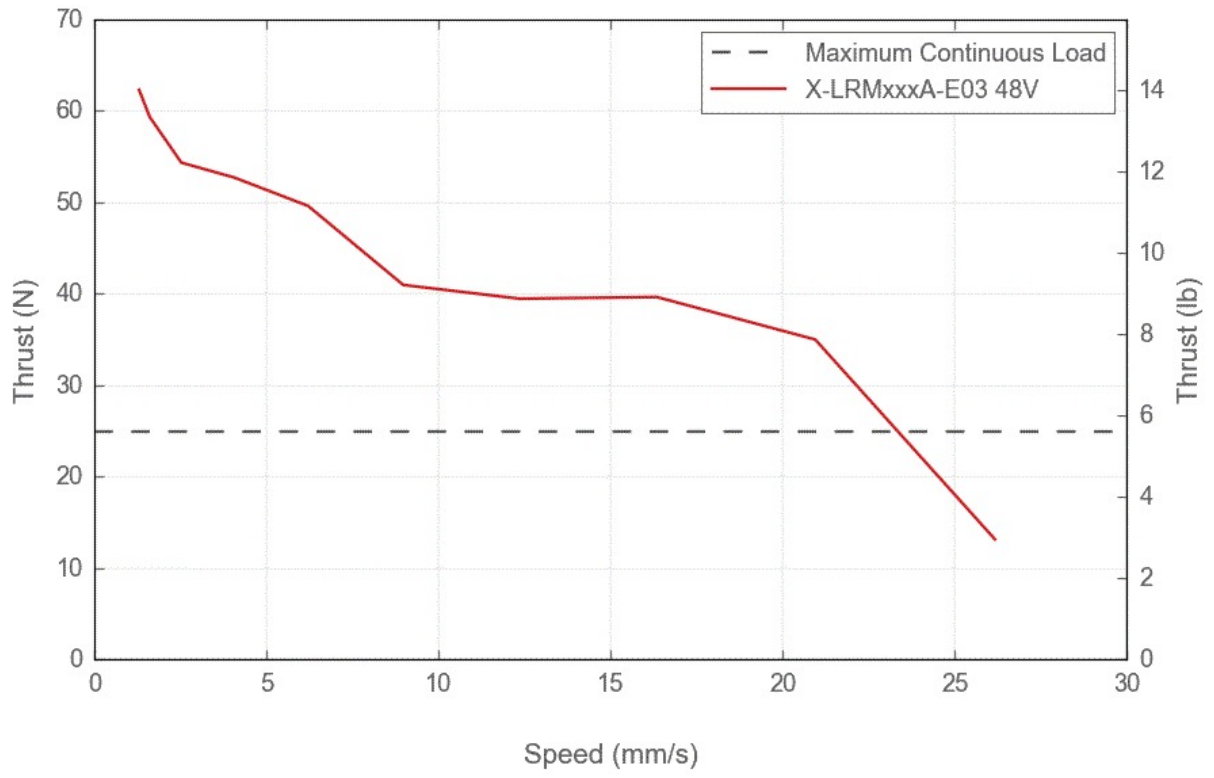



## Typical Microstepping Accuracy

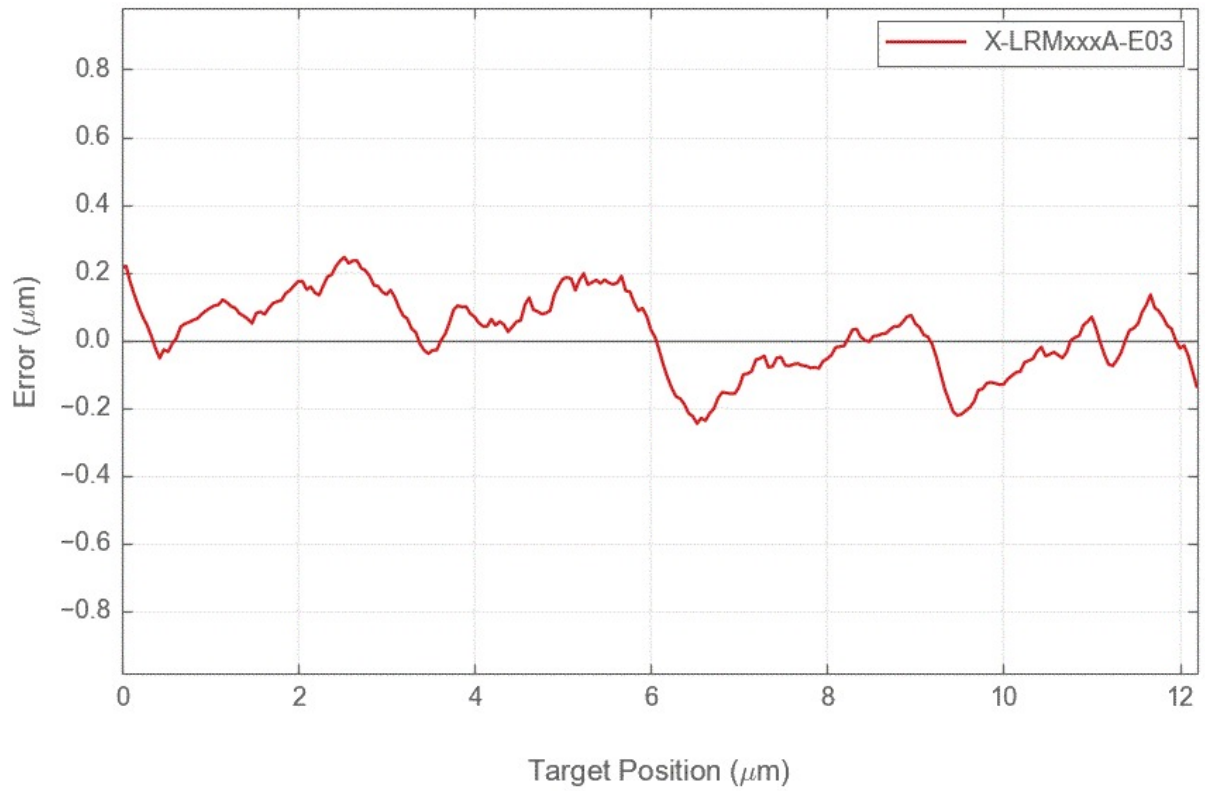

## Typical Microstepping Accuracy

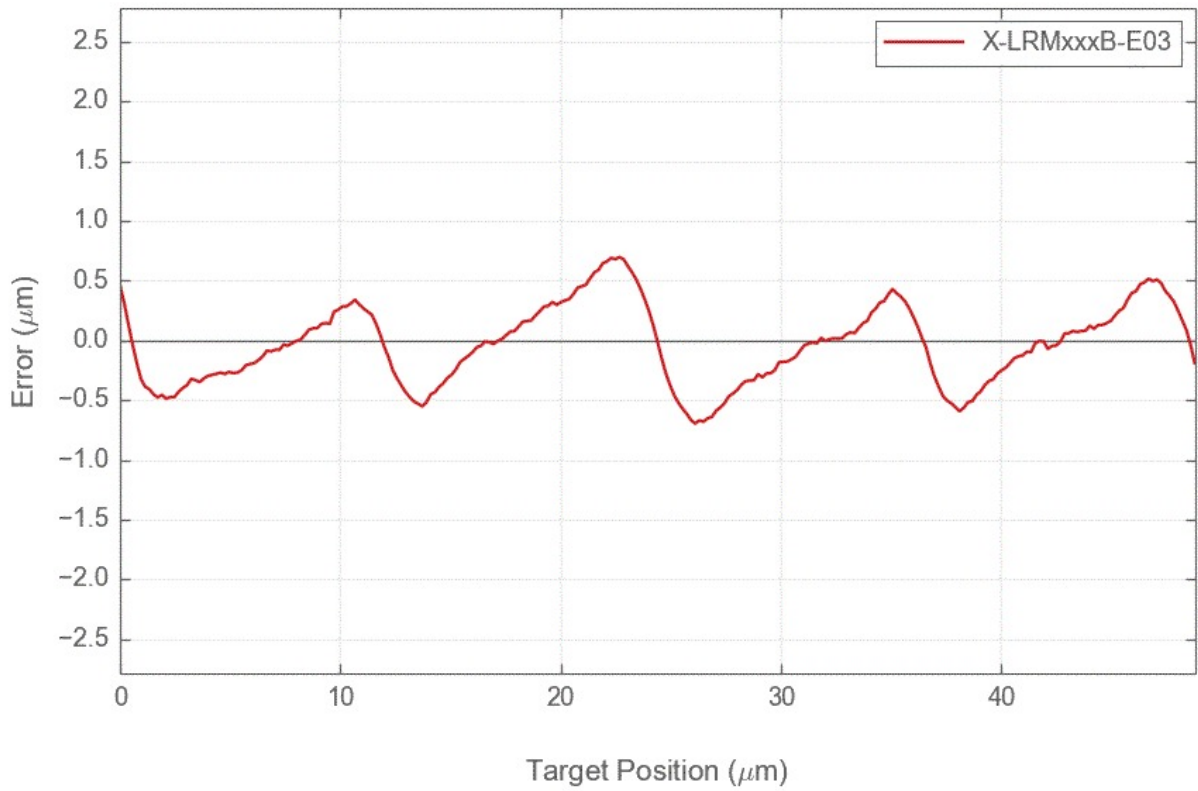

## LRM Linear Bearing Lifetime

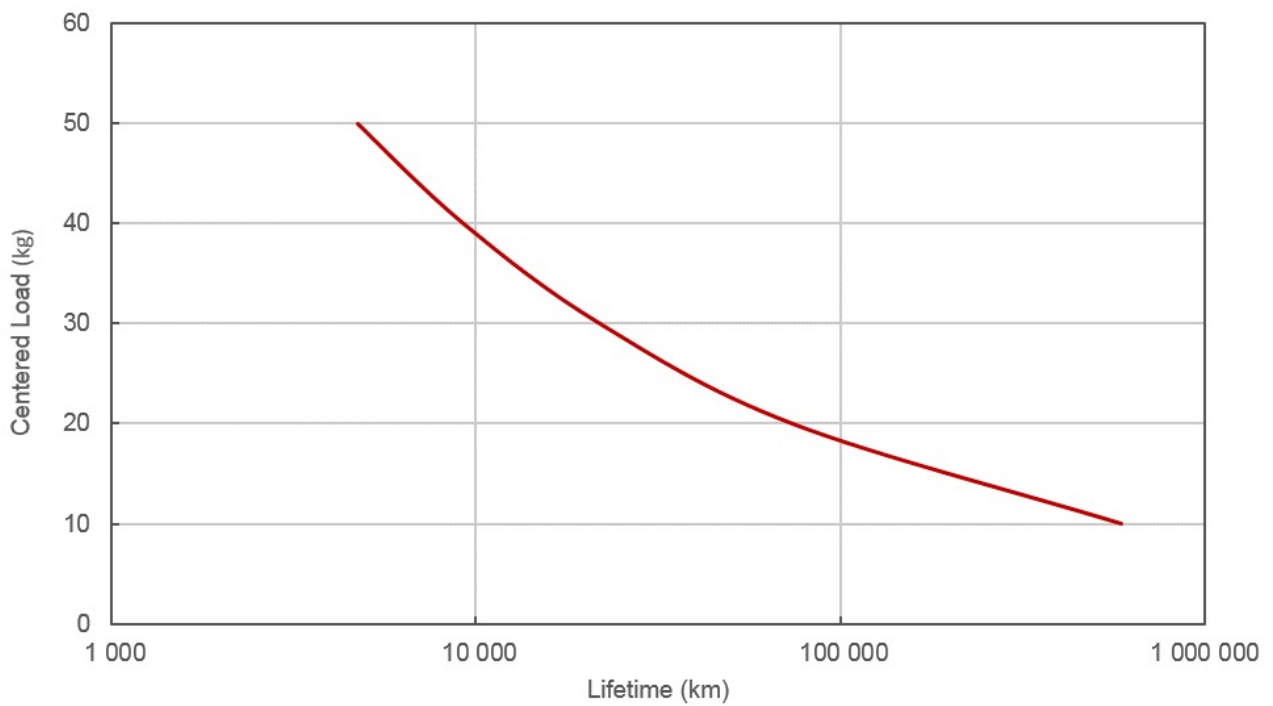

## Contact

Email: [contact@zaber.com](mailto:contact@zaber.com)

Phone (toll free Canada/USA): 1-888-276-8033

Phone (direct): 1-604-569-3780

Fax: 1-604-648-8033

Zaber Technologies Inc.

#2 - 605 West Kent Ave. N.

Vancouver, British Columbia

Canada, V6P 6T7

<https://www.zaber.com>