

TMS470R1VF689, TMS470R1VF688 16/32-BIT RISC FLASH MICROCONTROLLERS

SPNS0011 – FEBRUARY 2002 – REVISED AUGUST 2005

- High-Performance Static CMOS Technology
- TMS470R1x 16/32-Bit RISC Core (ARM7TDMI™)
 - 24-MHz System Clock (48-MHz Pipeline Mode)
 - Independent 16/32-Bit Instruction Set
 - Open Architecture With Third-Party Support
 - Built-In Debug Module
- Integrated Memory (VF689 only)
 - 384K-Byte Program Flash
 - Three Banks With 18 Contiguous Sectors
 - 16K-Byte Static RAM (SRAM)
- Integrated Memory (VF688 only)
 - 256K-Byte Program Flash
 - Two Banks With 14 Contiguous Sectors
 - 12K-Byte Static RAM (SRAM)
- Operating Features
 - Core Supply Voltage (V_{CC}): 1.71 V - 2.05 V
 - I/O Supply Voltage (V_{CCIO}): 3.0 V - 3.6 V
 - Low-Power Modes: STANDBY and HALT
 - Industrial/Automotive Temperature Ranges
- 470+ System Module
 - 32-Bit Address Space Decoding
 - Bus Supervision for Memory and Peripherals
 - Analog Watchdog (AWD) Timer
 - Enhanced Real-Time Interrupt (RTI)
 - System Integrity and Failure Detection
- Direct Memory Access (DMA) Controller
 - 32 Control Packets and 16 Channels
- Zero-Pin Phase-Locked Loop (ZPLL)-Based Clock Module With Prescaler
 - Multiply-by-4 or -8 Internal ZPLL Option
 - ZPLL Bypass Mode
- Ten Communication Interfaces:
 - Two Serial Peripheral Interfaces (SPIs)
 - 255 Programmable Baud Rates
 - Two Serial Communication Interfaces (SCIs)
 - 2^{24} Selectable Baud Rates
 - Asynchronous/Isosynchronous Modes
 - Two Standard CAN Controllers (SCC)
 - 16-Mailbox Capacity
 - Fully Compliant With CAN Protocol, Version 2.0B
 - Class II Serial Interface (C2SIb)
 - Normal 10.4 Kbps and 4X Mode 41.6 Kbps
- Three Inter-Integrated Circuit (I2C) Modules
 - Multi-Master and Slave Interfaces
 - Up to 400 Kbps (Fast Mode)
 - 7- and 10-Bit Address Capability
- High-End Timer (HET)
 - 12 Programmable I/O Channels:
 - 12 High-Resolution Pins
 - High-Resolution Share Feature (XOR)
 - High-End Timer RAM
 - 64-Instruction Capacity
- External Clock Prescale (ECP) Module
 - Programmable Low-Frequency External Clock (CLK)
- 12-Channel 10-Bit Multi-Buffered ADC (MibADC)
 - 32-Word FIFO Buffer
 - Single- or Continuous-Conversion Modes
 - 1.55 μ s Minimum Sample and Conversion Time
 - Calibration Mode and Self-Test Features
- Flexible Interrupt Handling
- Expansion Bus Module (EBM) (PGE only)
 - Supports 8- and 16-Bit Expansion Bus Memory Interface Mappings
 - 40 I/O Expansion Bus Pins
- 55 Dedicated General-Purpose I/O (GIO) Pins and 39 Additional Peripheral I/Os (PGE Suffix))
- 14 Dedicated GIO Pins and 39 Additional Peripheral I/Os (PZ Suffix)
- Eight External Interrupts
- Compatible ROM Device (Planned)
- On-Chip Scan-Base Emulation Logic, IEEE Standard 1149.1⁽¹⁾ (JTAG) Test-Access Port
- 144-Pin Plastic Low-Profile Quad Flatpack (PGE Suffix)
- 100-Pin Plastic Low-Profile Quad Flatpack (PZ Suffix)
- Development System Support Tools Available
 - Code Composer Studio™ Integrated Development Environment (IDE)
 - HET Assembler and Simulator
 - Real-Time In-Circuit Emulation
 - Flash Programming



Please be aware that an important notice concerning availability, standard warranty, and use in critical applications of Texas Instruments semiconductor products and disclaimers thereto appears at the end of this data sheet.

Code Composer Studio is a trademark of Texas Instruments.

ARM7TDMI is a trademark of Advanced RISC Machines Limited (ARM).

All trademarks are the property of their respective owners.

1 The test-access port is compatible with the IEEE Standard 1149.1-1990, *IEEE Standard Test-Access Port and Boundary Scan Architecture* specification. Boundary scan is not supported on this device.

PRODUCTION DATA information is current as of publication date. Products conform to specifications per the Texas Instruments standard warranty. Production processing does not necessarily include testing of all parameters.



Copyright © 2005, Texas Instruments Incorporated

TMS470R1VF689, TMS470R1VF688

16/32-BIT RISC FLASH MICROCONTROLLERS

SPNS001I – FEBRUARY 2002 – REVISED AUGUST 2005

TMS470R1VF68x 100-PIN PZ PACKAGE (TOP VIEW)

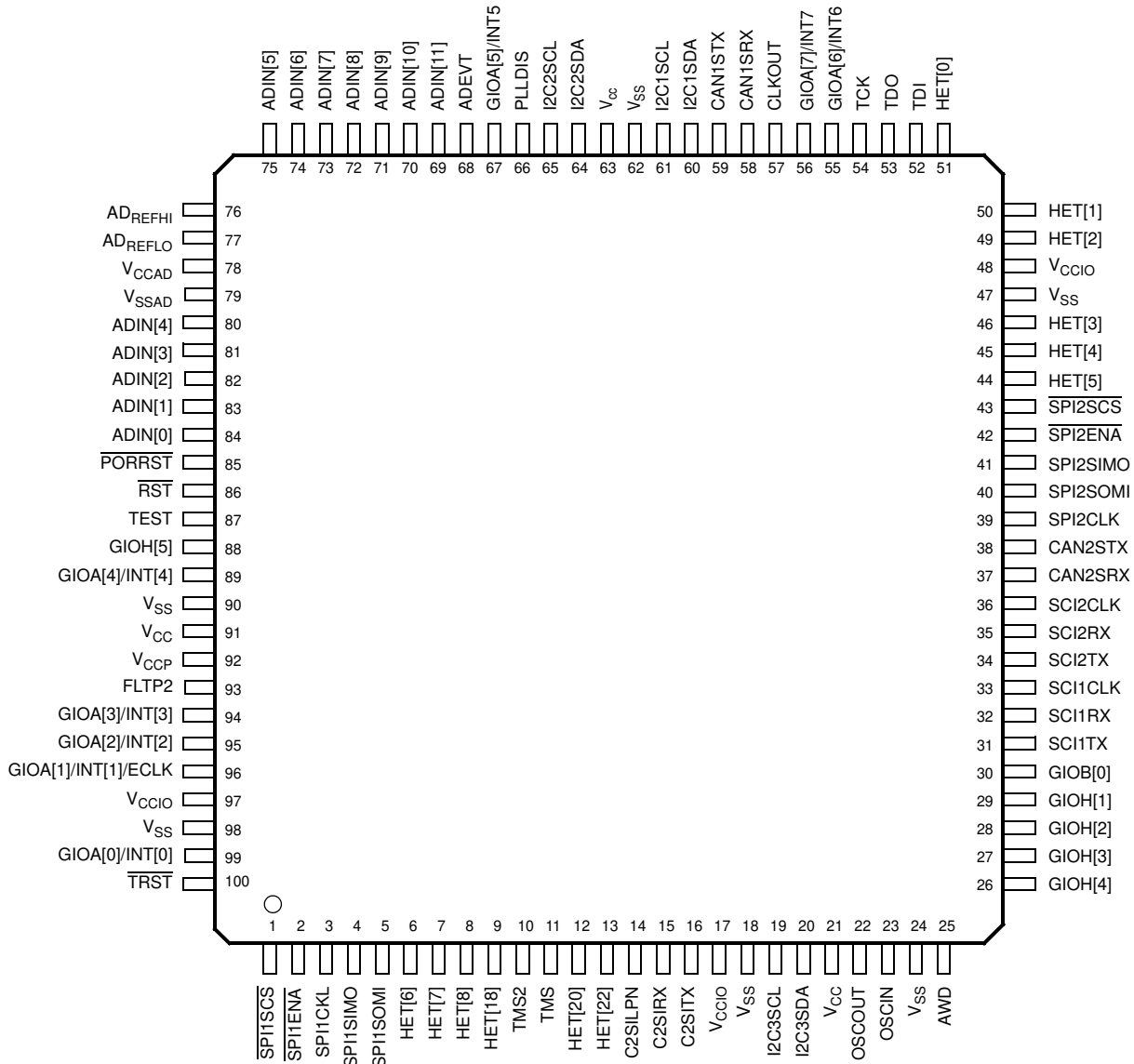

TMS470R1VF689, TMS470R1VF688

16/32-BIT RISC FLASH MICROCONTROLLERS

SPNS0011 – FEBRUARY 2002 – REVISED AUGUST 2005

TMS470R1VF68x 144-PIN PGE PACKAGE (TOP VIEW) (without Expansion Bus)

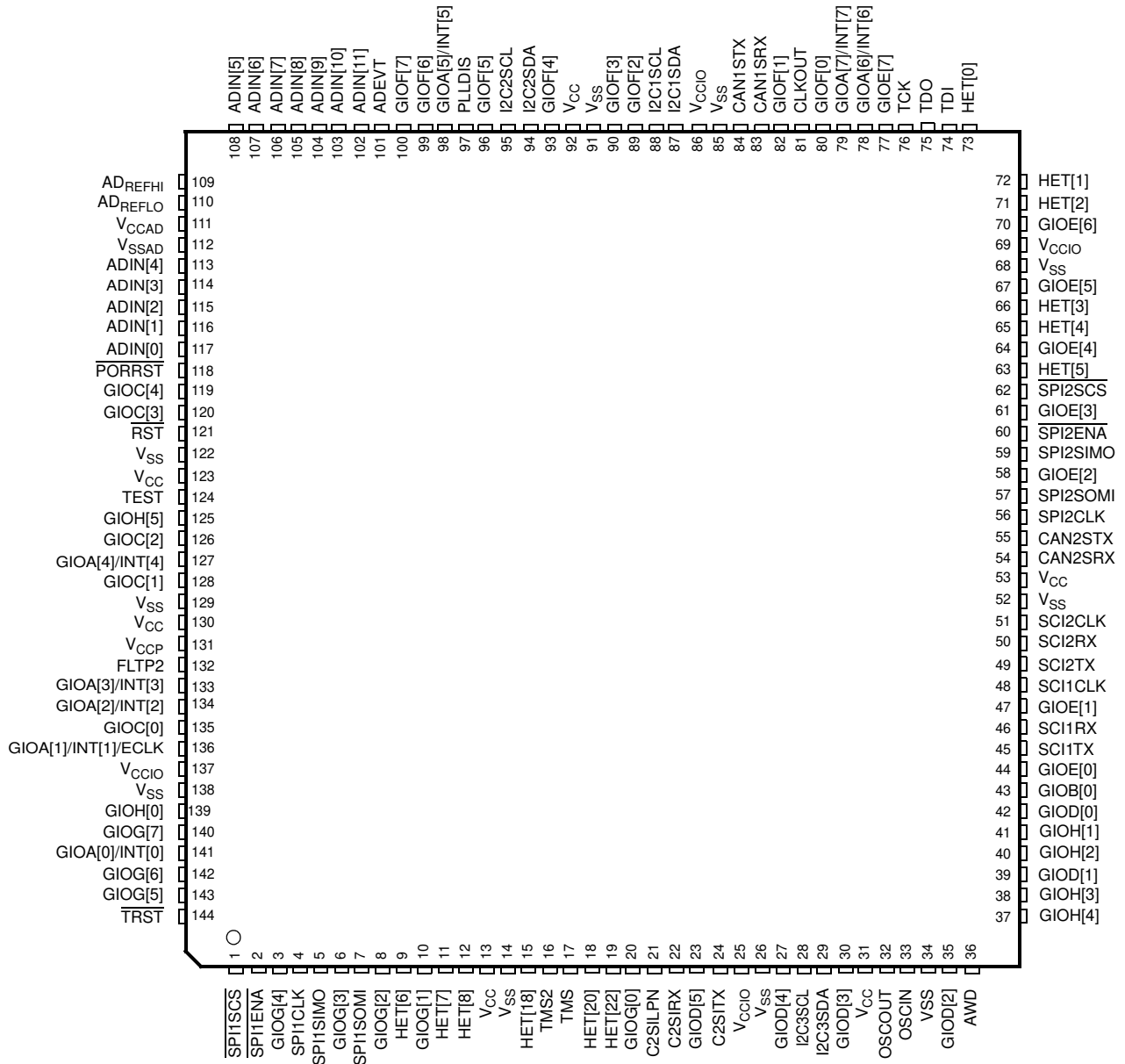

TMS470R1VF689, TMS470R1VF688

16/32-BIT RISC FLASH MICROCONTROLLERS

SPNS001I – FEBRUARY 2002 – REVISED AUGUST 2005

TMS470R1VF68x 144-PIN PGE PACKAGE (TOP VIEW) (with Expansion Bus)

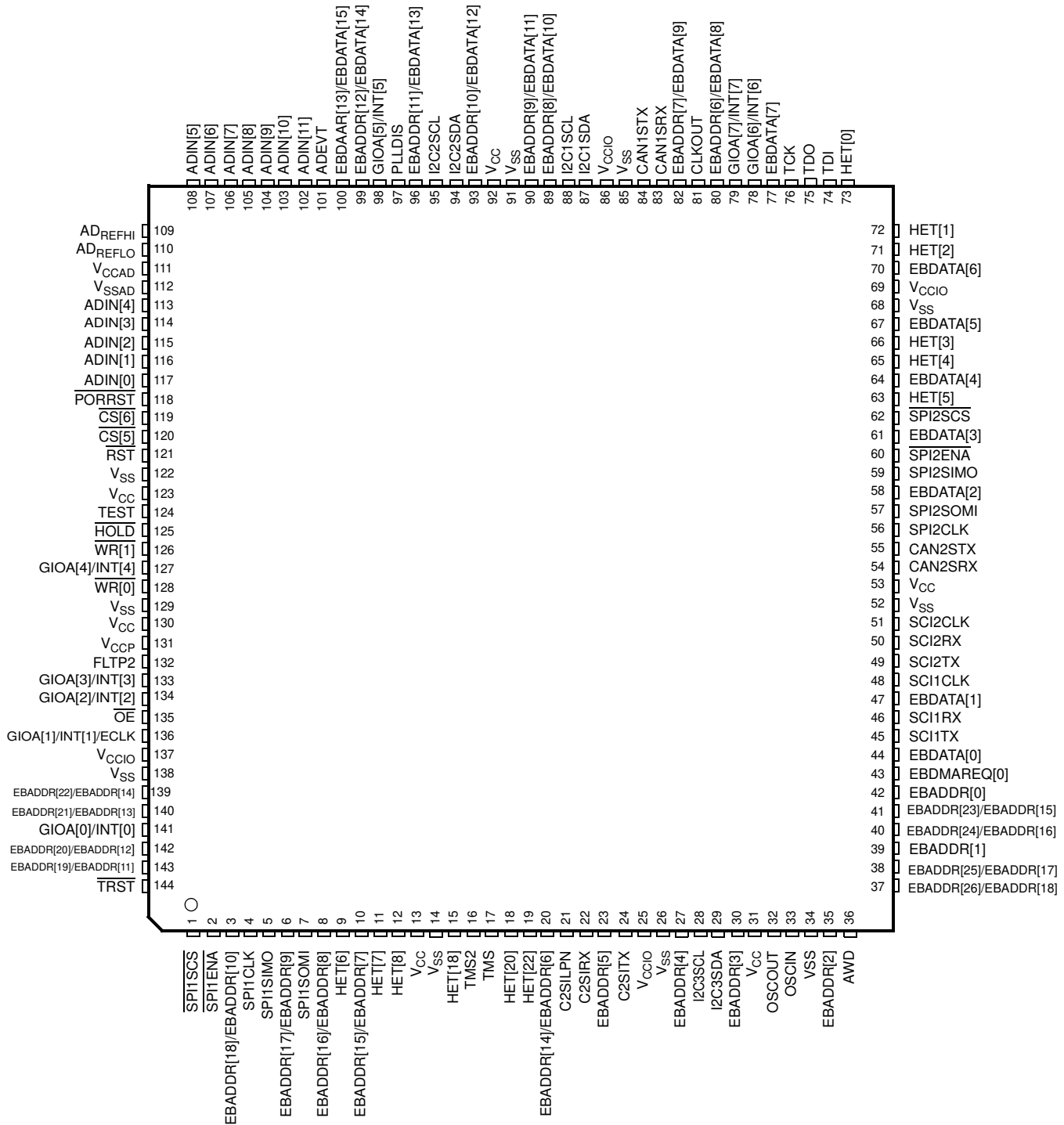

description

The TMS470R1VF689/VF688⁽¹⁾ devices are members of the Texas Instruments TMS470R1x family of general-purpose 16/32-bit reduced instruction set computer (RISC) microcontrollers. The VF68x microcontroller offers high performance utilizing the high-speed ARM7TDMI 16/32-bit RISC central processing unit (CPU), resulting in a high instruction throughput while maintaining greater code efficiency. The ARM7TDMI 16/32-bit RISC CPU views memory as a linear collection of bytes numbered upwards from zero. The TMS470R1VF68x utilizes the big-endian format where the most significant byte of a word is stored at the lowest numbered byte and the least significant byte at the highest numbered byte.

High-end embedded control applications demand more performance from their controllers while maintaining low costs. The VF68x RISC core architecture offers solutions to these performance and cost demands while maintaining low power consumption.

The VF68x devices contain the following:

- ARM7TDMI 16/32-Bit RISC CPU
- TMS470R1x system module (SYS) with 470+ enhancements
- 384K-byte Flash (VF689 only)
- 256K-byte Flash (VF688 only)
- 16K-byte SRAM (VF689 only)
- 12K-byte SRAM (VF688 only)
- Zero-pin phase-locked loop (ZPLL) clock module
- Analog watchdog (AWD) timer
- Enhanced real-time interrupt (RTI) module
- Two serial peripheral interface (SPI) modules
- Two serial communications interface (SCI) modules
- Two standard CAN controllers (SCC)
- Class II serial interface (C2S1b)
- Three inter-integrated circuit (I2C) modules
- 10-bit multi-buffered analog-to-digital converter (MibADC), with 12 input channels
- High-end timer (HET) controlling 12 I/Os
- External Clock Prescale (ECP)
- Expansion Bus Module (EBM)
- Up to 87 I/O pins and 1 input-only pin (PGE Suffix), up to 51 I/O pins and 1 input-only pin (PZ Suffix)

The functions performed by the 470+ system module (SYS) include:

- Address decoding
- Memory protection
- Memory and peripherals bus supervision
- Reset and abort exception management
- Prioritization for all internal interrupt sources
- Device clock control
- Parallel signature analysis (PSA)

The enhanced real-time interrupt (RTI) module on the VF68x has the option to be driven by the oscillator clock. This data sheet includes device-specific information such as memory and peripheral select assignment, interrupt priority, and a device memory map. For a more detailed functional description of the SYS module, see the *TMS470R1x System Module Reference Guide* (literature number SPNU189).

The VF68x memory includes general-purpose SRAM supporting single-cycle read/write accesses in byte, half-word, and word modes.

¹ Throughout the remainder of this document, the TMS470R1VF689 and TMS470R1VF688 device names, where generic, shall be referred to as VF689/VF688 or VF68x; and, where unique, by either the full device name or VF689 or VF688.

TMS470R1VF689, TMS470R1VF688

16/32-BIT RISC FLASH MICROCONTROLLERS

SPNS001I – FEBRUARY 2002 – REVISED AUGUST 2005

description (continued)

The Flash memory on this device is a nonvolatile, electrically erasable and programmable memory implemented with a 32-bit-wide data bus interface. The Flash operates with a system clock frequency of up to 24 MHz. When in pipeline mode, the Flash operates with a system clock frequency of up to 48 MHz. For more detailed information on the Flash, see the Flash section of this data sheet and the *TMS470R1x F05 Flash Reference Guide* (literature number SPNU213).

The VF68x device has ten communication interfaces: two SPIs, two SCIs, two SCCs, a C2S1b, and three I2Cs. The SPI provides a convenient method of serial interaction for high-speed communications between similar shift-register type devices. The SCI is a full-duplex, serial I/O interface intended for asynchronous communication between the CPU and other peripherals using the standard Non-Return-to-Zero (NRZ) format. The SCC uses a serial, multimaster communication protocol that efficiently supports distributed real-time control with robust communication rates of up to 1 megabit per second (Mbps). The SCC is ideal for applications operating in noisy and harsh environments (e.g., automotive and industrial fields) that require reliable serial communication or multiplexed wiring. The C2S1b allows the VF68xB to transmit and receive messages on a class II network following an SAE Standard J1850 Class B Data Communication Network Interface standard. The I2C module is a multi-master communication module providing an interface between the VF68x microcontroller and an I2C-compatible device via the I2C serial bus. The I2C supports both 100 Kbps and 400 Kbps speeds. For more detailed functional information on the SPI, SCI, and SCC peripherals, see the specific reference guides (literature numbers SPNU195, SPNU196, and SPNU197). For more detailed functional information on the C2S1b peripheral, see the *TMS470R1x Class II Serial Interface B (C2S1b) Reference Guide* (literature number SPNU214). For more detailed functional information on the I2C, see the *TMS470R1x Inter-Integrated Circuit (I2C) Reference Guide* (literature number SPNU223).

The HET is an advanced intelligent timer that provides sophisticated timing functions for real-time applications. The timer is software-controlled, using a reduced instruction set, with a specialized timer micromachine and an attached I/O port. The HET can be used for compare, capture, or general-purpose I/O. It is especially well suited for applications requiring multiple sensor information and drive actuators with complex and accurate time pulses. For more detailed functional information on the HET, see the *TMS470R1x High-End Timer (HET) Reference Guide* (literature number SPNU199). The VF68x HET peripheral contains the XOR-share feature. This feature allows two adjacent HET high-resolution channels to be XORed together, making it possible to output smaller pulses than a standard HET. For more detailed information on the HET XOR-share feature, see the *TMS470R1x High-End Timer (HET) Reference Guide* (literature number SPNU199).

The VF68x device has one 10-bit-resolution, sample-and-hold MibADC. Each of the MibADC channels can be converted individually or can be grouped by software for sequential conversion sequences. There are three separate groupings, two of which can be triggered by an external event. Each sequence can be converted once when triggered or configured for continuous conversion mode. For more detailed functional information on the MibADC, see the *TMS470R1x Multi-Buffered Analog-to-Digital Converter (MibADC) Reference Guide* (literature number SPNU206).

The zero-pin phase-locked loop (ZPLL) clock module contains a phase-locked loop, a clock-monitor circuit, a clock-enable circuit, and a prescaler (with prescale values of 1–8). The function of the ZPLL is to multiply the external frequency reference to a higher frequency for internal use. The ZPLL provides ACLK to the system (SYS) module. The SYS module subsequently provides system clock (SYSCLK), real-time interrupt clock (RTICLK), CPU clock (MCLK), and peripheral interface clock (ICLK) to all other VF68x device modules. For more detailed functional information on the ZPLL, see the *TMS470R1x Zero-Pin Phase-Locked Loop (ZPLL) Clock Module Reference Guide* (literature number SPNU212).

NOTE

ACLK should not be confused with the MibADC internal clock, ADCLK. ACLK is the continuous system clock from an external resonator/crystal reference.

description (continued)

The Expansion Bus Module (EBM) is a standalone module that supports the multiplexing of the GIO functions and the expansion bus interface. For more information on the EBM, see the *TMS470R1x Expansion Bus Module (EBM) Reference Guide* (literature number SPNU222).

The VF68x device also has an external clock prescaler (ECP) module that when enabled, outputs a continuous external clock (ECLK) on a specified GIO pin. The ECLK frequency is a user-programmable ratio of the peripheral interface clock (ICLK) frequency. For more detailed functional information on the ECP, see the *TMS470R1x External Clock Prescaler (ECP) Reference Guide* (literature number SPNU202).

TMS470R1VF689, TMS470R1VF688

16/32-BIT RISC FLASH MICROCONTROLLERS

SPNS001I – FEBRUARY 2002 – REVISED AUGUST 2005

device characteristics

The VF68x device is a derivative of the F05 system emulation device SE470R1VB8AD. Table 1 identifies all the characteristics of the VF68x device except the SYSTEM and CPU, which are generic. The COMMENTS column aids the user in software-programming and references device-specific information.

Table 1. Device Characteristics

CHARACTERISTICS	DEVICE DESCRIPTION TMS470R1VF689/VF688	COMMENTS FOR VF689/VF688
MEMORY		
For the number of memory selects on this device, see the Memory Selection Assignment table (Table 2).		
INTERNAL MEMORY	Pipeline/Non-Pipeline	Flash is pipeline-capable
	384K-Byte Flash (VF689 only) 16K-Byte SRAM (VF689 only)	The VF689 RAM is implemented in one 16K array selected by two memory-select signals (see the TMS470R1VF689 Memory Selection Assignment table, Table 2).
	256K-Byte Flash (VF688 only) 12K-Byte SRAM (VF688 only)	The VF688 RAM is implemented in one 12K array selected by two memory-select signals (see the TMS470R1VF688 Memory Selection Assignment table, Table 3).
PERIPHERALS		
For the device-specific interrupt priority configurations, see the Interrupt Priority Table (Table 6). And for the 1K peripheral address ranges and their peripheral selects, see the VF689 Peripherals, System Module, and Flash Base Addresses table (Table 4).		
CLOCK	ZPLL	Zero-pin PLL has no external loop filter pins.
Expansion Bus	EBM	Expansion Bus Module with 40 pins. Supports 8- and 16-bit memories. PGE package only. See Table 6 for details.
GENERAL-PURPOSE I/Os	55 I/O (PGE Suffix) 14 I/O (PZ Suffix)	In the PGE package, Port A has eight (8) external pins, Port B has only one (1) external pin, Ports C, D, E, F, and G each have eight (8) external pins, and Port H has six (6) external pins. In the PZ package, Port A has eight (8) external pins, Port B has one (1) external pin, and Port H has five (5) external pins.
ECP	YES	
C2S1b	1	
SCI	2 (3-pin)	
CAN (HECC and/or SCC)	2 SCC	Standard CAN controllers
SPI (5-pin, 4-pin or 3-pin)	2 (5-pin)	
I2C	3	
HET with XOR Share	12 I/O	The high-resolution (HR) SHARE feature allows even HR pins to share the next higher odd HR pin structures. This HR sharing is independent of whether or not the odd pin is available externally. If an odd pin is available externally and <i>shared</i> , then the odd pin can only be used as a general-purpose I/O. For more information on HR SHARE, see the <i>TMS470R1x High-End Timer (HET) Reference Guide</i> (literature number SPNU199).
HET RAM	64-Instruction Capacity	
MibADC	10-bit, 12-channel 64-word FIFO	Both the logic and registers for a full 16-channel MibADC are present.
CORE VOLTAGE	1.8 V	
I/O VOLTAGE	3.3 V	
PINS	144 100	PGE and PZ packages, respectively.
PACKAGES	PGE PZ	144- and 100-pin devices, respectively.

TMS470R1VF689, TMS470R1VF688 16/32-BIT RISC FLASH MICROCONTROLLERS

SPNS0011 – FEBRUARY 2002 – REVISED AUGUST 2005

functional block diagram (VF689)

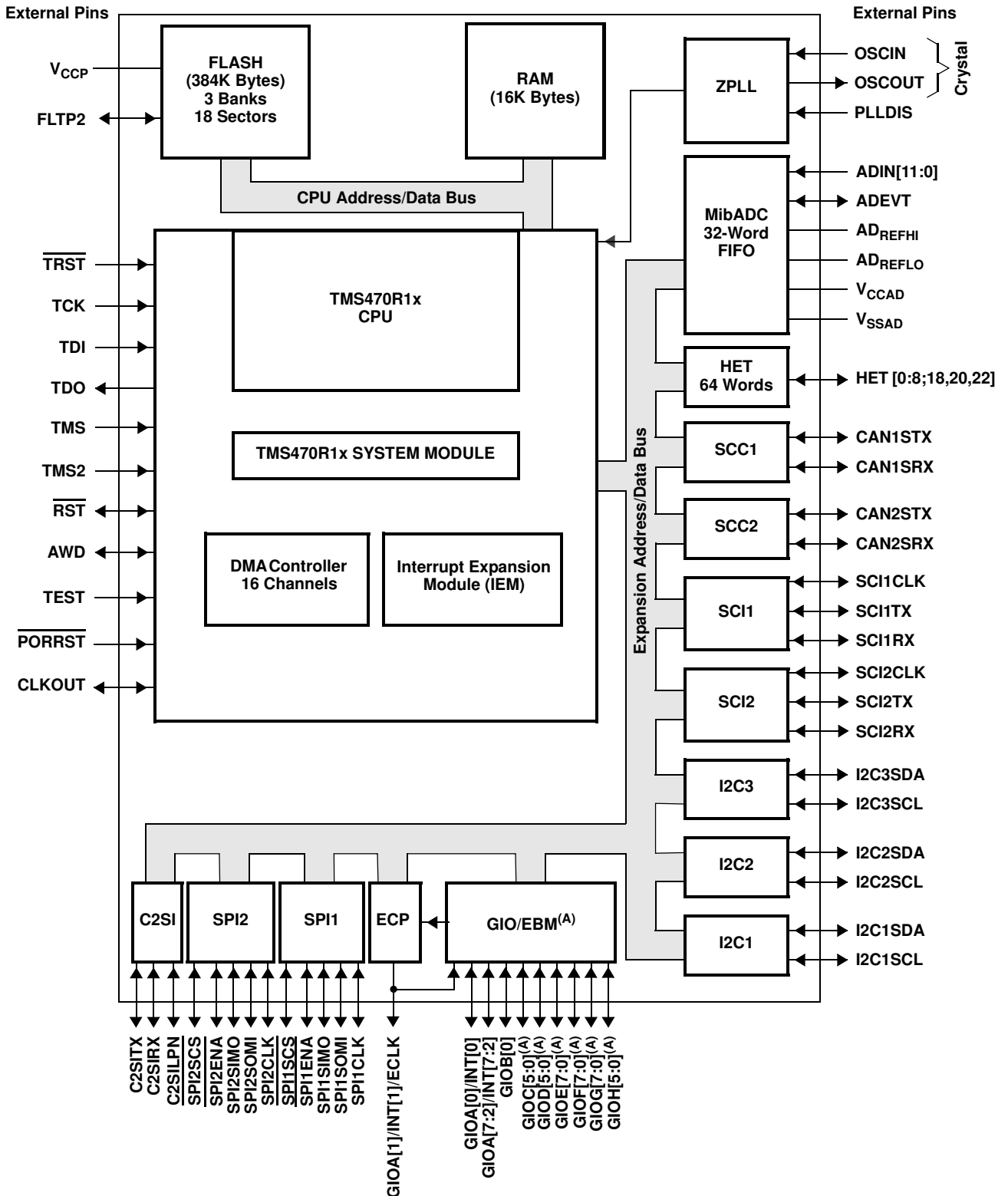

A. GIOC[4:0], GIOD[5:0], GIOE[5:0], GIOF[7:0], GIOG[5:0], and GIOH[0], which are muxed with EBM, are not available on the 100-pin package. See Table 7 for EMB to GIO mapping.

TMS470R1VF689, TMS470R1VF688 16/32-BIT RISC FLASH MICROCONTROLLERS

SPNS001I – FEBRUARY 2002 – REVISED AUGUST 2005

functional block diagram (VF688)

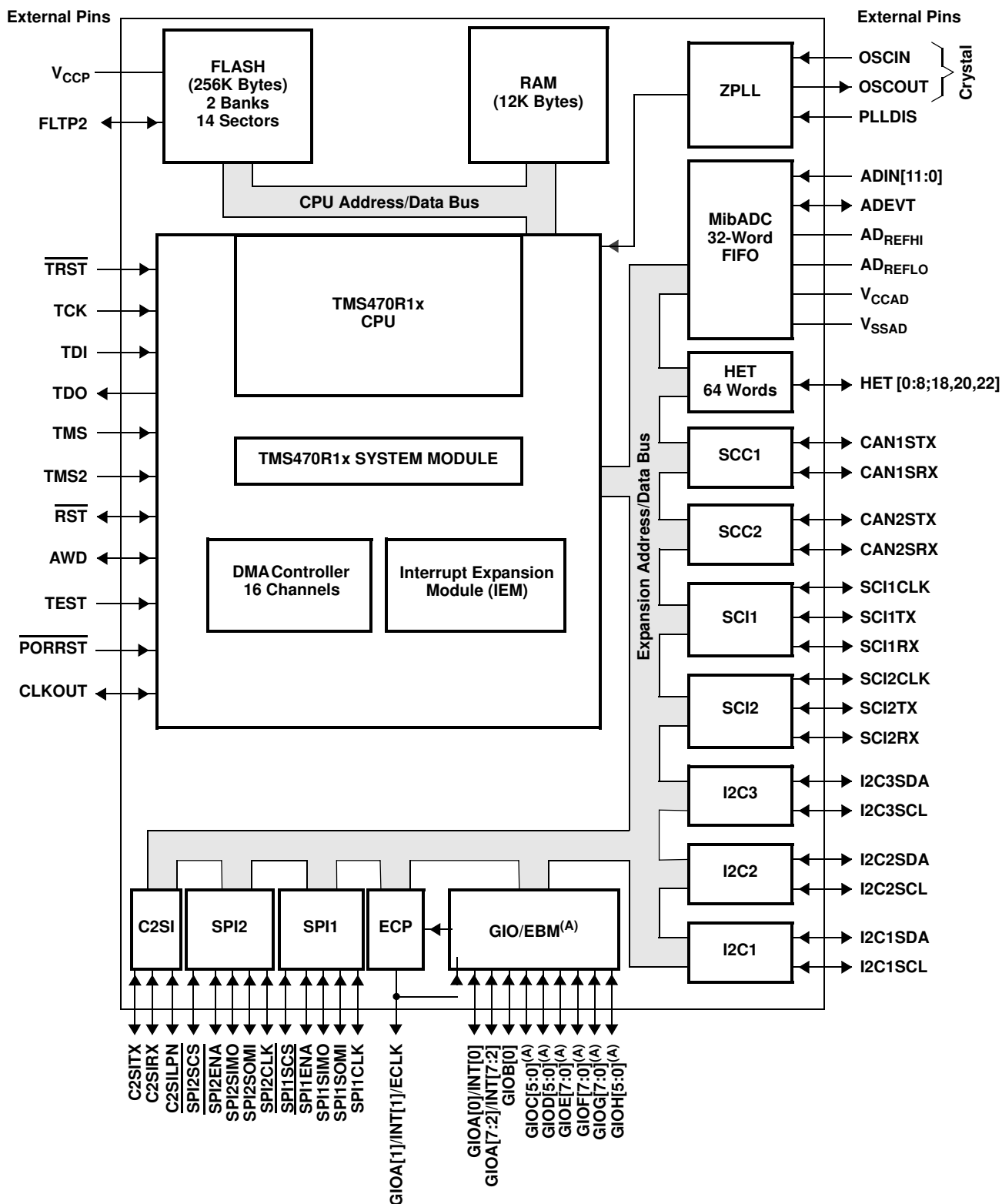

A. GIOC[4:0], GIOD[5:0], GIOE[5:0], GIOF[7:0], GIOG[5:0], and GIOH[0], which are muxed with EBM, are not available on the 100-pin package. See Table 7 for EMB to GiO mapping.

TMS470R1VF689, TMS470R1VF688

16/32-BIT RISC FLASH MICROCONTROLLERS

SPNS0011 – FEBRUARY 2002 – REVISED AUGUST 2005

Terminal Functions

TERMINAL			INPUT VOLT-AGE ⁽¹⁾⁽²⁾	OUTPUT CUR-RENT ⁽¹⁾⁽²⁾	INTERNAL PULLUP/PULL-DOWN ⁽³⁾	DESCRIPTION
NAME	PZ	PGE				
HIGH-END TIMER (HET)						
HET[0]	51	73	3.3-V	2mA		Timer input capture or output compare. The HET[8:0,18,20,22] applicable pins can be programmed as general-purpose input/output (GIO) pins. All are high-resolution pins. The high-resolution (HR) SHARE feature allows even HR pins to share the next higher odd HR pin structures. This HR sharing is independent of whether or not the odd pin is available externally. If an odd pin is available externally and <i>shared</i> , then the odd pin can only be used as a general-purpose I/O. For more information on HR SHARE, see the <i>TMS470R1x High-End Timer (HET) Reference Guide</i> (literature number SPNU199).
HET[1]	50	72				
HET[2]	49	71				
HET[3]	46	66				
HET[4]	45	65				
HET[5]	44	63				
HET[6]	6	9				
HET[7]	7	11				
HET[8]	8	12				
HET[18]	9	15				
HET[20]	12	18				
HET[22]	13	19				
STANDARD CAN CONTROLLER (SCC)						
CAN1SRX	58	83	5V tolerant	4mA		SCC1 receive pin or GIO pin
CAN1STX	59	84	3.3-V	2mA		SCC1 transmit pin or GIO pin
CAN2SRX	37	54	5V tolerant	4mA		SCC2 receive pin or GIO pin
CAN2STX	38	55	3.3-V	2mA		SCC 2transmit pin or GIO pin
CLASS II SERIAL INTERFACE (C2SIB)						
C2SibLPN	14	21	3.3-V	2mA		C2Sib module loopback enable pin or GIO pin
C2SibRX	15	22	5V tolerant	4mA		C2Sib module receive data input pin or GIO pin
C2SibTX	16	24	3.3-V	2mA		C2Sib module transmit data output pin or GIO pin
GENERAL-PURPOSE I/O (GIO)						
GIOA[0]/INT[0]	99	141	5V tolerant	4mA		General-purpose input/output pins. GIOA[7:0]/INT[7:0] are interrupt-capable pins. GIOA[1]/INT[1]/ECLK pin is multiplexed with the external clock-out function of the external clock prescale (ECP) module.
GIOA[1]/INT[1]/ECLK	96	136				
GIOA[2]/INT[2]	95	134				
GIOA[3]/INT[3]	94	133				
GIOA[4]/INT[4]	89	127				
GIOA[5]/INT[5]	67	98				
GIOA[6]/INT[6]	55	78				
GIOA[7]/INT[7]	56	79				
GIOB[0]/EBDMAREQ[0]	30	43	3.3-V	2mA	IPD	GIOB[0], GIOC[4:0], GIOD[5:0], GIOE[7:0:], GIOF[7:0], GIOG[7:0], AND GIOH[5:0] are multiplexed with the expansion bus module. See Table 7.
GIOC[0]/EBOE	–	135				
GIOC[1]/EBWR[0]	–	128				
GIOC[2]/EBWR[1]	–	126				
GIOC[3]/EBCS[5]	–	120				
GIOC[4]/EBCS[6]	–	119				

1 PWR = power, GND = ground, REF = reference voltage, NC = no connect

2 All I/O pins, except RST, are configured as inputs while PORRST is low and immediately after PORRST goes high.

3 IPD = internal pulldown, IPU = internal pullup (all internal pullups and pulldowns are active on input pins, independent of the PORRST state.)



TMS470R1VF689, TMS470R1VF688

16/32-BIT RISC FLASH MICROCONTROLLERS

SPNS001I – FEBRUARY 2002 – REVISED AUGUST 2005

Terminal Functions (Continued)

TERMINAL NAME	PZ	PGE	INPUT VOLT- AGE ⁽¹⁾⁽²⁾	OUTPUT CUR- RENT ⁽¹⁾⁽²⁾	INTERNAL PULLUP/ PULL- DOWN ⁽³⁾	DESCRIPTION
GENERAL-PURPOSE I/O (GIO) (CONTINUED)						
GIOD[0]/EBADDR[0]	–	42	3.3-V	2mA	IPD	GIOB[0], GIOC[4:0], GIOD[5:0], GIOE[7:0:], GIOF[7:0], GIOG[7:0], AND GIOH[5:0] are multiplexed with the expansion bus module. See Table 7.
GIOD[1]/EBADDR[1]	–	39				
GIOD[2]/EBADDR[2]	–	35				
GIOD[3]/EBADDR[3]	–	30				
GIOD[4]/EBADDR[4]	–	27				
GIOD[5]/EBADDR[5]	–	23				
GIOE[0]/EBDATA[0]	–	44				
GIOE[1]/EBDATA[1]	–	47				
GIOE[2]/EBDATA[2]	–	58				
GIOE[3]/EBDATA[3]	–	61				
GIOE[4]/EBDATA[4]	–	64				
GIOE[5]/EBDATA[5]	–	67				
GIOE[6]/EBDATA[6]	–	70				
GIOE[7]/EBDATA[7]	–	77				
GIOF[0]/EBADDR[6]/ EBDATA[8]	–	80				
GIOF[1]/EBADDR[7]/ EBDATA[9]	–	82				
GIOF[2]/EBADDR[8]/ EBDATA[10]	–	89				
GIOF[3]/EBADDR[9]/ EBDATA[11]	–	90				
GIOF[4]/EBADDR[10]/ EBDATA[12]	–	93				
GIOF[5]/EBADDR[11]/ EBDATA[13]	–	96				
GIOF[6]/EBADDR[12]/ EBDATA[14]	–	99				
GIOF[7]/EBADDR[12]/ EBDATA[15]	–	100				
GIOG[0]/EBADDR[14]/ EBDADDR[6]	–	20				
GIOG[1]/EBADDR[15]/ EBDADDR[7]	–	10				
GIOG[2]/EBADDR[16]/ EBDADDR[8]	–	8				
GIOG[3]/EBADDR[17]/ EBDADDR[9]	–	6				
GIOG[4]/EBADDR[18]/ EBDADDR[10]	–	3				
GIOG[5]/EBADDR[19]/ EBDADDR[11]	–	143				
GIOG[6]/EBADDR[20]/ EBDADDR[12]	–	142				
GIOG[7]/EBADDR[21]/ EBDADDR[13]	–	140				

1 PWR = power, GND = ground, REF = reference voltage, NC = no connect

2 All I/O pins, except RST, are configured as inputs while $\overline{\text{PORRST}}$ is low and immediately after $\overline{\text{PORRST}}$ goes high.

3 IPD = internal pulldown, IPU = internal pullup (all internal pullups and pulldowns are active on input pins, independent of the $\overline{\text{PORRST}}$ state.)



TMS470R1VF689, TMS470R1VF688

16/32-BIT RISC FLASH MICROCONTROLLERS

SPNS0011 – FEBRUARY 2002 – REVISED AUGUST 2005

Terminal Functions (Continued)

TERMINAL NAME	PZ	PGE	INPUT VOLT- AGE ⁽¹⁾⁽²⁾	OUTPUT CUR- RENT ⁽¹⁾⁽²⁾	INTERNAL PULLUP/ PULL- DOWN ⁽³⁾	DESCRIPTION
GENERAL-PURPOSE I/O (GIO) (CONTINUED)						
GIOH[0]/EBADDR[22]/ EBDADDR[14]	–	139	3.3-V	2mA	IPD	GIOB[0], GIOC[4:0], GIOD[5:0], GIOE[7:0:], GIOF[7:0], GIOG[7:0], AND GIOH[5:0] are multiplexed with the expansion bus module.
GIOH[1]/EBADDR[23]/ EBDADDR[15]	29	41				
GIOH[2]/EBADDR[24]/ EBDADDR[16]	28	40				
GIOH[3]/EBADDR[25]/ EBDADDR[17]	27	38				
GIOH[4]/EBADDR[26]/ EBDADDR[18]	26	37				
GIOH[5]/EBHOLD	88	125				
MULTI-BUFFERED ANALOG-TO-DIGITAL CONVERTER (MibADC)						
ADEVT	68	101	3.3-V	2mA		MibADC event input. Can be programmed as a GIO pin.
ADIN[0]	84	117	3.3-V			MibADC analog input pins
ADIN[1]	83	116				
ADIN[2]	82	115				
ADIN[3]	81	114				
ADIN[4]	80	113				
ADIN[5]	75	108				
ADIN[6]	74	107				
ADIN[7]	73	106				
ADIN[8]	72	105				
ADIN[9]	71	104				
ADIN[10]	70	103				
ADIN[11]	69	102				
AD _{REFHI}	76	109	3.3-V REF			MibADC module high-voltage reference input
AD _{REFLO}	77	110	GND REF			MibADC module low-voltage reference input
V _{CCAD}	78	111	3.3-V PWR			MibADC analog supply voltage
V _{SSAD}	79	112	GND			MibADC analog ground reference
SERIAL PERIPHERAL INTERFACE 1 (SPI1)						
SPI1CLK	3	4	5V tolerant	4mA		SPI1 clock. SPI1CLK can be programmed as a GIO pin.
SPI1ENA	2	2				SPI1 chip enable. Can be programmed as a GIO pin.
SPI1SCS	1	1				SPI1 slave chip select. Can be programmed as a GIO pin.
SPI1SIMO	4	5				SPI1 data stream. Slave in/master out. Can be programmed as a GIO pin.
SPI1SOMI	5	7				SPI1 data stream. Slave out/master in. Can be programmed as a GIO pin.
SERIAL PERIPHERAL INTERFACE 2 (SPI2)						
SPI2CLK	39	56	5V tolerant	4mA		SPI2 clock. Can be programmed as a GIO pin.
SPI2ENA	42	60				SPI2 chip enable. Can be programmed as a GIO pin.
SPI2SCS	43	62				SPI2 slave chip select. Can be programmed as a GIO pin.

1 PWR = power, GND = ground, REF = reference voltage, NC = no connect

2 All I/O pins, except RST, are configured as inputs while PORRST is low and immediately after PORRST goes high.

3 IPD = internal pulldown, IPU = internal pullup (all internal pullups and pulldowns are active on input pins, independent of the PORRST state.)



TMS470R1VF689, TMS470R1VF688

16/32-BIT RISC FLASH MICROCONTROLLERS

SPNS001I – FEBRUARY 2002 – REVISED AUGUST 2005

Terminal Functions (Continued)

TERMINAL NAME	PZ	PGE	INPUT VOLT-AGE ⁽¹⁾⁽²⁾	OUTPUT CUR-RENT ⁽¹⁾⁽²⁾	INTERNAL PULLUP/PULLDOWN ⁽³⁾	DESCRIPTION
SERIAL PERIPHERAL INTERFACE 2 (SPI2) (CONTINUED)						
SPI2SIMO	41	59	5V tolerant	4mA		SPI2 data stream. Slave in/master out. Can be programmed as a GIO pin.
SPI2SOMI	40	57				SPI2 data stream. Slave out/master in. Can be programmed as a GIO pin.
INTER-INTEGRATED CIRCUIT (I2C)						
I2C1SDA	60	87	5V tolerant	4mA		I2C1 serial data pin or GIO pin
I2C1SCL	61	88				I2C1 serial clock pin or GIO pin
I2C2SDA	64	94				I2C2 serial data pin or GIO pin
I2C2SCL	65	95				I2C2 serial clock pin or GIO pin
I2C3SDA	20	29				I2C3 serial data pin or GIO pin
I2C3SCL	19	28				I2C3 serial clock pin or GIO pin
ZERO-PIN PHASE-LOCKED LOOP (ZPLL)						
OSCIN	23	33	1.8-V			Crystal connection pin or external clock input
OSCOU	22	32		2mA		External crystal connection pin
PLLDIS	66	97	3.3-V		IPD	Enable/disable the ZPLL. The ZPLL can be bypassed and the oscillator becomes the system clock. If not in bypass mode, TI recommends that this pin be connected to ground or pulled down to ground by an external resistor.
SERIAL COMMUNICATIONS INTERFACE 1 (SCI1)						
SCI1CLK	33	48	3.3-V	2mA		SCI1 clock. SCI1CLK can be programmed as a GIO pin.
SCI1RX	32	46	5V tolerant	4mA		SCI1 data receive. SCI1RX can be programmed as a GIO pin.
SCI1TX	31	45	3.3-V	2mA		SCI1 data transmit. SCI1TX can be programmed as a GIO pin.
SERIAL COMMUNICATIONS INTERFACE 2 (SCI2)						
SCI2CLK	36	51	3.3-V	2mA		SCI2 clock. SCI2CLK can be programmed as a GIO pin.
SCI2RX	35	50	5V tolerant	4mA		SCI2 data receive. SCI2RX can be programmed as a GIO pin.
SCI2TX	34	49	3.3-V	2mA		SCI2 data transmit. SCI2TX can be programmed as a GIO pin.
SYSTEM MODULE (SYS)						
CLKOUT	57	81	3.3-V	4mA		Bidirectional pin. CLKOUT can be programmed as a GIO pin or the output of SYSCLK, ICLK, or MCLK.
$\overline{\text{PORRST}}$	85	118	3.3-V		IPD	Input master chip power-up reset. External V_{CC} monitor circuitry must assert a power-on reset.
$\overline{\text{RST}}$	86	121	3.3-V	4mA	IPU	Bidirectional reset. The internal circuitry can assert a reset, and an external system reset can assert a device reset. On this pin, the output buffer is implemented as an open drain (drives low only). To ensure an external reset is not arbitrarily generated, TI recommends that an external pullup resistor be connected to this pin.
WATCHDOG/REAL-TIME INTERRUPT (WD/RTI)						
AWD	25	36	3.3-V	4mA		Analog watchdog reset. The AWD pin provides a system reset if the WD KEY is not written in time by the system, providing an external RC network circuit is connected. If the user is not using AWD, TI recommends that this pin be connected to ground or pulled down to ground by an external resistor. For more details on the external RC network circuit, see the <i>TMS470R1x System Module Reference Guide</i> (literature number SPNU189) and the application note <i>Analog Watchdog Resistor, Capacitor and Discharge Interval Selection Constraints</i> (literature number SPNA005).

1 PWR = power, GND = ground, REF = reference voltage, NC = no connect

2 All I/O pins, except $\overline{\text{RST}}$, are configured as inputs while $\overline{\text{PORRST}}$ is low and immediately after $\overline{\text{PORRST}}$ goes high.

3 IPD = internal pulldown, IPU = internal pullup (all internal pullups and pulldowns are active on input pins, independent of the $\overline{\text{PORRST}}$ state.)



TMS470R1VF689, TMS470R1VF688 16/32-BIT RISC FLASH MICROCONTROLLERS

SPNS0011 – FEBRUARY 2002 – REVISED AUGUST 2005

Terminal Functions (Continued)

TERMINAL NAME	PZ	PGE	INPUT VOLT- AGE ⁽¹⁾⁽²⁾	OUTPUT CUR- RENT ⁽¹⁾⁽²⁾	INTERNAL PULLUP/ PULL- DOWN ⁽³⁾	DESCRIPTION
TEST/DEBUG (T/D)						
TCK	54	76	3.3-V	2mA	IPD	Test clock. TCK controls the test hardware (JTAG).
TDI	52	74		2mA	IPU	Test data in. TDI inputs serial data to the test instruction register, test data register, and programmable test address (JTAG).
TDO	53	75		4mA	IPD	Test data out. TDO outputs serial data from the test instruction register, test data register, identification register, and programmable test address (JTAG).
TEST	87	124			IPD	Test enable. Reserved for internal use only. TI recommends that this pin be connected to ground or pulled down to ground by an external resistor.
TMS	11	17		2mA	IPU	Serial input for controlling the state of the CPU test access port (TAP) controller (JTAG).
TMS2	10	16		2mA	IPU	Serial input for controlling the second TAP. TI recommends that this pin be connected to V _{CCIO} or pulled up to V _{CCIO} by an external resistor.
$\overline{\text{TRST}}$	100	144			IPD	Test hardware reset to TAP1 and TAP2. IEEE Standard 1149-1 (JTAG) Boundary-Scan Logic. TI recommends that this pin be pulled down to ground by an external resistor.
FLASH						
FLTP2	93	132	NC	NC		Flash test pad 2. For proper operation, this pin must not be connected [no connect (NC)].
V _{CCP}	92	131	3.3-V PWR			Flash external pump voltage (3.3 V)
SUPPLY VOLTAGE CORE (1.8 V)						
V _{CC}	21	13	1.8-V PWR			Core logic supply voltage
	63	31				
	91	53				
	–	92				
	–	123				
	–	130				
SUPPLY VOLTAGE DIGITAL I/O (3.3 V)						
V _{CCIO}	17	25	3.3-V PWR			Digital I/O supply voltage
	48	69				
	–	86				
	97	137				
SUPPLY GROUND						
V _{SS}	90	14	GND			Supply ground reference
	98	26				
	–	34				
	–	52				
	–	68				
	47	85				
	–	91				
	62	122				
	24	129				
18	138					

1 PWR = power, GND = ground, REF = reference voltage, NC = no connect

2 All I/O pins, except RST, are configured as inputs while $\overline{\text{PORRST}}$ is low and immediately after $\overline{\text{PORRST}}$ goes high.

3 IPD = internal pulldown, IPU = internal pullup (all internal pullups and pulldowns are active on input pins, independent of the $\overline{\text{PORRST}}$ state.)



TMS470R1VF689, TMS470R1VF688 16/32-BIT RISC FLASH MICROCONTROLLERS

SPNS001I – FEBRUARY 2002 – REVISED AUGUST 2005

VF689/VF688 DEVICE-SPECIFIC INFORMATION

memory (VF689)

Figure 1 shows the memory map of the VF689 device.

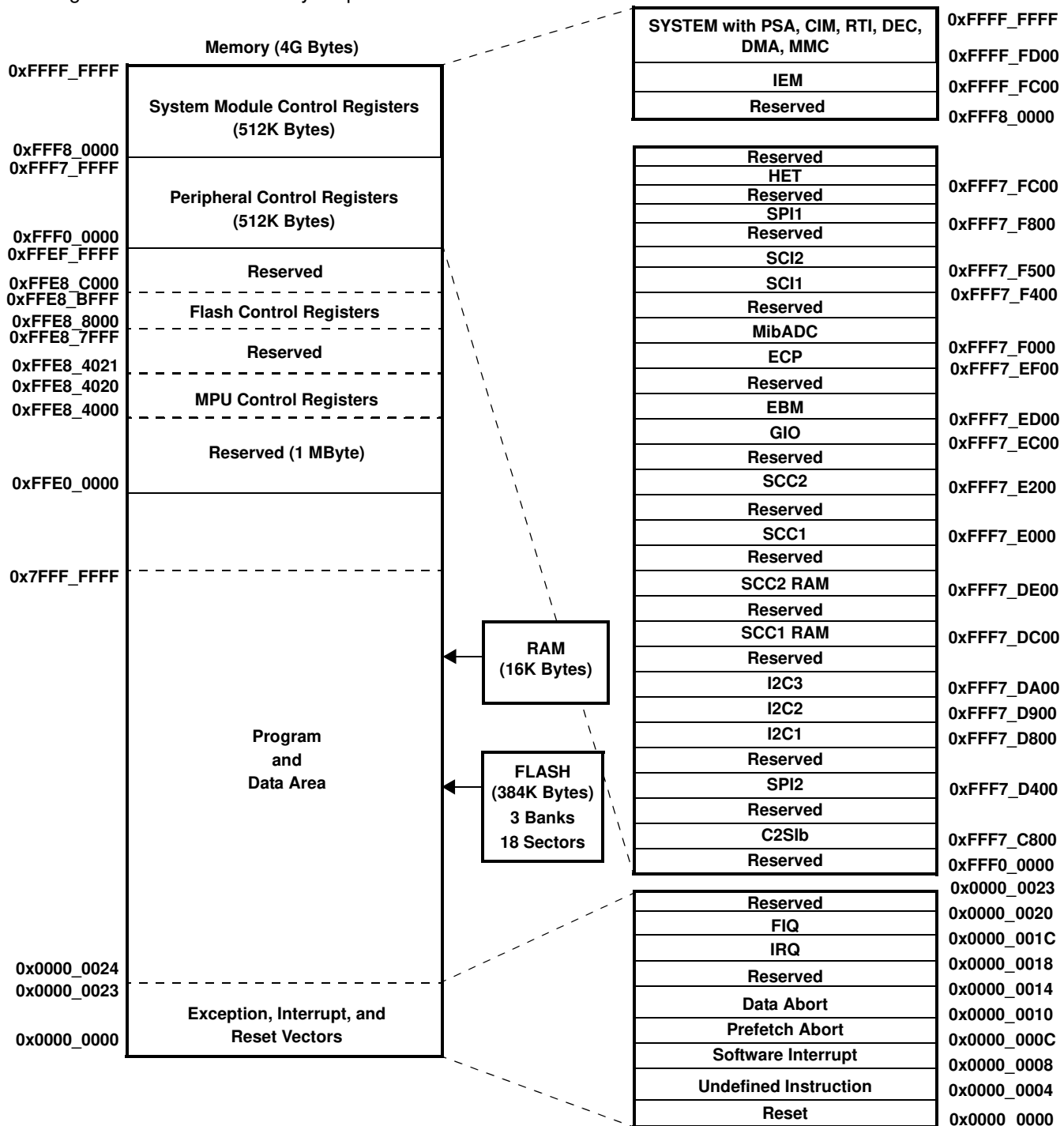

- A. Memory addresses are configurable by the system (SYS) module within the range of 0x0000_0000 to 0xFFE0_0000.
- B. The CPU registers are not a part of the memory map.

Figure 1. TMS470R1VF689 Memory Map



TMS470R1VF689, TMS470R1VF688

16/32-BIT RISC FLASH MICROCONTROLLERS

SPNS001I – FEBRUARY 2002 – REVISED AUGUST 2005

memory selects

Memory selects allow the user to address memory arrays (i.e., Flash, RAM, and HET RAM) at user-defined addresses. Each memory select has its own set (low and high) of memory base address registers (MFBAHRx and MFBALRx) that, together, define the array's starting (base) address, size, and protection.

The base address of each memory select is configurable to any memory address boundary that is a multiple of the decoded block size. The decoded block size for the flash memory on this device is 0x00100000. For more information on how to control and configure these memory select registers, see the bus structure and memory sections of the *TMS470R1x System Module Reference Guide* (literature number SPNU189).

For the memory selection assignments and the memory selected, see Table 2 and Table 3.

Table 2. TMS470R1VF689 Memory Selection Assignment

MEMORY SELECT	MEMORY SELECTED (ALL INTERNAL)	MEMORY SIZE ⁽¹⁾	MPU	MEMORY BASE ADDRESS REGISTER	STATIC MEM CTL REGISTER
0 (fine)	FLASH	384K	NO	MFBAHR0 and MFBALR0	
1 (fine)	FLASH		NO	MFBAHR1 and MFBALR1	
2 (fine)	RAM	16K ⁽²⁾	YES	MFBAHR2 and MFBALR2	
3 (fine)	RAM		YES	MFBAHR3 and MFBALR3	
4 (fine)	HET RAM	1K	NO	MFBAHR4 and MFBALR4	SMCR1
5 (fine)	$\overline{CS[5]}$ /GIOC[3]	256MB (x8) 1M (x16)	NO	MCBAHR2 and MCBALR2	SMCR5
6 (fine)	$\overline{CS[6]}$ /GIOC[4]	256MB (x8) 1M (x16)	NO	MCBAHR3 and MCBALR3	SMCR6

1 x8 refers to size of memory in 8-bits; x16 refers to size of memory in 16-bits.

2 The starting addresses for both RAM memory-select signals *cannot* be offset from each other by a multiple of the user-defined block size in the memory-base address register.

Table 3. TMS470R1VF688 Memory Selection Assignment

MEMORY SELECT	MEMORY SELECTED (ALL INTERNAL)	MEMORY SIZE ⁽³⁾	MPU	MEMORY BASE ADDRESS REGISTER	STATIC MEM CTL REGISTER
0 (fine)	FLASH	256K	NO	MFBAHR0 and MFBALR0	
1 (fine)	FLASH		NO	MFBAHR1 and MFBALR1	
2 (fine)	RAM	12K ⁽⁴⁾	YES	MFBAHR2 and MFBALR2	
3 (fine)	RAM		YES	MFBAHR3 and MFBALR3	
4 (fine)	HET RAM	1K	NO	MFBAHR4 and MFBALR4	SMCR1
5 (fine)	$\overline{CS[5]}$ /GIOC[3]	256MB (x8) 1M (x16)	NO	MCBAHR2 and MCBALR2	SMCR5
6 (fine)	$\overline{CS[6]}$ /GIOC[4]	256MB (x8) 1M (x16)	NO	MCBAHR3 and MCBALR3	SMCR6

3 x8 refers to size of memory in 8-bits; x16 refers to size of memory in 16-bits.

4 The starting addresses for both RAM memory-select signals *cannot* be offset from each other by a multiple of the user-defined block size in the memory-base address register.

RAM

The VF689 device contains 16K-bytes of internal static RAM configurable by the SYS module to be addressed within the range of 0x0000_0000 to 0xFFE0_0000. This VF689 RAM is implemented in one 16K array selected by two memory-select signals. The VF688 device contains 12K-bytes of internal static RAM configurable by the SYS module to be addressed within the range of 0x0000_0000 to 0xFFE0_0000. This VF688 RAM is implemented in one 12K array selected by two memory-select signals. This VF68x configuration imposes an additional constraint on the memory map for RAM; the starting addresses for both RAM memory selects *cannot* be offset from each other by the multiples of the size of the physical RAM (i.e., 16K for the VF689 device). The VF68x RAM is addressed through memory selects 2 and 3.

The RAM can be protected by the memory protection unit (MPU) portion of the SYS module, allowing the user finer blocks of memory protection than is allowed by the memory selects. The MPU is ideal for protecting an operating system while allowing access to the current task. For more detailed information on the MPU portion of the SYS module and memory protection, see the memory section of the *TMS470R1x System Module Reference Guide* (literature number SPNU189).

F05 Flash

The F05 Flash memory is a nonvolatile electrically erasable and programmable memory implemented with a 32-bit-wide data bus interface. The F05 Flash has an external state machine for programming and erase functions. See the *Flash read* and *Flash program and erase* sections below.

Flash protection keys

The VF68x device provides Flash protection keys. These four 32-bit protection keys prevent program/erase/compaction operations from occurring until after the four protection keys have been matched by the CPU loading the correct user keys into the FMPKEY control register. The protection keys on the VF68x are located in the last 4 words of the first 8K sector. For more detailed information on the Flash protection keys and the FMPKEY control register, see the Optional Quadruple Protection Keys and Programming the Protection Keys portions of the *TMS470R1x F05 Flash Reference Guide* (literature number SPNU213).

Flash read

The VF68x Flash memory is configurable by the SYS module to be addressed within the range of 0x0000_0000 to 0xFFE0_0000. The Flash is addressed through memory selects 0 and 1.

Note: The Flash external pump voltage (V_{CCP}) is required for all operations (program, erase, and read).

Flash pipeline mode

When in pipeline mode, the Flash operates with a system clock frequency of up to 48 MHz (versus a system clock frequency of 24 MHz in normal mode). Flash in pipeline mode is capable of accessing 64-bit words and provides two 32-bit pipelined words to the CPU. Also, in pipeline mode the Flash can be read with no wait states when memory addresses are contiguous (after the initial 1- or 2-wait-state reads).

Note: After a system reset, pipeline mode is disabled (ENPIPE bit [FMREGOPT.0] is a "0"). In other words, the VF689/VF688 device powers up and comes out of reset in non-pipeline mode. Furthermore, setting the Flash configuration mode bit (GBLCTRL.4) will override pipeline mode.

TMS470R1VF689, TMS470R1VF688

16/32-BIT RISC FLASH MICROCONTROLLERS

SPNS001I – FEBRUARY 2002 – REVISED AUGUST 2005

Flash program and erase

The VF689 device Flash contains three 128K-byte memory arrays (or banks), for a total of 384K-bytes of Flash, and consists of eighteen sectors. These eighteen sectors are sized as follows:

SECTOR NO.	SEGMENT	LOW ADDRESS	HIGH ADDRESS	MEMORY ARRAYS (OR BANKS)
0	8K Bytes	0x0000_0000	0x0000_1FFF	BANK0 (128K Bytes)
1	8K Bytes	0x0000_2000	0x0000_3FFF	
2	16K Bytes	0x0000_4000	0x0000_7FFF	
3	16K Bytes	0x0000_8000	0x0000_BFFF	
4	16K Bytes	0x0000_C000	0x0000_FFFF	
5	16K Bytes	0x0001_0000	0x0001_3FFF	
6	16K Bytes	0x0001_4000	0x0001_7FFF	
7	16K Bytes	0x0001_8000	0x0001_BFFF	
8	8K Bytes	0x0001_C000	0x0001_DFFF	
9	8K Bytes	0x0001_E000	0x0001_FFFF	
0	32K Bytes	0x0002_0000	0x0002_7FFF	BANK1 (128K Bytes)
1	32K Bytes	0x0002_8000	0x0002_FFFF	
2	32K Bytes	0x0003_0000	0x0003_7FFF	
3	32K Bytes	0x0003_8000	0x0003_FFFF	
0	32K Bytes	0x0004_0000	0x0004_7FFF	BANK2 (128K Bytes)
1	32K Bytes	0x0004_8000	0x0004_FFFF	
2	32K Bytes	0x0005_0000	0x0005_7FFF	
3	32K Bytes	0x0005_8000	0x0005_FFFF	

The VF688 device Flash contains two 128K-byte memory arrays (or banks), for a total of 256K-bytes of Flash, and consists of fourteen sectors. These fourteen sectors are sized as follows:

SECTOR NO.	SEGMENT	LOW ADDRESS	HIGH ADDRESS	MEMORY ARRAYS (OR BANKS)
0	8K Bytes	0x0000_0000	0x0000_1FFF	BANK0 (128K Bytes)
1	8K Bytes	0x0000_2000	0x0000_3FFF	
2	16K Bytes	0x0000_4000	0x0000_7FFF	
3	16K Bytes	0x0000_8000	0x0000_BFFF	
4	16K Bytes	0x0000_C000	0x0000_FFFF	
5	16K Bytes	0x0001_0000	0x0001_3FFF	
6	16K Bytes	0x0001_4000	0x0001_7FFF	
7	16K Bytes	0x0001_8000	0x0001_BFFF	
8	8K Bytes	0x0001_C000	0x0001_DFFF	
9	8K Bytes	0x0001_E000	0x0001_FFFF	
0	32K Bytes	0x0002_0000	0x0002_7FFF	BANK1 (128K Bytes)
1	32K Bytes	0x0002_8000	0x0002_FFFF	
2	32K Bytes	0x0003_0000	0x0003_7FFF	
3	32K Bytes	0x0003_8000	0x0003_FFFF	

The minimum size for an erase operation is one sector. The maximum size for a program operation is one 16-bit word.



flash program and erase (continued)

NOTE

The flash external pump voltage (V_{CCP}) is required for all operations (program, erase, and read).

Execution can occur from one bank while programming/erasing any or all sectors of another bank. However, execution can not occur from any sector within a bank that is being programmed or erased.

NOTE

When the OTP sector is enabled, the rest of the flash memory is disabled. The OTP memory can only be read or programmed from code executed out of RAM.

For more detailed information on Flash program and erase operations, see the *TMS470R1x F05 Flash Reference Guide* (literature number SPNU213).

HET RAM

The VF68x device contains HET RAM. The HET RAM has a 64-instruction capability. The HET RAM is configurable by the SYS module to be addressed within the range of 0x0000_0000 to 0xFFE0_0000. The HET RAM is addressed through memory select 4.

TMS470R1VF689, TMS470R1VF688

16/32-BIT RISC FLASH MICROCONTROLLERS

SPNS001I – FEBRUARY 2002 – REVISED AUGUST 2005

peripheral selects and base addresses

The VF68x device uses ten of the sixteen peripheral selects to decode the base addresses of the peripherals. These peripheral selects are fixed and transparent to the user since they are part of the decoding scheme used by the SYS module.

Control registers for the peripherals, SYS module, and Flash begin at the base addresses shown in Table 4.

Table 4. VF689/VF688 Peripherals, System Module, and Flash Base Addresses

CONNECTING MODULE	ADDRESS RANGE		PERIPHERAL SELECTS
	BASE ADDRESS	ENDING ADDRESS	
SYSTEM	0xFFFF_FFCC	0xFFFF_FFFF	N/A
RESERVED	0xFFFF_FF60	0xFFFF_FFCB	N/A
PSA	0xFFFF_FF40	0xFFFF_FF5F	N/A
CIM	0xFFFF_FF20	0xFFFF_FF3F	N/A
RTI	0xFFFF_FF00	0xFFFF_FF1F	N/A
DMA	0xFFFF_FE80	0xFFFF_FEFF	N/A
DEC	0xFFFF_FE00	0xFFFF_FE7F	N/A
MMC	0xFFFF_FD00	0xFFFF_FD7F	N/A
IEM	0xFFFF_FC00	0xFFFF_FCFE	N/A
RESERVED	0xFFFF_FB00	0xFFFF_FBFF	N/A
RESERVED	0xFFFF_FA00	0xFFFF_FAFF	N/A
DMA CMD BUFFER	0xFFFF_F800	0xFFFF_F9FF	N/A
RESERVED	0xFFF8_0000	0xFFF8_7FFF	N/A
HET	0xFFF7_FC00	0xFFF7_FFFF	PS[0]
SPI1	0xFFF7_F800	0xFFF7_FBFF	PS[1]
SCI2	0xFFF7_F500	0xFFF7_F7FF	PS[2]
SCI1	0xFFF7_F400	0xFFF7_F4FF	
MIBADC	0xFFF7_F000	0xFFF7_F3FF	PS[3]
ECP	0xFFF7_EF00	0xFFF7_EFFF	PS[4]
RESERVED	0xFFF7_EE00	0xFFF7_EEFF	
EBM	0xFFF7_ED00	0xFFF7_EDFF	
GIO	0xFFF7_EC00	0xFFF7_ECFE	
RESERVED	0xFFF7_E400	0xFFF7_EBFF	PS[5] - PS[6]
RESERVED	0xFFF7_E300	0xFFF7_E3FF	PS[7]
SCC2	0xFFF7_E200	0xFFF7_E2FF	
RESERVED	0xFFF7_E100	0xFFF7_E1FF	
SCC1	0xFFF7_E000	0xFFF7_E0FF	
RESERVED	0xFFF7_DF00	0xFFF7_DFFF	PS[8]
SCC2 RAM	0xFFF7_DE00	0xFFF7_DEFF	
RESERVED	0xFFF7_DD00	0xFFF7_DDFF	
SCC1 RAM	0xFFF7_DC00	0xFFF7_DCFE	
RESERVED	0xFFF7_DB00	0xFFF7_DBFF	PS[9]
I2C3	0xFFF7_DA00	0xFFF7_DAFF	
I2C2	0xFFF7_D900	0xFFF7_D9FF	
I2C1	0xFFF7_D800	0xFFF7_D8FF	PS[10]
SPI2	0xFFF7_D400	0xFFF7_D7FF	
RESERVED	0xFFF7_CC00	0xFFF7_D3FF	PS[11] - PS[12]
C2SIB	0xFFF7_C800	0xFFF7_CBFF	PS[13]
RESERVED	0xFFF7_C000	0xFFF7_C7FF	PS[14] - PS[15]
RESERVED	0xFFF0_0000	0xFFF7_BFFF	N/A
FLASH CONTROL REGISTERS	0xFFE8_8000	0xFFE8_BFFF	N/A
MPU CONTROL REGISTERS	0xFFE8_4000	0xFFE8_4023	N/A

direct-memory access (DMA)

The direct-memory access (DMA) controller transfers data to and from any specified location in the VF68x memory map (except for restricted memory locations like the system control registers area). The DMA manages up to 16 channels, and supports data transfer for both on-chip and off-chip memories and peripherals. The DMA controller is connected to both the CPU and Peripheral busses, enabling these data transfers to occur in parallel with CPU activity and thus, maximizing overall system performance.

Although the DMA controller has two possible configurations, for the VF68x device, the DMA controller configuration is 32 control packets and 16 channels.

For the VF68x DMA request hardwired configuration, see Table 5.

Table 5. DMA Request Lines Connections⁽¹⁾

MODULES	DMA REQUEST INTERRUPT SOURCES		DMA CHANNEL
EBM	Expansion Bus DMA request	EBDMAREQ0	DMAREQ[0]
SPI1	SPI1 end-receive	SPI1DMA0	DMAREQ[1]
SPI1	SPI1 end-transmit	SPI1DMA1	DMAREQ[2]
I2C1	I2C1 read	I2C1DMA0	DMAREQ[3]
SCI1	SCI1 end-receive	SCI1DMA0	DMAREQ[4]
SCI1	SCI1 end-transmit	SCI1DMA1	DMAREQ[5]
I2C1	I2C1 write	I2C1DMA1	DMAREQ[6]
SPI2	SPI2 end-receive	SPI2DMA0	DMAREQ[7]
SPI2	SPI2 end-transmit	SPI2DMA1	DMAREQ[8]
I2C2/C2S1b	I2C2 read/C2S1b end-receive	I2C2DMA0/C2SIDMA0	DMAREQ[9]
I2C2/C2S1b	I2C2 write/C2S1b end-transmit	I2C2DMA1/C2SIDMA1	DMAREQ[10]
I2C3	I2C3 read	I2C3DMA0	DMAREQ[11]
I2C3	I2C3 write	I2C3DMA1	DMAREQ[12]
Reserved			DMAREQ[13]
SCI2/SPI3	SCI2 end-receive	SCI2DMA0	DMAREQ[14]
SCI2/SPI3	SCI2 end-transmit	SCI2DMA1	DMAREQ[15]

¹ For DMA channels with more than one assigned request source (I2C2/S2S1b), *only one* of the sources listed can be the DMA request generator in a given application. The device has software control to ensure that there are no conflicts between requesting modules.

Each channel has two control packets attached to it, allowing the DMA to continuously load RAM and generate periodic interrupts so that the data can be read by the CPU. The control packets allow for the interrupt enable, and the channels determine the priority level of the interrupt.

DMA transfers occur in one of two modes:

- Non-request mode (used when transferring from memory to memory)
- Request mode (used when transferring from memory to peripheral)

For more detailed functional information on the DMA controller, see the *TMS470R1x Direct Memory Access (DMA) Controller Reference Guide* (literature number SPNU194).

TMS470R1VF689, TMS470R1VF688

16/32-BIT RISC FLASH MICROCONTROLLERS

SPNS0011 – FEBRUARY 2002 – REVISED AUGUST 2005

interrupt priority (IEM to CIM)

Interrupt requests originating from the VF68x peripheral modules (i.e., SPI1 or SPI2; SCI1 or SCI2; SCC1 or SCC2; RTI; etc.) are assigned to channels within the 48-channel interrupt expansion module (IEM) where, via programmable register mapping, these channels are then mapped to the 32-channel central interrupt manager (CIM) portion of the SYS module.

Programming multiple interrupt sources in the IEM to the same CIM channel effectively shares the CIM channel between sources.

The CIM request channels are maskable so that individual channels can be selectively disabled. All interrupt requests can be programmed in the CIM to be of either type:

- Fast interrupt request (FIQ)
- Normal interrupt request (IRQ)

The CIM prioritizes interrupts. The precedences of request channels decrease with ascending channel order in the CIM (0 [highest] and 31 [lowest] priority). For IEM-to-CIM default mapping, channel priorities, and their associated modules, see Table 6.

Table 6. Interrupt Priority (IEM and CIM)

MODULES	INTERRUPT SOURCES	DEFAULT CIM INTERRUPT LEVEL/ CHANNEL	IEM CHANNEL
SPI1	SPI1 end-transfer/overrun	0	0
RTI	COMP2 interrupt	1	1
RTI	COMP1 interrupt	2	2
RTI	TAP interrupt	3	3
SPI2	SPI2 end-transfer/overrun	4	4
GIO	GIO interrupt A	5	5
RESERVED		6	6
HET	HET interrupt 1	7	7
I2C1	I2C1 interrupt	8	8
SCI1/SCI2	SCI1 or SCI2 error interrupt	9	9
SCI1	SCI1 receive interrupt	10	10
C2S1b	C2S1b interrupt	11	11
I2C2	I2C2 interrupt	12	12
SCC2	SCC2 interrupt A	13	13
SCC1	SCC1 interrupt A	14	14
RESERVED		15	15
MibADC	MibADC end event conversion	16	16
SCI2	SCI2 receive interrupt	17	17
DMA	DMA interrupt 0	18	18
I2C3	I2C3 interrupt	19	19
SCI1	SCI1 transmit interrupt	20	20
System	SW interrupt (SSI)	21	21
RESERVED		22	22
HET	HET interrupt 2	23	23
SCC2	SCC2 interrupt B	24	24
SCC1	SCC1 interrupt B	25	25

TMS470R1VF689, TMS470R1VF688 16/32-BIT RISC FLASH MICROCONTROLLERS

SPNS0011 – FEBRUARY 2002 – REVISED AUGUST 2005

interrupt priority (IEM to CIM) (continued)

Table 6. Interrupt Priority (IEM and CIM) (Continued)

MODULES	INTERRUPT SOURCES	DEFAULT CIM INTERRUPT LEVEL/ CHANNEL	IEM CHANNEL
SCI2	SCI2 transmit interrupt	26	26
MibADC	MibADC end Group 1 conversion	27	27
DMA	DMA Interrupt 1	28	28
GIO	GIO interrupt B	29	29
MibADC	MibADC end Group 2 conversion	30	30
RESERVED		31	31
RESERVED		31	32
RESERVED		31	33
RESERVED		31	34
RESERVED		31	35
RESERVED		31	36
RESERVED		31	37
RESERVED		31	38
RESERVED		31	39
RESERVED		31	40
RESERVED		31	41
RESERVED		31	42
RESERVED		31	43
RESERVED		31	44
RESERVED		31	45
RESERVED		31	46
RESERVED		31	47

For more detailed functional information on the IEM, see the *TMS470R1x Interrupt Expansion Module (IEM) Reference Guide* (literature number SPNU211). For more detailed functional information on the CIM, see the *TMS470R1x System Module Reference Guide* (literature number SPNU189).

TMS470R1VF689, TMS470R1VF688

16/32-BIT RISC FLASH MICROCONTROLLERS

SPNS001I – FEBRUARY 2002 – REVISED AUGUST 2005

expansion bus module (EBM)

The Expansion Bus Module (EBM) is a standalone module used to bond out both general-purpose input/output pins and expansion bus interface pins. This module supports the multiplexing of the GIO functions and the expansion bus interface functions. The module also supports 8- and 16- bit expansion bus memory interface mappings as well as mapping of the following expansion bus signals:

- 27-bit address bus (EBADDR[26:0]) for x8, 19-bit address bus (EBADDR[18:0]) for x16
- 8- or 16-bit data bus (EBDATA[7:0] or EBDATA[15:0])
- 2 write strobes ($\overline{\text{EBWR}}[1:0]$)
- 2 memory chip selects ($\overline{\text{EBCS}}[6:5]$)
- 1 output enable ($\overline{\text{EBOE}}$)
- 1 external hold signal for interfacing to slow memories ($\overline{\text{EBHOLD}}$)
- 1 DMA request line (EBDMAREQ[0])

Table 6 shows the mapping of GIO ports B, C, D, E, F, G and H with the expansion bus module. The mapping of these pins varies depending on the memory mode.

Table 7. Expansion Bus Mux Mapping⁽¹⁾

GIO	EXPANSION BUS MODULE PINS ⁽²⁾	
	X8	X16
GIOB[0]	EBDMAREQ[0]	EBDMAREQ[0]
GIOC[0]	$\overline{\text{EBOE}}$	$\overline{\text{EBOE}}$
GIOC[2:1]	$\overline{\text{EBWR}}[1:0]$	$\overline{\text{EBWR}}[1:0]$
GIOC[4:3]	$\overline{\text{EBCS}}[6:5]$	$\overline{\text{EBCS}}[6:5]$
GIOD[5:0]	EBADDR[5:0]	EBADDR[5:0]
GIOE[7:0]	EBDATA[7:0]	EBDATA[7:0]
GIOF[7:0]	EBADDR[13:6]	EBDATA[15:8]
GIOG[7:0]	EBADDR[21:14]	EBADDR[13:6]
GIOH[4:0]	EBADDR[26:22]	EBADDR[18:14]
GIOH[5]	$\overline{\text{EBHOLD}}$	$\overline{\text{EBHOLD}}$

1 These mappings are controlled by the EBM mux control registers B-H (EBMXCRB - EBMXCRH) and the EBM control register 1 (EBMCR1). For GPIO functions, use GIODIRx, GIODINx, GIODOUTx, GIODSETx, and GIODCLR. For more detailed information, see the *TMS470R1x General-Purpose Input/Output (GIO) Reference Guide* (literature number SPNU192) and the *TMS470R1x Expansion Bus Module (EBM) Reference Guide* (literature number SPNU222).

2 X8 refers to size of memory in 8-bits; X16 refers to size of memory in 16-bits.

Table 7 lists the names of the expansion bus module pins and their functions.

Table 8. Expansion Bus Pins

PIN	DESCRIPTION
EBDMAREQ	Expansion bus DMA request
$\overline{\text{EBOE}}$	Expansion bus pin enable
$\overline{\text{EBWR}}$	Expansion bus write strobe. $\overline{\text{EBWR}}[1]$ controls EBDATA[15:8] and $\overline{\text{EBWR}}[0]$ controls EBDATA[7:0]
$\overline{\text{EBCS}}$	Expansion bus chip select
EBADDR	Expansion bus address pin
EBDATA	Expansion bus data pin
$\overline{\text{EBHOLD}}$	Expansion bus hold. An external device may assert this signal to add wait states to an expansion bus transaction.

MibADC

The multi-buffered analog-to-digital converter (MibADC) accepts an analog signal and converts the signal to a 10-bit digital value.

The VF68x MibADC module can function in two modes: compatibility mode, where it's programmer's model is compatible with the TMS470R1x ADC module and its digital results are stored in digital result registers; or in buffered mode, where the digital result registers are replaced with three FIFO buffers, one for each conversion group [event, group1 (G1), and group2 (G2)]. In buffered mode, the MibADC buffers can be serviced by interrupts.

NOTE:

The MibADC on this device does not support the DMA.

MibADC event trigger enhancements

The MibADC includes two major enhancements over the event-triggering capability of the TMS470R1x ADC.

- Both group 1 and the event group can be configured for event-triggered operation, providing up to two event-triggered groups.
- The trigger source and polarity can be selected individually for both group 1 and the event group from the options identified in Table 9.

Table 9. MibADC Event Hookup Configuration

EVENT #	SOURCE SELECT BITS FOR G1 OR EVENT (G1SRC[1:0] or EVSRC[1:0])	SIGNAL PIN NAME
EVENT1	00	ADEV1
EVENT2	01	HET18
EVENT3	10	RESERVED
EVENT4	11	RESERVED

For group 1, these event-triggered selections are configured via the group 1 source select bits (G1SRC[1:0]) in the AD event source register (ADEVTSRC.[5:4]). For the event group, these event-triggered selections are configured via the event group source select bits (EVSRC[1:0]) in the AD event source register (ADEVTSRC.[1:0]).

For more detailed functional information on the MibADC, see the *TMS470R1x Multi-Buffered Analog-to-Digital Converter (MibADC) Reference Guide* (literature number SPNU206).

TMS470R1VF689, TMS470R1VF688

16/32-BIT RISC FLASH MICROCONTROLLERS

SPNS001I – FEBRUARY 2002 – REVISED AUGUST 2005

development system support

Texas Instruments provides extensive hardware and software development support tools for the TMS470R1x family. These support tools include:

- Code Composer Studio™ Integrated Development Environment (IDE)
 - Fully integrated suite of software development tools
 - Includes Compiler/Assembler/Linker, Debugger, and Simulator
 - Supports Real-Time analysis, data visualization, and open API
- Optimizing C compiler
 - Supports high-level language programming
 - Full implementation of the standard ANSI C language
 - Powerful optimizer that improves code-execution speed and reduces code size
 - Extensive run-time support library included
 - TMS470R1x control registers easily accessible from the C program
 - Interfaces C functions and assembly functions easily
 - Establishes comprehensive, easy-to-use tool set for the development of high-performance microcontroller applications in C/C++
- Assembly language tools (assembler and linker)
 - Provides extensive macro capability
 - Allows high-speed operation
 - Allows extensive control of the assembly process using assembler directives
 - Automatically resolves memory references as C and assembly modules are combined
- TMS470R1x CPU Simulator
 - Provides capability to simulate CPU operation without emulation hardware
 - Allows inspection and modifications of memory locations
 - Allows debugging programs in C or assembly language
- XDS emulation communication kits
 - Allow high-speed JTAG communication to the TMS470R1x emulator or target board

For information on pricing and availability, contact the nearest TI field sales office or authorized distributor.

Code Composer Studio is a trademark of Texas Instruments.



documentation support

Extensive documentation supports all of the TMS470 microcontroller family generation of devices. The types of documentation available include: data sheets with design specifications; complete user's guides for all devices and development support tools; and hardware and software applications. Useful reference documentation includes:

- Users Guides
 - *TMS470R1x 32-Bit RISC Microcontroller Family User's Guide* (literature number SPNU134)
 - *TMS470R1x C/C++ Compiler User's Guide* (literature number SPNU151)
 - *TMS470R1x Code Generation Tools Getting Started Guide* (literature number SPNU117)
 - *TMS470R1x C Source Debugger User's Guide* (literature number SPNU124)
 - *TMS470R1x Assembly Language Tools User's Guide* (literature number SPNU118)
 - *TMS470R1x System Module Reference Guide* (literature number SPNU189)
 - *TMS470R1x Direct Memory Access (DMA) Controller Reference Guide* (literature number SPNU194)
 - *TMS470R1x Serial Peripheral Interface (SPI) Reference Guide* (literature number SPNU195)
 - *TMS470R1x Serial Communication Interface (SCI) Reference Guide* (literature number SPNU196)
 - *TMS470R1x Controller Area Network (CAN) Reference Guide* (literature number SPNU197)
 - *TMS470R1x High-End Timer (HET) Reference Guide* (literature number SPNU199)
 - *TMS470R1x External Clock Prescale (ECP) Reference Guide* (literature number SPNU202)
 - *TMS470R1x Multi-Buffered Analog-to-Digital Converter (MibADC) Reference Guide* (literature number SPNU206)
 - *TMS470R1x Zero-Pin Phase-Locked Loop (ZPLL) Clock Module Reference Guide* (literature number SPNU212)
 - *TMS470R1x F05 Flash Reference Guide* (literature number SPNU213)
 - *TMS470R1x Class II Serial Interface B (C2S1b) Reference Guide* (literature number SPNU214)
 - *TMS470R1x Expansion Bus Module (EBM) Reference Guide* (literature number SPNU222)
 - *TMS470R1x Inter-Integrated Circuit (I2C) Reference Guide* (literature number SPNU223)
- Application Reports:
 - *Analog Watchdog Resistor, Capacitor and Discharge Interval Selection Constraints* (literature number SPNA005)
 - *F05/C05 Power Up Reset and Power Sequencing Requirements* (literature number SPNA009)

TMS470R1VF689, TMS470R1VF688 16/32-BIT RISC FLASH MICROCONTROLLERS

SPNS001I – FEBRUARY 2002 – REVISED AUGUST 2005

device numbering conventions

Figure 3 illustrates the numbering and symbol nomenclature for the TMS470R1x family.

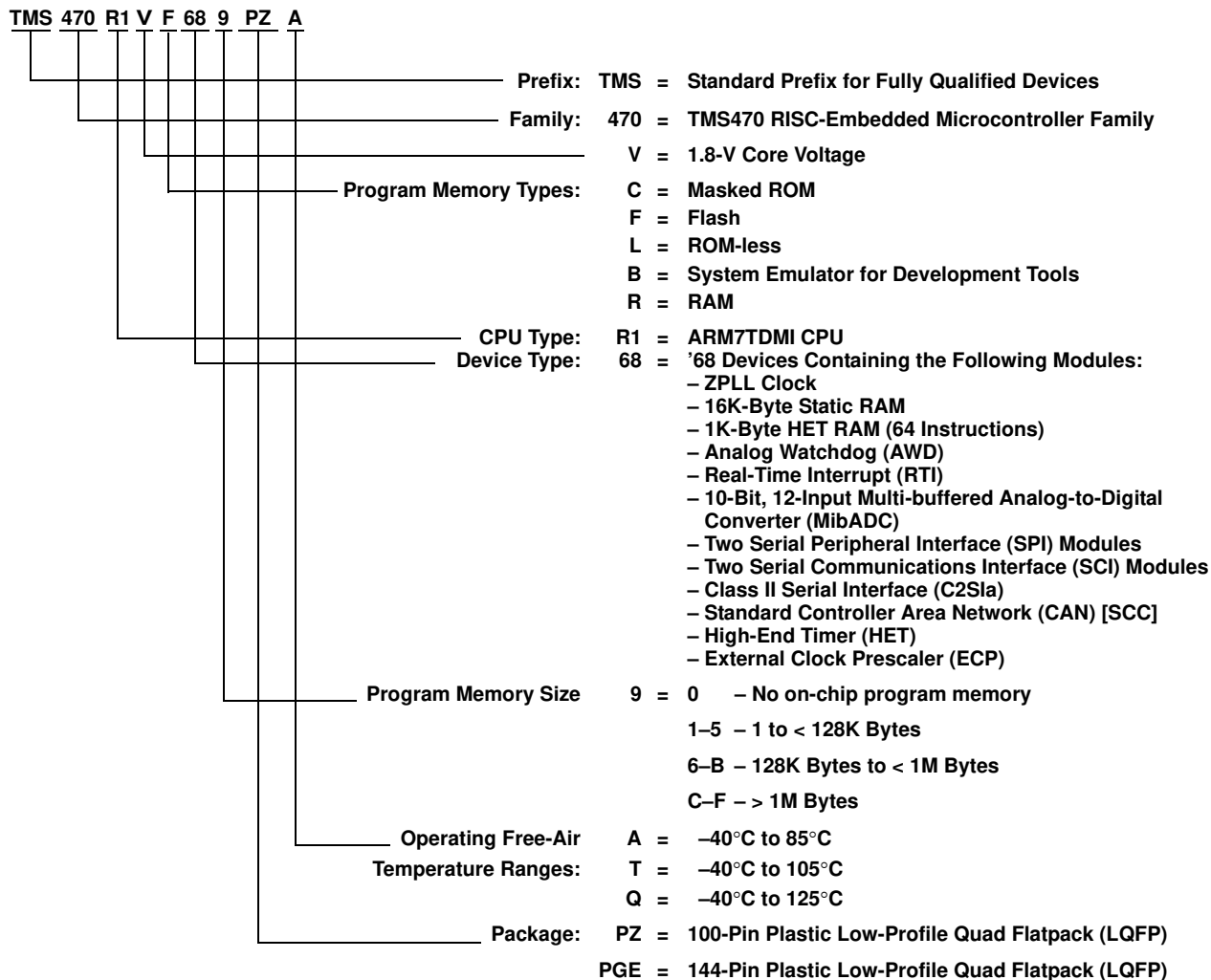

Figure 3. TMS470R1x Family Nomenclature

device identification code register

The device identification code register identifies the silicon version, the technology family (TF), a ROM or Flash device, and an assigned device-specific part number (see Table 10). The VF68x device identification code register value is 0x090F.

Table 10. TMS470 Device ID Bit Allocation Register

	BIT 31	30	29	28	27	26	25	24	23	22	21	20	19	18	17	BIT 16
FFFF_FF0	Reserved															
	BIT 15	14	13	12	11	10	9	8	7	6	5	4	3	2	1	BIT 0
	VERSION			TF	R/F	PART NUMBER						1	1	1		
	R-K			R-K	R-K	R-K						R-1	R-1	R-1		

LEGEND:

For bits 3–15: R = Read only, -K = Value constant after RESET

For bits 0–2: R = Read only, -1 = Value after RESET

- Bits 31:16** **Reserved.** Reads are undefined and writes have no effect.
- Bits 15:12** **VERSION.** Silicon version (revision) bits
These bits identify the silicon version of the device.
- Bit 11** **TF.** Technology Family (TF) bit
This bit distinguishes the technology family core power supply:
0 = 3.3 V for F10/C10 devices
1 = 1.8 V for F05/C05 devices
- Bit 10** **R/F.** ROM/Flash bit
This bit distinguishes between ROM and Flash devices:
0 = Flash device
1 = ROM device
- Bits 9:3** **PART NUMBER.** Device-specific part number bits
These bits identify the assigned device-specific part number.
The assigned device-specific part number for the VF68x device is: 0100001.
- Bits 2:0** **"1" Mandatory High.** Bits 2,1, and 0 are tied high by default.

TMS470R1VF689, TMS470R1VF688 16/32-BIT RISC FLASH MICROCONTROLLERS

SPNS001I – FEBRUARY 2002 – REVISED AUGUST 2005

device part numbers

Table 11 lists all the available TMS470R1VF689 devices.

Table 11. Device Part Number

DEVICE PART NUMBER	PROGRAM MEMORY		PACKAGE TYPE		TEMPERATURE RANGE	
	ROM	FLASH EEPROM	100-PIN LQFP	144-PIN LQFP	-40°C TO 85°C	-40°C TO 125°C
TMS470R1VF689PZA		X	X		X	
TMS470R1VF689PZAR		X	X		X	
TMS470R1VF689PGEA		X		X	X	
TMS470R1VF689PGEAR		X		X	X	
TMS470R1VF688PZA		X	X		X	
TMS470R1VF688PZAR		X	X		X	
TMS470R1VF688PGEA		X		X	X	
TMS470R1VF688PGEAR		X		X	X	

DEVICE ELECTRICAL SPECIFICATIONS AND TIMING PARAMETERS

absolute maximum ratings over operating free-air temperature range, A version (unless otherwise noted)⁽¹⁾

Supply voltage ranges: V_{CC} ⁽²⁾	–0.5 V to 2.4 V
Supply voltage ranges: V_{CCIO} , V_{CCAD} , V_{CCP} (Flash pump) ⁽²⁾	–0.5 V to 4.1 V
Input voltage range: All 5 V tolerant input pins	–0.5 V to 6.0 V
All other input pins	–0.5 V to 4.1 V
Input clamp current: All 5 V tolerant pins, \overline{PORRST} , \overline{TRST} , TEST and TCK ($V_I < 0$)	–20mA ⁽³⁾
ADIN[0:11] I_{IK} ($V_I < 0$ or $V_I > V_{CCAD}$)	±10 mA
All other pins I_{IK} ($V_I < 0$ or $V_I > V_{CCIO}$)	±20 mA
Operating free-air temperature ranges, T_A : A version	–40°C to 85°C
Q version	–40°C to 125°C
Operating junction temperature range, T_J	–40°C to 150°C
Storage temperature range, T_{stg}	–40°C to 150°C

1 Stresses beyond those listed under “absolute maximum ratings” may cause permanent damage to the device. These are stress ratings only, and functional operation of the device at these or any other conditions beyond those indicated under “recommended operating conditions” is not implied. Exposure to absolute-maximum-rated conditions for extended periods may affect device reliability.

2 All voltage values are with respect to their associated grounds.

3

device recommended operating conditions⁽³⁾

		MIN	NOM	MAX	UNIT
V_{CC} Digital logic and Flash supply voltage (Core)		1.71		2.05	V
V_{CCIO} Digital logic supply voltage (I/O)		3	3.3	3.6	V
V_{CCAD} ADC supply voltage		3	3.3	3.6	V
V_{CCP} Flash pump supply voltage		3	3.3	3.6	V
V_{SS} Digital logic supply ground			0		V
V_{SSAD} ADC supply ground		–0.1		0.1	V
T_A Operating free-air temperature	A version	–40		85	°C
	Q version	–40		125	°C
T_J Operating junction temperature		–40		150	°C

4 All voltages are with respect to V_{SS} , except V_{CCAD} , which is with respect to V_{SSAD} .

TMS470R1VF689, TMS470R1VF688

16/32-BIT RISC FLASH MICROCONTROLLERS

SPNS001I – FEBRUARY 2002 – REVISED AUGUST 2005

electrical characteristics over recommended operating free-air temperature range, A version (unless otherwise noted)⁽¹⁾

PARAMETER		TEST CONDITIONS	MIN	MAX	UNIT	
V_{hys}	Input hysteresis		0.15		V	
V_{IL}	Low-level input voltage	All inputs ⁽²⁾ except OSCIN	-0.3	0.8	V	
		OSCIN only	-0.3	0.35 V_{CC}		
V_{IH}	High-level input voltage	All inputs except OSCIN	2	$V_{CCIO} + 0.3$	V	
		OSCIN only	0.65 V_{CC}	$V_{CC} + 0.3$		
V_{th}	Input threshold voltage	AWD only	1.35	1.8	V	
RDS_{ON}	Drain to source on resistance	AWD only ⁽³⁾	$V_{OL} = 0.35V @ I_{OL} = 4mA$		Ω	
V_{OL}	Low-level output voltage ⁽⁴⁾	$I_{OL} = I_{OL} \text{ MAX}$	0.2 V_{CCIO}		V	
		$I_{OL} = 3 \text{ mA}$	0.4			
V_{OH}	High-level output voltage ⁽⁴⁾	$I_{OH} = I_{OH} \text{ MIN}$	0.8 V_{CCIO}		V	
		$I_{OH} = 250 \mu A$	2.7			
I_{IC}	Input clamp current (I/O pins) ⁽⁵⁾	$V_I < V_{SSIO} - 0.3$ or $V_I > V_{CCIO} + 0.3$	-2	2	mA	
I_I	Input current (3.3 V input pins)	I_{IL} Pulldown	$V_I = V_{SS}$	-1	1	μA
		I_{IH} Pulldown	$V_I = V_{CCIO}$	5	40	
		I_{IL} Pullup	$V_I = V_{SS}$	-40	-5	
		I_{IH} Pullup	$V_I = V_{CCIO}$	-1	1	
		All other pins	No pullup or pulldown	-1	1	
	Input current (5 V tolerant input pins)	$V_I = V_{SS}$	-1	1	μA	
		$V_I = V_{CCIO}$	-1	1		
		$V_I = 5 \text{ V}$	0.5	20		
		$V_I = 5.5 \text{ V}$	1	40		
	I_{OL}	Low-level output current	\overline{RST} , CLKOUT, AWD, TDO	$V_{OL} = V_{OL} \text{ MAX}$	4	
All other 3.3 V I/O ⁽⁶⁾			$V_{OL} = V_{OL} \text{ MAX}$	2		
5 V tolerant			$V_{OL} = V_{OL} \text{ MAX}$	4		
I_{OH}	High-level output current	\overline{RST} , CLKOUT, TDO	$V_{OH} = V_{OH} \text{ MIN}$	-4		mA
		All other 3.3 V I/O ⁽⁶⁾	$V_{OH} = V_{OH} \text{ MIN}$	-2		
		5 V tolerant	$V_{OH} = V_{OH} \text{ MIN}$	-4		

1 Source currents (out of the device) are negative while sink currents (into the device) are positive.

2 This does not apply to the PORRST pin. For PORRST exceptions, see the RST and PORRST timings section on page 41.

3 These values help to determine the external RC network circuit. For more details, see the *TMS470R1x System Module Reference Guide* (literature number SPNU189).

4 V_{OL} and V_{OH} are linear with respect to the amount of load current (I_{OL}/I_{OH}) applied.

5 Parameter does not apply to input-only or output-only pins.

6 The 2 mA buffers on this device are called zero-dominant buffers. If two of these buffers are shorted together and one is outputting a low level and the other is outputting a high level, the resulting value will always be low.

7 For Flash banks/pumps in sleep mode.

8 I/O pins configured as inputs or outputs with no load. All pulldown inputs $\leq 0.2 \text{ V}$. All pullup inputs $\geq V_{CCIO} - 0.2 \text{ V}$.



TMS470R1VF689, TMS470R1VF688 16/32-BIT RISC FLASH MICROCONTROLLERS

SPNS0011 – FEBRUARY 2002 – REVISED AUGUST 2005

electrical characteristics over recommended operating free-air temperature range, A version (unless otherwise noted)⁽¹⁾ (continued)

PARAMETER		TEST CONDITIONS	MIN	TYP	MAX	UNIT
I_{CC}	V_{CC} Digital supply current (operating mode)	SYSCLK = 24 MHz, $V_{CC} = 2.05$ V			90	mA
		SYSCLK = 48 MHz, $V_{CC} = 2.05$ V			130	mA
	V_{CC} Digital supply current (standby mode) ⁽⁷⁾	OSCIN = 4 MHz, $V_{CC} = 2.05$ V			900	μ A
	V_{CC} Digital supply current (halt mode) ⁽⁷⁾	$V_{CC} = 2.05$ V			300	μ A
I_{CCIO}	V_{CCIO} Digital supply current (operating mode)	No DC load, $V_{CCIO} = 3.6$ V ⁽⁸⁾			10	mA
	V_{CCIO} Digital supply current (standby mode)	No DC load, $V_{CCIO} = 3.6$ V ⁽⁸⁾			15	μ A
	V_{CCIO} Digital supply current (halt mode)	No DC load, $V_{CCIO} = 3.6$ V ⁽⁸⁾			10	μ A
I_{CCAD}	V_{CCAD} supply current (operating mode)	All frequencies, $V_{CCAD} = 3.6$ V			25	mA
	V_{CCAD} supply current (standby mode)	No DC load, $V_{CCAD} = 3.6$ V			10	μ A
	V_{CCAD} supply current (halt mode)	$V_{CCAD} = 3.6$ V			10	μ A
I_{CCP}	V_{CCP} pump supply current	$V_{CCP} = 3.6$ V read operation			25	mA
		$V_{CCP} = 3.6$ V program and erase			70	mA
		$V_{CCP} = 3.6$ V standby mode operation ⁽⁷⁾			10	μ A
		$V_{CCP} = 3.6$ V halt mode operation ⁽⁷⁾			10	μ A
C_I	Input capacitance			2		pF
C_O	Output capacitance			3		pF

1 Source currents (out of the device) are negative while sink currents (into the device) are positive.

2 This does not apply to the PORRST pin. For PORRST exceptions, see the RST and PORRST timings section on page 41.

3 These values help to determine the external RC network circuit. For more details, see the *TMS470R1x System Module Reference Guide* (literature number SPNU189).

4 V_{OL} and V_{OH} are linear with respect to the amount of load current (I_{OL}/I_{OH}) applied.

5 Parameter does not apply to input-only or output-only pins.

6 The 2 mA buffers on this device are called zero-dominant buffers. If two of these buffers are shorted together and one is outputting a low level and the other is outputting a high level, the resulting value will always be low.

7 For Flash banks/pumps in sleep mode.

8 I/O pins configured as inputs or outputs with no load. All pulldown inputs ≤ 0.2 V. All pullup inputs $\geq V_{CCIO} - 0.2$ V.

TMS470R1VF689, TMS470R1VF688 16/32-BIT RISC FLASH MICROCONTROLLERS

SPNS001I – FEBRUARY 2002 – REVISED AUGUST 2005

PARAMETER MEASUREMENT INFORMATION

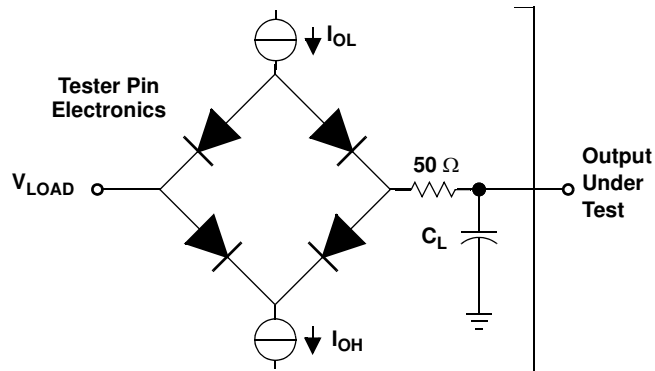

Where: I_{OL} = I_{OL} MAX for the respective pin ^(A)
 I_{OH} = I_{OH} MIN for the respective pin ^(A)
 V_{LOAD} = 1.5 V
 C_L = 150-pF typical load-circuit capacitance ^(B)

- A. For these values, see the "electrical characteristics over recommended operating free-air temperature range" table.
B. All timing parameters measured using an external load capacitance of 150 pF unless otherwise noted.

Figure 4. Test Load Circuit

timing parameter symbology

Timing parameter symbols have been created in accordance with JEDEC Standard 100. In order to shorten the symbols, some of the pin names and other related terminology have been abbreviated as follows:

CM	Compaction, CMPCT	RD	Read
CO	CLKOUT	RST	Reset, $\overline{\text{RST}}$
ER	Erase	RX	SCInRX
ICLK	Interface clock	S	Slave mode
M	Master mode	SCC	SCInCLK
OSC, OSCI	OSCIN	SIMO	SPInSIMO
OSCO	OSCOOUT	SOMI	SPInSOMI
P	Program, PROG	SPC	SPInCLK
R	Ready	SYS	System clock
R0	Read margin 0, RDMRGN0	TX	SCInTX
R1	Read margin 1, RDMRGN1		

Lowercase subscripts and their meanings are:

a	access time	r	rise time
c	cycle time (period)	su	setup time
d	delay time	t	transition time
f	fall time	v	valid time
h	hold time	w	pulse duration (width)

The following additional letters are used with these meanings:

H	High	X	Unknown, changing, or don't care level
L	Low	Z	High impedance
V	Valid		

TMS470R1VF689, TMS470R1VF688 16/32-BIT RISC FLASH MICROCONTROLLERS

SPNS001I – FEBRUARY 2002 – REVISED AUGUST 2005

external reference resonator/crystal oscillator clock option

The oscillator is enabled by connecting the appropriate fundamental 4–20 MHz resonator/crystal and load capacitors across the external OSCIN and OSCOUT pins as shown in Figure 5a. The oscillator is a single-stage inverter held in bias by an integrated bias resistor. This resistor is disabled during leakage test measurement and HALT mode. **TI strongly encourages each customer to submit samples of the device to the resonator/crystal vendors for validation.** The vendors are equipped to determine what load capacitors will best tune their resonator/crystal to the microcontroller device for optimum start-up and operation over temperature/voltage extremes.

An external oscillator source can be used by connecting a 1.8 V clock signal to the OSCIN pin and leaving the OSCOUT pin unconnected (open) as shown in Figure 5b.

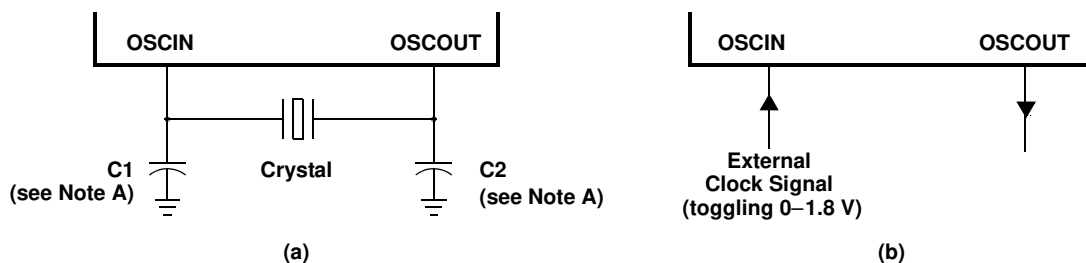

A: The values of C1 and C2 should be provided by the resonator/crystal vendor.

Figure 5. Crystal/Clock Connection

ZPLL and clock specifications

timing requirements for ZPLL circuits enabled or disabled

		MIN	TYP	MAX	UNIT
$f_{(OSC)}$	Input clock frequency	4		20	MHz
$t_{c(OSC)}$	Cycle time, OSCIN	50			ns
$t_{w(OSCIL)}$	Pulse duration, OSCIN low	15			ns
$t_{w(OSCIH)}$	Pulse duration, OSCIN high	15			ns
$f_{(OSCRST)}$	OSC FAIL frequency ⁽¹⁾		53		kHz

1 Causes a device reset (specifically a clock reset) by setting the RST OSC FAIL (GLBCTRL.15) and the OSC FAIL flag (GLBSTAT.1) bits equal to 1. For more detailed information on these bits and device resets, see the *TMS470R1x System Module Reference Guide* (literature number SPNU189).

switching characteristics over recommended operating conditions for clocks⁽²⁾⁽³⁾

PARAMETER		TEST CONDITIONS ⁽⁴⁾	MIN	MAX	UNIT
$f_{(SYS)}$	System clock frequency ⁽⁵⁾	Pipeline mode enabled		48	MHz
		Pipeline mode disabled		24	MHz
$f_{(CONFIG)}$	System clock frequency - Flash config mode			24	MHz
$f_{(ICLK)}$	Interface clock frequency			24	MHz
$f_{(ECLK)}$	External clock output frequency for ECP Module			24	MHz
$t_{c(SYS)}$	Cycle time, system clock	Pipeline mode enabled	20.8		
		Pipeline mode disabled	41.6		ns
$t_{c(CONFIG)}$	Cycle time, system clock - Flash config mode		41.6		ns
$t_{c(ICLK)}$	Cycle time, interface clock		41.6		ns
$t_{c(ECLK)}$	Cycle time, ECP module external clock output		41.6		ns

2 $f_{(SYS)} = M \times f_{(OSC)} / R$, where $M = \{4 \text{ or } 8\}$, $R = \{1, 2, 3, 4, 5, 6, 7, 8\}$ when $PLLDIS = 0$. R is the system-clock divider determined by the CLKDIVPRE [2:0] bits in the global control register (GLBCTRL.[2:0]) and M is the PLL multiplier determined by the MULT4 bit also in the GLBCTRL register (GLBCTRL.3).

$f_{(SYS)} = f_{(OSC)} / R$, where $R = \{1, 2, 3, 4, 5, 6, 7, 8\}$ when $PLLDIS = 1$.

$f_{(ICLK)} = f_{(SYS)} / X$, where $X = \{1, 2, 3, 4, 5, 6, 7, 8, 9, 10, 11, 12, 13, 14, 15, 16\}$. X is the interface clock divider ratio determined by the PCR0.[4:1] bits in the SYS module.

3 $f_{(ECLK)} = f_{(ICLK)} / N$, where $N = \{1 \text{ to } 256\}$. N is the ECP prescale value defined by the ECPCTRL.[7:0] register bits in the ECP module.

4 Pipeline mode enabled or disabled is determined by the ENPIPE bit (FMREGOPT.0).

5 Flash Vread must be set to 5V to achieve maximum System Clock Frequency.

TMS470R1VF689, TMS470R1VF688 16/32-BIT RISC FLASH MICROCONTROLLERS

SPNS001I – FEBRUARY 2002 – REVISED AUGUST 2005

ZPLL and clock specifications (continued)

switching characteristics over recommended operating conditions for external clocks
(see Figure 6 and Figure 7)⁽¹⁾⁽²⁾⁽³⁾

NO.	PARAMETER	TEST CONDITIONS	MIN	MAX	UNIT
1	$t_{w(COL)}$ Pulse duration, CLKOUT low	SYSCLK or MCLK ⁽⁴⁾	$0.5t_{c(SYS)} - t_f$		ns
		ICLK, X is even or 1 ⁽⁵⁾	$0.5t_{c(ICLK)} - t_f$		
		ICLK, X is odd and not 1 ⁽⁵⁾	$0.5t_{c(ICLK)} + 0.5t_{c(SYS)} - t_f$		
2	$t_{w(COH)}$ Pulse duration, CLKOUT high	SYSCLK or MCLK ⁽⁴⁾	$0.5t_{c(SYS)} - t_r$		ns
		ICLK, X is even or 1 ⁽⁵⁾	$0.5t_{c(ICLK)} - t_r$		
		ICLK, X is odd and not 1 ⁽⁵⁾	$0.5t_{c(ICLK)} - 0.5t_{c(SYS)} - t_r$		
3	$t_{w(EOL)}$ Pulse duration, ECLK low	N is even and X is even or odd	$0.5t_{c(ECLK)} - t_f$		ns
		N is odd and X is even	$0.5t_{c(ECLK)} - t_f$		
		N is odd and X is odd and not 1	$0.5t_{c(ECLK)} + 0.5t_{c(SYS)} - t_f$		
4	$t_{w(EOH)}$ Pulse duration, ECLK high	N is even and X is even or odd	$0.5t_{c(ECLK)} - t_r$		ns
		N is odd and X is even	$0.5t_{c(ECLK)} - t_r$		
		N is odd and X is odd and not 1	$0.5t_{c(ECLK)} - 0.5t_{c(SYS)} - t_r$		

1 X = {1,2,3,4,5,6,7,8,9,10,11,12,13,14,15,16}. X is the interface clock divider ratio determined by the PCR0.[4:1] bits in the SYS module.

2 N = {1 to 256}. N is the ECP prescale value defined by the ECPCTRL.[7:0] register bits in the ECP module.

3 CLKOUT/ECLK pulse durations (low/high) are a function of the OSCIN pulse durations when PLLDIS is active.

4 Clock source bits selected as either SYSCLK (CLKCNTL.[6:5] = 11 binary) or MCLK (CLKCNTL.[6:5] = 10 binary).

5 Clock source bits selected as ICLK (CLKCNTL.[6:5] = 01 binary).

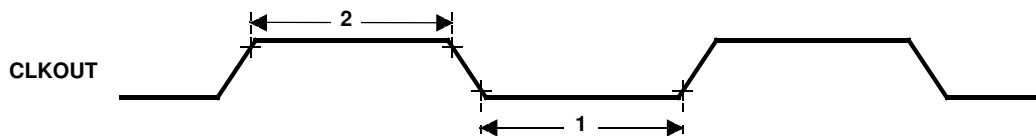

Figure 6. CLKOUT Timing Diagram

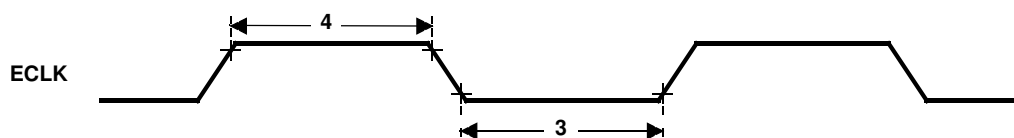

Figure 7. ECLK Timing Diagram

RST and PORRST timings

timing requirements for PORRST (see Figure 8)

NO.		MIN	MAX	UNIT
	V_{CCPORL}		0.6	V
	V_{CCPORH}	1.5		V
	$V_{CCIOPORL}$		1.1	V
	$V_{CCIOPORH}$		2.75	V
	V_{IL}		$0.2 V_{CCIO}$	V
	$V_{IL(PORRST)}$		0.5	V
3	$t_{su(PORRST)r}$	0		ms
5	$t_{su(VCCIO)r}$	0		ms
6	$t_h(PORRST)r$	1		ms
7	$t_{su(PORRST)f}$	8		μs
8	$t_h(PORRST)rio$	1		ms
9	$t_h(PORRST)d$	0		ms
10	$t_{su(PORRST)fo}$	0		ns
11	$t_{su(VCCIO)f}$	0		ns

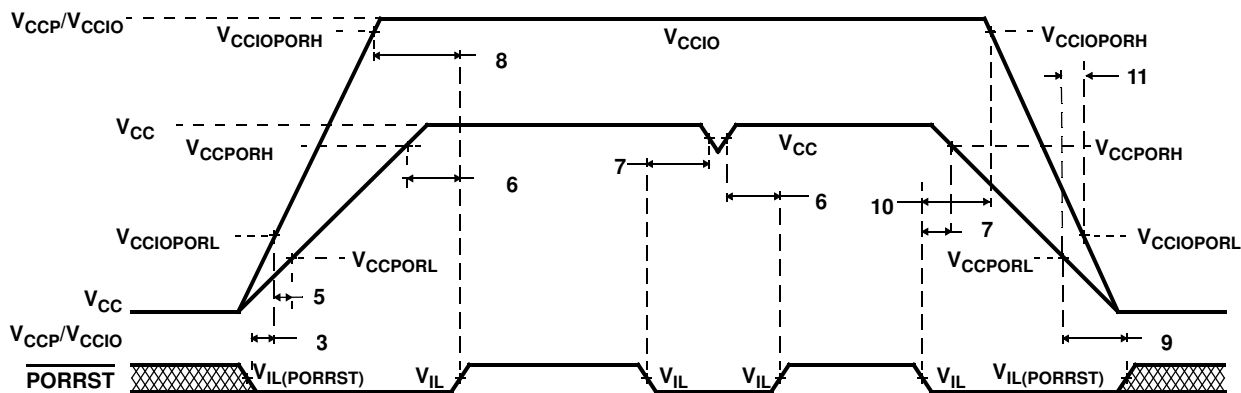

Figure 8. PORRST Timing Diagram

switching characteristics over recommended operating conditions for RST⁽¹⁾

PARAMETER		MIN	MAX	UNIT
$t_{v(RST)}$	Valid time, RST active after PORRST inactive	$4112t_{c(OSC)}$		ns
	Valid time, RST active (all others)	$8t_{c(SYS)}$		
t_{fsu}	Flash start up time, from RST inactive to fetch of first instruction from flash (flash pump stabilization time)	$360t_{c(OSC)}$		ns

1 Specified values do NOT include rise/fall times. For rise and fall timings, see the "switching characteristics for output timings versus load capacitance" table.

TMS470R1VF689, TMS470R1VF688

16/32-BIT RISC FLASH MICROCONTROLLERS

SPNS001I – FEBRUARY 2002 – REVISED AUGUST 2005

JTAG scan interface timing (JTAG clock specification 10-MHz and 50-pF load on TDO output)

NO.		MIN	MAX	UNIT
1	$t_{c(JTAG)}$ Cycle time, JTAG low and high period	50		ns
2	$t_{su(TDI/TMS - TCKr)}$ Setup time, TDI, TMS before TCK rise (TCKr)	15		ns
3	$t_h(TCKr - TDI/TMS)$ Hold time, TDI, TMS after TCKr	15		ns
4	$t_h(TCKf - TDO)$ Hold time, TDO after TCKf	10		ns
5	$t_d(TCKf - TDO)$ Delay time, TDO valid after TCK fall (TCKf)		45	ns

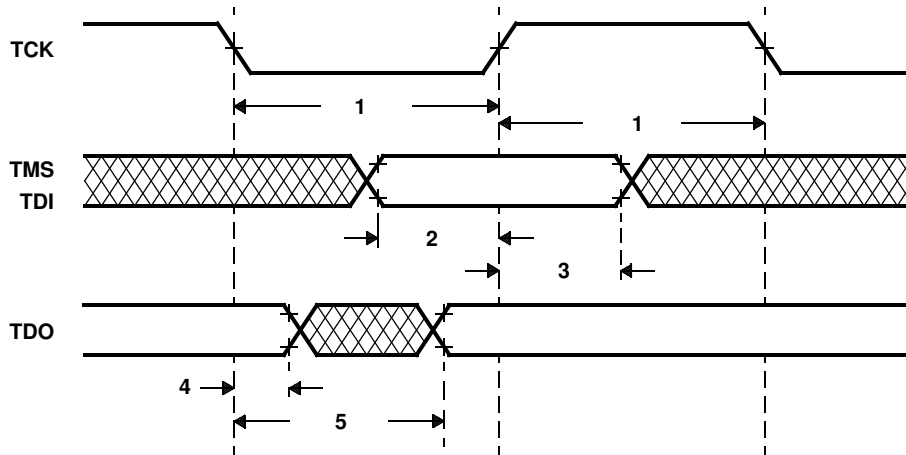

TMS470R1VF689, TMS470R1VF688 16/32-BIT RISC FLASH MICROCONTROLLERS

SPNS0011 – FEBRUARY 2002 – REVISED AUGUST 2005

output timings

switching characteristics for output timings versus load capacitance (C_L) (see Figure 9)

PARAMETER		MIN	MAX	UNIT	
t_r	Rise time, AWD, CLKOUT, \overline{RST} , TDO/GIOC[6]	$C_L = 15 \text{ pF}$	2.5	8	ns
		$C_L = 50 \text{ pF}$	5	14	
		$C_L = 100 \text{ pF}$	9	23	
		$C_L = 150 \text{ pF}$	13	32	
t_f	Fall time, AWD, CLKOUT, TDO/GIOC[6]	$C_L = 15 \text{ pF}$	2.5	8	ns
		$C_L = 50 \text{ pF}$	5	14	
		$C_L = 100 \text{ pF}$	9	23	
		$C_L = 150 \text{ pF}$	13	32	
t_r	Rise time, 4mA, 5 V tolerant pins	$C_L = 15 \text{ pF}$	3	10	ns
		$C_L = 50 \text{ pF}$	3.5	12	
		$C_L = 100 \text{ pF}$	7	21	
		$C_L = 150 \text{ pF}$	9	28	
t_f	Fall time, 4mA, 5 V tolerant pins	$C_L = 15 \text{ pF}$	2	8	ns
		$C_L = 50 \text{ pF}$	2.5	9	
		$C_L = 100 \text{ pF}$	8	25	
		$C_L = 150 \text{ pF}$	11	35	
t_r	Rise time, all other output pins	$C_L = 15 \text{ pF}$	2.5	10	ns
		$C_L = 50 \text{ pF}$	6.0	25	
		$C_L = 100 \text{ pF}$	12	45	
		$C_L = 150 \text{ pF}$	18	65	
t_f	Fall time, all other output pins	$C_L = 15 \text{ pF}$	3	10	ns
		$C_L = 50 \text{ pF}$	8.5	25	
		$C_L = 100 \text{ pF}$	16	45	
		$C_L = 150 \text{ pF}$	23	65	

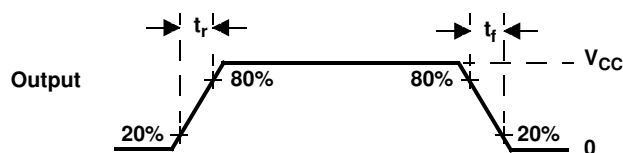

Figure 9. CMOS-Level Outputs

TMS470R1VF689, TMS470R1VF688 16/32-BIT RISC FLASH MICROCONTROLLERS

SPNS001I – FEBRUARY 2002 – REVISED AUGUST 2005

input timings

timing requirements for input timings⁽¹⁾ (see Figure 10)

	MIN	MAX	UNIT
t_{pw} Input minimum pulse width	$t_{c(ICLK)} + 10$		ns

¹ $t_{c(ICLK)}$ = interface clock cycle time = $1/f_{(ICLK)}$

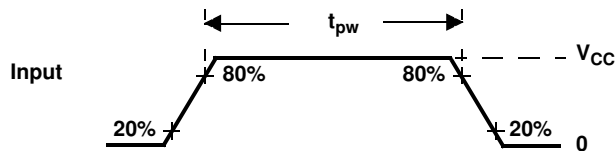

Figure 10. CMOS-Level Inputs

TMS470R1VF689, TMS470R1VF688 16/32-BIT RISC FLASH MICROCONTROLLERS

SPNS0011 – FEBRUARY 2002 – REVISED AUGUST 2005

Flash timings

timing requirements for program Flash⁽¹⁾

		MIN	TYP	MAX	UNIT
$t_{\text{prog(16-bit)}}$	Half word (16-bit) programming time	4	16	200	μs
$t_{\text{prog(Total)}}$	384K-byte programming time (VF689 only) ⁽²⁾		3	10	s
$t_{\text{prog(Total)}}$	256K-byte programming time (VF688 only) ⁽²⁾		2	8	s
$t_{\text{erase(sector)}}$	Sector erase time		2	15	s
t_{wec}	Write/erase cycles at $T_A = 125^\circ\text{C}$	1000	10000		cycles
$t_{\text{p}(\overline{\text{RST}})}$	Flash pump settling time from $\overline{\text{RST}}$ to SLEEP		$72t_{\text{c(SYS)}}$		ns
$t_{\text{p(SLEEP)}}$	Initial flash pump settling time from SLEEP to STANDBY		$72t_{\text{c(SYS)}}$		ns
$t_{\text{p(STDBY)}}$	Initial flash pump settling time from STANDBY to ACTIVE		$36t_{\text{c(SYS)}}$		ns

1 For more detailed information on the Flash core sectors, see the Flash program and erase section of this data sheet.

2 The 384K-byte and 256K-byte programming times include overhead of state machine.

TMS470R1VF689, TMS470R1VF688 16/32-BIT RISC FLASH MICROCONTROLLERS

SPNS001I – FEBRUARY 2002 – REVISED AUGUST 2005

SPI master mode timing parameters

SPI master mode external timing parameters (CLOCK PHASE = 0, SPInCLK = output, SPInSIMO = output, and SPInSOMI = input)⁽¹⁾⁽²⁾⁽³⁾ (see Figure 11)

NO.		MIN	MAX	UNIT
1	$t_{c(SPC)M}$ Cycle time, SPInCLK ⁽⁴⁾	100	$256t_{c(ICLK)}$	ns
2 ⁽⁵⁾	$t_{w(SPCH)M}$ Pulse duration, SPInCLK high (clock polarity = 0)	$0.5t_{c(SPC)M} - t_r$	$0.5t_{c(SPC)M} + 5$	
	$t_{w(SPCL)M}$ Pulse duration, SPInCLK low (clock polarity = 1)	$0.5t_{c(SPC)M} - t_f$	$0.5t_{c(SPC)M} + 5$	
3 ⁽⁵⁾	$t_{w(SPCL)M}$ Pulse duration, SPInCLK low (clock polarity = 0)	$0.5t_{c(SPC)M} - t_f$	$0.5t_{c(SPC)M} + 5$	
	$t_{w(SPCH)M}$ Pulse duration, SPInCLK high (clock polarity = 1)	$0.5t_{c(SPC)M} - t_r$	$0.5t_{c(SPC)M} + 5$	
4 ⁽⁵⁾	$t_{d(SPCH-SIMO)M}$ Delay time, SPInCLK high to SPInSIMO valid (clock polarity = 0)		10	
	$t_{d(SPCL-SIMO)M}$ Delay time, SPInCLK low to SPInSIMO valid (clock polarity = 1)		10	
5 ⁽⁵⁾	$t_{v(SPCL-SIMO)M}$ Valid time, SPInSIMO data valid after SPInCLK low (clock polarity = 0)	$t_{c(SPC)M} - 5 - t_f$		
	$t_{v(SPCH-SIMO)M}$ Valid time, SPInSIMO data valid after SPInCLK high (clock polarity = 1)	$t_{c(SPC)M} - 5 - t_r$		
6 ⁽⁵⁾	$t_{su(SOMI-SPCL)M}$ Setup time, SPInSOMI before SPInCLK low (clock polarity = 0)	6		
	$t_{su(SOMI-SPCH)M}$ Setup time, SPInSOMI before SPInCLK high (clock polarity = 1)	6		
7 ⁽⁵⁾	$t_{v(SPCL-SOMI)M}$ Valid time, SPInSOMI data valid after SPInCLK low (clock polarity = 0)	4		
	$t_{v(SPCH-SOMI)M}$ Valid time, SPInSOMI data valid after SPInCLK high (clock polarity = 1)	4		

1 The MASTER bit (SPInCTRL2.3) is set and the CLOCK PHASE bit (SPInCTRL2.0) is cleared.

2 $t_{c(ICLK)}$ = interface clock cycle time = $1/f_{(ICLK)}$

3 For rise and fall timings, see the "switching characteristics for output timings versus load capacitance" table.

4 When the SPI is in Master mode, the following must be true:

For PS values from 1 to 255: $t_{c(SPC)M} \geq (PS + 1)t_{c(ICLK)} \geq 100$ ns, where PS is the prescale value set in the SPInCTL1.[12:5] register bits.

For PS values of 0: $t_{c(SPC)M} = 2t_{c(ICLK)} \geq 100$ ns.

5 The active edge of the SPInCLK signal referenced is controlled by the CLOCK POLARITY bit (SPInCTRL2.1).

SPI master mode timing parameters (continued)

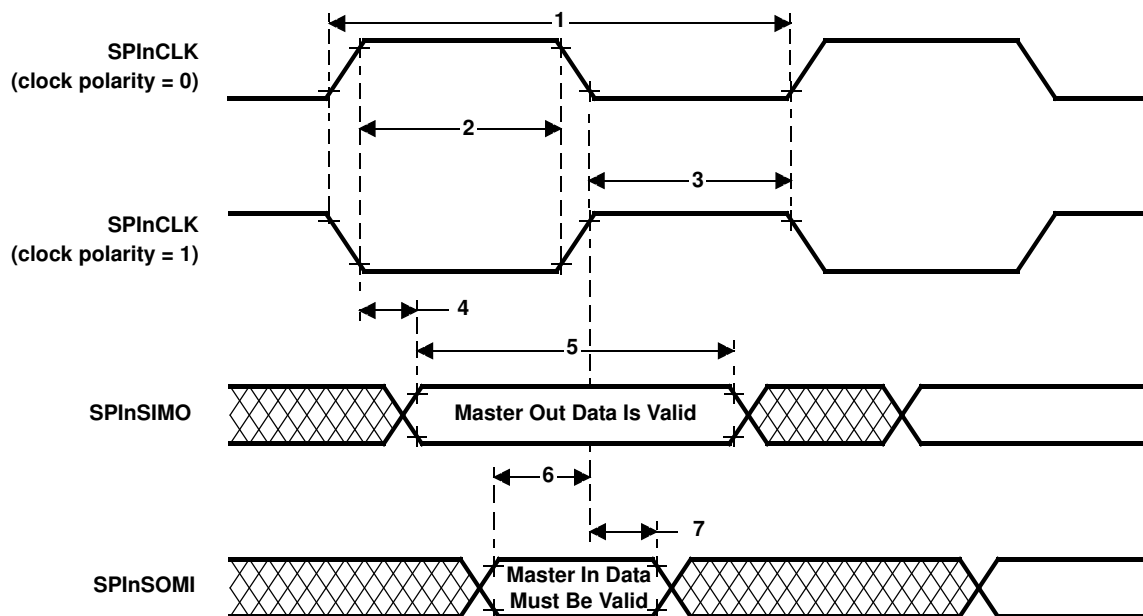

Figure 11. SPIn Master Mode External Timing (CLOCK PHASE = 0)

TMS470R1VF689, TMS470R1VF688

16/32-BIT RISC FLASH MICROCONTROLLERS

SPNS001I – FEBRUARY 2002 – REVISED AUGUST 2005

SPIn master mode timing parameters (continued)

SPIn master mode external timing parameters (CLOCK PHASE = 1, SPInCLK = output, SPInSIMO = output, and SPInSOMI = input)⁽¹⁾⁽²⁾⁽³⁾ (see Figure 12)

NO.		MIN	MAX	UNIT
1	$t_{c(SPC)M}$ Cycle time, SPInCLK ⁽⁴⁾	100	$256t_{c(ICLK)}$	ns
2 ⁽⁵⁾	$t_{w(SPCH)M}$ Pulse duration, SPInCLK high (clock polarity = 0)	$0.5t_{c(SPC)M} - t_r$	$0.5t_{c(SPC)M} + 5$	
	$t_{w(SPCL)M}$ Pulse duration, SPInCLK low (clock polarity = 1)	$0.5t_{c(SPC)M} - t_f$	$0.5t_{c(SPC)M} + 5$	
3 ⁽⁵⁾	$t_{w(SPCL)M}$ Pulse duration, SPInCLK low (clock polarity = 0)	$0.5t_{c(SPC)M} - t_f$	$0.5t_{c(SPC)M} + 5$	
	$t_{w(SPCH)M}$ Pulse duration, SPInCLK high (clock polarity = 1)	$0.5t_{c(SPC)M} - t_r$	$0.5t_{c(SPC)M} + 5$	
4 ⁽⁵⁾	$t_{v(SIMO-SPCH)M}$ Valid time, SPInCLK high after SPInSIMO data valid (clock polarity = 0)	$0.5t_{c(SPC)M} - 10$		
	$t_{v(SIMO-SPCL)M}$ Valid time, SPInCLK low after SPInSIMO data valid (clock polarity = 1)	$0.5t_{c(SPC)M} - 10$		
5 ⁽⁵⁾	$t_{v(SPCH-SIMO)M}$ Valid time, SPInSIMO data valid after SPInCLK high (clock polarity = 0)	$0.5t_{c(SPC)M} - 5 - t_r$		
	$t_{v(SPCL-SIMO)M}$ Valid time, SPInSIMO data valid after SPInCLK low (clock polarity = 1)	$0.5t_{c(SPC)M} - 5 - t_f$		
6 ⁽⁵⁾	$t_{su(SOMI-SPCH)M}$ Setup time, SPInSOMI before SPInCLK high (clock polarity = 0)	6		
	$t_{su(SOMI-SPCL)M}$ Setup time, SPInSOMI before SPInCLK low (clock polarity = 1)	6		
7 ⁽⁵⁾	$t_{v(SPCH-SOMI)M}$ Valid time, SPInSOMI data valid after SPInCLK high (clock polarity = 0)	6		
	$t_{v(SPCL-SOMI)M}$ Valid time, SPInSOMI data valid after SPInCLK low (clock polarity = 1)	6		

1 The MASTER bit (SPInCTRL2.3) is set and the CLOCK PHASE bit (SPInCTRL2.0) is set.

2 $t_{c(ICLK)}$ = interface clock cycle time = $1/f_{(ICLK)}$

3 For rise and fall timings, see the "switching characteristics for output timings versus load capacitance" table.

4 When the SPI is in Master mode, the following must be true:

For PS values from 1 to 255: $t_{c(SPC)M} \geq (PS + 1)t_{c(ICLK)} \geq 100$ ns, where PS is the prescale value set in the SPInCTL1.[12:5] register bits.

For PS values of 0: $t_{c(SPC)M} = 2t_{c(ICLK)} \geq 100$ ns.

5 The active edge of the SPInCLK signal referenced is controlled by the CLOCK POLARITY bit (SPInCTRL2.1).

SPIn master mode timing parameters (continued)

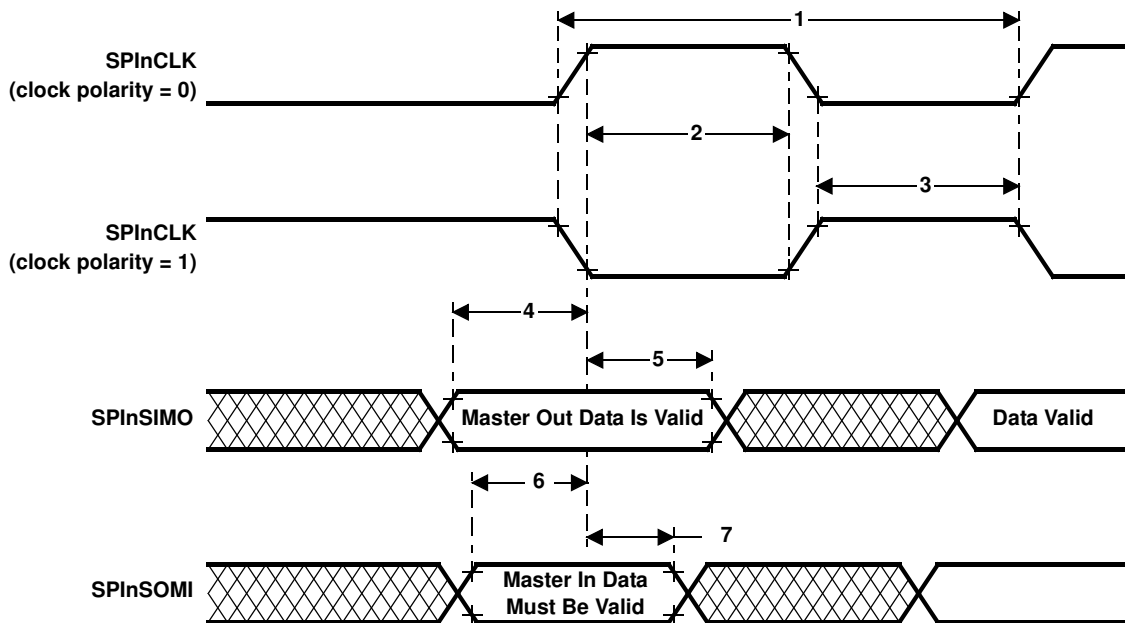

Figure 12. SPIn Master Mode External Timing (CLOCK PHASE = 1)

TMS470R1VF689, TMS470R1VF688

16/32-BIT RISC FLASH MICROCONTROLLERS

SPNS001I – FEBRUARY 2002 – REVISED AUGUST 2005

SPIn slave mode timing parameters

SPIn slave mode external timing parameters (CLOCK PHASE = 0, SPInCLK = input, SPInSIMO = input, and SPInSOMI = output)⁽¹⁾⁽²⁾⁽³⁾⁽⁴⁾ (see Figure 13)

NO		MIN	MAX	UNIT
1	$t_{c(SPC)S}$ Cycle time, SPInCLK ⁽⁵⁾	100	$256t_{c(ICLK)}$	ns
2 ⁽⁶⁾	$t_{w(SPCH)S}$ Pulse duration, SPInCLK high (clock polarity = 0)	$0.5t_{c(SPC)S} - 0.25t_{c(ICLK)}$	$0.5t_{c(SPC)S} + 0.25t_{c(ICLK)}$	
	$t_{w(SPCL)S}$ Pulse duration, SPInCLK low (clock polarity = 1)	$0.5t_{c(SPC)S} - 0.25t_{c(ICLK)}$	$0.5t_{c(SPC)S} + 0.25t_{c(ICLK)}$	
3 ⁽⁶⁾	$t_{w(SPCL)S}$ Pulse duration, SPInCLK low (clock polarity = 0)	$0.5t_{c(SPC)S} - 0.25t_{c(ICLK)}$	$0.5t_{c(SPC)S} + 0.25t_{c(ICLK)}$	
	$t_{w(SPCH)S}$ Pulse duration, SPInCLK high (clock polarity = 1)	$0.5t_{c(SPC)S} - 0.25t_{c(ICLK)}$	$0.5t_{c(SPC)S} + 0.25t_{c(ICLK)}$	
4 ⁽⁶⁾	$t_{d(SPCH-SOMI)S}$ Delay time, SPInCLK high to SPInSOMI valid (clock polarity = 0)		$6 + t_r$	
	$t_{d(SPCL-SOMI)S}$ Delay time, SPInCLK low to SPInSOMI valid (clock polarity = 1)		$6 + t_f$	
5 ⁽⁶⁾	$t_{v(SPCH-SOMI)S}$ Valid time, SPInSOMI data valid after SPInCLK high (clock polarity = 0)	$t_{c(SPC)S} - 6 - t_r$		
	$t_{v(SPCL-SOMI)S}$ Valid time, SPInSOMI data valid after SPInCLK low (clock polarity = 1)	$t_{c(SPC)S} - 6 - t_f$		
6 ⁽⁶⁾	$t_{su(SIMO-SPCL)S}$ Setup time, SPInSIMO before SPInCLK low (clock polarity = 0)	6		
	$t_{su(SIMO-SPCH)S}$ Setup time, SPInSIMO before SPInCLK high (clock polarity = 1)	6		
7 ⁽⁶⁾	$t_{v(SPCL-SIMO)S}$ Valid time, SPInSIMO data valid after SPInCLK low (clock polarity = 0)	6		
	$t_{v(SPCH-SIMO)S}$ Valid time, SPInSIMO data valid after SPInCLK high (clock polarity = 1)	6		

1 The MASTER bit (SPInCTRL2.3) is cleared and the CLOCK PHASE bit (SPInCTRL2.0) is cleared.

2 If the SPI is in slave mode, the following must be true: $t_{c(SPC)S} \geq (PS + 1) t_{c(ICLK)}$, where PS = prescale value set in SPInCTL1.[12:5].

3 For rise and fall timings, see the "switching characteristics for output timings versus load capacitance" table.

4 $t_{c(ICLK)}$ = interface clock cycle time = $1/f_{(ICLK)}$

5 When the SPIn is in Slave mode, the following must be true:

For PS values from 1 to 255: $t_{c(SPC)S} \geq (PS + 1)t_{c(ICLK)} \geq 100$ ns, where PS is the prescale value set in the SPInCTL1.[12:5] register bits.

For PS values of 0: $t_{c(SPC)S} = 2t_{c(ICLK)} \geq 100$ ns.

6 The active edge of the SPInCLK signal referenced is controlled by the CLOCK POLARITY bit (SPInCTRL2.1).

SPI slave mode timing parameters (continued)

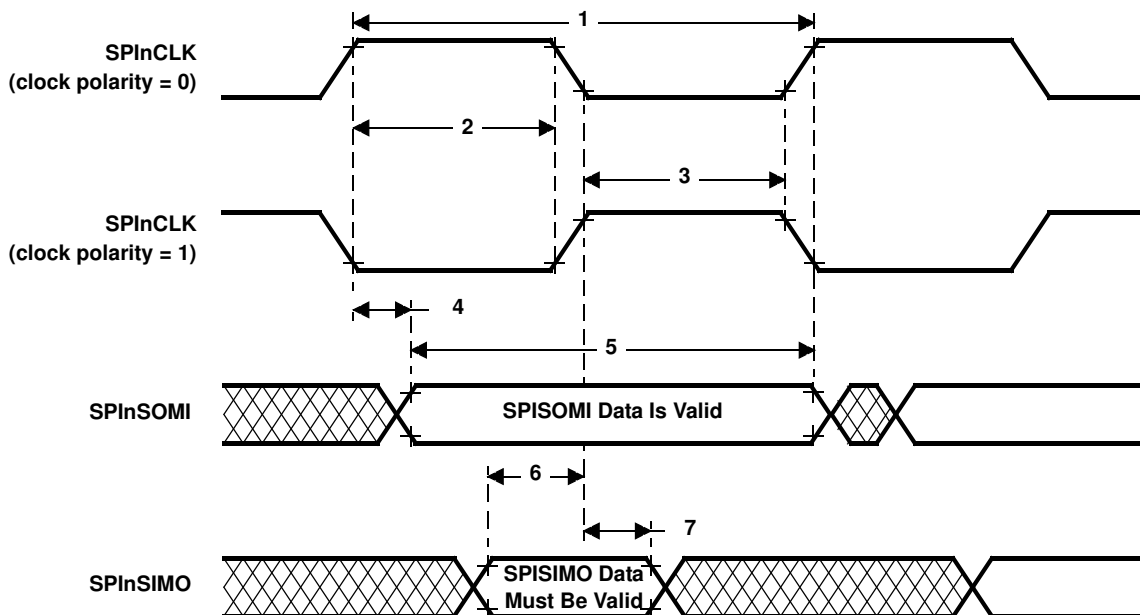

Figure 13. SPI Slave Mode External Timing (CLOCK PHASE = 0)

TMS470R1VF689, TMS470R1VF688

16/32-BIT RISC FLASH MICROCONTROLLERS

SPNS001I – FEBRUARY 2002 – REVISED AUGUST 2005

SPIn slave mode timing parameters (continued)

SPIn slave mode external timing parameters (CLOCK PHASE = 1, SPInCLK = input, SPInSIMO = input, and SPInSOMI = output)⁽¹⁾⁽²⁾⁽³⁾⁽⁴⁾ (see Figure 14)

NO		MIN	MAX	UNIT
1	$t_{c(SPC)S}$ Cycle time, SPInCLK ⁽⁵⁾	100	$256t_{c(ICLK)}$	ns
2 ⁽⁶⁾	$t_{w(SPCH)S}$ Pulse duration, SPInCLK high (clock polarity = 0)	$0.5t_{c(SPC)S} - 0.25t_{c(ICLK)}$	$0.5t_{c(SPC)S} + 0.25t_{c(ICLK)}$	
	$t_{w(SPCL)S}$ Pulse duration, SPInCLK low (clock polarity = 1)	$0.5t_{c(SPC)S} - 0.25t_{c(ICLK)}$	$0.5t_{c(SPC)S} + 0.25t_{c(ICLK)}$	
3 ⁽⁶⁾	$t_{w(SPCL)S}$ Pulse duration, SPInCLK low (clock polarity = 0)	$0.5t_{c(SPC)S} - 0.25t_{c(ICLK)}$	$0.5t_{c(SPC)S} + 0.25t_{c(ICLK)}$	
	$t_{w(SPCH)S}$ Pulse duration, SPInCLK high (clock polarity = 1)	$0.5t_{c(SPC)S} - 0.25t_{c(ICLK)}$	$0.5t_{c(SPC)S} + 0.25t_{c(ICLK)}$	
4 ⁽⁶⁾	$t_{v(SOMI-SPCH)S}$ Valid time, SPInCLK high after SPInSOMI data valid (clock polarity = 0)	$0.5t_{c(SPC)S} - 6 - t_r$		
	$t_{v(SOMI-SPCL)S}$ Valid time, SPInCLK low after SPInSOMI data valid (clock polarity = 1)	$0.5t_{c(SPC)S} - 6 - t_f$		
5 ⁽⁶⁾	$t_{v(SPCH-SOMI)S}$ Valid time, SPInSOMI data valid after SPInCLK high (clock polarity = 0)	$0.5t_{c(SPC)S} - 6 - t_r$		
	$t_{v(SPCL-SOMI)S}$ Valid time, SPInSOMI data valid after SPInCLK low (clock polarity = 1)	$0.5t_{c(SPC)S} - 6 - t_f$		
6 ⁽⁶⁾	$t_{su(SIMO-SPCH)S}$ Setup time, SPInSIMO before SPInCLK high (clock polarity = 0)	6		
	$t_{su(SIMO-SPCL)S}$ Setup time, SPInSIMO before SPInCLK low (clock polarity = 1)	6		
7 ⁽⁶⁾	$t_{v(SPCH-SIMO)S}$ Valid time, SPInSIMO data valid after SPInCLK high (clock polarity = 0)	6		
	$t_{v(SPCL-SIMO)S}$ Valid time, SPInSIMO data valid after SPInCLK low (clock polarity = 1)	6		

1 The MASTER bit (SPInCTRL2.3) is cleared and the CLOCK PHASE bit (SPInCTRL2.0) is set.

2 If the SPI is in slave mode, the following must be true: $t_{c(SPC)S} \geq (PS + 1)t_{c(ICLK)}$, where PS = prescale value set in SPInCTL1.[12:5].

3 For rise and fall timings, see the "switching characteristics for output timings versus load capacitance" table.

4 $t_{c(ICLK)}$ = interface clock cycle time = $1/f_{(ICLK)}$

5 When the SPIn is in Slave mode, the following must be true:

For PS values from 1 to 255: $t_{c(SPC)S} \geq (PS + 1)t_{c(ICLK)} \geq 100$ ns, where PS is the prescale value set in the SPInCTL1.[12:5] register bits.

For PS values of 0: $t_{c(SPC)S} = 2t_{c(ICLK)} \geq 100$ ns.

6 The active edge of the SPInCLK signal referenced is controlled by the CLOCK POLARITY bit (SPInCTRL2.1).

SPIn slave mode timing parameters (continued)

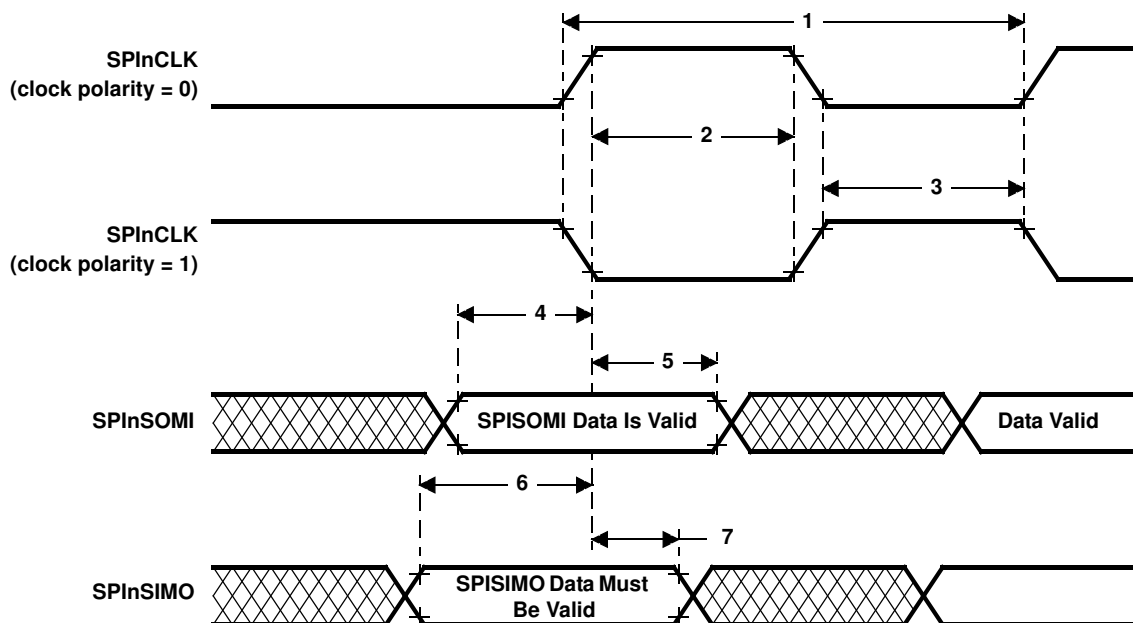

Figure 14. SPIn Slave Mode External Timing (CLOCK PHASE = 1)

TMS470R1VF689, TMS470R1VF688 16/32-BIT RISC FLASH MICROCONTROLLERS

SPNS001I – FEBRUARY 2002 – REVISED AUGUST 2005

SCIn isosynchronous mode timings — internal clock

timing requirements for internal clock SCIn isosynchronous mode⁽¹⁾⁽²⁾⁽³⁾ (see Figure 15)

NO.		(BAUD + 1) IS EVEN OR BAUD = 0		(BAUD + 1) IS ODD AND BAUD ≠ 0		UNIT
		MIN	MAX	MIN	MAX	
1	$t_{c(SCC)}$ Cycle time, SCInCLK	$2t_{c(ICKL)}$	$2^{24}t_{c(ICKL)}$	$3t_{c(ICKL)}$	$(2^{24} - 1)t_{c(ICKL)}$	ns
2	$t_{w(SCCL)}$ Pulse duration, SCInCLK low	$0.5t_{c(SCC)} - t_f$	$0.5t_{c(SCC)} + 5$	$0.5t_{c(SCC)} + 0.5t_{c(ICKL)} - t_f$	$0.5t_{c(SCC)} + 0.5t_{c(ICKL)}$	ns
3	$t_{w(SCCH)}$ Pulse duration, SCInCLK high	$0.5t_{c(SCC)} - t_f$	$0.5t_{c(SCC)} + 5$	$0.5t_{c(SCC)} - 0.5t_{c(ICKL)} - t_f$	$0.5t_{c(SCC)} - 0.5t_{c(ICKL)}$	ns
4	$t_d(SCCH-TXV)$ Delay time, SCInCLK high to SCInTX valid		10		10	ns
5	$t_v(TX)$ Valid time, SCInTX data after SCInCLK low	$t_{c(SCC)} - 10$		$t_{c(SCC)} - 10$		ns
6	$t_{su(RX-SCCL)}$ Setup time, SCInRX before SCInCLK low	$t_{c(ICKL)} + t_f + 20$		$t_{c(ICKL)} + t_f + 20$		ns
7	$t_v(SCCL-RX)$ Valid time, SCInRX data after SCInCLK low	$-t_{c(ICKL)} + t_f + 20$		$-t_{c(ICKL)} + t_f + 20$		ns

1 BAUD = 24-bit concatenated value formed by the SCI[H,M,L]BAUD registers.

2 $t_{c(ICKL)}$ = interface clock cycle time = $1/f_{(ICKL)}$

3 For rise and fall timings, see the switching characteristics for output timings versus load capacitance table.

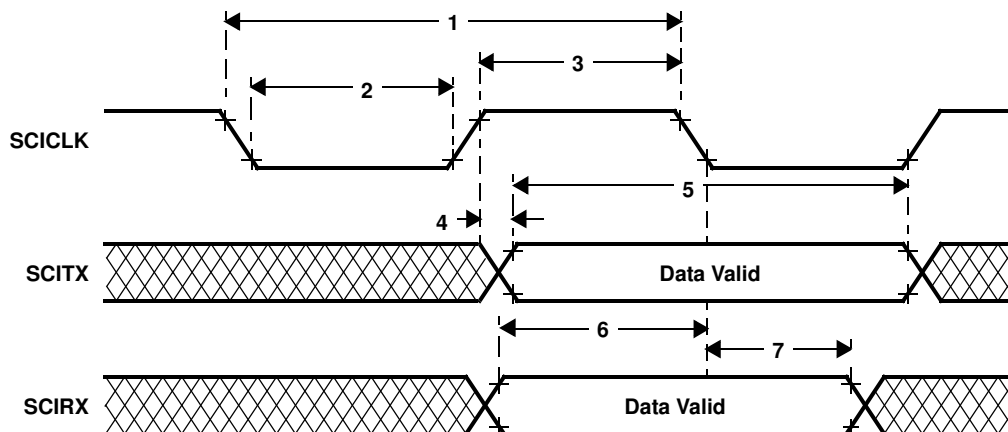

NOTE A: Data transmission/reception characteristics for isosynchronous mode with internal clocking are similar to the asynchronous mode. Data transmission occurs on the SCICLK rising edge, and data reception on the SCICLK falling edge.

Figure 15. SCIn Isosynchronous Mode Timing Diagram for Internal Clock

SCIn isosynchronous mode timings — external clock

timing requirements for external clock SCIn isosynchronous mode⁽¹⁾⁽²⁾ (see Figure 16)

NO.		MIN	MAX	UNIT
1	$t_{c(SCC)}$ Cycle time, SCInCLK ⁽³⁾	$8t_{c(ICKL)}$		ns
2	$t_{w(SCCH)}$ Pulse duration, SCInCLK high	$0.5t_{c(SCC)} - 0.25t_{c(ICKL)}$	$0.5t_{c(SCC)} + 0.25t_{c(ICKL)}$	ns
3	$t_{w(SCCL)}$ Pulse duration, SCInCLK low	$0.5t_{c(SCC)} - 0.25t_{c(ICKL)}$	$0.5t_{c(SCC)} + 0.25t_{c(ICKL)}$	ns
4	$t_{d(SCCH-TXV)}$ Delay time, SCInCLK high to SCInTX valid	$2t_{c(ICKL)} + 12 + t_r$		ns
5	$t_{v(TX)}$ Valid time, SCInTX data after SCInCLK low	$2t_{c(SCC)} - 10$		ns
6	$t_{su(RX-SCCL)}$ Setup time, SCInRX before SCInCLK low	0		ns
7	$t_{v(SCCL-RX)}$ Valid time, SCInRX data after SCInCLK low	$2t_{c(ICKL)} + 10$		ns

1 $t_{c(ICKL)}$ = interface clock cycle time = $1/f_{(ICKL)}$

2 For rise and fall timings, see the "switching characteristics for output timings versus load capacitance" table.

3 When driving an external SCInCLK, the following must be true: $t_{c(SCC)} \geq 8t_{c(ICKL)}$

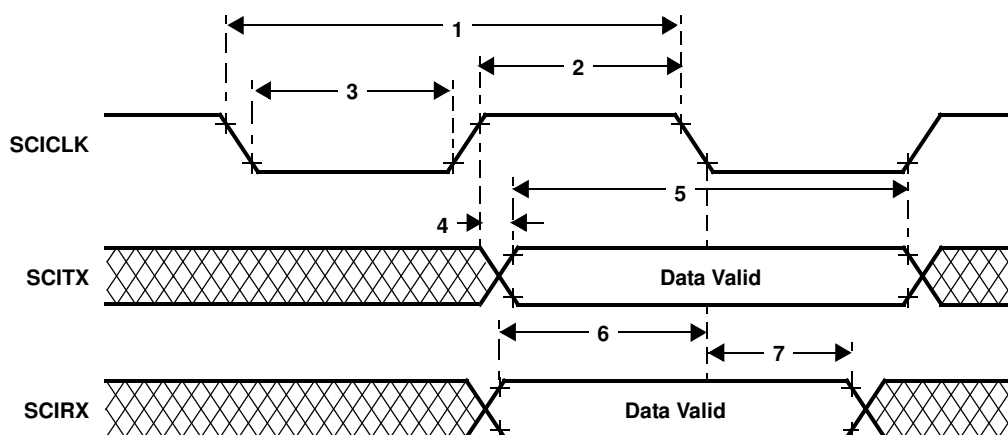

NOTE A: Data transmission/reception characteristics for isosynchronous mode with external clocking are similar to the asynchronous mode. Data transmission occurs on the SCICLK rising edge, and data reception on the SCICLK falling edge.

Figure 16. SCIn Isosynchronous Mode Timing Diagram for External Clock

TMS470R1VF689, TMS470R1VF688 16/32-BIT RISC FLASH MICROCONTROLLERS

SPNS001I – FEBRUARY 2002 – REVISED AUGUST 2005

I2C timing

Table 12 below assumes testing over recommended operating conditions.

Table 12. I2C Signals (SDA and SCL) Switching Characteristics⁽¹⁾

PARAMETER		STANDARD MODE		FAST MODE		UNIT
		MIN	MAX	MIN	MAX	
$t_{c(I2CCLK)}$	Cycle time, I2C module clock	75	150	75	150	ns
$t_{c(SCL)}$	Cycle time, SCL	10		2.5		μ s
$t_{su(SCLH-SDAL)}$	Setup time, SCL high before SDA low (for a repeated START condition)	4.7		0.6		μ s
$t_{h(SCLL-SDAL)}$	Hold time, SCL low after SDA low (for a repeated START condition)	4		0.6		μ s
$t_{w(SCLL)}$	Pulse duration, SCL low	4.7		1.3		μ s
$t_{w(SCLH)}$	Pulse duration, SCL high	4		0.6		μ s
$t_{su(SDA-SCLH)}$	Setup time, SDA valid before SCL high	250		100		ns
$t_{h(SDA-SCLL)}$	Hold time, SDA valid after SCL low	0	3.45 ⁽²⁾	0	0.9	μ s
$t_{w(SDAH)}$	Pulse duration, SDA high between STOP and START conditions	4.7		1.3		μ s
$t_{su(SCLH-SDAH)}$	Setup time, SCL high before SDA high (for STOP condition)	4.0		0.6		μ s
$t_{w(SP)}$	Pulse duration, spike (must be suppressed)			0	50	ns
C_b ⁽³⁾	Capacitive load for each bus line		400		400	pF

1 The I2C pins SDA and SCL do not feature fail-safe I/O buffers. These pins could potentially draw current when the device is powered down.

2 The maximum $t_{h(SDA-SCLL)}$ for I2C bus devices has only to be met if the device does not stretch the low period ($t_{w(SCLL)}$) of the SCL signal.

3 C_b = The total capacitance of one bus line in pF.

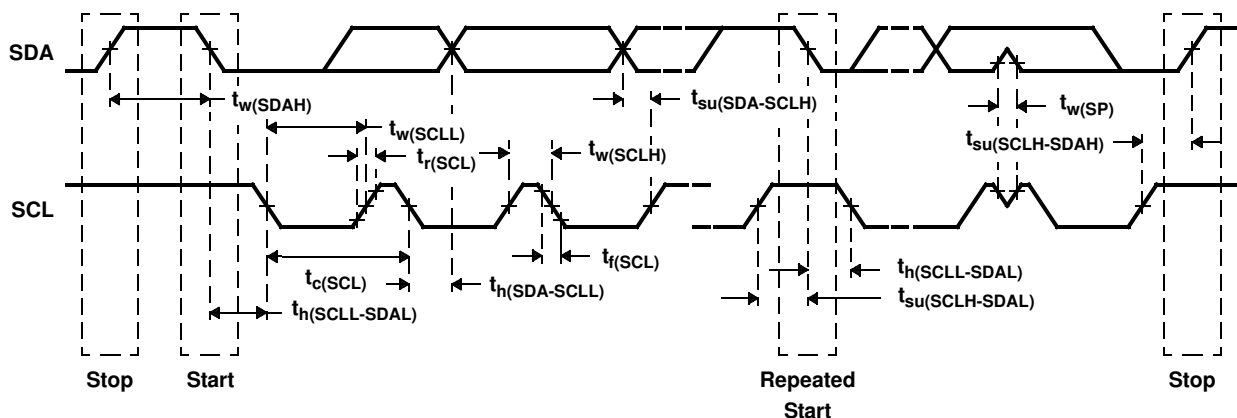

- A device must internally provide a hold time of at least 300 ns for the SDA signal (referred to the V_{IHmin} of the SCL signal) to bridge the undefined region of the falling edge of SCL.
- The maximum $t_{h(SDA-SCLL)}$ has only to be met if the device does not stretch the LOW period ($t_{w(SCLL)}$) of the SCL signal.
- A Fast-mode I2C-bus device can be used in a Standard-mode I2C-bus system, but the requirement $t_{su(SDA-SCLH)} \geq 250$ ns must then be met. This will automatically be the case if the device does not stretch the LOW period of the SCL signal. If such a device does stretch the LOW period of the SCL signal, it must output the next data bit to the SDA line $t_r \max + t_{su(SDA-SCLH)}$.
- C_b = total capacitance of one bus line in pF. If mixed with fast-mode devices, faster fall-times are allowed

Figure 17. I2C Timings

TMS470R1VF689, TMS470R1VF688 16/32-BIT RISC FLASH MICROCONTROLLERS

SPNS0011 – FEBRUARY 2002 – REVISED AUGUST 2005

standard CAN controller (SCC) mode timings

dynamic characteristics for the CANSTX and CANSRX pins

PARAMETER		MIN	MAX	UNIT
$t_d(\text{CANSTX})$	Delay time, transmit shift register to CANSTX pin ⁽¹⁾		15	ns
$t_d(\text{CANSRX})$	Delay time, CANSRX pin to receive shift register		5	ns

1 These values do not include rise/fall times of the output buffer.

expansion bus timing parameters, $-40^\circ\text{C} \leq T_J \leq 150^\circ\text{C}$, $3.0\text{ V} \leq V_{CC} \leq 3.6\text{ V}$

(see figure 18 and figure 19)

NO.	PARAMETER		MIN	MAX	UNIT
1	$t_c(\text{CO})$	Cycle time, CLKOUT	20.8		ns
2	$t_d(\text{COH-EBADV})$	Delay Time, CLKOUT high to EBADDR valid		21.4	ns
3	$t_h(\text{COH-EBADIV})$	Hold Time, EBADDR invalid after CLKOUT high		12.4	ns
4	$t_d(\text{COH-EBOE})$	Delay Time, CLKOUT high to $\overline{\text{EBOE}}$ fall		11.4	ns
5	$t_h(\text{COH-EBOEH})$	Hold Time, $\overline{\text{EBOE}}$ rise after CLKOUT high		11.4	ns
6	$t_d(\text{COL-EBWR})$	Delay Time, CLKOUT low to write strobe ($\overline{\text{EBWR}}$) low		11.3	ns
7	$t_h(\text{COL-EBWRH})$	Hold Time, $\overline{\text{EBWR}}$ high after CLKOUT low		11.6	ns
8	$t_{su}(\text{EBRDATV-COH})$	Setup time, EBDATA valid before CLKOUT high (READ) ⁽²⁾	15.2		ns
9	$t_h(\text{COH-EBRDATIV})$	Hold time, EBDATA invalid after CLKOUT high (READ)		(– 14.7)	ns
10	$t_d(\text{COL-EBWDATV})$	Delay time, CLKOUT low to EBDATA valid (WRITE) ⁽³⁾		16.1	ns
11	$t_h(\text{COL-EBWDATIV})$	Hold time, EBDATA invalid after CLKOUT low (WRITE)		14.7	ns
SECONDARY TIMES					
12	$t_d(\text{COH-EBCS0})$	Delay, CLKOUT high to $\overline{\text{EBCS0}}$ fall		13.6	ns
13	$t_h(\text{COH-EBCS0H})$	Hold, $\overline{\text{EBCS0}}$ rise after CLKOUT high		13.2	ns
14	$t_{su}(\text{COH-EBHOLDL})$	Setup time, $\overline{\text{EBHOLD}}$ low to CLKOUT high ⁽²⁾	10.9		ns
15	$t_{su}(\text{COH-EBHOLDH})$	Setup time, $\overline{\text{EBHOLD}}$ high to CLKOUT high ⁽²⁾	10.5		ns

2 Setup time is the minimum time under worst case conditions. Data with less setup time will not work.

3 Valid after CLKOUT goes low for write cycles.

TMS470R1VF689, TMS470R1VF688 16/32-BIT RISC FLASH MICROCONTROLLERS

SPNS001I – FEBRUARY 2002 – REVISED AUGUST 2005

expansion bus module timing

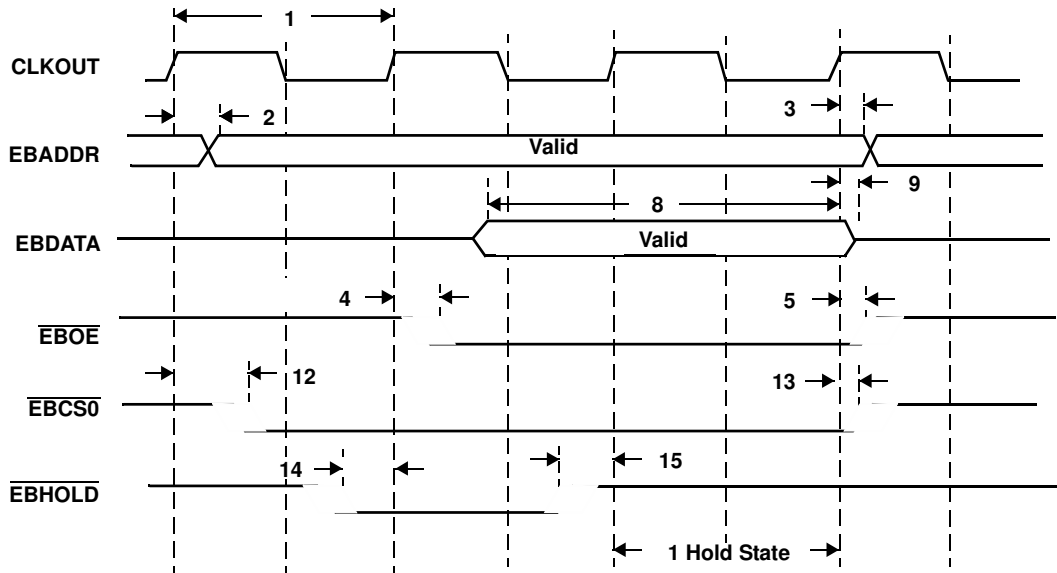

Figure 18. Expansion Memory Signal Timing - Reads

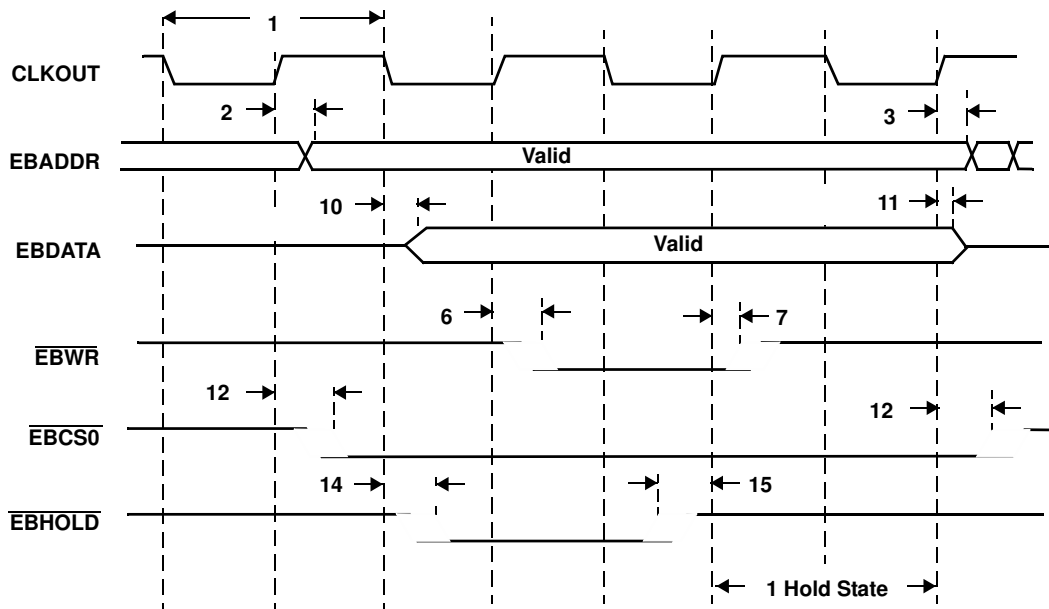

Figure 19. Expansion Memory Signal Timing - Writes

TMS470R1VF689, TMS470R1VF688 16/32-BIT RISC FLASH MICROCONTROLLERS

SPNS0011 – FEBRUARY 2002 – REVISED AUGUST 2005

class 2 serial interface B (C2Slb) variable pulse width (vpw) modulation

vpw timing requirements

PARAMETER		NORMAL MODE (10.4 KBPS)				4X MODE (41.6 KBPS)				UNIT
		TX		RX		TX		RX		
		MIN	MAX	MIN	MAX	MIN	MAX	MIN	MAX	
SOF	Start of frame	192	208	163	239	48	52	41	60	μs
Short Pulse	Low = 0	60	68	34	96	14	18	9	24	μs
	High = 1									μs
Long Pulse	Low = 1	122	134	97	163	30	34	24	41	μs
	High = 0									μs
EOD	End of data	193	207	164	239	48	52	41	60	μs
NB	Normalization bit (long)	122	134	97	163	30	34	24	41	μs
	Normalization bit (short)	60	68	34	96	14	18	9	24	μs
EOF	End of frame	271	289	240	320	67	73	60	80	μs
Break	Short	290	-	239	-	290	-	60	-	μs
	Long	758	-	239	-	758	-	60	-	μs

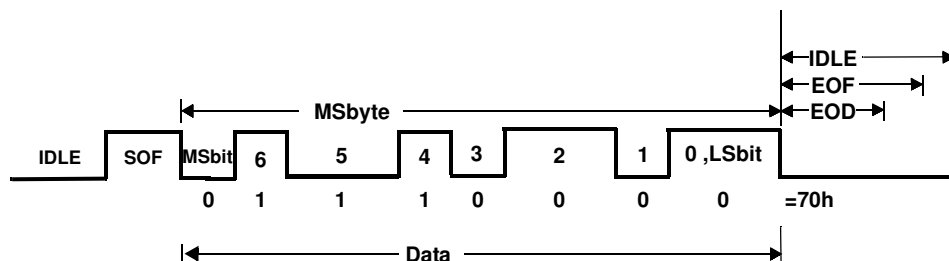

Figure 20. C2Slb Timing Diagram

TMS470R1VF689, TMS470R1VF688

16/32-BIT RISC FLASH MICROCONTROLLERS

SPNS001I – FEBRUARY 2002 – REVISED AUGUST 2005

high-end timer (HET) timings

minimum PWM output pulse width:

This is equal to one High Resolution Clock Period (HRP). The HRP is defined by the 6-bit High Resolution Prescale Factor (hr) which is user defined, giving prescale factors of 1 to 64, with a linear increment of codes.

Therefore, the minimum PWM output pulse width = $HRP(\min) = hr(\min)/SYSCLK = 1/SYSCLK$

For example, for a SYSCLK of 30 MHz, the minimum PWM output pulse width = $1/30 = 33.33\text{ns}$

minimum input pulses we can capture:

The input pulse width must be greater or equal to the Low Resolution Clock Period (LRP), i.e., the HET loop (the HET program must fit within the LRP). The LRP is defined by the 3-bit Loop-Resolution Prescale Factor (lr), which is user defined, with a power of 2 increment of codes. That is, the value of lr can be 1, 2, 4, 8, 16, or 32.

Therefore, the minimum input pulse width = $LRP(\min) = hr(\min) * lr(\min)/SYSCLK = 1 * 1/SYSCLK$

For example, with a SYSCLK of 30 MHz, the minimum input pulse width = $1 * 1/30 = 33.33 \text{ ns}$

Note: Once the input pulse width is greater than LRP, the resolution of the measurement is still HRP. (That is, the captured value gives the number of HRP clocks inside the pulse.)

Abbreviations:

High resolution clock period = $HRP = hr/SYSCLK$

Loop resolution clock period = $LRP = hr*lr/SYSCLK$

hr = HET high resolution divide rate = 1, 2, 3,...63, 64

lr = HET low resolution divide rate = 1, 2, 4, 8, 16, 32

multi-buffered A-to-D converter (MibADC)

The multi-buffered A-to-D converter (MibADC) has a separate power bus for its analog circuitry that enhances the A-to-D performance by preventing digital switching noise on the logic circuitry which could be present on V_{SS} and V_{CC} from coupling into the A-to-D analog stage. All A-to-D specifications are given with respect to AD_{REFLO} unless otherwise noted.

Resolution 10 bits (1024 values)
 Monotonic Assured
 Output conversion code 00h to 3FFh [00 for $V_{AI} \leq AD_{REFLO}$; 3FF for $V_{AI} \geq AD_{REFHI}$]

MibADC recommended operating conditions⁽¹⁾

		MIN	MAX	UNIT
AD_{REFHI}	A-to-D high -voltage reference source	V_{SSAD}	V_{CCAD}	V
AD_{REFLO}	A-to-D low-voltage reference source	V_{SSAD}	V_{CCAD}	V
V_{AI}	Analog input voltage	$V_{SSAD} - 0.3$	$V_{CCAD} + 0.3$	V
I_{AIC}	Analog input clamp current ⁽²⁾ ($V_{AI} < V_{SSAD} - 0.3$ or $V_{AI} > V_{CCAD} + 0.3$)	- 2	2	mA

1 For V_{CCAD} and V_{SSAD} recommended operating conditions, see the "device recommended operating conditions" table.

2 Input currents into any ADC input channel outside the specified limits could affect conversion results of other channels.

operating characteristics over full ranges of recommended operating conditions⁽³⁾⁽⁴⁾

PARAMETER	DESCRIPTION/CONDITIONS	MIN	TYP	MAX	UNIT	
R_i	Analog input resistance	See Figure 21		250	500	Ω
C_i	Analog input capacitance	See Figure 21		Conversion	10	pF
				Sampling	30	pF
I_{AIL}	Analog input leakage current	See Figure 21		-1	1	μ A
$I_{ADREFHI}$	AD_{REFHI} input current	$AD_{REFHI} = 3.6$ V, $AD_{REFLO} = V_{SSAD}$			5	mA
CR	Conversion range over which specified accuracy is maintained	$AD_{REFHI} - AD_{REFLO}$		3	3.6	V
E_{DNL}	Differential nonlinearity error	Difference between the actual step width and the ideal value. (See Figure 22)			± 2	LSB
E_{INL}	Integral nonlinearity error	Maximum deviation from the best straight line through the MibADC. MibADC transfer characteristics, excluding the quantization error. (See Figure 23)			± 2	LSB
E_{TOT}	Total error/Absolute accuracy	Maximum value of the difference between an analog value and the ideal midstep value. (See Figure 24)			± 2	LSB

3 $V_{CCAD} = AD_{REFHI}$

4 1 LSB = $(AD_{REFHI} - AD_{REFLO})/2^{10}$ for the MibADC

TMS470R1VF689, TMS470R1VF688 16/32-BIT RISC FLASH MICROCONTROLLERS

SPNS001I – FEBRUARY 2002 – REVISED AUGUST 2005

multi-buffered A-to-D converter (MibADC) (continued)

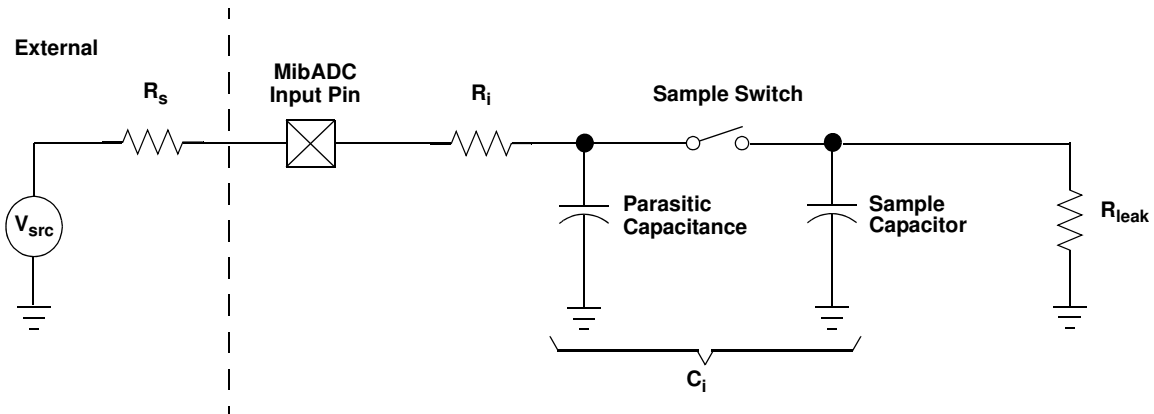

Figure 21. MibADC Input Equivalent Circuit

multi-buffer ADC timing requirements

		MIN	NOM	MAX	UNIT
$t_{c(ADCLK)}$	Cycle time, MibADC clock	0.05			μs
$t_{d(SH)}$	Delay time, sample and hold time	1			μs
$t_{d(C)}$	Delay time, conversion time	0.55			μs
$t_{d(SHC)}^{(1)}$	Delay time, total sample/hold and conversion time	1.55			μs

1 This is the minimum sample/hold and conversion time that can be achieved. These parameters are dependent on many factors; for more details, see the *TMS470R1x Multi-Buffered Analog-to-Digital Converter (MibADC) Reference Guide* (literature number SPNU206).

multi-buffered A-to-D converter (MibADC) (continued)

The differential nonlinearity error shown in Figure 22 (sometimes referred to as differential linearity) is the difference between an actual step width and the ideal value of 1 LSB.

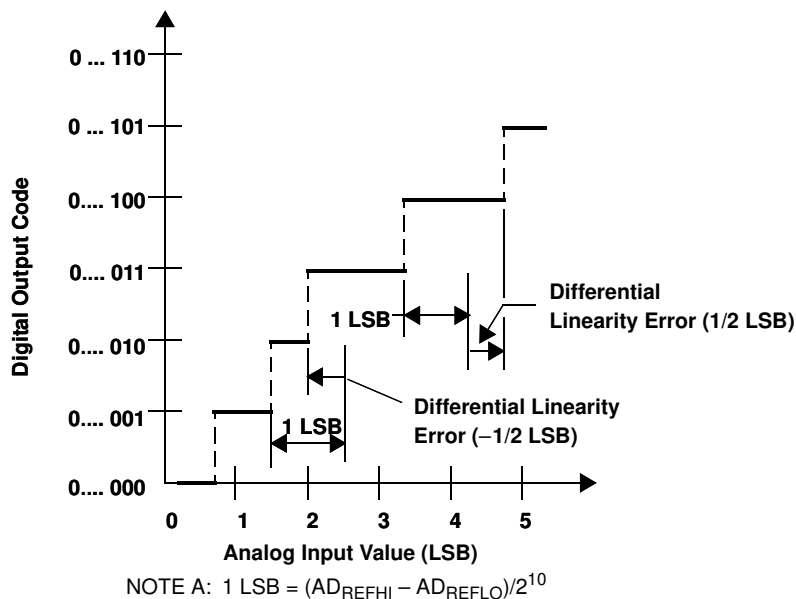

Figure 22. Differential Nonlinearity (DNL)

The integral nonlinearity error shown in Figure 23 (sometimes referred to as linearity error) is the deviation of the values on the actual transfer function from a straight line.

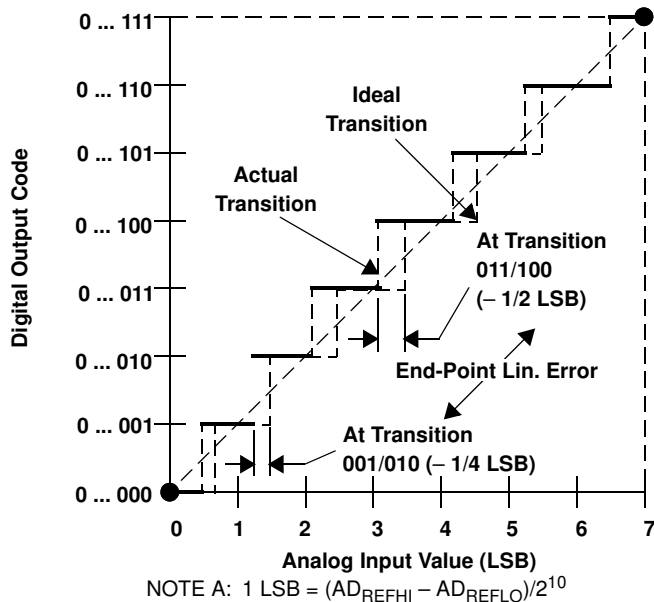

Figure 23. Integral Nonlinearity (INL) Error

TMS470R1VF689, TMS470R1VF688 16/32-BIT RISC FLASH MICROCONTROLLERS

SPNS001I – FEBRUARY 2002 – REVISED AUGUST 2005

multi-buffer A-to-D converter (MibADC) (continued)

The absolute accuracy or total error of an MibADC as shown in Figure 24 is the maximum value of the difference between an analog value and the ideal midstep value.

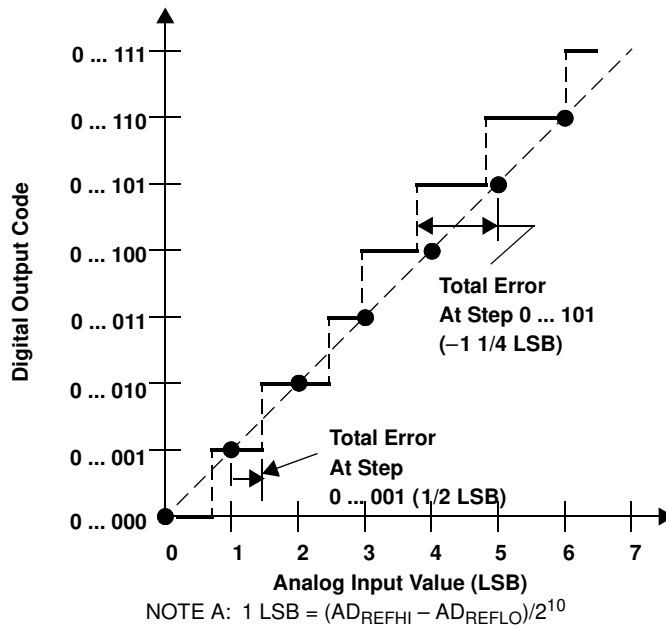

Figure 24. Absolute Accuracy (Total) Error

TMS470R1VF689, TMS470R1VF688 16/32-BIT RISC FLASH MICROCONTROLLERS

SPNS0011 – FEBRUARY 2002 – REVISED AUGUST 2005

MECHANICAL DATA

PGE (S-PQFP-G144)

PLASTIC QUAD FLATPACK

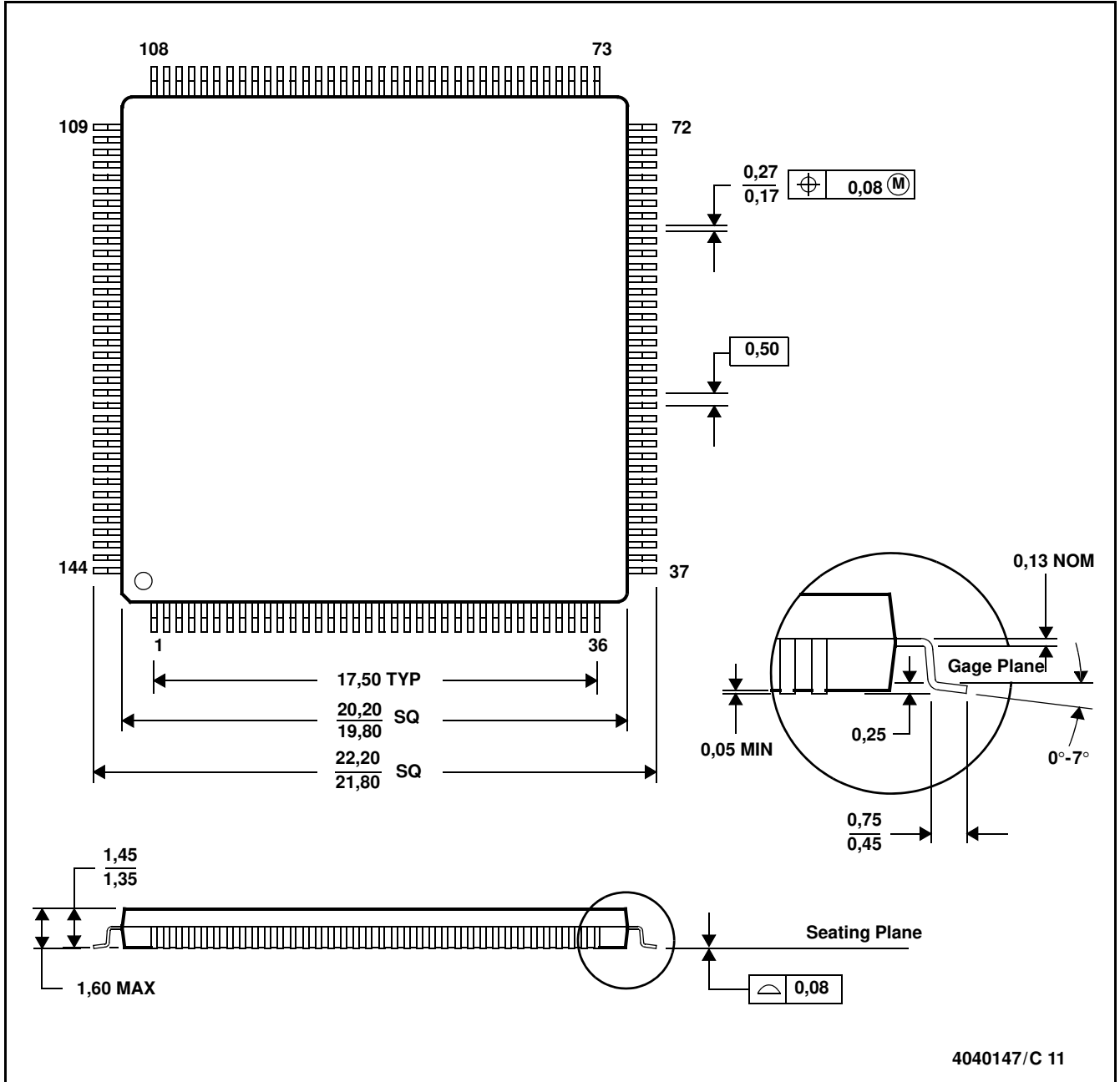

- NOTES: A. All linear dimensions are in millimeters.
 B. This drawing is subject to change without notice.
 C. Falls within JEDEC MS-026

Thermal Resistance Characteristics

PARAMETER	°C/W
$R_{\theta JA}$	43
$R_{\theta JC}$	5

TMS470R1VF689, TMS470R1VF688 16/32-BIT RISC FLASH MICROCONTROLLERS

SPNS001I – FEBRUARY 2002 – REVISED AUGUST 2005

MECHANICAL DATA

PZ (S-PQFP-G100)

PLASTIC QUAD FLATPACK

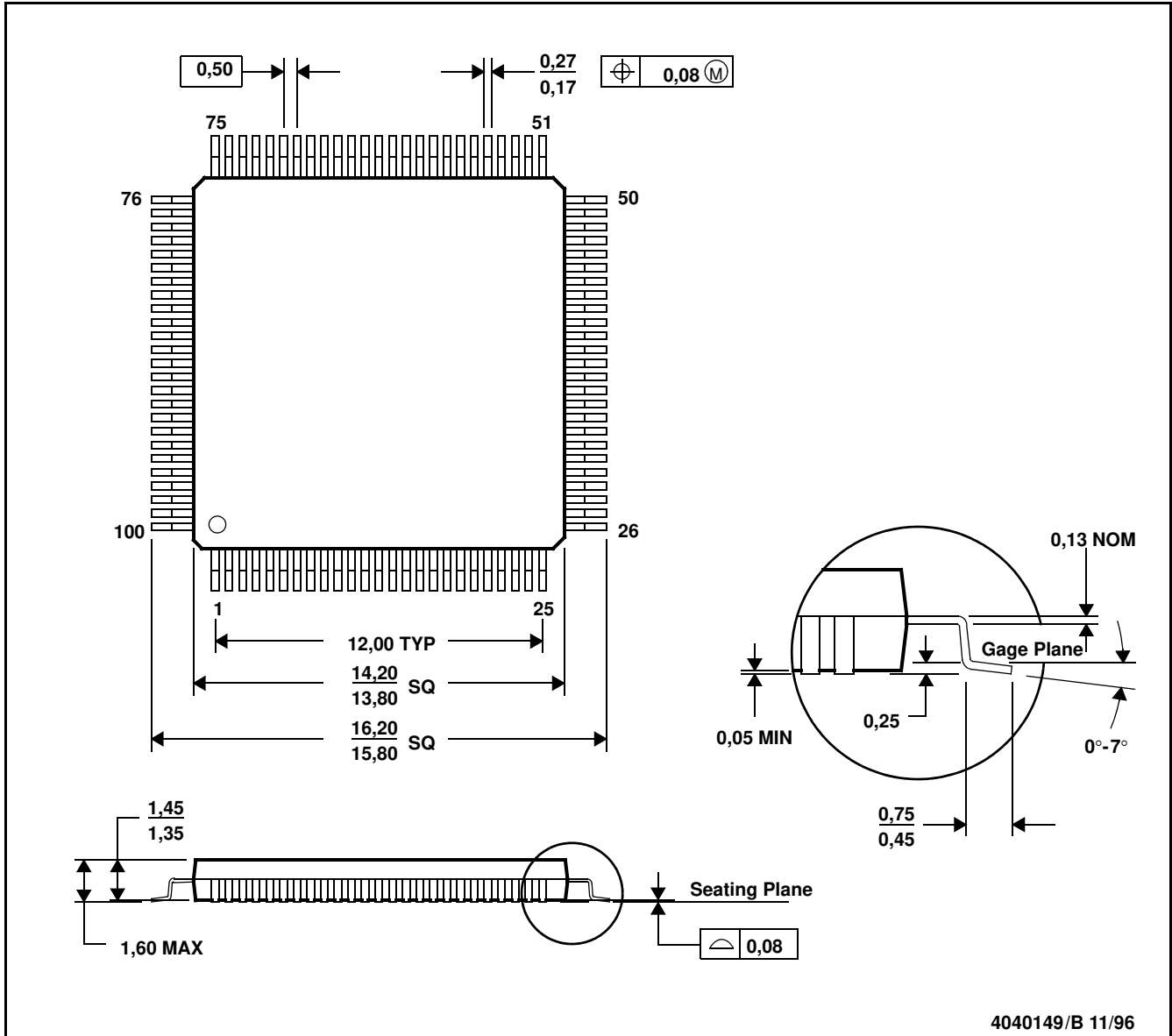

- NOTES: A. All linear dimensions are in millimeters.
 B. This drawing is subject to change without notice.
 C. Falls within JEDEC MS-026

Thermal Resistance Characteristics

PARAMETER	°C/W
$R_{\theta JA}$	48
$R_{\theta JC}$	5

List of Figures

- [TMS470R1VF689x 100-Pin PZ Package \(TOP VIEW\)](#)
- [TMS470R1VF689x 144-Pin PGE Package \(TOP VIEW\) \(without Expansion Bus\)](#)
- [TMS470R1VF689x 144-Pin PGE Package \(TOP VIEW\) \(with Expansion Bus\)](#)
- [Functional Block Diagram \(VF689\)](#)
- [Functional Block Diagram \(VF688\)](#)
- Figure 1. [TMS470R1VF689 Memory Map](#)
- Figure 2. [TMS470R1VF688 Memory Map](#)
- Figure 3. [TMS470R1x Family Nomenclature](#)
- Figure 4. [Test Load Circuit](#)
- Figure 5. [Crystal/Clock Connection](#)
- Figure 6. [CLKOUT Timing Diagram](#)
- Figure 7. [ECLK Timing Diagram](#)
- Figure 8. [PORRST Timing Diagram](#)
- Figure 9. [CMOS-Level Outputs](#)
- Figure 10. [CMOS-Level Inputs](#)
- Figure 11. [SPIn Master Mode External Timing \(CLOCK PHASE = 0\)](#)
- Figure 12. [SPIn Master Mode External Timing \(CLOCK PHASE = 1\)](#)
- Figure 13. [SPIn Slave Mode External Timing \(CLOCK PHASE = 0\)](#)
- Figure 14. [SPIn Slave Mode External Timing \(CLOCK PHASE = 1\)](#)
- Figure 15. [SCIn Isosynchronous Mode Timing Diagram for Internal Clock](#)
- Figure 16. [SCIn Isosynchronous Mode Timing Diagram for External Clock](#)
- Figure 17. [I2C Timings](#)
- Figure 18. [Expansion Memory Signal Timing - Reads](#)
- Figure 19. [Expansion Memory Signal Timing - Writes](#)
- Figure 20. [C2Slb Timing Diagram](#)
- Figure 21. [MibADC Input Equivalent Circuit](#)
- Figure 22. [Differential Nonlinearity \(DNL\)](#)
- Figure 23. [Integral Nonlinearity \(INL\) Error](#)
- Figure 24. [Absolute Accuracy \(Total\) Error](#)
- [Mechanical Data](#)
- [Mechanical Data](#)

TMS470R1VF689, TMS470R1VF688

16/32-BIT RISC FLASH MICROCONTROLLERS

SPNS001I – FEBRUARY 2002 – REVISED AUGUST 2005

List of Tables

Table 1.	Device Characteristics
Table 2.	TMS470R1VF689 Memory Selection Assignment
Table 3.	TMS470R1VF688 Memory Selection Assignment
Table 4.	VF689/VF688 Peripherals, System Module, and Flash Base Addresses
Table 5.	DMA Request Lines Connections
Table 6.	Interrupt Priority (IEM and CIM)
Table 7.	Expansion Bus Mux Mapping(1)
Table 8.	Expansion Bus Pins
Table 9.	MibADC Event Hookup Configuration
Table 10.	TMS470 Device ID Bit Allocation Register
Table 11.	Device Part Number
Table 12.	I2C Signals (SDA and SCL) Switching Characteristics

TMS470R1VF689, TMS470R1VF688
16/32-BIT RISC FLASH MICROCONTROLLERS
REVISION HISTORY

REVISION HISTORY

REV	DATE	NOTES
1	8/05	<p>Updates:</p> <p>Page 18, added decoded block size for flash memory.</p> <p>Page 18, moved paragraph about XOR share feature to Description section.</p> <p>Page 18, added footnote to Table 2.</p> <p>Page 22, changed "System Address" to 0xFFFF_FFCC.</p> <p>Page 26, changed footnote to Table 7 to refer to documentation only.</p> <p>Page 26, added footnote to Table 7.</p> <p>Page 26, updated pin definitions in Table 8.</p> <p>Page 33, updated input clamp current maximum ratings.</p> <p>Page 35, removed ICLK parameter from I_{CC} test conditions.</p> <p>Page 35, removed "all frequencies" from halt test conditions.</p> <p>Page 35, changed "all frequencies" to "No DC load" for I_{CCAD} standby test condition.</p> <p>Page 35, updated I_{CC} operating and standby values at 85C.</p> <p>Page 35, added I_{CC}, I_{CCIO}, I_{CCAD}, and I_{CCP} halt values at 30C.</p> <p>Page 35, added I_{CC}, I_{CCIO}, I_{CCAD}, and I_{CCP} halt values at 85C.</p> <p>Page 39, changed f_(OSCRST) value from MAX to TYP.</p> <p>Page 41, V_{CCIOPORH} value of 2.75V identified as a minimum.</p> <p>Page 41, removed note about timing requirements from timing requirements for <u>PORRST</u> table.</p> <p>Page 41, added t_{fsu} to the 'switching characteristics over recommended operating conditions for RST' table'.</p> <p>Page 41, added t_{fp}(<u>RST</u>), t_{fp}(<u>SLEEP</u>), and t_{fp}(<u>STDBY</u>) to the timing requirements for program flash.</p> <p>Page 56, changed min and max for both modes of I2C module clock.</p> <p>Page 61, removed reference to V_{CC} in note under operating characteristics table.</p>

IMPORTANT NOTICE

Texas Instruments Incorporated and its subsidiaries (TI) reserve the right to make corrections, modifications, enhancements, improvements, and other changes to its products and services at any time and to discontinue any product or service without notice. Customers should obtain the latest relevant information before placing orders and should verify that such information is current and complete. All products are sold subject to TI's terms and conditions of sale supplied at the time of order acknowledgment.

TI warrants performance of its hardware products to the specifications applicable at the time of sale in accordance with TI's standard warranty. Testing and other quality control techniques are used to the extent TI deems necessary to support this warranty. Except where mandated by government requirements, testing of all parameters of each product is not necessarily performed.

TI assumes no liability for applications assistance or customer product design. Customers are responsible for their products and applications using TI components. To minimize the risks associated with customer products and applications, customers should provide adequate design and operating safeguards.

TI does not warrant or represent that any license, either express or implied, is granted under any TI patent right, copyright, mask work right, or other TI intellectual property right relating to any combination, machine, or process in which TI products or services are used. Information published by TI regarding third-party products or services does not constitute a license from TI to use such products or services or a warranty or endorsement thereof. Use of such information may require a license from a third party under the patents or other intellectual property of the third party, or a license from TI under the patents or other intellectual property of TI.

Reproduction of information in TI data books or data sheets is permissible only if reproduction is without alteration and is accompanied by all associated warranties, conditions, limitations, and notices. Reproduction of this information with alteration is an unfair and deceptive business practice. TI is not responsible or liable for such altered documentation.

Resale of TI products or services with statements different from or beyond the parameters stated by TI for that product or service voids all express and any implied warranties for the associated TI product or service and is an unfair and deceptive business practice. TI is not responsible or liable for any such statements.

Following are URLs where you can obtain information on other Texas Instruments products and application solutions:

Products

Amplifiers	amplifier.ti.com
Data Converters	dataconverter.ti.com
DSP	dsp.ti.com
Interface	interface.ti.com
Logic	logic.ti.com
Power Mgmt	power.ti.com
Microcontrollers	microcontroller.ti.com

Applications

Audio	www.ti.com/audio
Automotive	www.ti.com/automotive
Broadband	www.ti.com/broadband
Digital Control	www.ti.com/digitalcontrol
Military	www.ti.com/military
Optical Networking	www.ti.com/opticalnetwork
Security	www.ti.com/security
Telephony	www.ti.com/telephony
Video & Imaging	www.ti.com/video
Wireless	www.ti.com/wireless

Mailing Address: Texas Instruments
Post Office Box 655303 Dallas, Texas 75265