

INSTRUCTION MANUAL	
IS-8048E	
ISSUED	1998-06-02
REVISED	2005-10-28
REV.	D

MFB MANUAL TERMINATOR

(Tool Number: 57831-5000)

OPERATING MANUAL



Molex Japan Co., Ltd.

Molex Japan Co., Ltd.		Contents of Update		Instruction Manual No.		IS-8048E		
Title		MFB Manual Terminator			Tool Number		57831-5000	
Rev.	Issued	Description						
0	1998/06/02	New creation release. ECN-JM80007						
A	2000/10/27	Added the standard value of termination depth and the regular inspection sheet. ECN-JM10013						
B	2001/07/16	Revised the form to the MS-Word. ECN-JM20001						
C	2002/02/18	Added the quality precaution and the startup checklist. ECN-JM20008						
D	2005/10/28	Revised the form to the bilingual version. ECN-JM60008			Prepared by	Y. Ishiwata		
					Checked by	T. Yoshida		
					Approved by	A. Horino		

Table of Contents

	Page
<Safety Precautions>	
1. Introduction	A-1
2. To operation supervisors	A-1
3. Dangerous operations	A-1
4. Careful handling	A-2
5. Installation site	A-2
<Quality Precautions>	
1. Introduction	B-1
2. Must be carried out	B-1
3. Must not be carried out	B-1
1. Description	1
2. Tool Configuration and Applicable Products	
2.1. Tool Name and Configuration	1
2.2. Applicable Connector and Cable	1
2.3. Tool Appearance and Each Part Name	2
2.4. Circuit Number Assignment	2
3. Specifications	
3.1. Tool Specifications	3
3.2. Outside Dimensions and Weight	3
3.3. Operating Environment Conditions	3
3.4. Installation Space	4
4. Work Procedure	
4.1. MFB Termination Flow	5
4.2. Prior Processing of Cable	7
5. Work Method	
5.1. Setting of Connector and Cut-die (C/D-row)	8
5.2. Wire Arrangement of C-row	9
5.3. Knack of Wire Arrangement	10
5.4. Termination of C-row	11
5.5. Wire Arrangement of D-row	12
5.6. Termination of D-row	13
5.7. Cable Reversing (Shift to A/B-row)	14
6. Maintenance and Check	
6.1. Daily Maintenance	15
6.2. Checking of Tool	16
6.3. Measurement Method of Termination Depth	17
6.4. Exchange Method of IDT (Termination) Punch	18
6.5. Adjustment Method of Hand Press Bottom Dead Point	19
7. Parts List	
7.1. Slide Table Development	20
7.2. Termination Tool Development	21
7.3. Parts List	22
8. Startup Checklist	23

<Safety Precautions>

Please read the following before operating the tool.

1. Introduction

Thank you for choosing our **MFB Manual Terminator**.

This instruction manual is prepared so that the tool is properly used. Please take the time to read this manual, making sure you understand the operating procedures described herein before attempting to operate the tool.

2. To operation supervisors

- 1) Operators should fully understand the contents of this manual before operation.
- 2) If operators do not understand English, translate this manual into the proper language.
- 3) Keep this manual near the tool so that operators can refer to it anytime.

3. Dangerous operations

Observe the following precautions to prevent a life-threatening accident.

- 1) Don't insert a part of your body or other foreign materials into the tool when you are using the lever of a tool
- 2) Don't place the tool on an unstable, off-balanced worktable from which the tool might fall down.
- 3) If more than two operators are engaged in operation or checkup at the same time, even slight miscommunication might lead to a serious accident.

Caution

- 1) Unauthorized reproduction of this document in part or in whole is prohibited.
- 2) The contents of this document are subject to change without notice.
- 3) Molex Japan Co., Ltd. assumes no responsibility for losses resulting from use or misuse of this document.

<Safety Precautions>

Please read the following before operating the tool.

4. Careful handling

Keep the items below to use the tool safely and properly.

* Please contact our application-tooling group if something's wrong with the tool.

1) Tool malfunctions

If you notice any unusual sound or movement in the tool, stop the operation immediately and check the suspicious parts.

2) Foreign materials entering

If foreign materials such as water or metals accidentally get inside the tool, stop the operation immediately and remove those materials.

5. Installation site

Be careful about the following items when you install the tool.

1) Temperature and humidity

Don't operate the tool in extremely high/low temperature or extremely high humidity.

* Place it where the temperature is stable around 23 degrees centigrade and the air is well ventilated.

2) Dust and corrosive gas

It will become the cause of failure if dust, corrosive gas, etc. are in the circumference of this tool.

* Please don't install this tool to such a place.

3) Unstable work table

When this tool is set up in an unbalance worktable, it not only becomes a dangerous operation but also there is a case to cause the tool damage and it is dangerous.

* Please fix the tool on a stable table horizontally.

<Quality Precautions>

You surely carry out the following for defect-free production.

1. Introduction

In order not to produce a defective article with this tool, this chapter has described “Must be carried out”, and “Must not be carried out” as an important matter on work.

Keep in mind that there is a possibility that a defective article will be produced when not protecting this.

2. Must be carried out

Please be sure to perform the following matter to maintain product quality.

1) Enforcement of startup check

Please check the tool in accordance with the “startup checklist” described in this document before a work start, and start work after confirming nothing is wrong with the tool.

* If the check is neglected, there is a possibility that a defective article will be produced.

2) Confirmation of quality

Please start the production after confirming the quality of a product picked up from the first work, and it passes all of the claims required in the I/O cable specification of a corresponding connector.

* It is recommended to initiate the work on the preferable condition that enough margins for the standard are identified.

3. Must not be carried out

Please don't perform the following matter by any means to maintain product quality.

1) Using of unqualified I/O cable

Please don't use an unqualified I/O cable. There is a possibility of causing connector breakage and termination defect by mismatching of a wire outside diameter.

* Please work using a qualified I/O cable.

2) Terminating a wire too much deeply

Don't terminate a wire too much deeply. It may lead to the breakage of a connector and an IDT punch.

* Please terminate the wire in the appropriate termination height.

3) Termination with a lot of crossed-wire

Because the termination with a lot of crossed-wire in the root of the cable has the case where the connector cannot be installed, it is a prohibition.

* Please start the termination work after arranging the wire well beforehand.

1. Description

This tool is a manual termination tool that has the function to terminate 24 all circuits repeating the operation that terminates the wire of the cable to 2.0mm grid MFB (Molex Future Bus +) connector (four rows × six circuits) of Molex every one row six times.

As a feature, it has the function that cuts the excess length of the arranged wire by the IDT (termination) punch and guides the wire for termination with the cut-die near the terminal, and crimps the wire to the “O” crimp shape lightly in the central part of the terminal at the same time as termination.

This tool is composed of two kinds of termination tools for the A/D-row and for the B/C-row.

2. Tool Configuration and Applicable Products

2.1. Tool Name and Configuration

- 1) Tool name: MFB Manual Terminator
- 2) Tool number: 57831-5000
- 3) Tool configuration:
 - (1) Termination Tool
Two kinds for A/D-row and for B/C-row
 - (2) Slide table and connector holder (Each one)
 - (3) Cut-die
Two kinds for A/D-row and for B/C-row

2.2. Applicable Connector and Cable

- 1) Connector: Molex MFB connector (4 rows × 6 circuits = 24 circuits)
54128-2401: MFB Conn. Housing Sub-ASS'Y
- 2) Cable: UL20276 AWG #30 Multi cores cable with braid shield or Molex qualified cable, Diameter of wire insulation = $\phi 0.48\text{mm}$, Outside diameter of cable = $\phi 5.3 \pm 0.5\text{mm}$

2.3. Tool Appearance and Unit Name

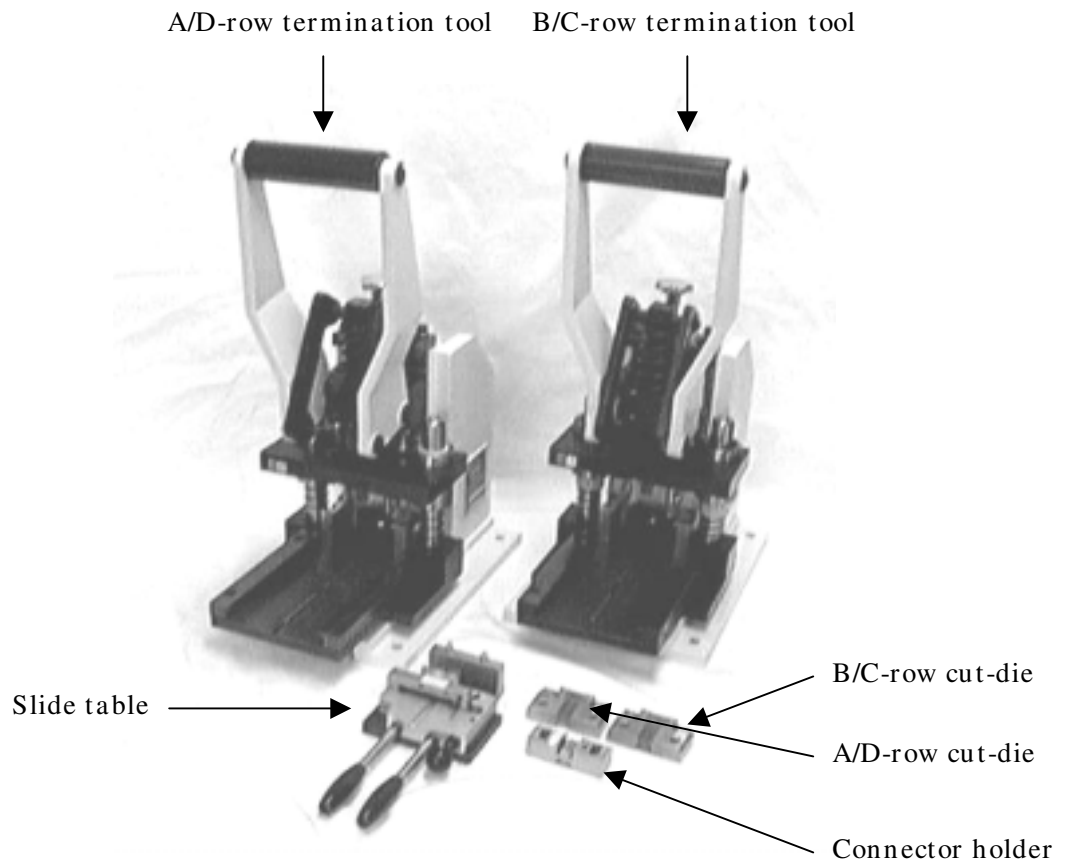

2.4. Circuit Number Assignment

<Circuit number assignment at the view of termination side>

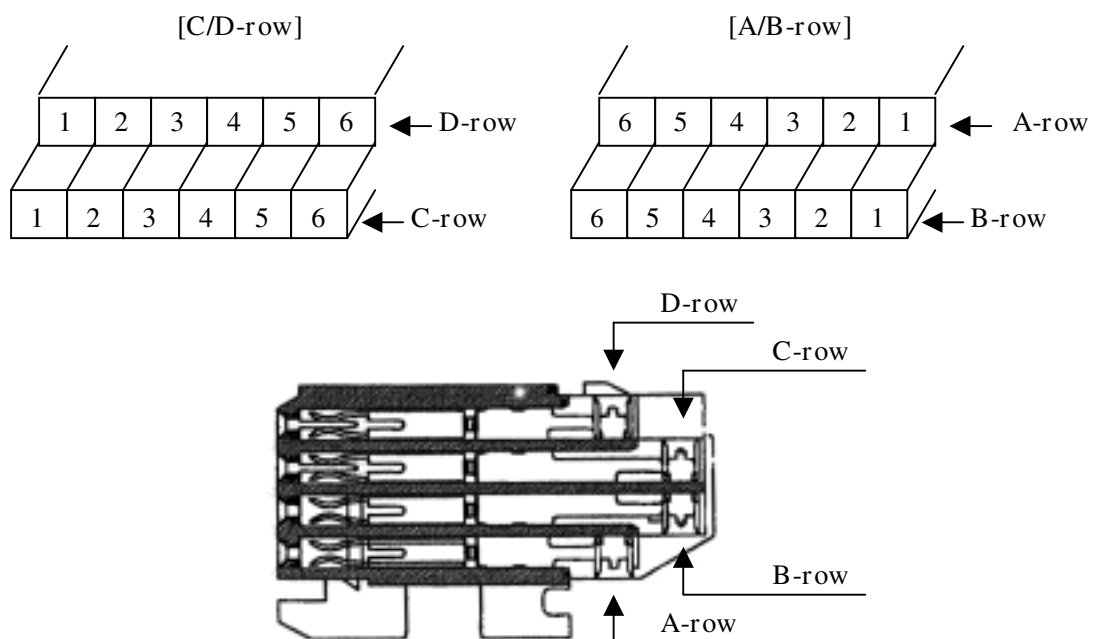

3. Specifications

3.1. Tool Specifications

- 1) Sheath strip length: 80mm or more.
- 2) Shortest cable length: 200mm or more (Size between connectors)
- 3) Termination possible circuit number: Six circuits /row (Correspond to D-row from A-row)
- 4) Wire arrangement method: Method that worker arranges one wire in a prescribed circuit of the cut-die of the slide table.
- 5) Termination method: Termination method that does batch termination after the excess length of the wire arranged in the cut-die is cut by the termination punch.
* The termination of D-row from A-row is executed repeating the wire arrangement and the termination of each row.
- 6) Order of termination: The termination of each row is executed in the following order.
(1) C-row → (2) D-row → "Cable is reversed" → (3) B-row → (4) A-row
- 7) Productivity (Reference): Approx. 960 seconds (16 minutes) /cable → Approx. 3.7 cables /hour
* It is a total processing hour when the connector is terminated to both ends of the cable.
* However, the cable end processing time doesn't contain it.

3.2. Outside Dimensions and Weight

- 1) Outside dimensions: 180 (width) × 380 (depth) × 440 (height) mm × two units
- 2) Weight: Approx. 36kgf (18kgf × two units)

3.3. Operating Environment Conditions

- 1) Operating ambient temperature: 5 -35 degrees centigrade (Away from direct sunlight)
- 2) Operating ambient humidity: 35% - 85% RH (No condensation)
- 3) Operating atmosphere: Atmosphere should be free of corrosive gases and contaminants such as dust or lint.

3.4. Installation Space

Tool installation space on a worktable required for the purposes of performing operation and maintenance checkups.

900 (width) × 900 (depth) × 1600 (height) mm

* Recommended worktable construction: Anti-vibration feature such as adjuster feet and the like. (Load capacity: 200kgf or more)

4. Work Procedure

4.1. MFB Termination Flow (Outline)

The outline of the MFB connector termination flow is shown below.

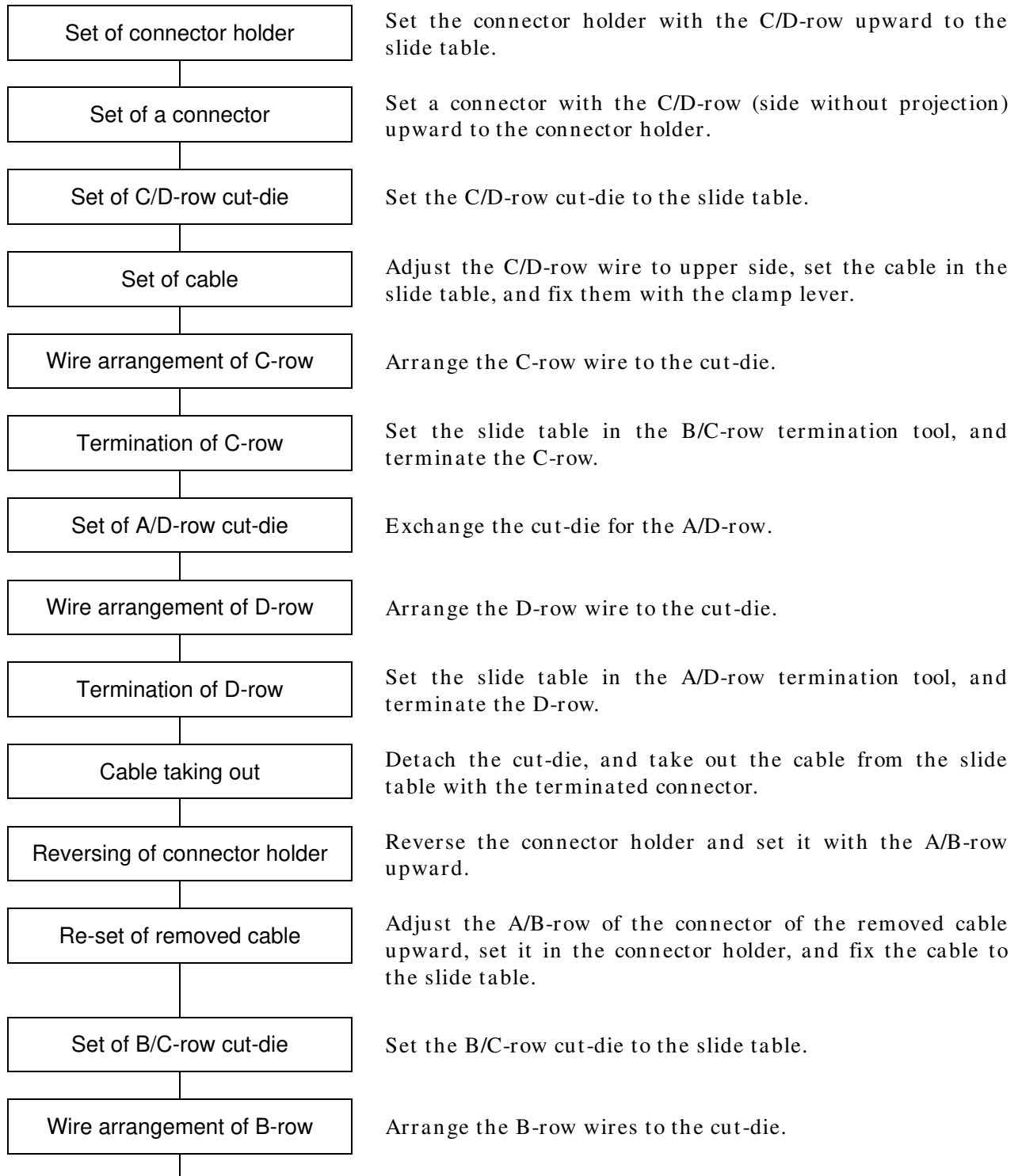

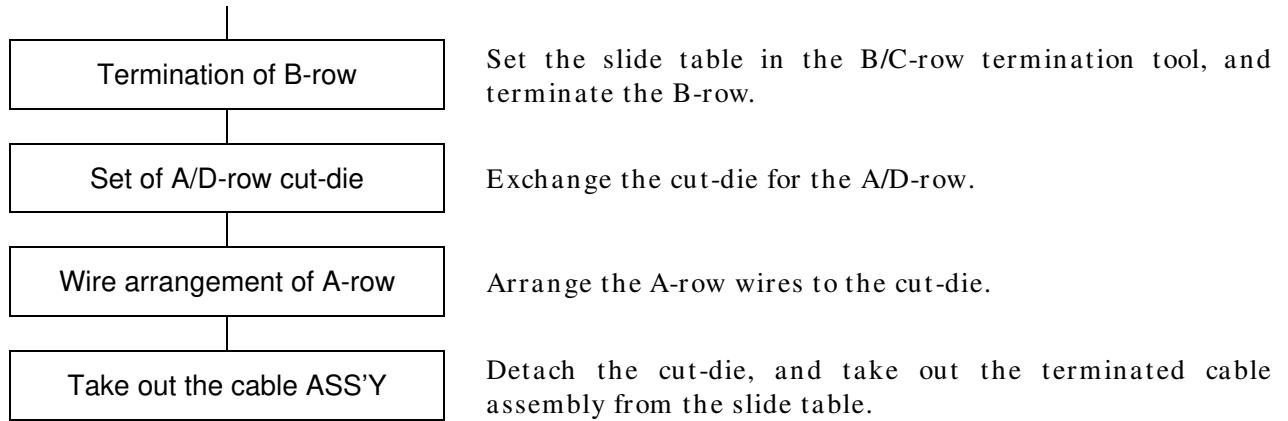

4.2. Prior Processing of Cable

1) Stripping length of sheath

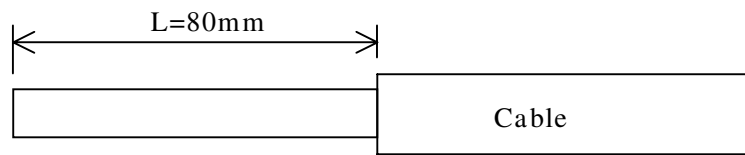

Strip the sheath of a cable with 80mm length.

2) Processing of shield wire

Cut a “braid shield wire” and the “control paper” of its inner side at the sheath end, and the drain wire is left.

3) Group division of pair wire

Divide the pair wires into two at following “A/B-row group” and “C/D-row group”.

No.	Wire group	Number of pair wire
1	A/B-row group	6 pairs
2	C/D-row group	6 pairs

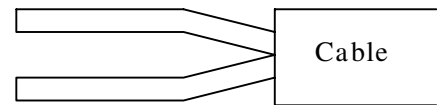

4) Cutting of an unnecessary wire

Cut an unnecessary wire at the sheath end.
The drain wire is terminated instead of the cut wire.

5) Processing of drain wire

Insert the insulation tube (outside diameter $\phi 0.65\text{mm}$) of 50mm length in the drain wire, and bent little the tip of the drain wire so that the insulation tube should not come off.

5. Work Method

5.1. Setting of Connector and Cut-die (C/D-row)

- 1) Put the “slide table (1)” on the work position, and set the “connector holder (2)” in the slide table upward (for two row connector). → The “guide hole (3)” is arranged right.
- 2) Set a “connector (4)” in the “connector holder (2)” in a prescribed direction and confirm the horizontal set.
- 3) Next, set the “B/C-row cut-die” on the connector of the “slide table (1)”.

“Note” The state that the cut-die floats causes a defective termination in the imperfect setting of the connector. Please do the set over again from the beginning.

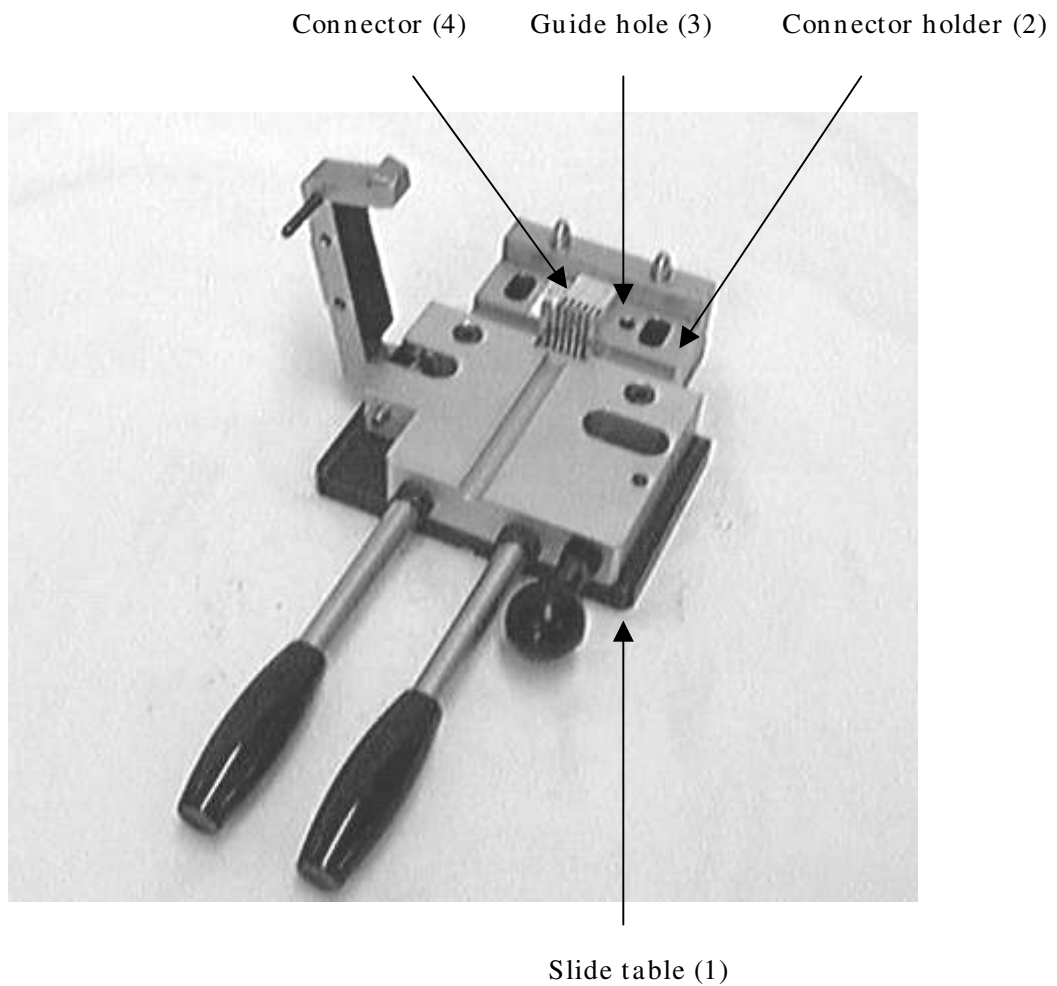

5.2. Wire Arrangement of C-row

- 1) Turn the A/B-row wire under the cable, and arrange the “cable (1)” in the “U-ditch (3)” of the “slide table (2)” with the “C/D-row wire” upward.
- 2) Match the “sheath edge” of the cable to the “wire guide comb (4)”, and fix the “cable (1)” and the “A/B-row wire” with the “clamp lever (5)”.
- 3) Untwist the “pair wire (6)” and separate it to two, and arrange the “C-row wire (7)” in a prescribed circuit of the “B/C-row cut-die (8)”. Push the arranged wire into the “stop comb (9)” with the “wire arrangement tool” and fix it firmly.
- 4) Arrange the “D-row wire (10)” of the pair remainder to the same position of the “temporary stop comb (11)” on the cable clamp.
- 5) Execute the wire arrangement of six pairs that corresponds repeating clause 3 and 4.

“Note” Please note that loosening of the wire by the stop comb causes a defective cutting.

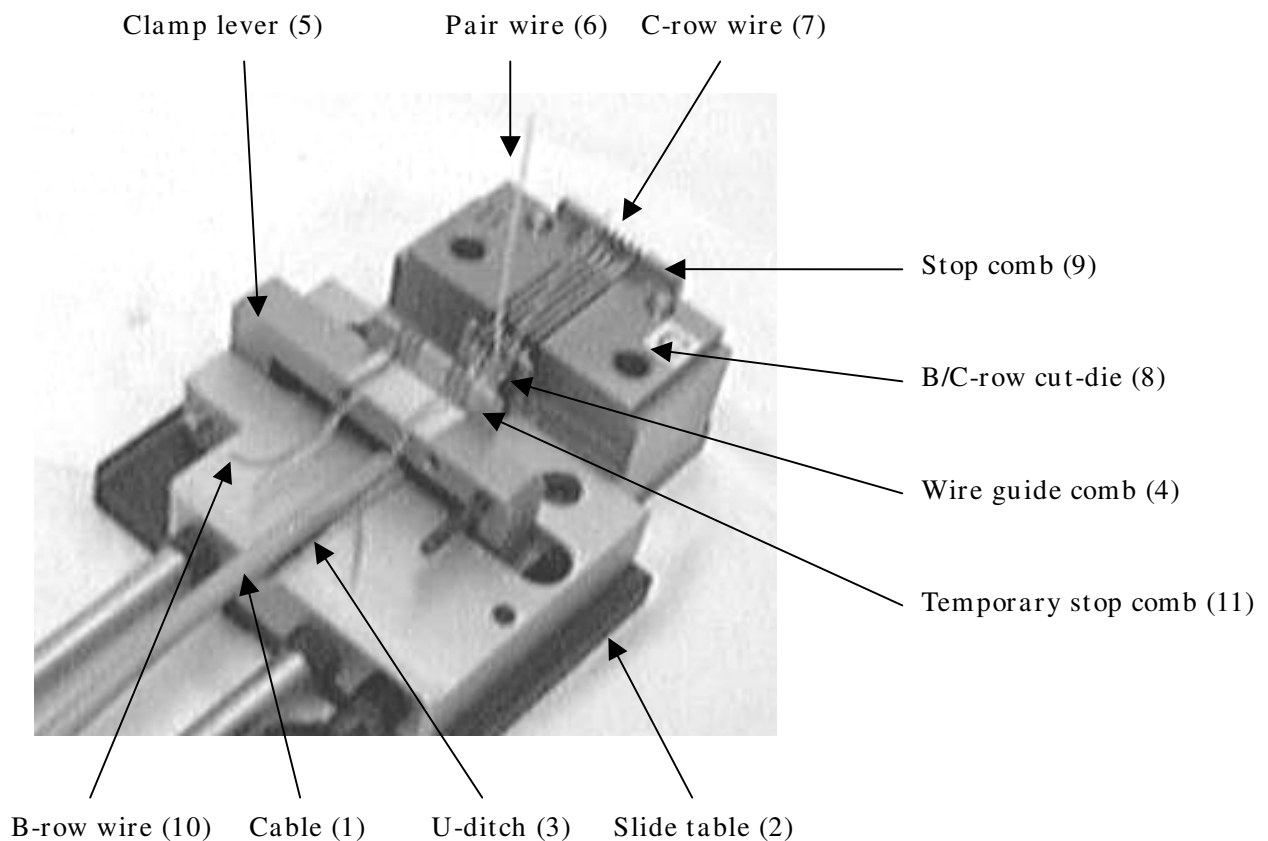

5.3. Knack of Wire Arrangement

- 1) Untwist the twisted pair wire carefully to the root and make the wire straight before wire arrangement.
- 2) When the wire arrangement of all wire in the row ends, depress politely “this side wire (2)” of the “wire guide comb (1)” with the “wire arrangement tool (4)” so that it may become the same level as a center position of the “cable (3)”.
- 3) Next, make “**some loosening**” in the “cut-die side wire (6)” between the “wire guide comb (1)” and the “cut-die (5)” with the “wire arrangement tool (4)”.

“Note” Please note that the upsurge of the this side wire of the wire guide comb causes a “defect of wire protruding length”.

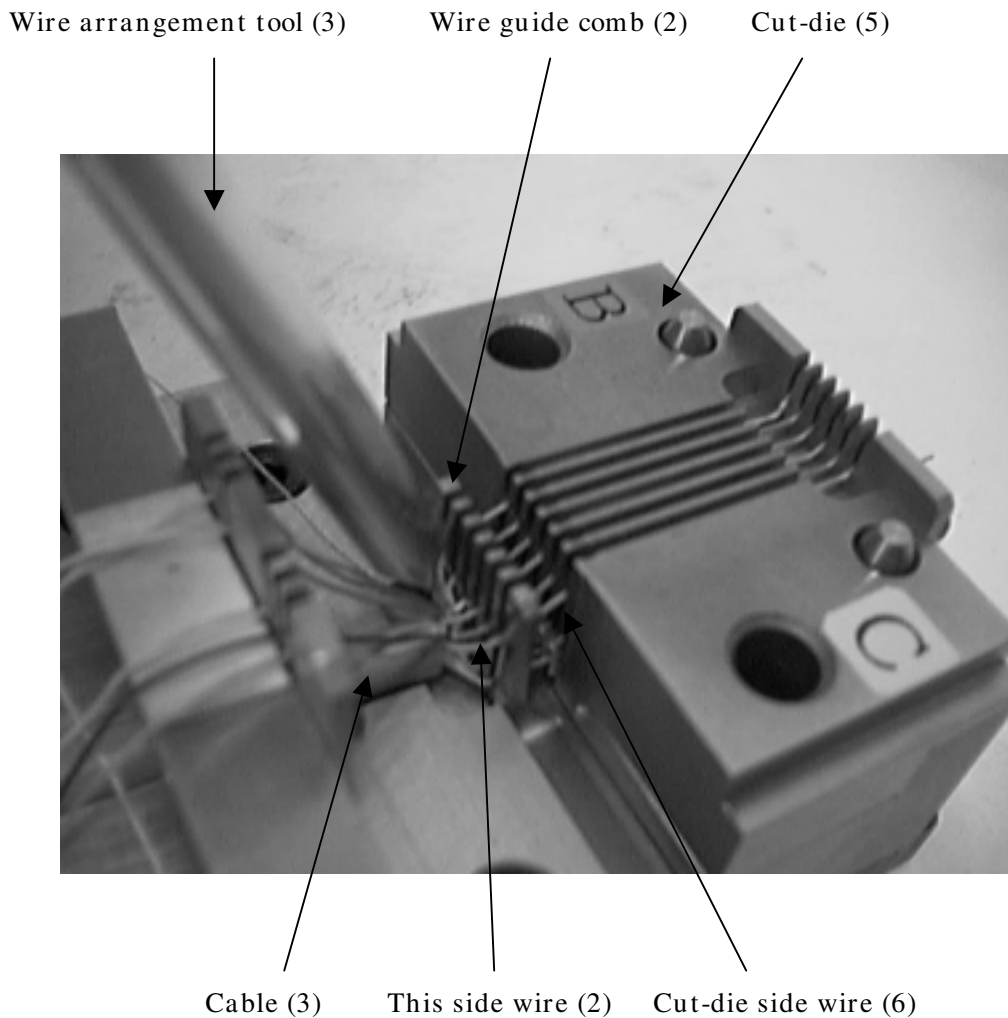

5.4. Termination of C-row

- 1) Grasp the “knob (2)” of the “slide table (1)” by one hand, set it in the “B/C-row termination tool (3)”, and push it into the interior of the tool completely.
- 2) Depress the “handle (4)” of the hand press enough to the operation end by the hand on the other side with the “knob (2)” of the slide table grasped by one hand.
* Execution of the excess length wire cutting and the termination of the C-row.
- 3) Draw out the “slide table (1)” from the tool after termination, remove the “B/C-row cut-die”, and remove the cut wire scrap from the cut-die.

“Note” Please put each hand certainly on the “knob” and the “handle” for safety and operate it.

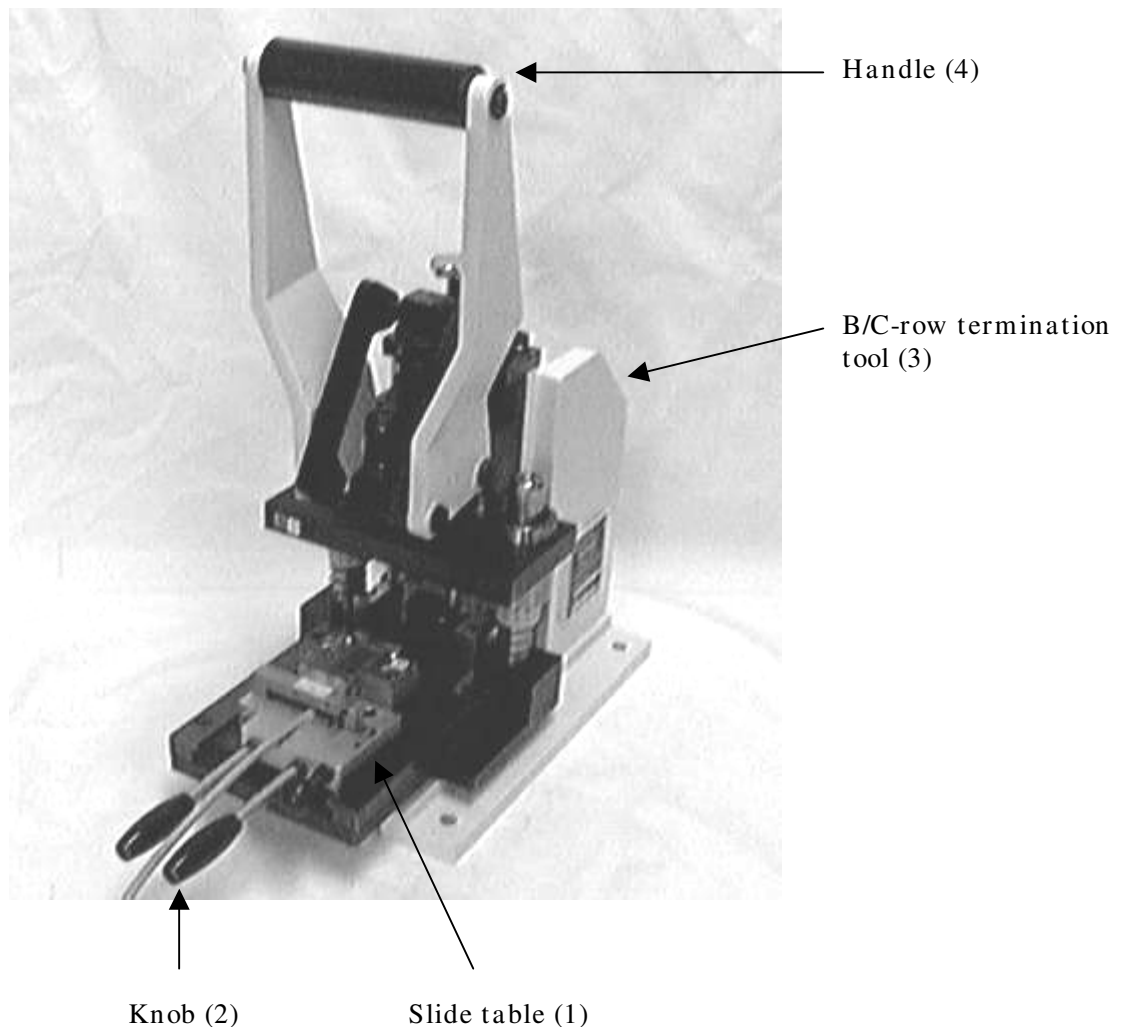

5.5. Wire Arrangement of D-row

- 1) Set the “A/D-row cut-die (2)” on the connector of the “slide table (1)”.
- 2) Remove the “temporary stop wire” from the “temporary stop comb (3)”, pass through the “wire guide comb (4)” in the same circuit, arrange it in the “A/D-row cut-die (2)”, and push it into the “stop comb (5)” with the “wire arrangement tool (6)”.
- 3) Arrange six temporary stop wire sequentially by one.
- 4) When the wire arrangement of all wire in the row ends, depress “this side wire (7)” of the “wire guide comb (4)” with the “wire arrangement tool (6)” to the center position of the cable, and make “**some loosening**” in the “cut-die side wire (8)”.

“**Note**” Please note that it causes the faulty wiring if one is not sequentially arranged.

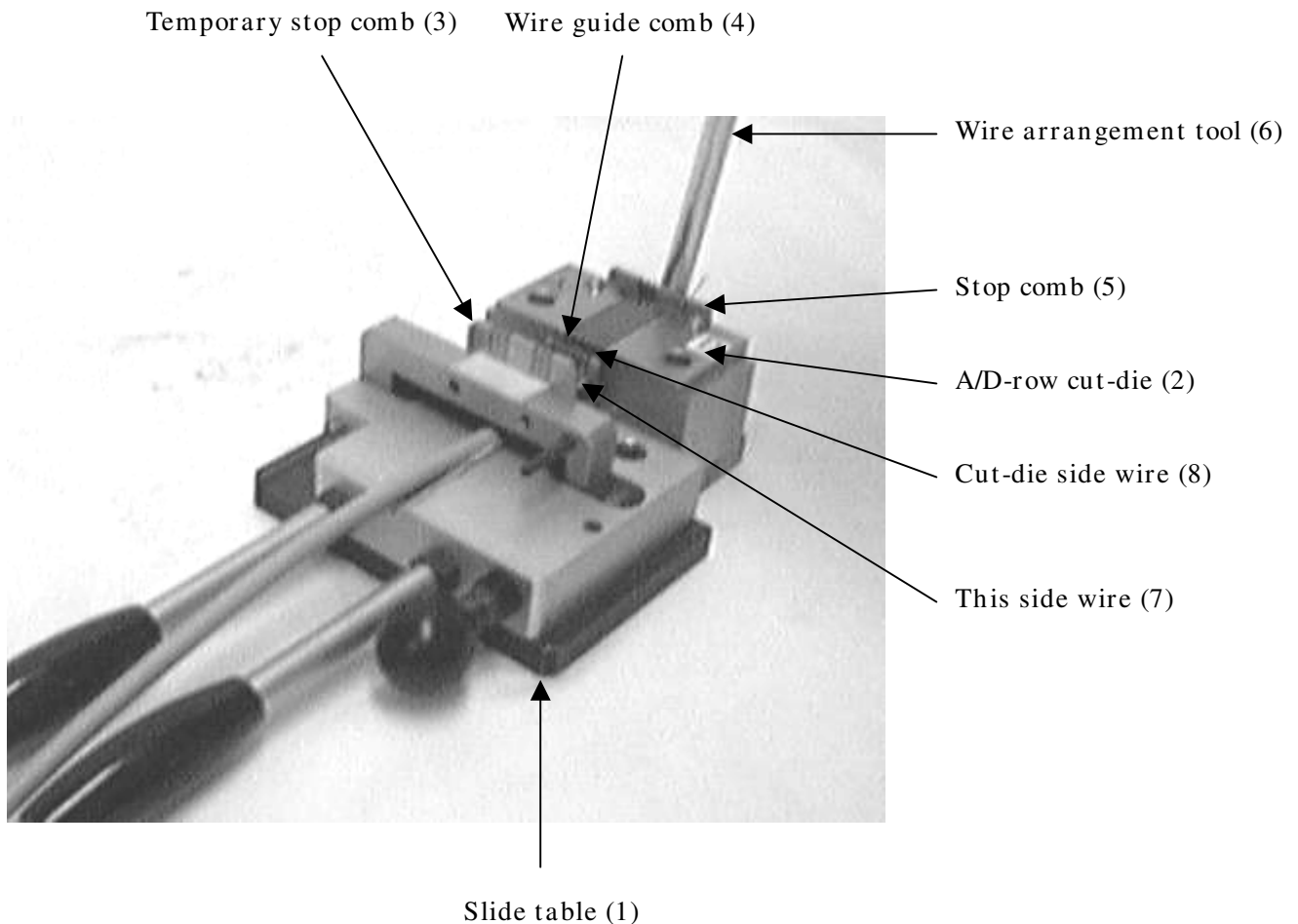

5.6. Termination of D-row

- 1) Grasp the “knob (2)” of the “slide table (1)” by one hand, set it in the “A/D-row termination tool (3)”, and push it into the interior of the tool completely.
- 2) Depress the “handle (4)” of the hand press enough to the operation end by the hand on the other side with the “knob (2)” of the slide table grasped by one hand.
* Execution of the excess length wire cutting and the termination of the D-row.
- 3) Draw out the “slide table (1)” from the tool after termination, remove the “A/D-row cut-die”, and remove the cut wire scrap from the cut-die.

“Note” Please put each hand certainly on the “knob” and the “handle” for safety and operate it.

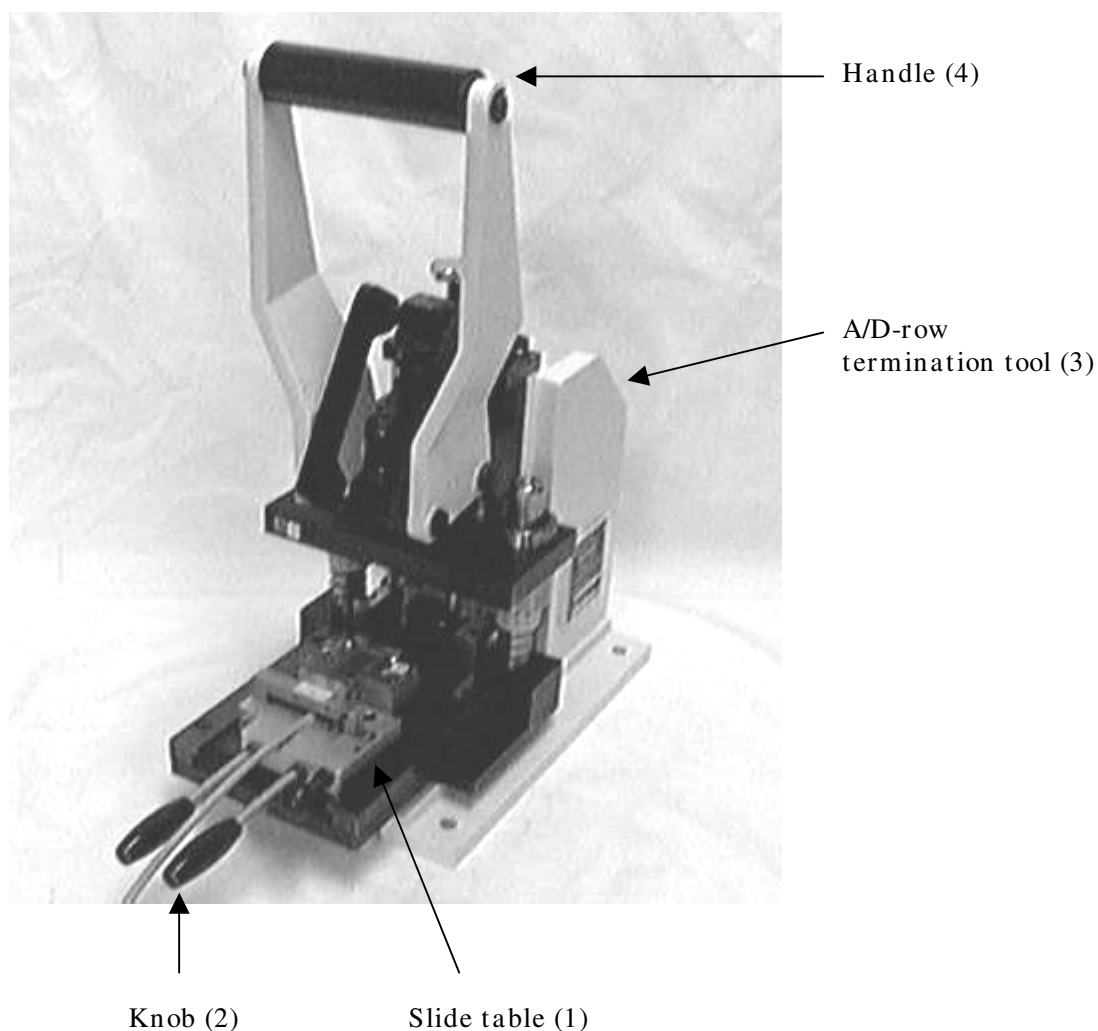

5.7. Cable Reversing (Shift to A/B-row)

- 1) Release the latch of the “clamp lever (2)” pulling the “release knob (1)”, and open the clamping of the cable.
- 2) Remove the “cable assembly (3)” and the “connector holder (5)” from the “slide table (4)” at the same time.

<The following are executed according to the following procedure>

- (1) Reverse the connector holder and set it with the A/B-row upward.
- (2) Reverse the removed cable assembly, and set it in the slide table.
- (3) Execute the B-row termination.
- (4) Execute the A-row termination.
- (5) Detach the cable assembly from the slide table. (Termination completion goods)

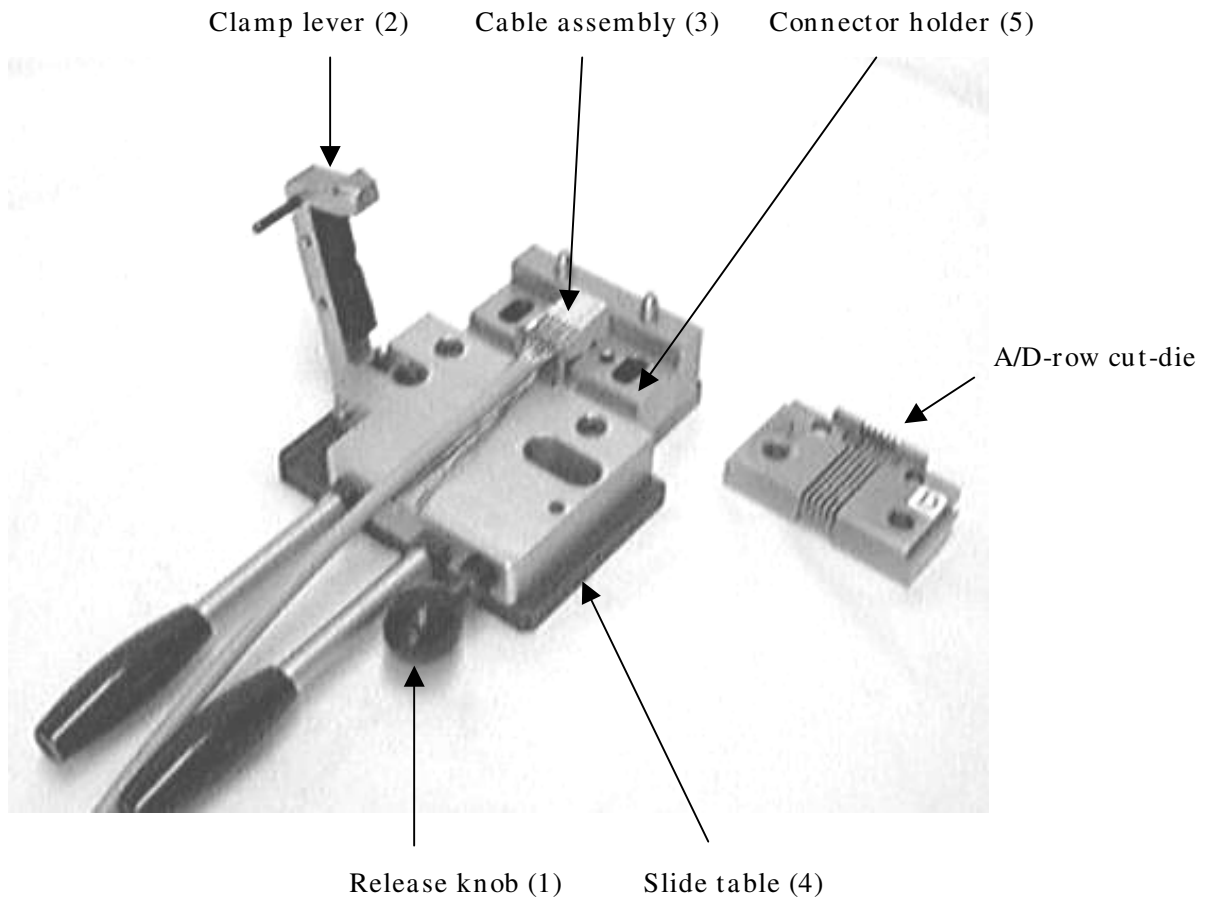

6. Maintenance and Check

6.1. Daily Maintenance

1) Management of tool

Before a work start, please carry out the tool check in accordance with the “startup checklist” in this manual, and start work after checking that it satisfies a standard.

* Please record each check result simultaneously.

2) Removal of foreign substances

Since foreign substances such as dust and wire scrap adhere to the “termination punch”, “cut-die”, “stop comb” and “connector holder”, etc. during operation, please remove a foreign substance timely.

* Neglect may become the cause of a defective termination.

3) Cleaning of work end

Please wipe with a dry cloth lightly after cleaning the tool with compression air every day at the time of a work end. There is an effect that prevents rusting.

4) Lubrication

Please supply proper amount of “Lithium family grease” (JIS No. 2) to the shaft of a die set and the ram of a hand press with the frequency of once a month.

6.2. Checking of Tool

* Please reconfirm the standard value with the IDT specification of MFB connector of the latest version before the work.

1) Termination (IDT) depth

The termination depth of the wire of each row must be the standard value.

<Standard> (UL20276 Phi0.48mm)

Row	Termination depth (mm)
A	0.83 +0.15/-0
B	2.83 +0.15/-0
C	2.63 +0.15/-0
D	0.63 +0.15/-0

“Note” The standard value is different in the wire type.

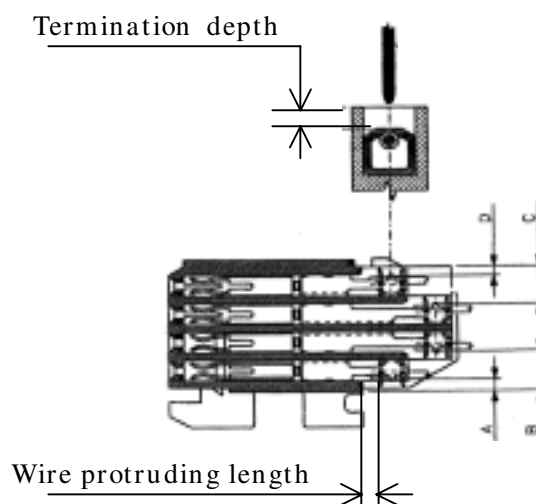

2) Wire protruding length

The wire protruding length must be the standard value.

<Standard> Wire protruding length = 0.8mm or more from the edge of the IDT terminal

3) Shear drop of conductor

The conductor shear-drop amount of the cut wire must be a standard value or less, and it must not be short-circuited between pitches.

<Standard> Conductor shear-drop amount = Do not exceed the outside diameter of the insulation of the wire.

4) Crack on wire insulation

A remarkable crack by the termination punch and the wire guide comb, etc. do not be on the wire insulation.

5) Crack on housing

A remarkable crack by the termination tool does not be on the housing.

6.3. Adjustment Method of Termination Depth

- 1) Loosen the “nut (2)” of the “shank (1)” on the hand press and adjust the bottom dead point of the IDT punch turning the “shank (1).” Tighten the nut after it adjusts and the shank is fixed to the “ram (3).”
- 2) Amount of adjustment and direction
[Amount of adjustment]
One scale = about 0.17mm (One rotation =1.0mm)
[Direction of adjustment]
The wire is deeply pushed: Shank is turned left.
The wire is shallowly pushed: Shank is turned right.
- 3) The “stopper (4)” is adjusted in the position with the space of 0.5mm from the “upper die set (5)” at the bottom dead point of the tool.
* The stopper is for interference prevention of the upper and lower when the die set is removed from the hand press.

“Note” Please start the work after confirming the termination depth of each row meets the standard in the test after adjustment.

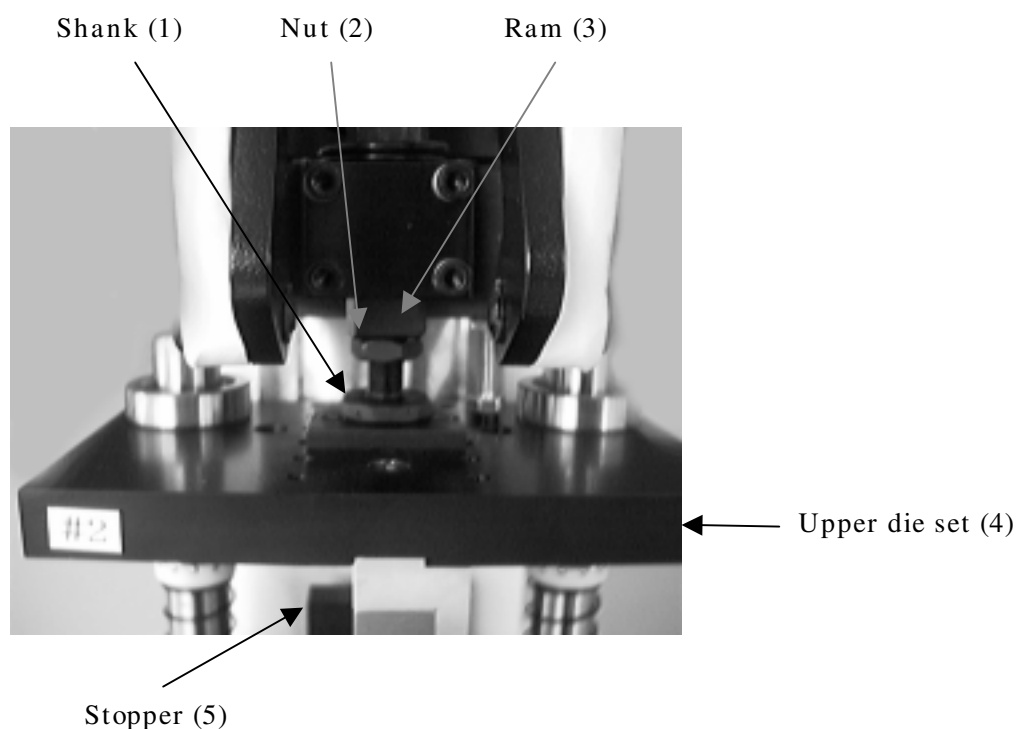

6.4. Exchange Method of IDT (Termination) Punch

1) Detaching of IDT (termination) punch

Detach the "IDT punch (3)" by removing two "screws (2)" of the "upper die-set (1)" of the termination tool.

2) Setting of IDT punch

Set the "IDT punch (3)" of three pieces composition in the "punch holder (4)" in prescribed the order, and fix the screw while pushing the "IDT punch (3)" upward.

"Note" Please set the IDT punch to the punch holder in the following order because the U-ditch for the set mistake prevention has been installed in the top of the IDT punch

The first	Three U-ditches	(11) IDT Punch (Cutting)
The second	Two U-ditches	(12) Crimp Punch
The third	One U-ditch	(13) IDT Punch (Outside)

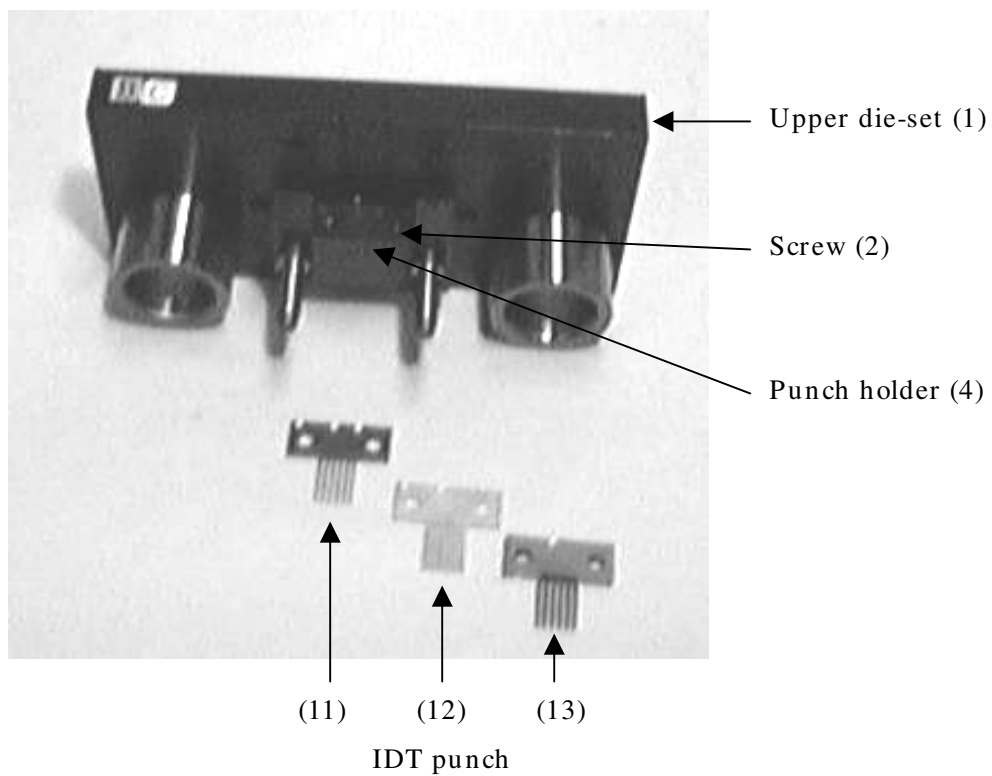

6.5. Adjustment Method of Hand Press Bottom Dead Point

When the adjustment of the termination depth is not good enough by the shank alone, the bottom dead point of the main body of the hand press is adjusted according to the following procedure.

- 1) Loosen the “fixed screw (2)” of the “handle block (1)” of the hand press and adjust the bottom dead point of the main body of the hand press moving the handle block with the “adjustment knob (3).”
- 2) Adjust the screw at the same time when there is a “support screw (4)” in the handle block.
- 3) Set the space of about 0.5mm at the bottom dead point position between the “upper die (6)” and the “stopper (5).”

“Note” Please note that there is a case of the tool damage when the bottom dead point of the main body of the hand press is adjusted low too much.

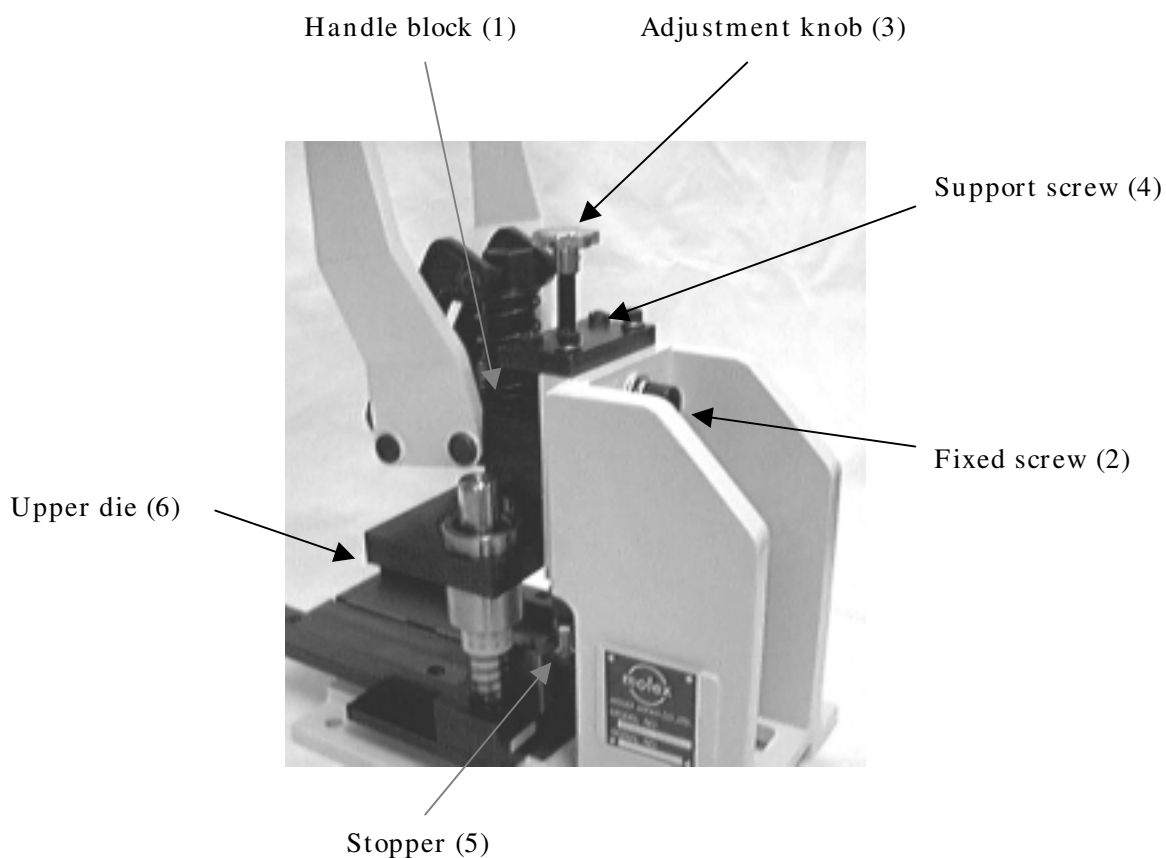

7. Parts List

7.1. Slide Table Development (MFB Manual Terminator)

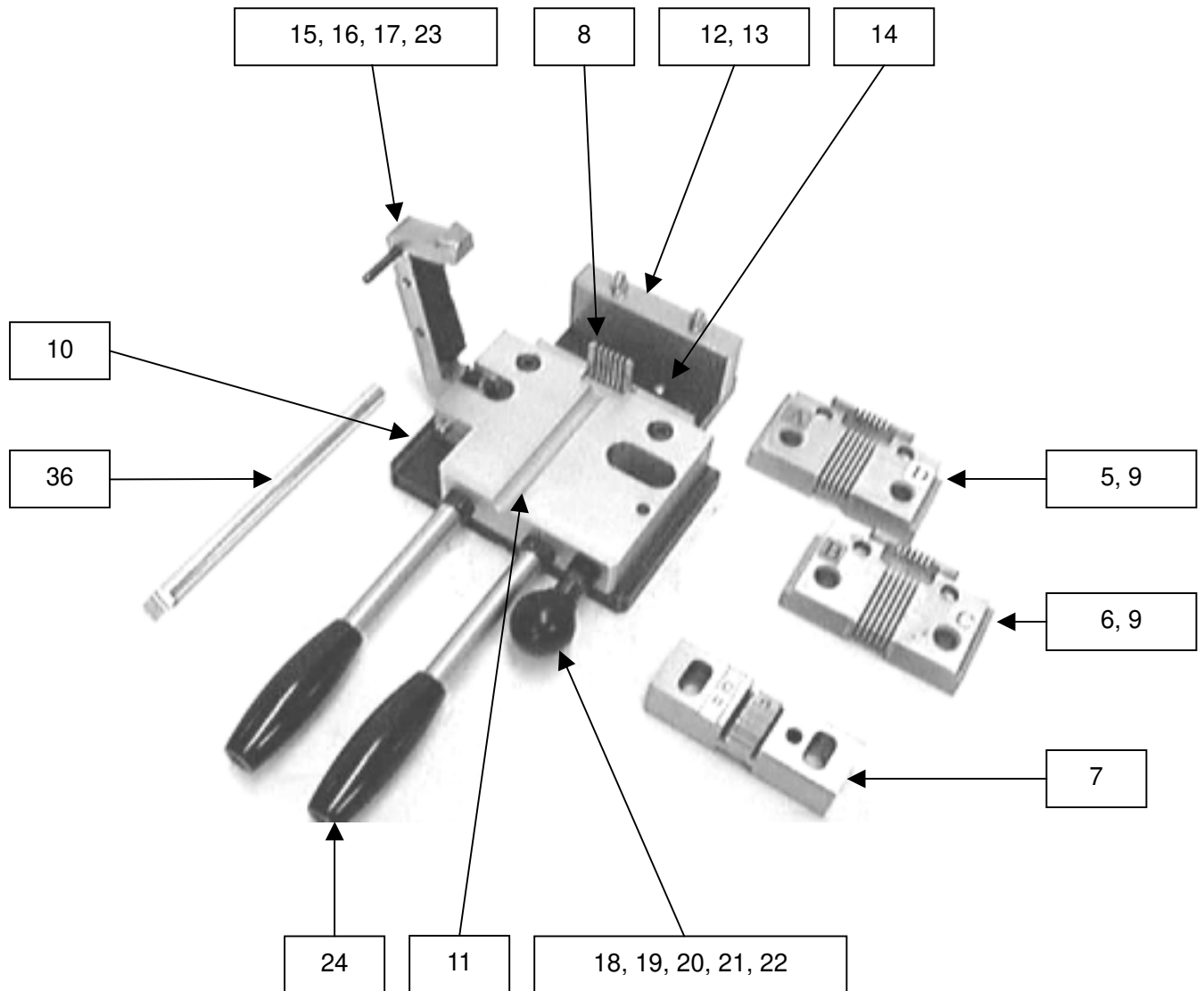

7.2. Termination Tool Development (MFB Manual Terminator)

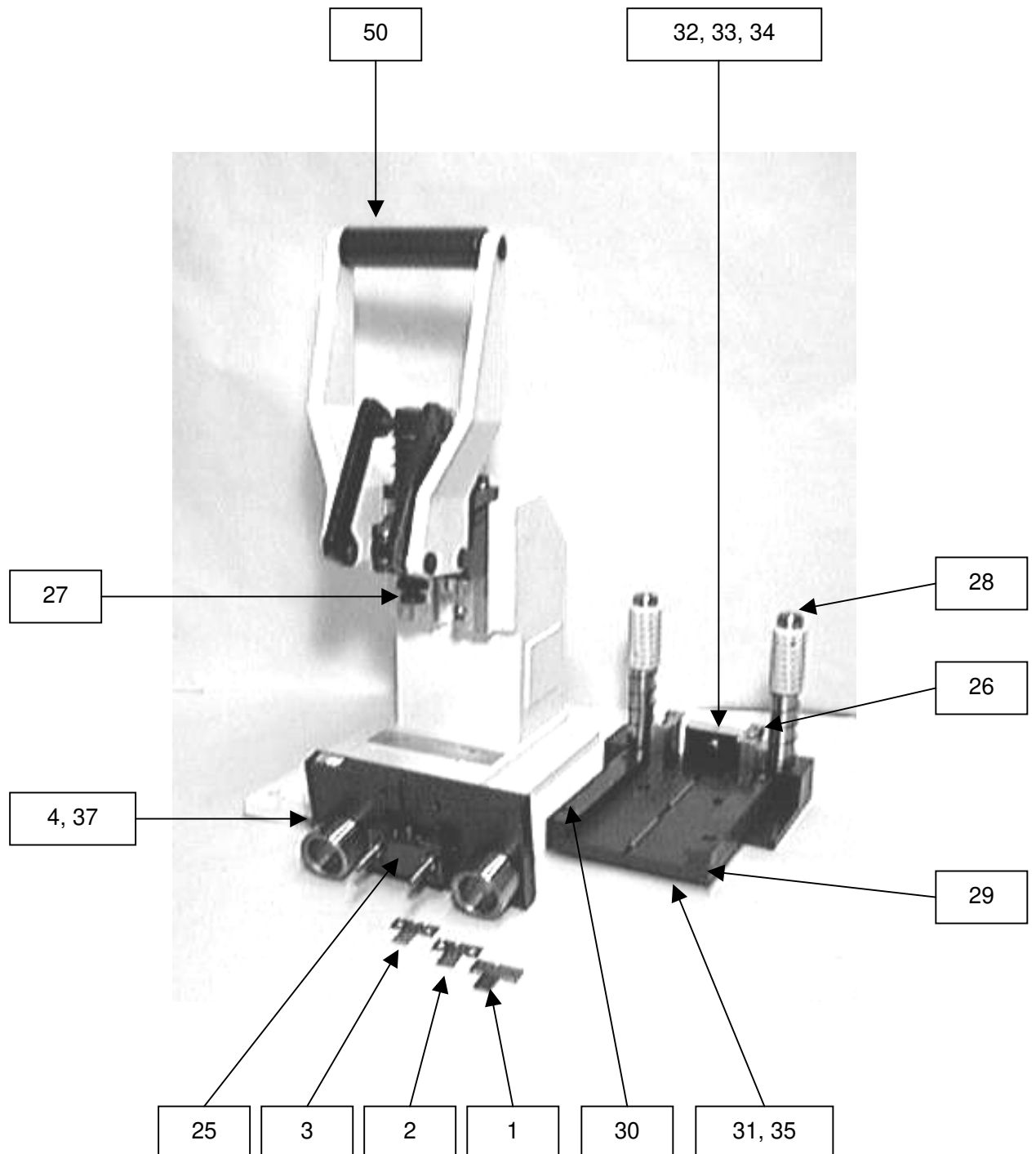

7.3. Parts List

[Applicable Tool] 57831-5000: MFB Manual Terminator

No.	Parts No.	Parts Name	Q'ty	Maker: Parts No.
	[Perishable Parts]			
1	57831-2001	IDT Punch (Outside)	2	
2	57831-2002	Crimp Punch	2	
3	57831-2003	IDT Punch (Cutting)	2	
4	57831-2004	Pilot	4	
5	57831-2005	A/D-row Cut-die	1	
6	57831-2006	B/C-row Cut-die	1	
7	57831-2007	Connector Holder	1	
8	57831-2008	Wire Guide Comb	1	
	[Standard Parts]			
9	57831-1009	Stop Comb	2	
10	57831-1010	Slide Base	1	
11	57831-1011	Cable Clamp Base	1	
12	57831-1012	Guide Pin Block	1	
13	57831-1013	Guide Pin	2	
14	57831-1014	Post	1	
15	57831-1015	Cable Clamp Lever	1	
16	57831-1016	Temporary Stop Comb	1	
17	57831-1017	Spring, Cable Clamp	1	
18	57831-1018	Latch Finger	1	
19	57831-1019	Spring, Latch Finger	1	
20	57831-1020	Nut, Latch Finger	1	
21	57831-1021	Spacer, Latch Finger	1	
22	57831-1022	Release Knob	1	MISUMI: PC20x5
23	57831-1023	Dowel Pin	1	Phi4x30L
24	57831-1024	Knob	2	MISUMI: LOG6-100
25	57831-1025	Punch Set Block	2	
26	57831-1026	Cut-die Guide	4	
27	57831-1027	Shank	2	
28	57831-1028	Die-set	2	
29	57831-1029	Guide Rail-R	2	
30	57831-1030	Guide Rail-L	2	
31	57831-1031	Guide Base	2	
32	57831-1032	Stopper Block	2	
33	57831-1033	Stopper Bolt	2	MISUMI: UTS5-20
34	57831-1034	Stopper Bolt	2	MISUMI: UTS6-40
35	57831-1035	Guide Key	4	MISUMI: KES6-50
36	57831-1036	Wire Trimming Tool	1	
37	57844-1020	Shank Plate	2	
50	57823-5300	Hand Press ASS'Y	3	STE: FX-004

8. MFB Manual Terminator Startup Checklist

[Applicable Tool] 57831-5000: MFB Manual Terminator

“Note” Please check the following matter before the commencement of work, and start operation after checking those without a problem. Please record check results simultaneously.

No.	Check point	Standard	Method/equipment	Record	Startup	Monthly
1	Termination depth	A = 0.83 +0.15/-0mm	Dial gauge for termination depth	Data	O	
		B = 2.83 +0.15/-0mm				
		C = 2.63 +0.15/-0mm				
		D = 0.63 +0.15/-0mm				
2	Wire protruding length	0.8mm or more from the IDT terminal	Magnifying glass	Data	O	
3	Shear drop of conductor	Don't exceed the outside diameter of insulation.	Magnifying glass	-	O	
4	Connector	No damage and no remarkable scratch	Visual check	-	O	
5	Wire insulation	No crack and no remarkable crash	Visual check	-	O	
6	Cut-die	No damage	Visual check	-	O	
7	Wire guide comb	No damage	Visual check	-	O	
[Monthly Checking]						
8	Ram and die-set shaft	No dry up	Grease supplying	-	-	O

