

THESE DRAWINGS ARE THE PROPERTY OF QUALTEK ELECTRONICS AND NOT TO BE REPRODUCED FOR OR COMMUNICATED TO A THIRD PARTY WITHOUT THE EXPRESS WRITTEN PERMISSION OF AN OFFICER OF QUALTEK ELECTRONICS.

REVISION			
REV.	DESCRIPTION	DATE	APPROVED

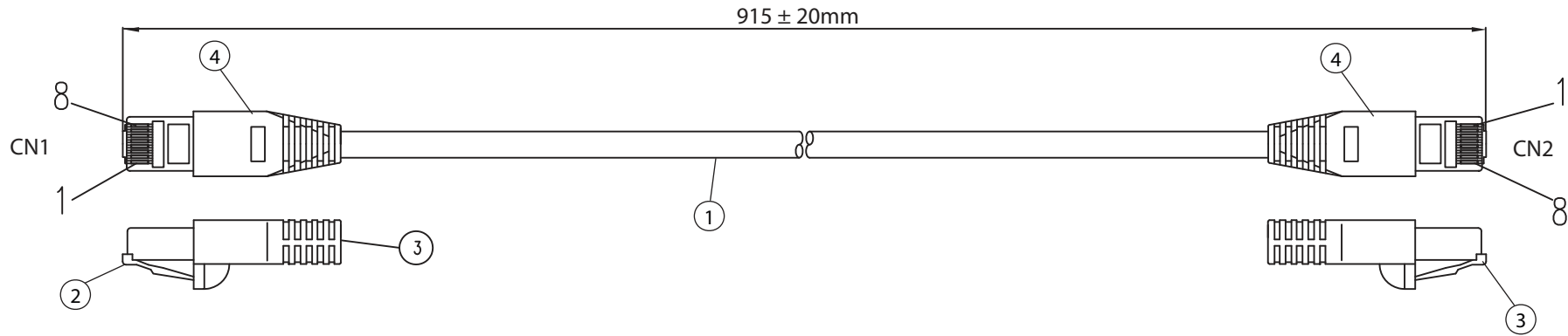

CONNECTION

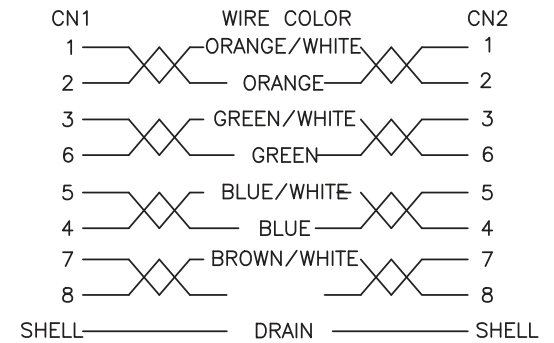

NOTES:

- CABLE: UL 2835 STP CAT-5e 350MHz
24AWG*4PR+AE
OUTER JACKET: WHITE OD: 5.5 ± 0.2mm
- CONNECTOR: RJ45 8P8C
CONTACT PHOSPHOR BRONZE
GOLD PLATED G/F
SHELL NICKEL PLATED
- CONNECTOR: RJ45 8P8C
CONTACT PHOSPHOR BRONZE
GOLD PLATED G/F
SHELL NICKEL PLATED
- PVC MOLDED HOOD: COLOR WHITE
- ELECTRICAL TEST:
<1>.100% OPEN SHORT & MISS WIRE TEST
<2>.INSULATION RESISTANCE: DC300V 20M ohm MIN.
<3>.CONDUCTOR RESISTANCE: 2 ohm MAX.

CONTROLLED

Dim range (mm)	Tolerance +/- (mm)	Qualtek Electronics Corp. WCI DIVISION		
		Part Number: 1221021-03	RoHS Compliant	
0-1	0.15	Description: 8P8C - 8P8C		
1-6	0.20	RFQ# 2505H	UNIT: mm	
6-18	0.30		Drawn / Date	Checked / Date
18-50	0.50	R. Nuti 07-15-13	07-15-13	LY / 07-15-13
50-120	0.70			
120-250	0.90			
250-500	1.20			