

DRAWING MADE IN THIRD ANGLE PROJECTION
 THIS DRAWING IS UNCLASSIFIED
 RELEASED FOR PUBLICATION
 BY AMP INCORPORATED. ALL INTERNATIONAL RIGHTS RESERVED.

REV	DATE	DESCRIPTION	BY	CHK
0	12-13-89	RELEASED, HAS 63-4820-39	JMN	
A	01-14-90	REV PER ECN DF-2961		ETG
B	03-22-90	REV PER ECN DF-2957		ETG
C	08-21-90	REV PER ECN DF-3520		ETG

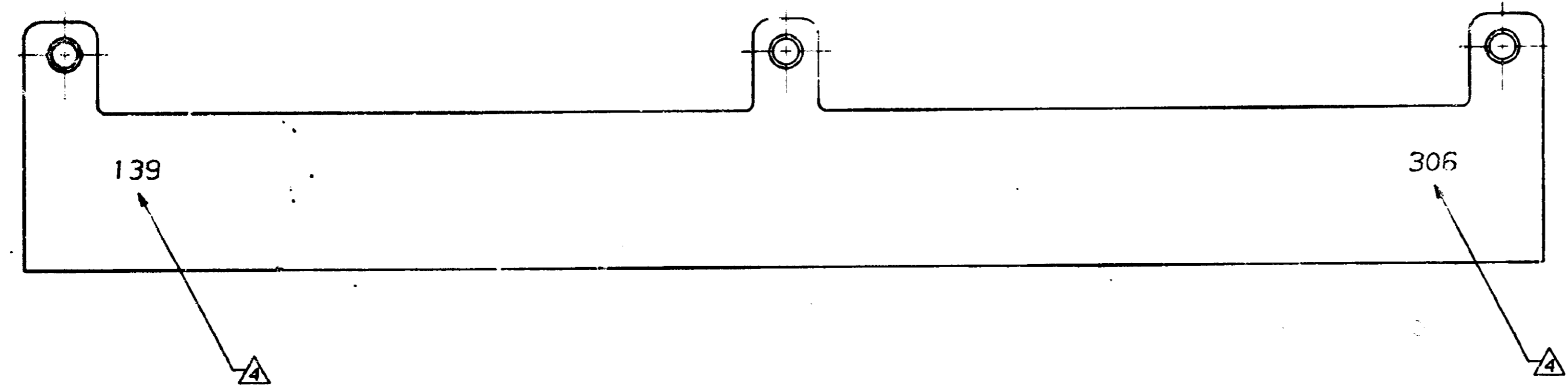

- 1 MATERIAL: ALUMINUM, ASTM B 221-ALLOY 6061-T6.
- 2 FINISH: CHROMATE CONVERSION PER MIL-C-5541, CLASS 3.
- 3 INK STAMP AMP, AMP P/N, DATE CODE AND FSCM NO. IN THIS AREA PER MIL-STD-1285 AND MIL-STD-202, METHOD 215.
- 4 INK STAMP NUMBERS "139" AND "306" IN AREA SHOWN PER MIL-STD-1285 AND MIL-STD-202, METHOD 215.

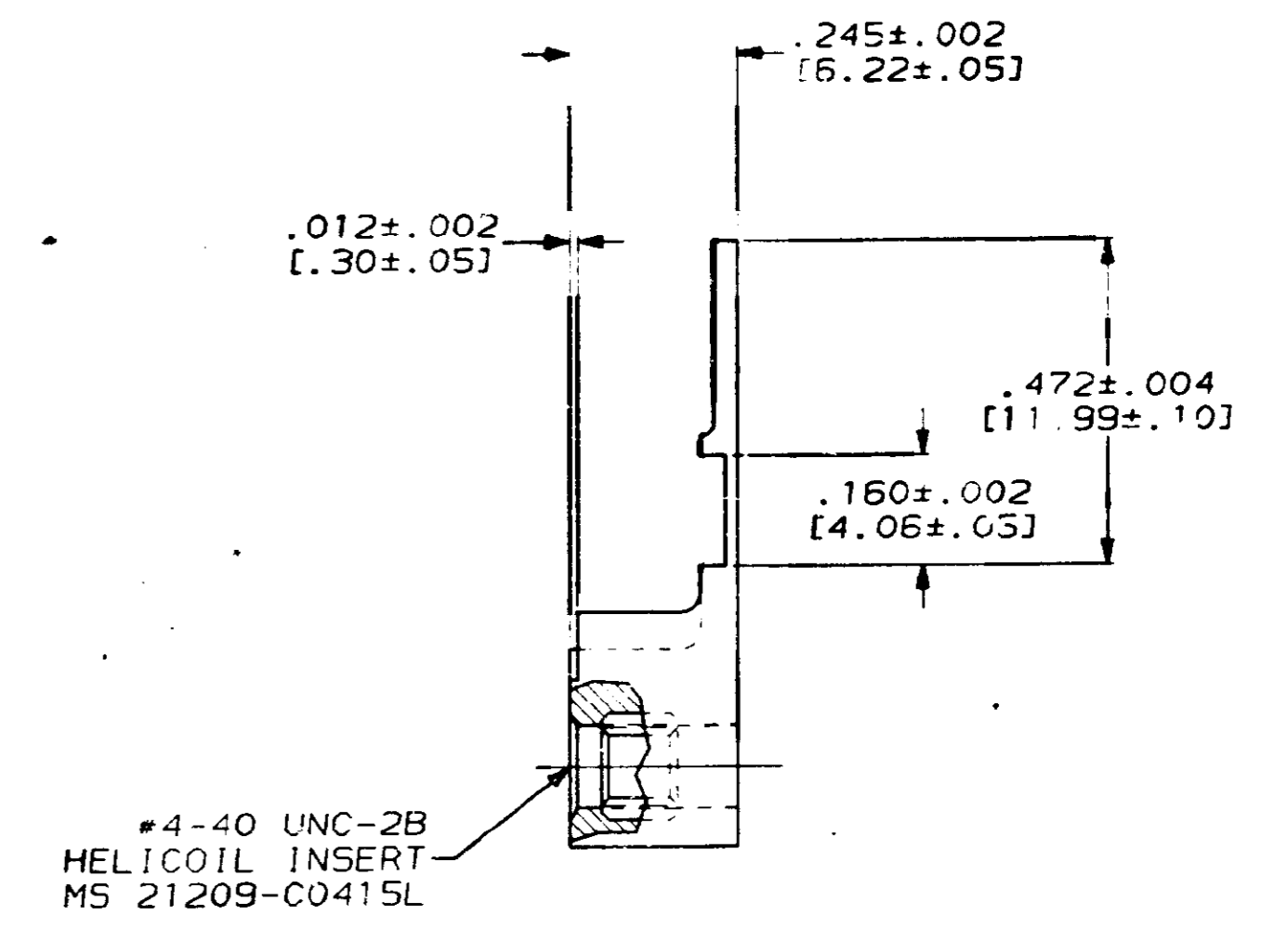
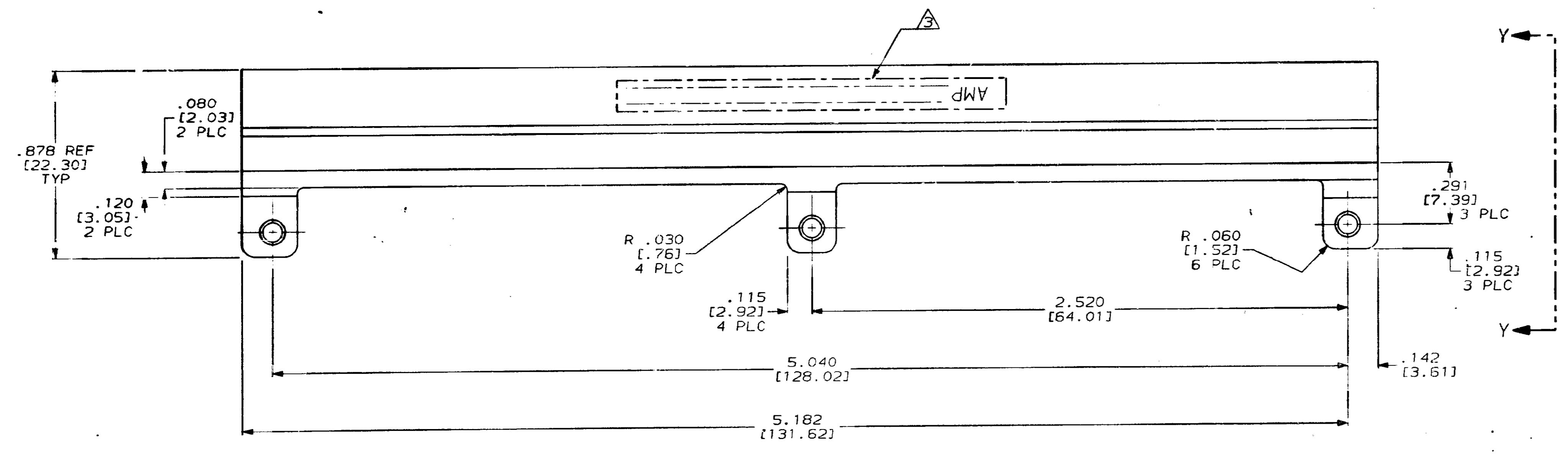
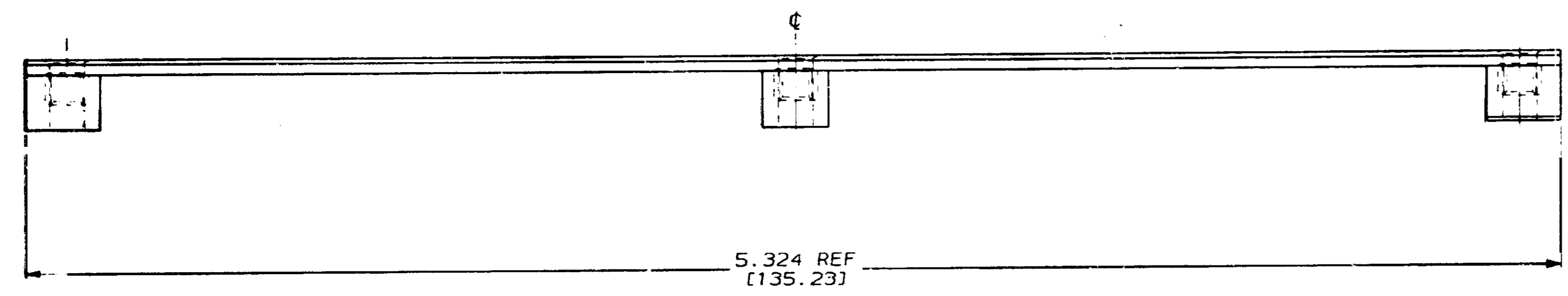

VIEW Y-Y
SCALE 4:1

447006-1
PART NO

DR 12-13-89 B.W. BLAIR CHK 01-02-90 J.M. NORTON APPD 01-02-90 J.M. NORTON APPD 01-03-90 D.E. SMITH PRODUCT SPEC -		AMP AMP INCORPORATED Harrisburg, Pa. 17105	
DC NOT SCALE PRINT. UNLESS SPECIFIED DIMENSIONS IN INCHES [mm] TOLERANCES ON: 2 PLC DEC ± - 3 PLC DEC ± .005 [.13] ANGLES ± - MATERIAL 1		NAME SHELL ASSEMBLY, B-SIDE, HDI-6ROW	
FINISH 2		SIZE D FSCM NO 00779	DRAWING NO 447006
WEIGHT -		SCALE 3:1	SHEET 1 OF 1

CUSTOMER DRAWING