

4

3

2

1

THIS DRAWING IS UNPUBLISHED. RELEASED FOR PUBLICATION  
© COPYRIGHT ALL RIGHTS RESERVED.

LOC	DIST	REVISIONS			
P	LTR	DESCRIPTION	DATE	DWN	APVD
	A1	ECR-16-011296	03OCT2016	GK	SD

# REPLACED BY OCEAN STYLE APPLICATOR PART NUMBER 2836377-2

FOR REPLACEMENT PARTS FOR APPLICATOR 1852642  
REFER TO ADDITIONAL PAGE(S). SPARE PARTS KIT (IF LISTED)  
WILL REMAIN AVAILABLE.

THE REPLACEMENT OCEAN STYLE APPLICATOR HAS THE  
SAME TERMINATOR/PRESS INTERFACE AS APPLICATOR  
1852642

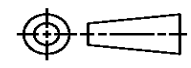
THIS DRAWING IS A CONTROLLED DOCUMENT.		DWN	GOPALAKRISHNA HV		 <b>TE Connectivity</b>
DIMENSIONS:		CHK	GOPALAKRISHNA HV		
		TOLERANCES UNLESS OTHERWISE SPECIFIED:		NAME	
		0 PLC ±		SIDE FEED HDM APPLICATOR	
		1 PLC ±		PRODUCT SPEC	
		2 PLC ±		APPLICATION SPEC	
		3 PLC ±		SIZE	CAGE CODE
		4 PLC ±		DRAWING NO	
		ANGLES ±		C- 1852642	
MATERIAL		FINISH		RESTRICTED TO	
				WEIGHT	
				CUSTOMER DRAWING	
				SCALE	SHEET 1 OF 2
				REV A1	

PART NUMBER	REV	FIRST USED	POWER UNIT	FEED TYPE	DESCRIPTION
1852642-1	A	122500-1	LEADMAKER	AIR FEED	CUTS CARRIER
1852642-2	A	565435-5	BENCH MODEL K	AIR FEED	CUTS CARRIER
1852642-3	A	354500-1	BENCH MODEL G	AIR FEED	CUTS CARRIER
1852642-6	A	122500-1	LEADMAKER	AIR FEED	CONTINUOUS CARRIER
7-1852642-7	A	-	-	-	SPARE PARTS

- △ RECOMMENDED SPARE PARTS
- △ GREASE LIGHTLY
- △ GUARD MUST BE IN PLACE WHEN OPERATING APPLICATOR IN A BENCH MACHINE
- △ CUT TO LENGTH AT ASSEMBLY.

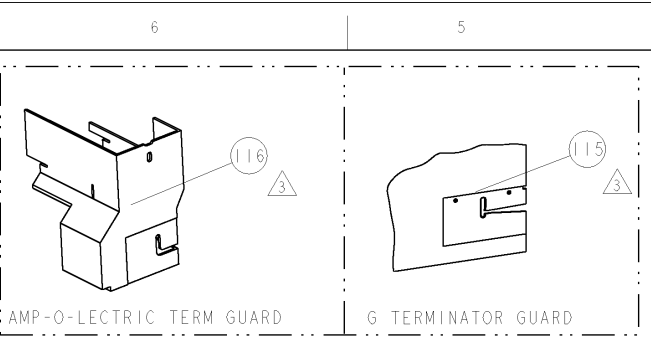

TERMINAL NAME: 1.25mm (.049) PITCH PANELMATE WIRE-TO-BOARD			
TE P/N	MOLEX P/N	MOLEX TERMINAL - MOLEX CRIMP SPECS	
1949618	50641-8041		
		PAD LTR	CRIMP HEIGHT
		A	0.645mm±.025/- .025 [.025+.001/- .001]
		B	0.605mm±.025/- .025 [.024+.001/- .001]
		C	0.575mm±.025/- .025 [.023+.001/- .001]
		D	-
		CRIMP	SIZE
		WIRE	0.80mm [.031]
		INSUL	0.80mm [.031]
		FEED	4.800
		APPLICATOR INSTRUCTIONS	408-8040
		SET UP GAGE	458637-1
WIRE STRIP LENGTH	TECHN. APPL. SPEC	FEED	APPLICATOR INSTRUCTIONS
1.300-1.700	NONE	4.800	408-8040

REVISONS		DATE	BY	APPD
A	RELEASED	02MAY2008	RK	GB

QTY	REF	DESCRIPTION	ITEM NO
-	-	692655-6 AIR FEED VALVE ASSEMBLY	118
-	1	461062-1 FEED FINGER ASSEMBLY	117
-	-	455749-1 GUARD WINDOW	116
-	-	679532-1 INSERT, GUARD	115
-	1	690603-1 SPRING ASSIST AMP-O-MATOR APPLICATOR	112
-	1	3-21001-5 SCR, SKT HD CAP 3/8-16 X 1.000	111
-	1	459610-1 MOUNT, FEED BRACKET	110
-	1	21024-8 WASHER, SPRG LOCK, REG 3/8	109
-	1	692655-7 AIR FEED VALVE ASSEMBLY	108
-	-	24024-2 VALVE, SHUT OFF	106
-	-	692655-5 AIR FEED VALVE ASSEMBLY	105
-	1	461065-1 ASSEMBLY, AIR FEED	104
-	2	3-21000-9 SCR, SKT HD CAP 10-32 X 1.000	103
-	1	2-21008-9 SCR, SET, SELF LOCKING 1/4-20 X .250	97
-	1	1633015-1 FRONT STRIP GUIDE	96
-	2	1-21000-3 SCR, SKT HD CAP 4-40 X .250	95
-	1	690191-5 PLUG, NYLON	94
-	1	1633031-1 ROD, THREADED	93
-	1	1633020-1 FINE ADJUST SCREW BLOCK	92
-	1	318563-1 GUARD, FRONT CHIP	89
-	1	1-455888-7 SPACER, CRIMPER	82
-	1	4088040 SF APPL INST 408-8040	72
-	1	217238-1 GENERAL INSTRUCTION PKG	71
-	2	21024-2 WASHER, SPRG LOCK, REG NO 4	68
-	1	461264-1 PLATE, IDENTIFICATION	67
-	2	21017-2 SCREW, DRIVE	66
-	1	986950-1 WASHER, FLAT PRECISION	64
-	1	21009-2 SCR, SET, SELF LOCKING 1/4-20 X .250	63
-	1	23030-1 SCR, SKT HD CAP 6-32 X .25	62
-	2	5-21006-6 SCR, SET, CUP POINT 10-32 X .750	61
-	1	22733-8 SCR, BHSC, SELF-LOCKING, 8-32 X .375	60
-	1	2-22603-0 SCR, HEX HD CAP 8-32 X .312	59
-	1	3-694433-2 FEED PAWL	56
-	6	2-21002-2 SCR, BTN SKT HD CAP 8-32 X .500	54
-	2	2-21000-5 SCR, SKT HD CAP 8-32 X .250	53
-	1	1633399-2 APPL., BASIC AIR FEED SUB ASSY	46
-	1	690191-1 PLUG, NYLON	45
-	1	1-455673-1 RAM, SIDE FEED	44
-	1	690125-1 SHIM SUB-ASSY	43
-	1	690124-4 WASHER, RAM (.135)	42
-	1	7-21002-9 SCR, BTN SKT HD CAP 5/16-24 X 1.00	41
-	1	23241-6 BALL, STEEL	40
-	1	690170-1 SPRING, COMPRESSION	39
-	1	690142-6 DISC, INSULATION	38
-	1	354777-1 WIRE DISC, ASSEMBLY	37
-	1	22480-5 SPRING, COMPRESSION	36
-	1	690212-1 POST, RAM	35
-	1	1633663-1 TERMINAL SUPPORT	34
-	2	2-21002-1 SCR, BTN SKT HD CAP 8-32 X .375	33
-	3	21024-5 WASHER, SPRG LOCK, REG NO 10	32
-	1	3-21000-4 SCR, SKT HD CAP 10-32 X .375	31
-	1	1633016-1 PLATE, STRIP GUIDE	29
-	1	455888-4 SPACER, CRIMPER	28
-	2	1-22284-0 SPRING, COMPRESSION	27
-	1	356835-1 LEVER, DRAG RELEASE	26
-	1	679754-2 STOCK DRAG ASSEMBLY	25
-	1	1633013-4 STRIP GUIDE, REAR	24
-	1	21989-8 SCR, SKT HD SHLDR 3/16 DIA X .250	23
-	1	2-21000-7 SCR, SKT HD CAP 8-32 X .500	21
-	4	21024-4 WASHER, SPRG LOCK, REG NO 8	20
-	1	691353-2 STRIPPER	19
-	1	4-690518-5 HOLD DOWN, TERMINAL	18
-	1	679625-1 SHEAR HOLDER, FRONT (NO CUT)	13
-	1	3-22280-3 SPRING, COMPRESSION	12
-	1	690461-1 STOP, SHEAR	11
-	1	690459-1 SHEAR HOLDER, FRONT	10
-	1	462006-1 FLOATING SHEAR, FRONT	9
-	1	1-1633544-7 ANVIL, COMBINATION	8
-	1	854772-9 DEPRESSOR, SHEAR	5
-	1	2-238011-3 BLOCK, CRIMPER SPACER	4
-	1	2-1633511-6 CRIMPER, INSULATION F	3
-	-	-	2
-	1	1-1333281-8 CRIMPER, WIRE PREMIUM	1

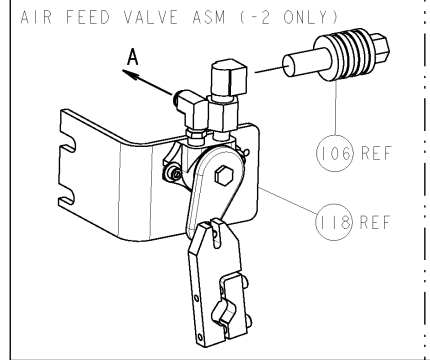
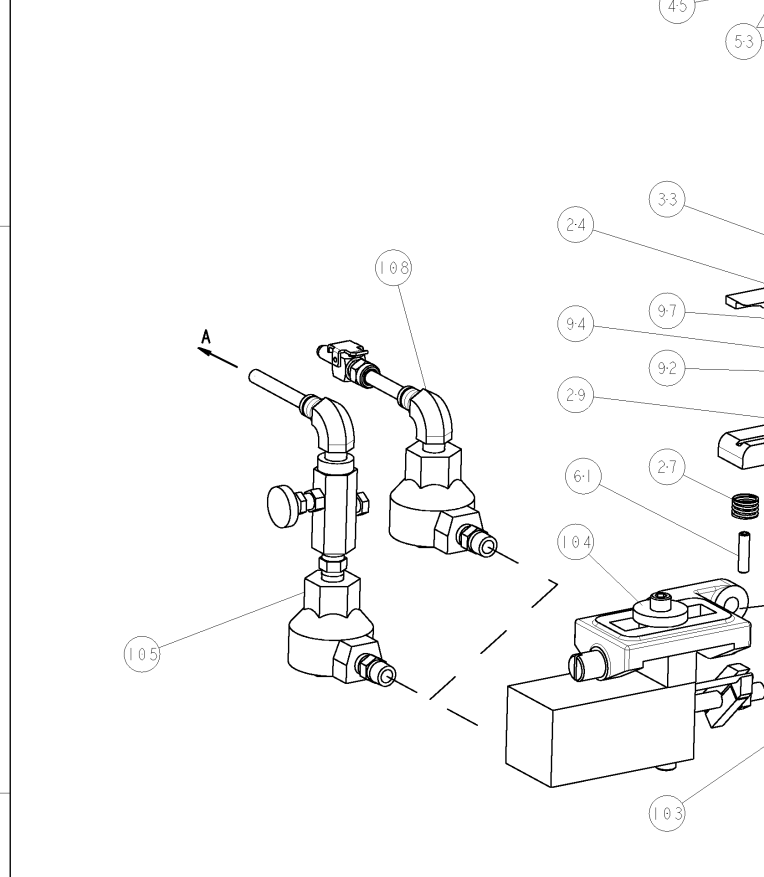
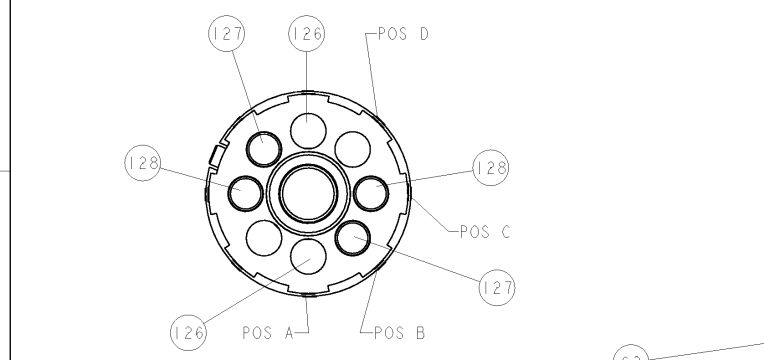

FEED TRACK POSITION GUIDE BY INS. BARREL

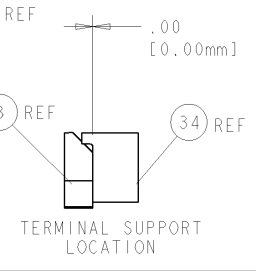

QTY	REF	DESCRIPTION	ITEM NO					
-	1	21028-2 PIN, SLOTTED SPRING .062 X .250	220					
-	1	5-547505-2 SPRING, COMPRESSION	219					
-	1	854769-4 HOLDER, INS	218					
-	2	1-354779-3 PIN, WIRE DISC, .3055	128					
-	2	354779-9 PIN, WIRE DISC, .3035	127					
-	2	354779-6 PIN, WIRE DISC, .3020	126					
-77	-6	-3	-2	-1	U/M	PART NO	DESCRIPTION	ITEM NO

DIMENSIONS:		TOLERANCES UNLESS OTHERWISE SPECIFIED:	
INCHES	PLC	+	
	1 PLC	±	
	2 PLC	±0.01	
	3 PLC	±0.001	
	4 PLC	±0.0001	