

## Easy to Use Power Bank Solution (EZPBS™) Integrated Chip with Two Ports Output

### General Description

The RT9480 is a high integration and easy to use power solution for Li-ion power bank and other powered handheld applications. We call it EZPBS™ (Easy to Use Power Bank Solution). This single chip includes a linear charger, a synchronous Boost with dual output load management and a torch function support. The battery volume and the state of charging and discharging can be indicated by 4LEDs. The RT9480 is available in the WQFN-24L 4x4 package.

### Applications

- Li-ion Power Bank

### Ordering Information

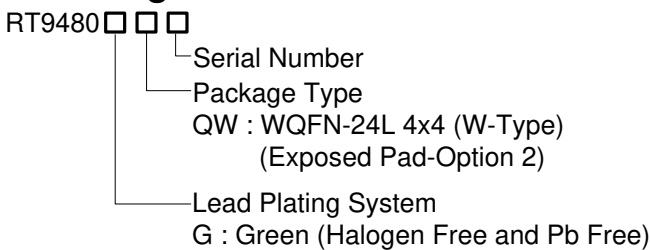

Note :

Richtek products are :

- ▶ RoHS compliant and compatible with the current requirements of IPC/JEDEC J-STD-020.
- ▶ Suitable for use in SnPb or Pb-free soldering processes.

### Features

#### EZPBS™ (Easy to Use Power Bank Solution)

- Compact BOM Elements with EZPBS™ Single Chip
- Protection Functions (OTP, OVP, OCP, VBUS and Output Short Protection)
- Support Charging and Discharging at the same time by Smart Algorithm

#### Charger

- One Linear Charger up to 1.2A
- DPM Function (Dynamic Power Management)
- Thermal Regulation
- Auto-Recharge
- Support JEITA Function

#### USB Output

- Support Dual USB Output
- Auto and Button Control
- Sync-Boost Total Output Current up to 2.5A  
▶ Peak Efficiency 97%

#### Battery State of Charge (SOC) Indicator

- Battery SOC Detection
- Support NTC for Battery Temperature Sensing
- 4LEDs for Battery SOC Display

#### Other Functions

- Torch Functions

### Simplified Application Circuit

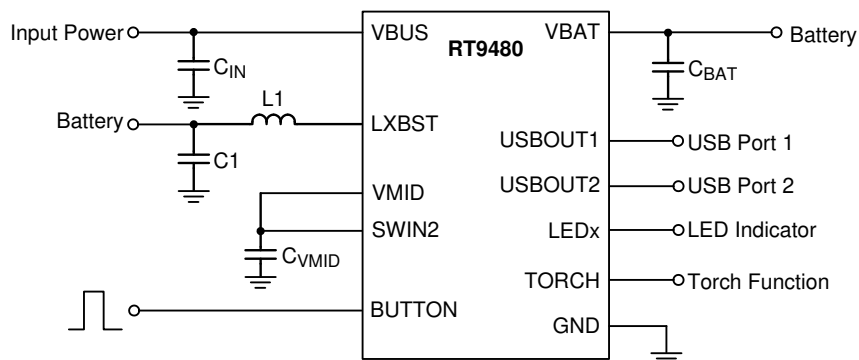

## Pin Configuration

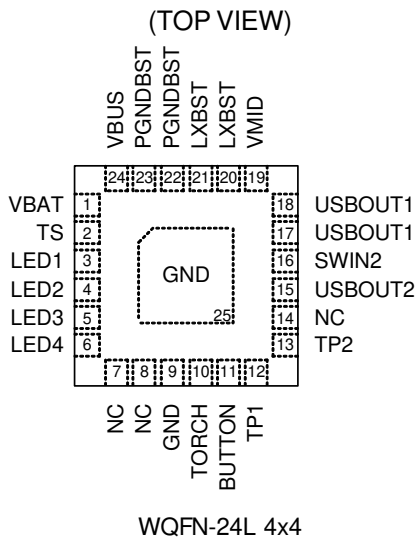

## Marking Information

For marking information, contact our sales representative directly or through a Richtek distributor located in your area.

## Product Name List

Serial Number	Product Name	Auto/Button	SOC LED Number	Programmable	Battery Regulation	Time Out of USBOUT Detach
	RT9480GQW	Button	4LEDs	Disable	4.2V	12 Hours
AA01	RT9480GQW-AA01	Auto	4LEDs	Disable	4.2V	3sec
AA02	RT9480GQW-AA02	Button	4LEDs	Disable	4.35V	12 Hours
AA03	RT9480GQW-AA03	Button	4LEDs	Disable	4.2V	3sec

**Functional Pin Description**

Pin No.	Pin Name	Pin Function
1	VBAT	Battery charge current output.
2	TS	Battery temperature sense setting.
3	LED1	Current sink output for LED1.
4	LED2	Current sink output for LED2.
5	LED3	Current sink output for LED3.
6	LED4	Current sink output for LED4.
7, 8, 14	NC	No internal connection.
9, 25 (Exposed Pad)	GND	Ground. The exposed pad must be soldered to a large PCB and connected to GND for maximum power dissipation.
10	TORCH	Current sink output for torch LED function. Open drain output
11	BUTTON	Button control input for mode change.
12	TP1	Connected to GND.
13	TP2	Connected to GND.
15	USBOUT2	USB-2 power output.
16	SWIN2	USB-2 power input.
17, 18	USBOUT1	USB-1 power output.
19	VMID	Boost output.
20, 21	LXBST	Boost Switch output.
22, 23	PGNDBST	Boost power GND.
24	VBUS	VBUS power supply.

Functional Block Diagram

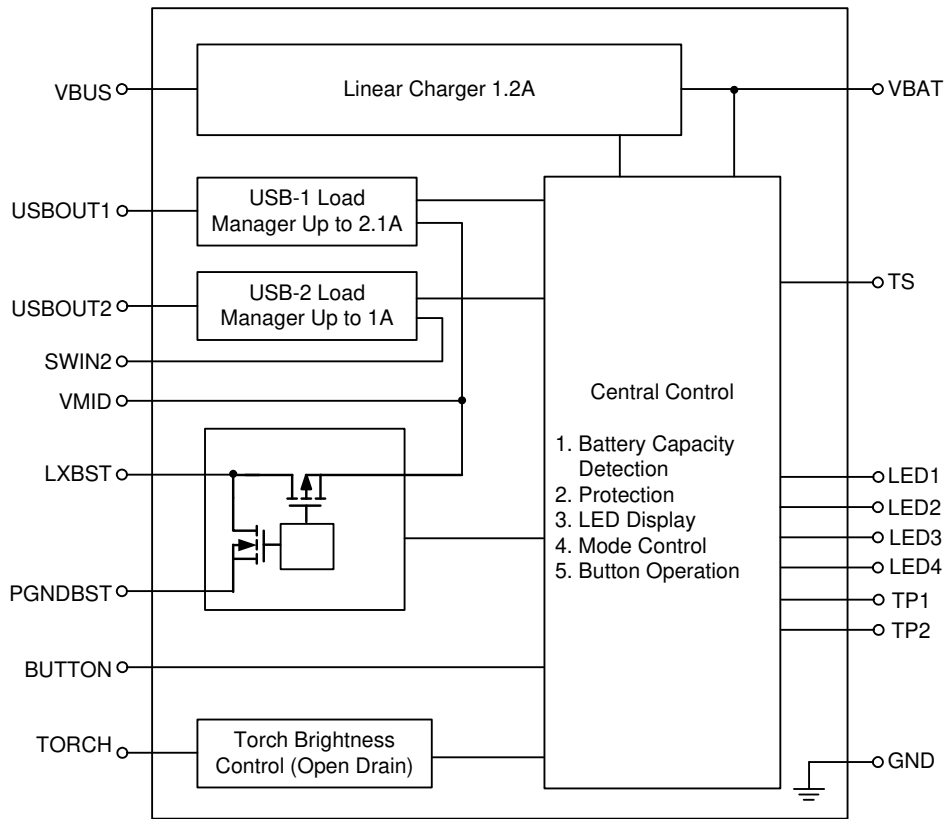

## Operation

The RT9480 is a high integrated IC for Li-Ion battery power bank. It includes a linear charger 1.2A, a synchronous Boost 5.1V, two output load management, LED indicator and torch function.

### Change Current

Base on thermal regulation function, the charging current can support up to 1.2A.

### VBUS OVP

If the input voltage (VBUS) is higher than the threshold voltage  $V_{OVP}$ , the internal OVP signal will go high and the charger will stop charging until VIN is below  $V_{OVP} - \Delta V_{OVP}$ .

### VMID OVP

If the internal voltage (VMID) is higher than the threshold voltage  $V_{OVP}$ , the internal OVP signal will go high and the charger will stop charging until VMID is below  $V_{OVP} - \Delta V_{OVP}$ .

### OCP

The converter senses the current signal when the high-side P-MOSFET turns on. As a result, The OCP is cycle by-cycle current limitation. If the OCP occurs, the converter holds off the next on pulse until inductor current drops below the OCP limit.

### OTP

The converter has an over-temperature protection. When the junction temperature is higher than the thermal shutdown rising threshold, the system will be latched and the output voltage will no longer be regulated until the junction temperature drops under the falling threshold.

### Output Short Protection

When output short to ground, the system will be latched and the output voltage will no longer be regulated until power reset.

### CC/CV/TR Multi Loop Controller

There are constant current loop, constant voltage loop and thermal regulation loop to control the charging current.

### Too Hot or Too Cold

The temperature sense input TS pin can be connected a thermistor to determine whether the battery is too hot or too cold for charging operation. If the battery's temperature is out of range, charging is paused until it re-enters the valid range.

## Absolute Maximum Ratings (Note 1)

- Supply Voltage, VBAT ----- -0.3V to 6V
- Supply Voltage, VBUS ----- -0.3V to 10V
- Supply Voltage USBOUT1, USBOUT2 Pulse (100µs) ----- -0.3V to 10V
- LED Output Voltage, LED1, LED2, LED3, LED4 ----- -0.3V to 10V
- TORCH ----- -0.3V to 10V
- Other Pins ----- -0.3V to 6V
- Power Dissipation, P<sub>D</sub> @ T<sub>A</sub> = 25°C
  - WQFN-24L 4x4 ----- 3.57W
- Package Thermal Resistance (Note 2)
  - WQFN-24L 4x4, θ<sub>JA</sub> ----- 28°C/W
  - WQFN-24L 4x4, θ<sub>JC</sub> ----- 7.1°C/W
- Junction Temperature Range ----- 150°C
- Lead Temperature (Soldering, 10 sec.) ----- 260°C
- Storage Temperature Range ----- -65°C to 150°C
- ESD Susceptibility (Note 3)
  - HBM (Human Body Model) ----- 2kV
  - MM (Machine Model) ----- 200V

## Recommended Operating Conditions (Note 4)

- Supply Input Voltage, VBAT, VBUS ----- 2.8V to 5.5V
- Junction Temperature Range ----- -40°C to 125°C
- Ambient Temperature Range ----- -40°C to 85°C

## Electrical Characteristics

### TOP Unit Electrical Characteristics

(V<sub>BUS</sub> = 5V, V<sub>BAT</sub> = 3.7V, T<sub>A</sub> = 25°C, unless otherwise specified)

Parameter	Symbol	Test Conditions	Min	Typ	Max	Unit	
<b>Supply Input</b>							
Battery Quiescent Current for Standby	I <sub>BAT_sdy</sub>	No VBUS, Boost on, Indicator Off.	Button Mode	--	30	--	µA

**Charger Unit Electrical Characteristics**

(V<sub>BUS</sub> = 5V, V<sub>BAT</sub> = 3.7V, T<sub>A</sub> = 25°C, unless otherwise specified)

Parameter	Symbol	Test Conditions	Min	Typ	Max	Unit
<b>Supply Input</b>						
VBUS – VBAT VOS Rising	V <sub>OS_H</sub>		--	100	200	mV
VBUS – VBAT VOS Falling	V <sub>OS_L</sub>		10	50	--	mV
<b>Battery Charger</b>						
VBUS Operating Range	V <sub>BUS_CHG</sub>		4.5	--	5.5	V
VBUS Regulation	DPM	V <sub>DPM</sub> = 4.5V	-5	--	5	%
<b>Voltage Regulation</b>						
VBAT Regulation	V <sub>REG</sub>	T <sub>A</sub> = 0 to 85°C, V <sub>REG</sub> = 4.2V	-1	--	1	%
Re-Charge Threshold	ΔV <sub>RECHG</sub>	V <sub>REG</sub> – Recharge level	--	150	--	mV
VBUS Power FET R <sub>DS(ON)</sub>	R <sub>DS(ON)_chg</sub>	I <sub>BAT</sub> = 1A	--	200	300	mΩ
<b>Current Regulation</b>						
Fast-Charge Current Accuracy	I <sub>CHG</sub>	I <sub>CHG</sub> = 1.2A	-5	--	5	%
Pre-Charge Current Accuracy	I <sub>CHG_Pre</sub>	Ratio of Fast-Charge current	5.5	10	14.5	%
Pre-Charge Threshold	V <sub>pre</sub>	V <sub>BAT</sub> rising	2.35	2.5	2.65	V
Pre-Charge Threshold Hysteresis	ΔV <sub>pre</sub>	V <sub>BAT</sub> falling	120	200	280	mV
<b>Charge Termination Detection</b>						
Termination Current Ratio	I <sub>TERMI</sub>		--	10	--	%
<b>Timer</b>						
Fast-Charge Time Fault	T <sub>F_CC</sub>		--	24	--	hour

**Boost Unit Electrical Characteristics**

(V<sub>BUS</sub> = 5V, V<sub>BAT</sub> = 3.7V, T<sub>A</sub> = 25°C, unless otherwise specified)

Parameter	Symbol	Test Conditions	Min	Typ	Max	Unit
<b>Supply Input</b>						
Output Voltage	V <sub>OUTBST</sub>		--	5.1	--	V
Output Voltage Accuracy	V <sub>OUTBST</sub>		-5	--	5	%
MAX Output Current		As V <sub>BAT</sub> > 3.3V, V <sub>OUT</sub> = 5V	--	2.5	--	A
PFET Peak Current Limit	I <sub>OCP</sub>		6	--	--	A
<b>Power Switch</b>						
Switching Frequency	f <sub>sw</sub>		0.2	0.25	0.3	MHz
<b>Protection</b>						
Over-Voltage Protection	V <sub>MID_OVP</sub>		5.6	5.7	6	V
Over-Voltage Protection Hysteresis	V <sub>MID_OVP_hys</sub>		--	0.2	--	V
Under-Voltage Protection (Short-Circuit Protection)	V <sub>BST_FBUV</sub>		--	3.37	--	V

## Others Electrical Characteristics

(V<sub>BUS</sub> = 5V, V<sub>BAT</sub> = 3.7V, T<sub>A</sub> = 25°C, unless otherwise specified)

Parameter		Symbol	Test Conditions	Min	Typ	Max	Unit
<b>LED</b>							
LED Current Sink		I <sub>LED</sub>		--	0.75	--	mA
<b>Torch</b>							
Open-Drain Low Voltage		V <sub>ODL_T</sub>	I <sub>SINK</sub> = 5mA	--	200	--	mV
<b>Button</b>							
Button Control	Logic-High	V <sub>IH_B</sub>		1.5	--	--	V
	Logic-Low	V <sub>IL_B</sub>		--	--	0.4	V
Press Duty Time	High-Level	T <sub>Press_H</sub>		0.1	--	--	sec
	Low-Level	T <sub>Press_L</sub>		0.1	--	--	sec
<b>Protection</b>							
Charger Thermal Regulation		T <sub>REG</sub>	For charger	--	105	--	°C
Over-Temperature Protect		T <sub>OTP</sub>		--	150	--	°C
Over-Temperature Protect Hysteresis		ΔT <sub>OTP</sub>		--	20	--	°C
VBUS OVP Threshold Voltage		V <sub>OVP</sub>	V <sub>BUS</sub> rising	6.5	6.8	7.1	V
VBUS OVP Threshold Voltage Hysteresis		V <sub>OVP_Hys</sub>	V <sub>BUS</sub> falling	--	200	280	mV
<b>BASE</b>							
VBUS Attached Threshold Voltage		V <sub>BUS_ATT</sub>	V <sub>BUS</sub> rising	3.8	4	4.2	V
VBUS Attached Threshold Voltage Hysteresis		V <sub>BUS_ATT_Hys</sub>	V <sub>BUS</sub> falling	--	200	280	mV

**Note 1.** Stresses beyond those listed “Absolute Maximum Ratings” may cause permanent damage to the device. These are stress ratings only, and functional operation of the device at these or any other conditions beyond those indicated in the operational sections of the specifications is not implied. Exposure to absolute maximum rating conditions may affect device reliability.

**Note 2.** θ<sub>JA</sub> is measured at T<sub>A</sub> = 25°C on a high effective thermal conductivity four-layer test board per JEDEC 51-7.

**Note 3.** Devices are ESD sensitive. Handling precaution is recommended.

**Note 4.** The device is not guaranteed to function outside its operating conditions.



**Typical Application Circuit**

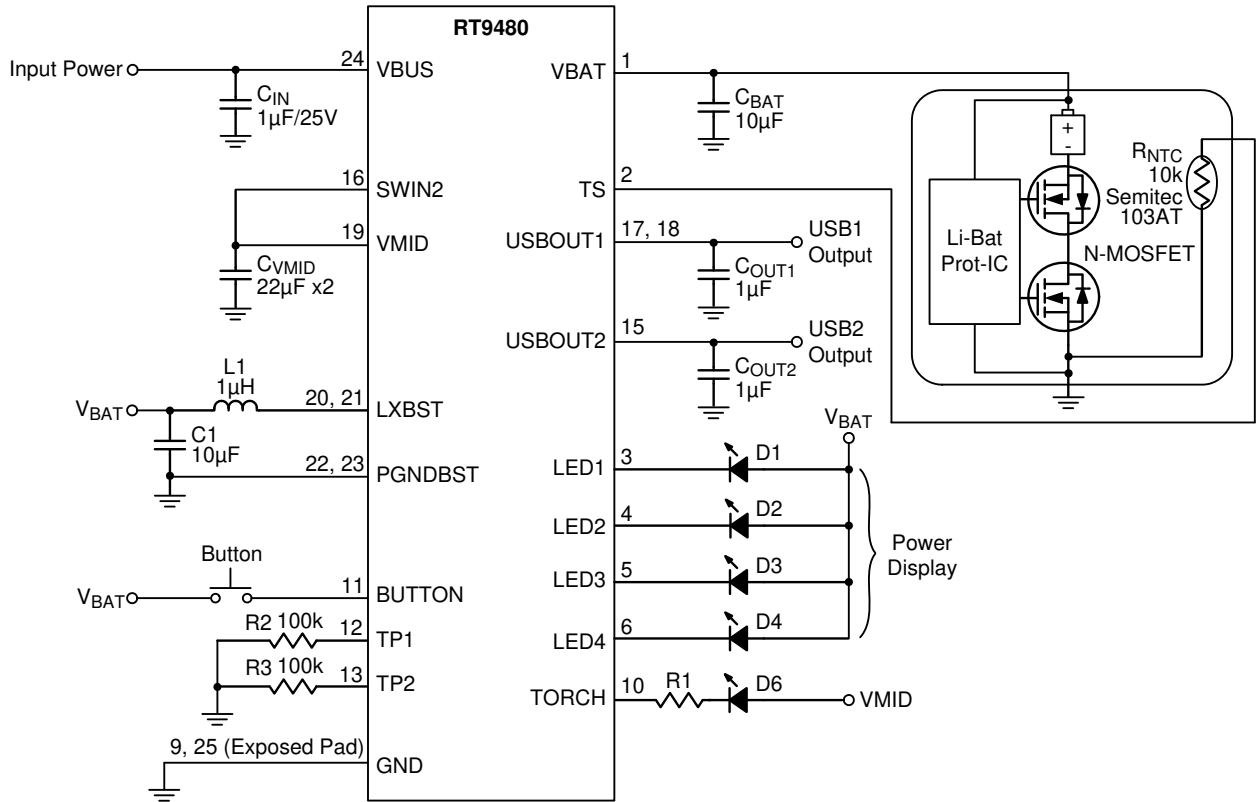

## Typical Operating Characteristics

**USBOUT Efficiency vs. Load Current**

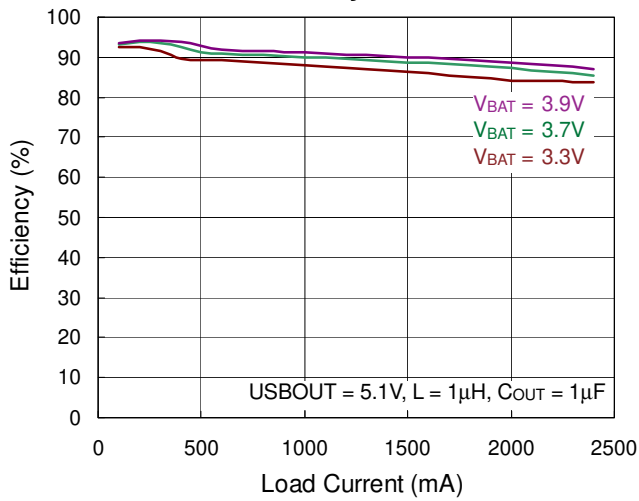

**USBOUT Voltage vs. Load Current**

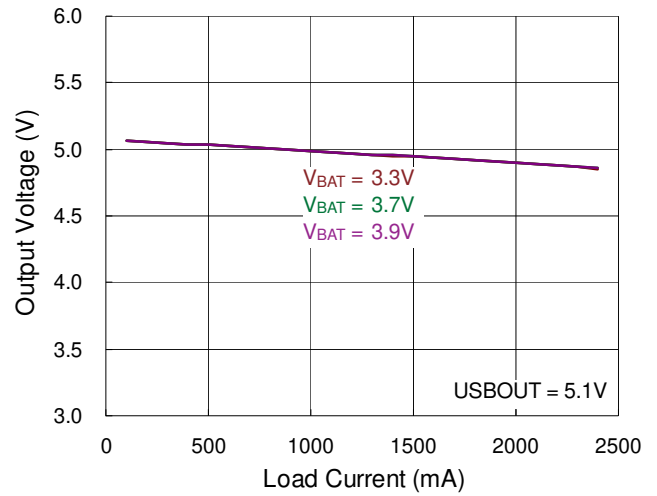

**USBOUT Voltage vs. Temperature**

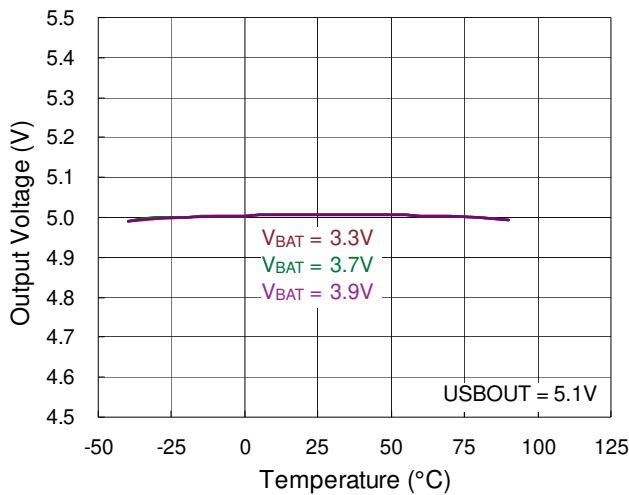

**VBUS OVP Threshold Voltage vs. Temperature**

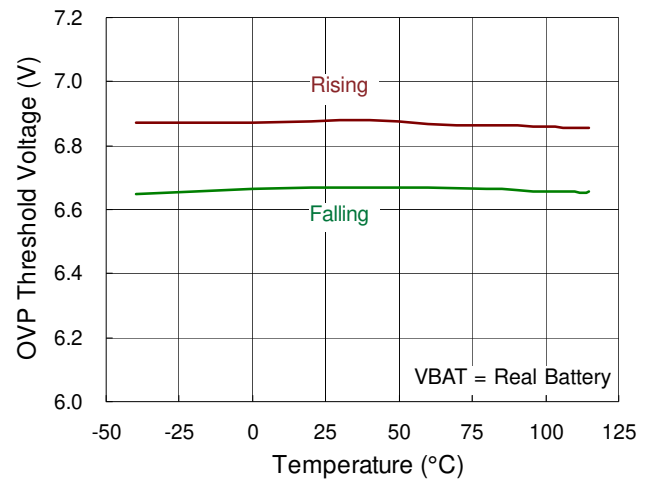

**Battery Regulation Voltage vs. Temperature**

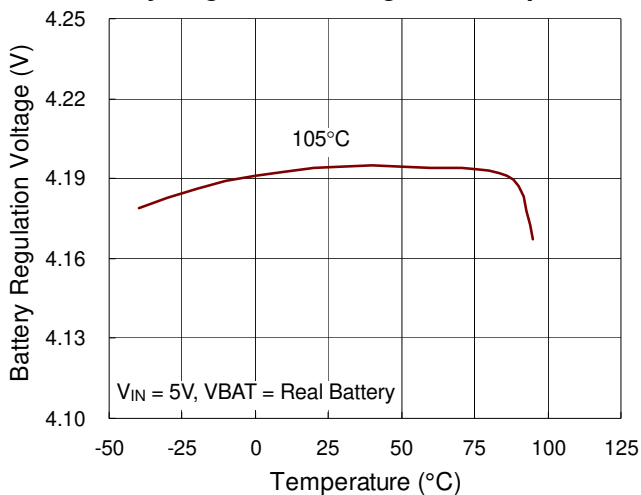

**ICHG Thermal Regulation vs. Temperature**

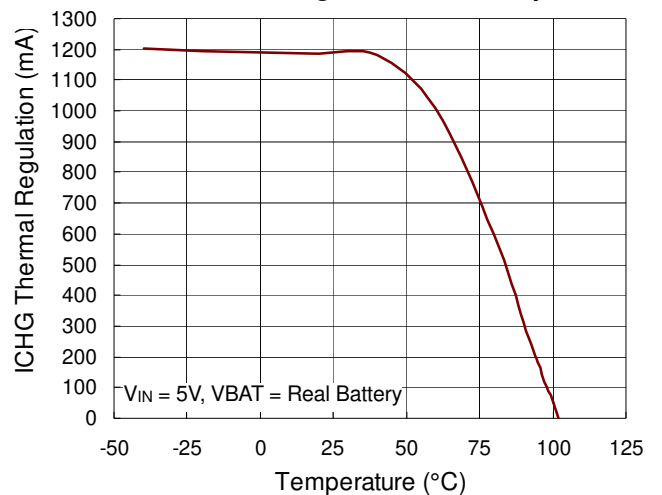

## Application Information

The RT9480 is a high integrated IC for Li-Ion battery power bank. This chip includes a linear charger, a synchronous Boost, two output load management, LED indicator and torch function.

### Pre-Charge Mode

When the output voltage is lower than 2.3V, the charging current will be reduced to a fast-charge current ratio to protect the battery life time.

### Fast-Charge Mode

When the output voltage is higher than 2.5V, the charging current will be equal to the fast-charge current with 1.2A.

### Constant-Voltage Mode

When the output voltage is near 4.2V or 4.35V, the charging current will fall below the termination current.

### Re-Charge Mode

When the chip is in charge termination mode, the charging current will gradually go down to zero. However, once the voltage of the battery drops to below 4.05V or 4.2V, then the charging current will resume again.

### Charge Termination

When the charge current is lower than the charge termination current ratio (10%) for  $V_{BAT} > 4.05V$  or 4.2V and the time is larger than the deglitch time (25ms), it will be latched high unless the power is re-toggled.

### Input DPM Mode

If the input voltage is lower than  $V_{DPM}$  (4.5V), the input current limit will be reduced to stop the input voltage from dropping any further. This can prevent the IC from damaging improperly configured or inadequately designed USB sources.

### Temperature Regulation

In order to maximize charge rate, the RT9480 features a junction temperature regulation loop. If the power dissipation of the IC results in junction temperature greater than the thermal regulation threshold (105°C), the RT9480 will cut back on the charge current and disconnect the

battery in order to maintain thermal regulation at around 105°C. This operation continues until the junction temperature falls below the thermal regulation threshold (105°C) by the hysteresis level. This feature prevents the maximum power dissipation from exceeding typical design conditions.

### Time Fault

The Fast-Charge Fault Time is set by 24hours.

When time fault happens, the charger cycle will be turned off charging function.

### Battery Pack Temperature Monitoring

The RT9480 features an external battery pack temperature monitoring input. The TS input connects to the NTC thermistor in the battery pack to monitor battery temperature and prevent danger over temperature conditions. If at any time the voltage at TS falls outside of the operating range, charging will be suspended. The NTC thermistor recommends using 10kΩ.

### JEITA Function

For JEITA battery temperature standard :

CV regulation voltage will change at the following battery Temp ranges 45°C to 60°C.

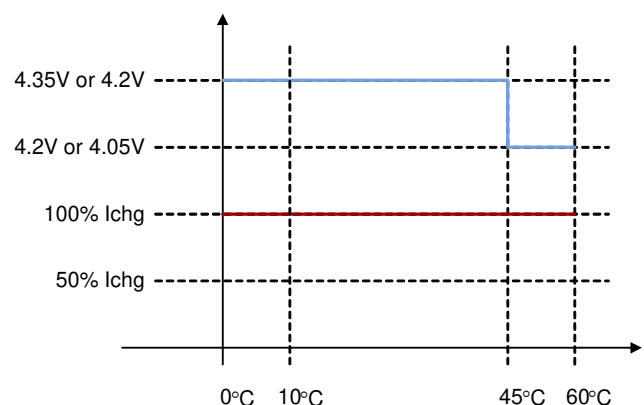

### Synchronous Step-Up

The converter operates in fixed frequency PWM Mode with 250kHz, Continuous Current Mode (CCM), and Discontinuous Current Mode (DCM) with internal MOSFETs.

### Operation Method

Charge Mode : VBUS in and charging battery  
 Discharge Mode : USBOUT in and discharging for handheld  
 Chg-Dchg Mode : VBUS and USBOUT in, charging battery and discharging handheld at the same time  
 Relax Mode : VBUS and USBOUT plug out

### Button Mode

Button mode : When external handheld device plug in for power bank, the USBOUT will turns on by button.  
 If device attached, RT9480 will count 12 hours (RT9480GQW or AA02) or 3sec (AA01 or AA03) to turn off USBOUT after detach.

- ▶ AA01 and AA03. Please reference Product Name List.
- ▶ Attach mean device plug in and loading > 100mA.
- ▶ Detach mean device plug out and loading < 50mA.

### Button Function

Function	Button	Action	Description
Charging	NA	Micro-USB Adapter plug-in : ON	After plugging in the external power source, the power bank will be charged automatically without pressing the button, and the LED battery indicator lights up at the same time.
		Micro-USB Adapter plug-out : OFF	After unplugging the external power source, the power bank stops being charged automatically without pressing the button, and the LED battery indicator fades out at the same time.
Discharging		USB slave plug-in : ON	After plugging in the H/H device and pressing the button, the power bank starts to charge the device.
		USB slave plug-out : OFF	After unplugging the H/H device, the power bank stops charging the device automatically without pressing the button.
Check Battery Capacity		Press the button (short press) one time : ON	Press the button (short press), the LED battery indicator lights up.
		After 20sec : OFF	After 20sec, the LED battery indicator fades out.
Torch		Double click the button (short press) : ON	Double click the button (short press), the torch light lights up.
		Double click the button (short press) : OFF	Double click the button (short press) again, the torch light fades out.

**BUTTON Press Timing**

Define Button (Short/Long) Press Timing

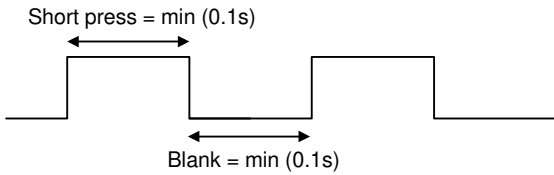

**SOC LED Flash and Running Timing**

SOC LED Flash

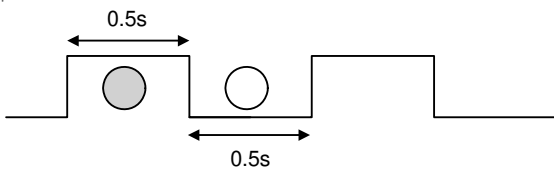

SOC LED Running

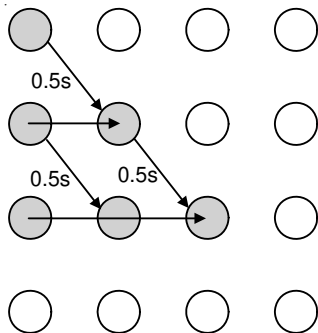

**LED Indicator Function**

About LED indicator, it will follow below table to show SOC. The LED current is 0.75mA.



Low→High

● : LED ON, ○ : LED OFF, ● (red) : LED FLASH

Battery Voltage	Operation of Charging
< 3700mV	
> 3700mV < 3940mV	
> 3940mV < 4100mV	
> 4100mV < 4200mV	
4200mV	

Battery Voltage	Operation of Discharging
< 4200mV > 3880mV	
< 3880mV > 3720mV	
< 3720mV > 3500mV	
< 3500mV > 3200mV	
< 3200mV > 2800mV	

## Thermal Considerations

For continuous operation, do not exceed absolute maximum junction temperature. The maximum power dissipation depends on the thermal resistance of the IC package, PCB layout, rate of surrounding airflow, and difference between junction and ambient temperature. The maximum power dissipation can be calculated by the following formula :

$$P_{D(MAX)} = (T_{J(MAX)} - T_A) / \theta_{JA}$$

where  $T_{J(MAX)}$  is the maximum junction temperature,  $T_A$  is the ambient temperature, and  $\theta_{JA}$  is the junction to ambient thermal resistance.

For recommended operating condition specifications, the maximum junction temperature is 125°C. The junction to ambient thermal resistance,  $\theta_{JA}$ , is layout dependent. For WQFN-24L 4x4 package, the thermal resistance,  $\theta_{JA}$ , is 28°C/W on a standard JEDEC 51-7 four-layer thermal test board. The maximum power dissipation at  $T_A = 25^\circ\text{C}$  can be calculated by the following formula :

$$P_{D(MAX)} = (125^\circ\text{C} - 25^\circ\text{C}) / (28^\circ\text{C/W}) = 3.57\text{W for WQFN-24L 4x4 package}$$

The maximum power dissipation depends on the operating ambient temperature for fixed  $T_{J(MAX)}$  and thermal resistance,  $\theta_{JA}$ . The derating curve in Figure 1 allows the designer to see the effect of rising ambient temperature on the maximum power dissipation.

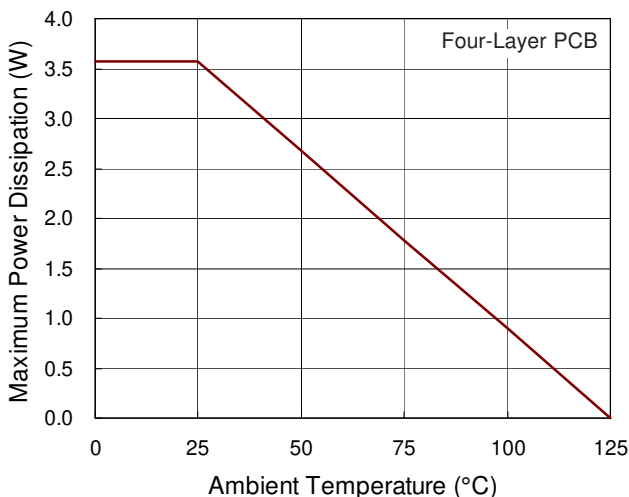

Figure 1. Derating Curve of Maximum Power Dissipation

## Layout Consideration

The PCB layout is an important step to maintain the high performance of the RT9480.

Both the high current and the fast switching nodes demand full attention to the PCB layout to save the robustness of the RT9480 through the PCB layout. Improper layout might show the symptoms of poor line or load regulation, ground and output voltage shifts, stability issues, unsatisfying EMI behavior or worsened efficiency. For the best performance of the RT9480, the following PCB layout guidelines must be strictly followed.

- ▶ Place the input and output capacitors as close as possible to the input and output pins respectively for good filtering.
- ▶ Care should be taken for a proper thermal layout. Wide traces, connecting with vias through the layers, provides a proper thermal path to sink the heat energy created from the device and inductor. Keep the main power traces as wide and short as possible. Recommend as below :

VBUS trace > 40mil;

VBAT trace > 80mil;

LXBST trace > 80mil;

VMID trace > 40mil;

USBOUT1 trace > 80mil;

USBOUT2 trace > 40mil.

- ▶ The switching node area connected to LX and inductor should be minimized for lower EMI.
- ▶ Connect the GND pin, PGNDBST pin and Exposed Pad together to a strong ground plane for maximum thermal dissipation and noise protection.
- ▶ Directly connect the output capacitors to the feedback network of each channel to avoid bouncing caused by parasitic resistance and inductance from the PCB trace.

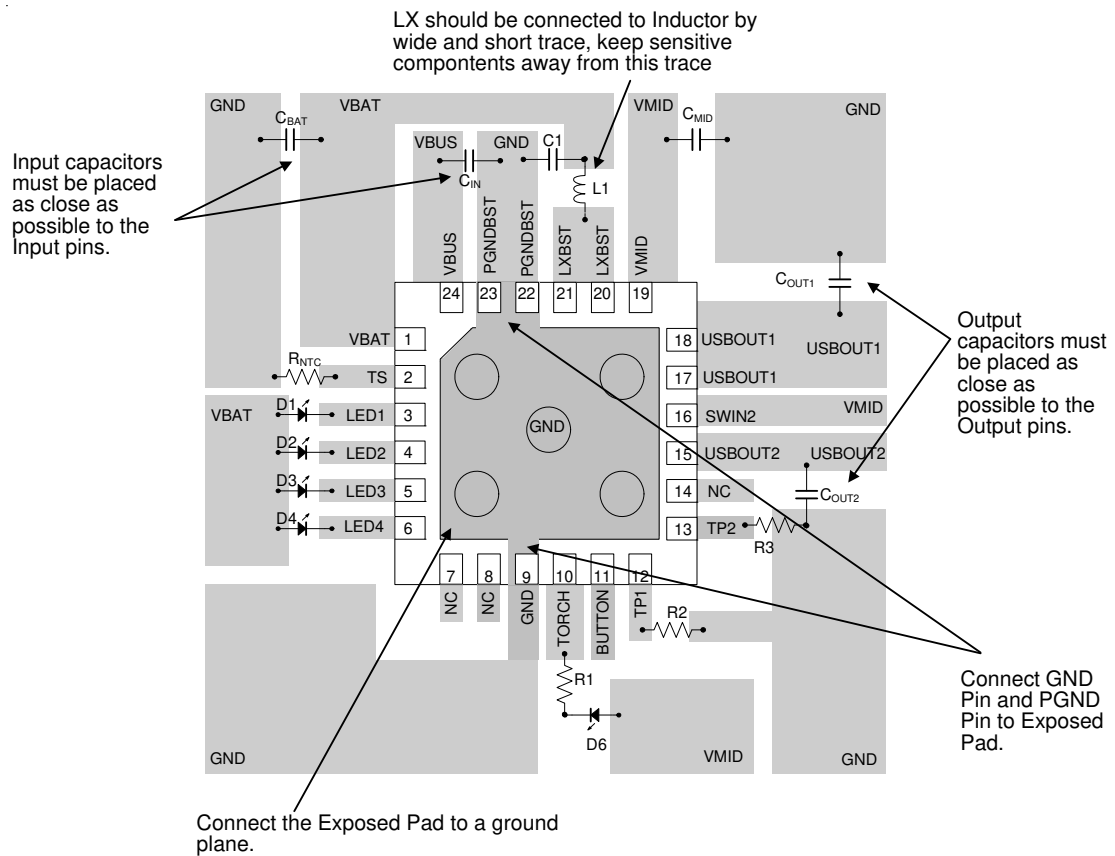
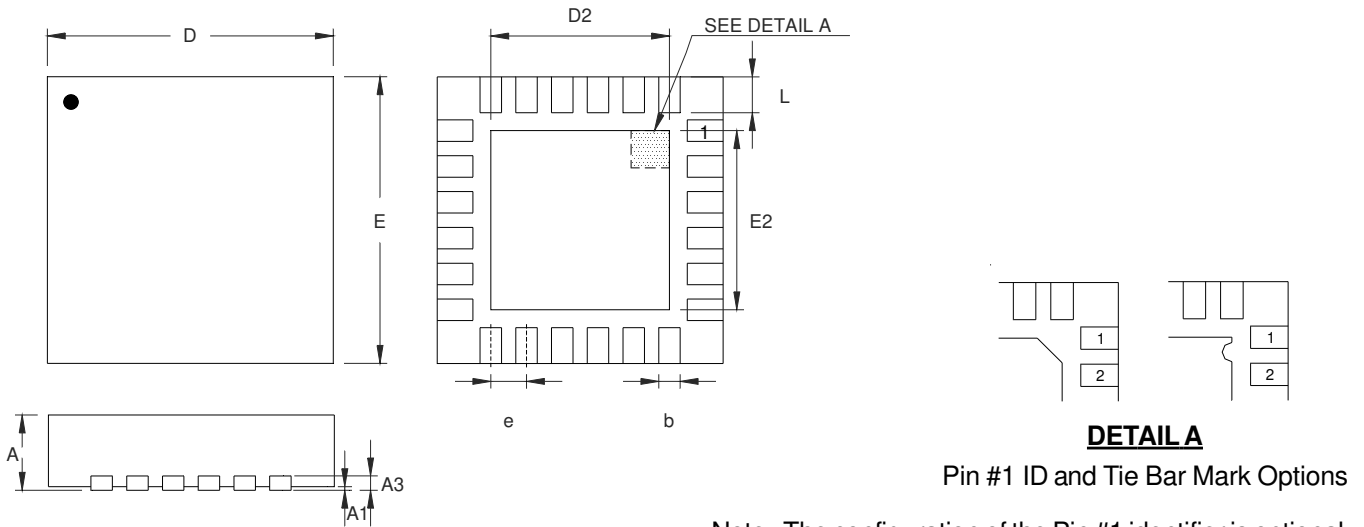

Figure 2. PCB Layout Guide

Outline Dimension



Note : The configuration of the Pin #1 identifier is optional, but must be located within the zone indicated.

Symbol	Dimensions In Millimeters		Dimensions In Inches		
	Min	Max	Min	Max	
A	0.700	0.800	0.028	0.031	
A1	0.000	0.050	0.000	0.002	
A3	0.175	0.250	0.007	0.010	
b	0.180	0.300	0.007	0.012	
D	3.950	4.050	0.156	0.159	
D2	Option 1	2.400	2.500	0.094	0.098
	Option 2	2.650	2.750	0.104	0.108
E	3.950	4.050	0.156	0.159	
E2	Option 1	2.400	2.500	0.094	0.098
	Option 2	2.650	2.750	0.104	0.108
e	0.500		0.020		
L	0.350	0.450	0.014	0.018	

W-Type 24L QFN 4x4 Package

**Richtek Technology Corporation**

14F, No. 8, Tai Yuen 1<sup>st</sup> Street, Chupei City  
Hsinchu, Taiwan, R.O.C.  
Tel: (8863)5526789

Richtek products are sold by description only. Richtek reserves the right to change the circuitry and/or specifications without notice at any time. Customers should obtain the latest relevant information and data sheets before placing orders and should verify that such information is current and complete. Richtek cannot assume responsibility for use of any circuitry other than circuitry entirely embodied in a Richtek product. Information furnished by Richtek is believed to be accurate and reliable. However, no responsibility is assumed by Richtek or its subsidiaries for its use; nor for any infringements of patents or other rights of third parties which may result from its use. No license is granted by implication or otherwise under any patent or patent rights of Richtek or its subsidiaries.