



www.ti.com

WIDEBAND VOLTAGE CONTROLLED AMPLIFIER

FEATURES

- WIDE GAIN CONTROL RANGE: 77dB
- SMALL PACKAGE: SO-8
- WIDE SIGNAL BANDWIDTH: 30MHz
- LOW VOLTAGE NOISE: $2.2\text{nV}/\sqrt{\text{Hz}}$
- FAST GAIN SLEW RATE: $300\text{dB}/\mu\text{s}$

DESCRIPTION

The VCA610 is a wideband, continuously variable, voltage-controlled gain amplifier. It provides linear-dB gain control with high impedance inputs. It is designed to be used as a flexible gain-control element in a variety of electronic systems.

The VCA610 has a gain-control range of 77dB (-38.5dB to $+38.5\text{dB}$) providing both gain and attenuation for maximum flexibility in a small SO-8. The broad attenuation range can be used for gradual or controlled channel turn-on and turn-off for applications in which abrupt gain changes can create artifacts or other errors. In addition, the output can be disabled to provide -77dB of attenuation. Group delay variation with gain is typically less than $\pm 2\text{ns}$ across a bandwidth of 1MHz to 15MHz.

The VCA610 has a noise figure of 3.5dB (with an R_s of 200Ω) including the effects of both current and voltage noise. Instantaneous output dynamic range is 70dB for gains of 0dB to $+38.5\text{dB}$ with 1MHz noise bandwidth. The output is capable of driving 100Ω . The high-speed, $300\text{dB}/\mu\text{s}$, gain-control signal is a unipolar (0V to -2V) voltage that varies the gain linearly in dB/V over a -38.5dB to $+38.5\text{dB}$ range.

APPLICATIONS

- OPTICAL DISTANCE MEASUREMENT
- AGC AMPLIFIERS
- ULTRASOUND
- SONAR
- ACTIVE FILTERS
- LOG AMPLIFIERS
- IF CIRCUITS
- CCD CAMERAS

The VCA610 is designed with a very fast overload recovery time of only 200ns. This allows a large signal transient to overload the output at high gain, without obscuring low-level signals following closely behind. The excellent overload recovery time and distortion specifications optimize this device for low-level doppler measurements.

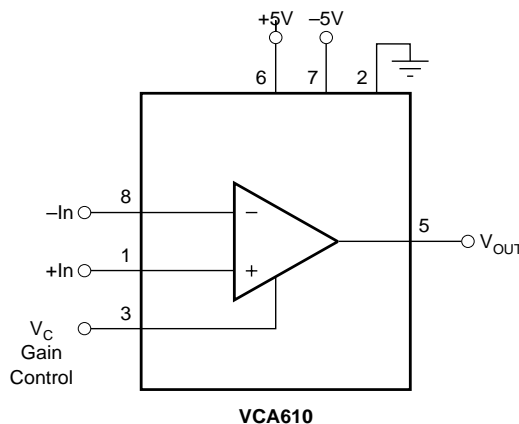

SPECIFICATIONS

ELECTRICAL

All specifications at $V_S = \pm 5V$, $R_L = 500\Omega$, $R_S = 0\Omega$, and $T_A = +25^\circ C$, unless otherwise noted.

PARAMETER	CONDITIONS	VCA610UA			VCA610U			UNITS
		MIN	TYP	MAX	MIN	TYP	MAX	
INPUT NOISE Input Voltage Noise Input Current Noise Noise Figure	$V_C = -2V$ $V_C = 0$ to $-2V$ $V_C = -2V$, $R_S = 200\Omega$		2.2 1.4 3.5			*	*	nV/ \sqrt{Hz} pA/ \sqrt{Hz} dB
INPUT Input Impedance Bias Current Offset Current Differential Voltage Range Common-Mode Voltage Range Common-Mode Rejection	Common-Mode All Gains All Gains		1 1 6 2 (1) ± 2.5 50			*	*	M Ω pF μA μA V dB
GAIN Specified Gain Range Gain Accuracy ⁽²⁾ Gain Accuracy Temperature Drift Gain with Output Disabled	$-2V \leq V_C \leq 0V$ $T_A = -25^\circ C$ to $+85^\circ C$ $+0.1V \leq V_C \leq +2.0V$, $f = 1MHz$	-38.5	± 0.6 ± 0.01 -80	+38.5 ± 2.3	*	± 2 *	* ± 4	dB dB dB/ $^\circ C$ dB
GAIN CONTROL Gain Scaling Factor Control Voltage (V_C) Bandwidth Slew Rate Settling Time: 1% Input Impedance Input Bias Current Output Offset Change ⁽³⁾	$-38.5dB \leq G \leq +38.5dB$ $G = -38.5dB$ ($V_C = 0V$) to $+38.5dB$ ($V_C = -2V$) -3dB 77dB Gain Step $V_{IN} = 10mV_{DC}$, $\Delta G = 77dB$ All Gains $\Delta G = 77dB$	0	38.5 1 300 800 1 1 2 ± 30	-2 ± 75	*	*	*	dB/V V MHz dB/ μs ns M Ω pF μA mV
FREQUENCY RESPONSE Bandwidth, Small-Signal Bandwidth, Large-Signal Group Delay Unit-to-Unit Variation 0dB $\leq G \leq +38.5dB$ -38.5dB $\leq G < 0dB$ Output Slew Rate Overload Recovery ⁽⁴⁾ Two-tone Intermodulation Distortion ⁽⁵⁾ Two-tone, 3rd-Order IMD Intercept ⁽⁵⁾	-3dB, All Gains $V_O = 1Vp-p$, $G \geq 0dB$ $f = 1$ to 15MHz $f = 1$ to 15MHz $V_O = 1Vp-p$ Small-Signal Small-Signal		30 25 ± 1 ± 2 60 200 -50 15			*	*	MHz MHz ns ns V/ μs ns dBc dBm
OUTPUT Voltage Swing ⁽¹⁾ $G = +38.5dB$ $G = 0dB$ Output Voltage Limit Short-Circuit Current Instantaneous Dynamic Range (IDR) ⁽⁶⁾ $G = 0dB$ to $+38.5dB$ Offset Output Resistance	Continuous to Common $V_O = 1.5Vp-p$ $G = -38.5dB$ $f = 1MHz$, All Gains	± 1 ± 0.5 Symmetrical to Ground ($\pm 10\%$)	± 1.6 ± 0.75 ± 80 70 ± 2 10	 ± 30	*	*	*	V V mA dB mV Ω
POWER SUPPLY Specification PSR Quiescent Current	$\pm 5V$ Recommended $G = 0dB$	± 4.5 40	50 -26/+30	± 5.5 ± 32	*	*	*	V dB mA
TEMPERATURE Specification Operation Thermal Resistance, θ_{JA} U, UA	Applies to Temperature Drift Specs	-25 -40		+85 +125	*	*	*	$^\circ C$ $^\circ C$ $^\circ C/W$

* Specifications same as VCA610UA.

NOTES: (1) See Input/Output Range discussion in the Applications Information section (Figure 2). (2) Gain is laser trimmed and tested at control voltages of 0V to -2V in 200mV steps; $V_{IN} = 1Vp-p$ for $V_C > -1V$ gains less than 0dB; $V_{OUT} = 1V$ for $V_C < -1V$. (3) Output offset change from offset at $V_C = 0V$. (4) Gain = +40dB; Input step of 2V to 2mV; time required for output to return from saturation to linear operation. (5) $V_{IN} = 7mVp-p$, $V_{OUT} = 700mVp-p$ (250mVrms); Output Power = -10dBm/line, equal amplitude tones of 5MHz $\pm 500Hz$, $V_C = -2V$. See Typical Performance Curves. (6) With $R_S = 0\Omega$, and noise bandwidth of 1MHz. $IDR = 20 \log(V_{ORMS}/(e_{ORMS} \cdot \sqrt{BW}))$ where V_{ORMS} is rms output voltage, e_{ORMS} is output noise spectral density, and BW is noise bandwidth.

ABSOLUTE MAXIMUM RATINGS

Supply	$\pm 7V$
Differential Input Voltage	Total V_S
Input Voltage Range	See Input Protection Section
Storage Temperature Range	$-65^{\circ}C$ to $+150^{\circ}C$
Lead Temperature (soldering, DIP, 10s)	$+300^{\circ}C$
Lead Temperature (soldering, SO-8, 3s)	$+260^{\circ}C$
Output Short-Circuit to Ground ($+25^{\circ}C$)	Continuous
Junction Temperature (T_J)	$+175^{\circ}C$



ELECTROSTATIC DISCHARGE SENSITIVITY

This integrated circuit can be damaged by Electrostatic Discharge (ESD). Burr-Brown recommends that all integrated circuits be handled with appropriate precautions. Failure to observe proper handling and installation procedures can cause damage.

ESD damage can range from subtle performance degradation to complete device failure. Precision integrated circuits may be more susceptible to damage because very small parametric changes could cause the device not to meet its published specifications.

PIN CONFIGURATION

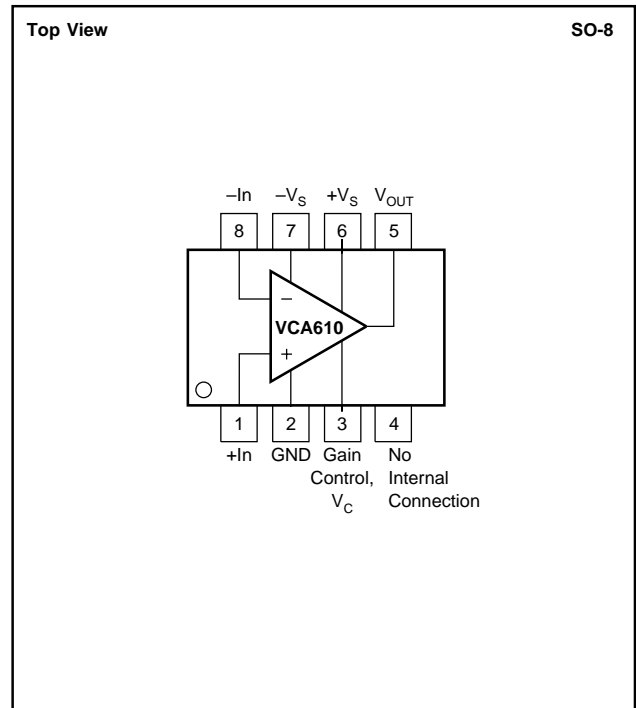

PACKAGE/ORDERING INFORMATION

PRODUCT	PACKAGE	PACKAGE DRAWING NUMBER	SPECIFIED TEMPERATURE RANGE	PACKAGE MARKING	ORDERING NUMBER ⁽¹⁾	TRANSPORT MEDIA
VCA610U	SO-8	182	$-40^{\circ}C$ to $+125^{\circ}C$	VCA610U	VCA610U	Rails
"	"	"	"	"	VCA610U/2K5	Tape and Reel
VCA610UA	SO-8	182	$-40^{\circ}C$ to $+125^{\circ}C$	VCA610UA	VCA610UA	Rails
"	"	"	"	"	VCA610UA/2K5	Tape and Reel

NOTE: (1) Models with a slash (/) are available only in Tape and Reel in the quantities indicated (e.g., /2K5 indicates 2500 devices per reel). Ordering 2500 pieces of VCA610U/2K5 will get a single 2500-piece Tape and Reel.

TYPICAL PERFORMANCE CURVES

At $V_S = \pm 5V$, $R_L = 500\Omega$, $R_S = 0\Omega$, and $T_A = +25^\circ C$, unless otherwise noted.

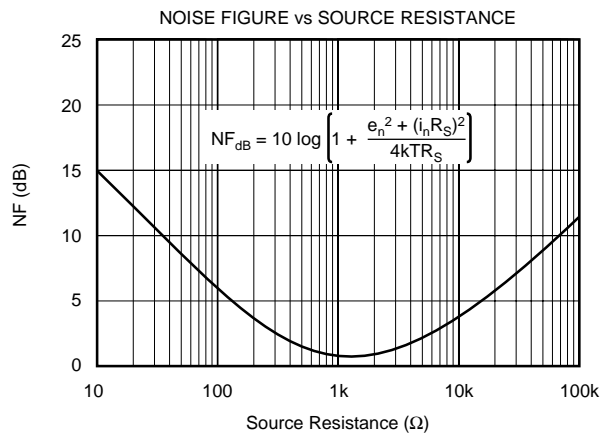
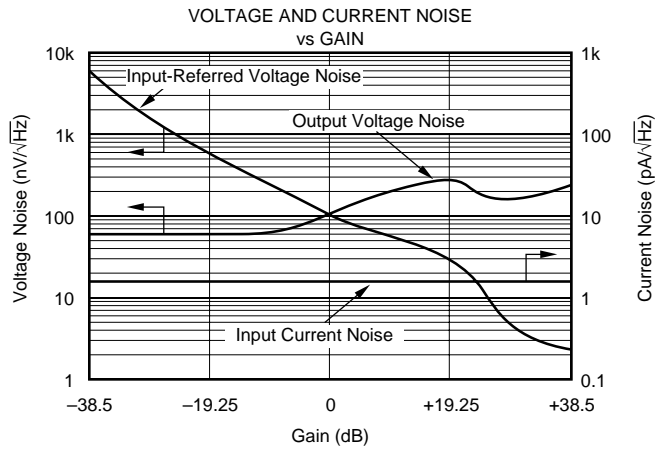
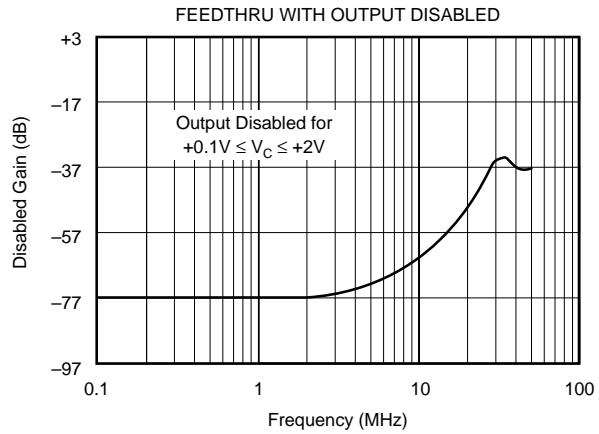
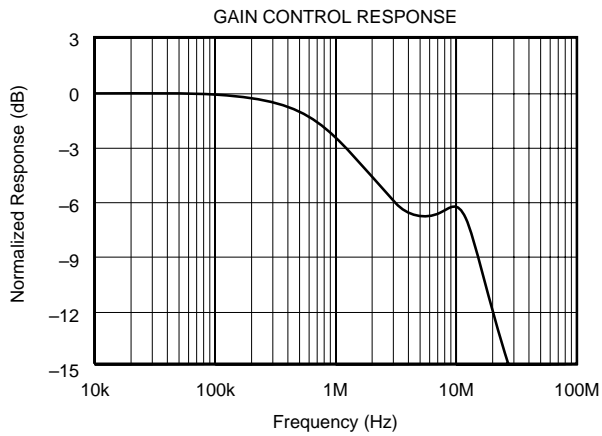
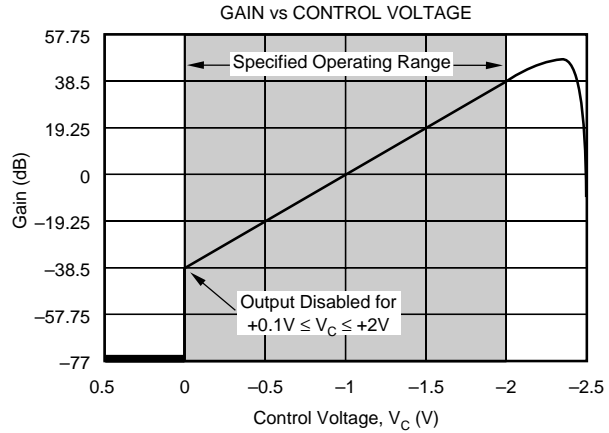
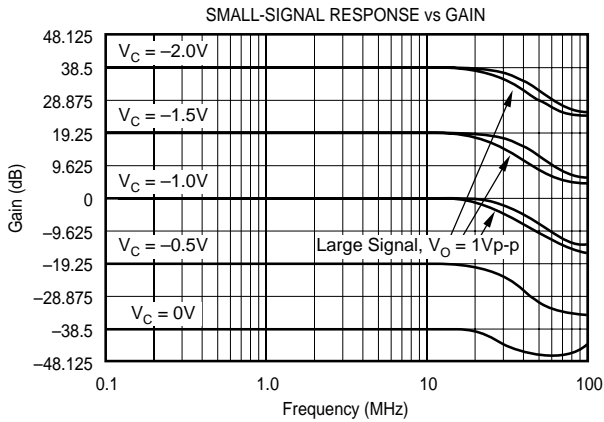

TYPICAL PERFORMANCE CURVES (Cont.)

At $V_S = \pm 5V$, $R_L = 500\Omega$, $R_S = 0\Omega$, and $T_A = +25^\circ C$, unless otherwise noted.

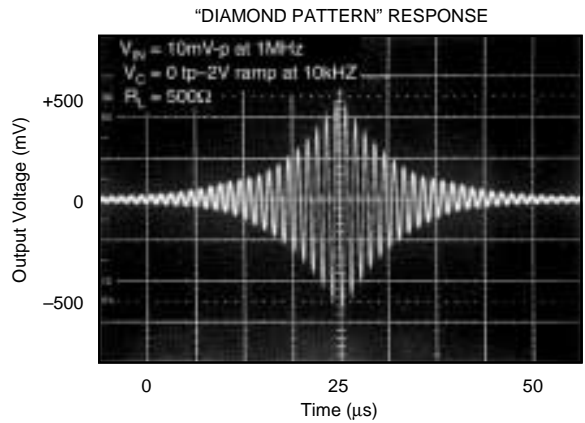
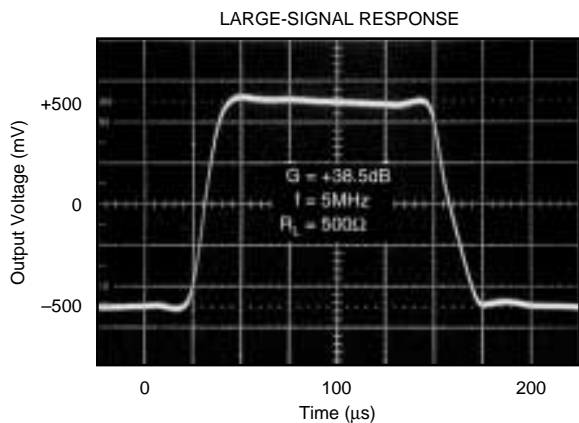
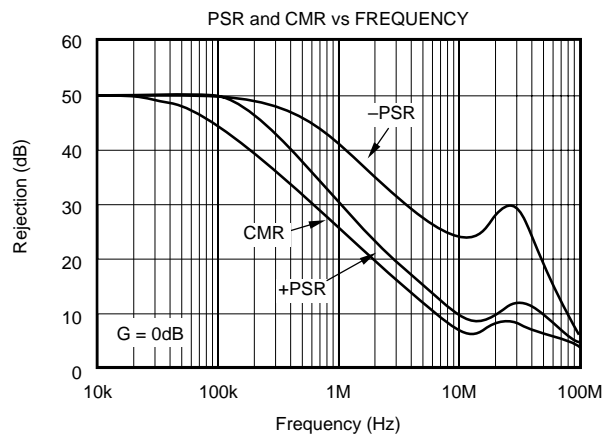
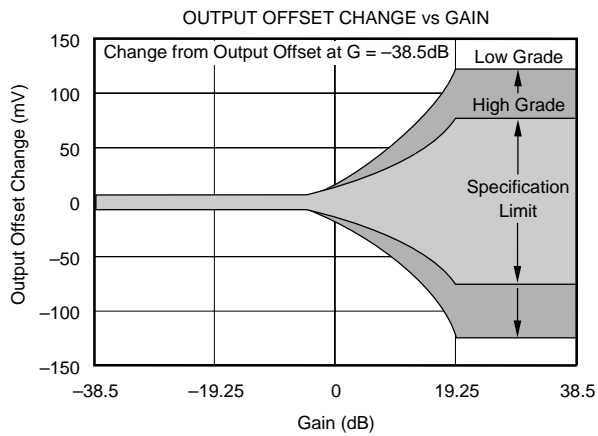
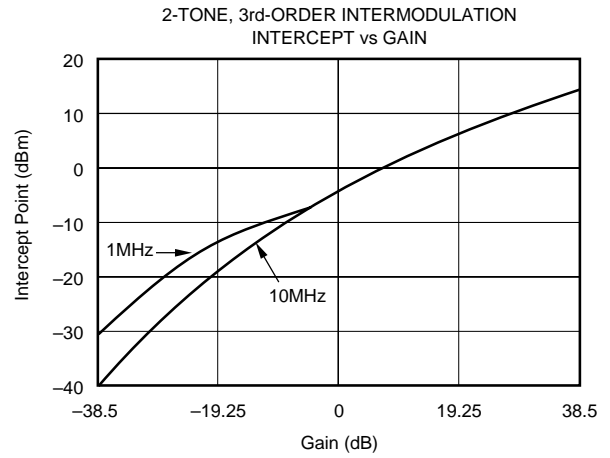
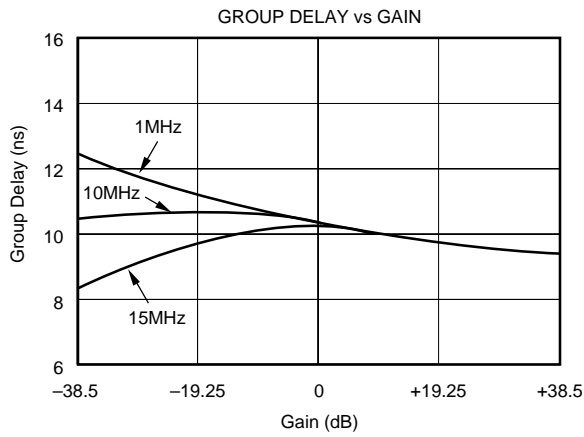

APPLICATIONS INFORMATION

CIRCUIT DESCRIPTION

The VCA610 is a wideband voltage amplifier with a voltage-controlled gain, as modeled in Figure 1. The circuit's basic voltage amplifier responds to the control of an internal gain-control amplifier. At its input, the voltage amplifier presents the high impedance of a differential stage, permitting flexible input impedance matching. To preserve termination options, no internal circuitry connects to the input bases of this differential stage. For this reason, the user should provide DC paths for the input base currents either through a grounded termination resistor or a direct connection to ground. The differential input stage also permits rejection of common-mode signals to remove ground bounce effects. At its output, the voltage amplifier presents the low impedance of class A-B emitter-follower stage, again simplifying impedance matching. An open-loop design produces wide bandwidth at all gain levels and avoids the added overload-recovery and propagation delays of feedback designs. Repeated use of differential stages minimizes offset effects for reduced feedthrough of the gain control signal. A ground-sensing, differential to single-ended converter retains the low offset in the amplifier output stage.

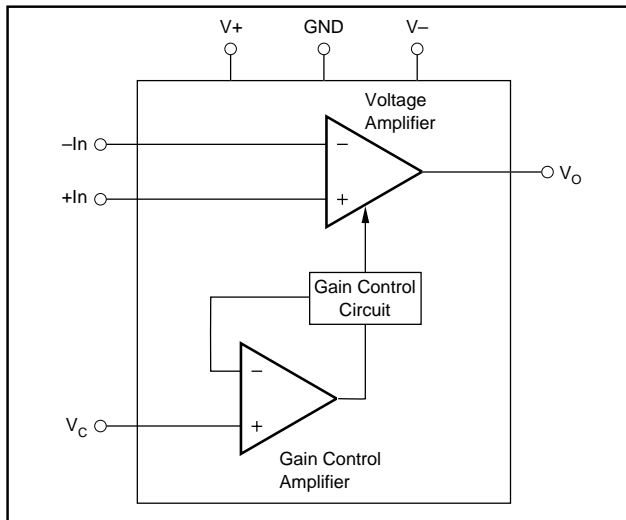

FIGURE 1. Block Diagram of the VCA610.

A user-applied voltage, V_C , controls the amplifier's gain magnitude through a high-speed control circuit. Gain polarity can be either inverting or noninverting depending upon the amplifier input driven by the input signal. Use of the inverting input is recommended since this connection tends to minimize positive feedback from the output to the non-inverting input. The gain control circuit presents the high-input impedance of a noninverting op amp connection.

Control voltage V_C varies the amplifier gain according to the exponential relationship $G (V/V) = 10^{-1.925 (V_C + 1)}$. This translates to the linear, logarithmic relationship $G (dB) = -38.5 + 38.5dB$. Thus, $G (dB)$ varies linearly over the specified $-38.5dB$ to $+38.5dB$ range as V_C varies from

0 to $-2V$. Optionally, making V_C slightly positive ($\geq 0.1V$) effectively disables the amplifier, giving 77dB of attenuation at low frequencies.

Internally, the gain-control circuit varies the amplifier gain through a time-proven method which exploits the linear relationship between the transconductance, g_m , of a bipolar transistor and the transistor's bias current. Varying the bias currents of differential stages varies g_m to control the voltage gain of the VCA610. Relying on transistor g_m to set gain also avoids the need for a noise-producing gain-set resistor in the amplifier input circuit. This reliance normally introduces a high thermal sensitivity to the gain. However, the VCA610 employs specialized analog signal processing that removes this thermal effect.

INPUT/OUTPUT RANGE

The VCA610's 77dB gain range allows the user to handle an exceptionally wide range of input signal levels. If the unit's input and output voltage range specifications are exceeded, however, signal distortion and amplifier overloading will occur. The VCA610's maximum input and output voltage range is best illustrated in Figure 2.

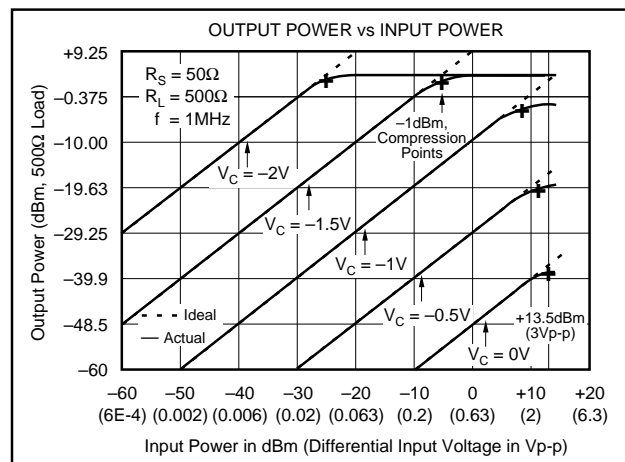

FIGURE 2. Input and Output Range.

Figure 2 plots output power versus input power for five voltage gains spaced at 19.25dB intervals. The 1dBm compression points occur where the actual output power (solid lines) deviates by $-1dBm$ from the ideal output power (dashed lines). Compression is produced by different mechanisms depending on the selected gain. For example, at $G = -38.5dB$ ($V_C = 0$), 1dBm compression occurs when the input signal approaches approximately 3Vp-p (13.5dBm for $R_S = 50\Omega$). Input overloading is the compression mechanism for all gains from $-38.5dB$ to about $-5dB$. For gains between $-5dB$ and $+5dB$, the compression is due to internal gain stage overloading. Compression above a gain of $+5dB$ occurs when the output signal becomes distorted as internal gain stages become overdriven. At $G = 0dB$, 1dBm compression occurs when the input exceeds approximately 1.5Vp-p (7.5dBm). At gains greater than about 5dB, the compression mechanism is due to output stage overloading.

Output overloading occurs when either the maximum output voltage swing or output current is exceeded. The VCA610's high output current of $\pm 80\text{mA}$ insures that virtually all output overloads will be limited by voltage swing rather than by current limiting. At $G = +38.5\text{dB}$ ($V_C = 0\text{V}$), 1dBm compression occurs when the output voltage approaches $3\text{V}_{\text{p-p}}$ (3.5dBm for $R_L = 500\Omega$). Table I below summarizes these results.

GAIN RANGE	OUTPUT COMPRESSION MECHANISM	TO PREVENT OPERATE WITHIN
$-38.5\text{dB} < G < -5\text{dB}$	Input Stage Overload	Input Voltage Range
$-5\text{dB} < G < +5\text{dB}$	Internal Stages Overloading	Output Voltage Range
$+5\text{dB} < G < +38.5\text{dB}$	Output Stage Overload	Output Voltage Range

TABLE I. Output Signal Compression.

WIRING PRECAUTIONS

Maximizing the VCA610's capability requires some wiring precautions and high-frequency layout techniques. In general, printed circuit board conductors should be as short and as wide as possible to provide low-resistance, low-impedance signal paths. Stray signal coupling from the output or power supplies to the inputs should be minimized. Unused inputs should be grounded as close to the package as possible.

Low impedance ground returns for signal and power are essential. Proper supply bypassing is also extremely critical and must *always* be used. Both power supply leads should be bypassed to ground as close as possible to the amplifier pins. Tantalum capacitors ($1\mu\text{F}$ to $10\mu\text{F}$) with very short leads are recommended. Surface-mount bypass capacitors will provide excellent results due to their low lead inductance.

OVERLOAD RECOVERY

As shown in Figure 2, the onset of overload occurs whenever the actual output begins to deviate from the ideal expected output. If possible, the user should operate the VCA610 within the linear regions shown in order to minimize signal distortion and overload delay time. However, instances of amplifier overload are actually quite common in Automatic Gain Control (AGC) circuits which involve the application of variable gain to signals of varying levels. The VCA610's design incorporates circuitry which allows it to recover from most overload conditions in 200ns or less. Overload recovery time is defined as the time required for the output to return from overload to linear operation following the removal of either an input or gain-control overdrive signal.

OFFSET ADJUSTMENT

Where desired, the offset of the VCA610 can be removed as shown in Figure 3. This circuit simply presents a DC voltage to one of the amplifier's inputs to counteract the offset error voltage. For best offset performance, the trim adjustment should be made with the amplifier set at the maximum gain of the intended application. The offset voltage of the VCA610

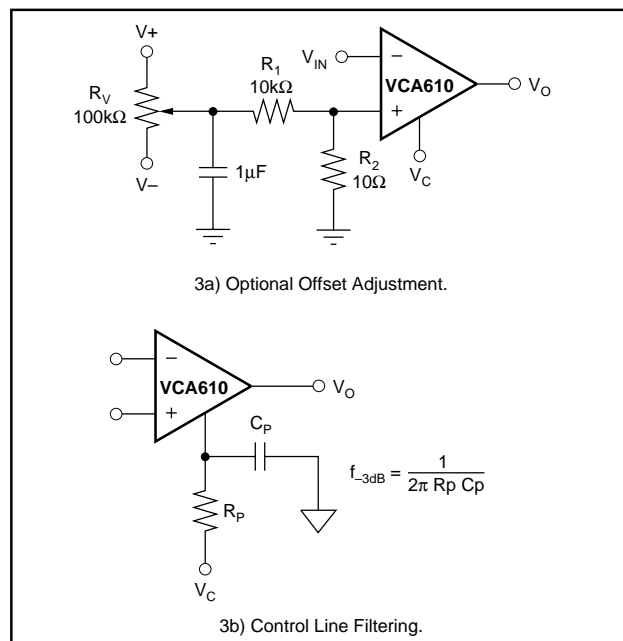

FIGURE 3. Optional Offset Adjustment and Control Line Filtering.

varies with gain, limiting the complete offset cancellation to one selected gain. Selecting the maximum gain optimizes offset performance for higher gains where high amplification of the offset effects produces the greatest output offset. Two features minimize the offset control circuit's noise contribution to the amplifier input circuit. First, making the resistance of R_2 a low value minimizes the noise directly introduced by the control circuit. This reduces both the thermal noise of the resistor and the noise produced by the resistor with the amplifier's input noise current. A second noise reduction results from capacitive bypass of the potentiometer output. This filters out power-supply noise that would otherwise couple to the amplifier input.

This filtering action would diminish as the wiper position approaches either end of the potentiometer, but practical conditions prevent such settings. Over its full adjustment range, the offset control circuit produces a $\pm 5\text{mV}$ offset correction for the values shown. However, the VCA610 only requires one tenth of this range for offset correction, assuring that the potentiometer wiper will always be near the potentiometer center. With this setting, the resistance seen at the wiper remains high and this stabilizes the filtering function.

GAIN CONTROL

The VCA610's gain is controlled by means of a unipolar negative voltage applied between ground and the gain control input, pin 3. If use of the output disable feature is required, a ground-referenced bipolar voltage is needed. Output disable occurs for $+0.1\text{V} \leq V_C \leq +2\text{V}$, and produces 77dB of attenuation. The control voltage should be limited to $+2\text{V}$ in disable mode, and -2V in the gain mode in order to prevent saturation of internal circuitry.

The VCA610's gain-control input has a -3dB bandwidth of 1MHz and varies with frequency, as shown in the Typical Performance Curves. This wide bandwidth, although useful for many applications, can allow high-frequency noise to modulate the gain control input. In practice, this can be easily avoided by filtering the control input, as shown in Figure 3b. R_p should be no greater than 100Ω so as not to introduce gain errors by interacting with the gain control's input bias current of $2\mu\text{A}$.

INPUT PROTECTION

ESD has been well recognized for MOSFET devices, but any high speed device requires protection from this potentially damaging source. The VCA610 incorporates on-chip ESD protection diodes, as shown in Figure 4. This eliminates the need for the user to add external protection diodes, which can add capacitance and degrade AC performance.

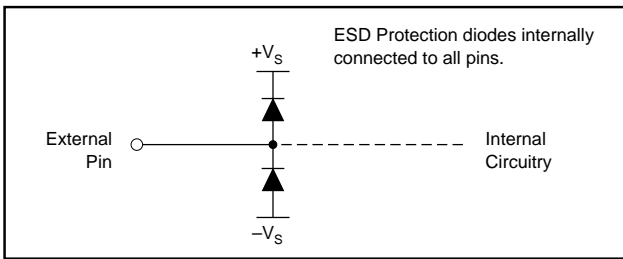

FIGURE 4. Internal ESD Protection.

All pins on the VCA610 are internally protected from ESD by means of a pair of back-to-back reverse-biased diodes to either power supply, as shown in Figure 4. These diodes will begin to conduct when the pin voltage exceeds either power supply by about 0.7V . This situation can occur with loss of the amplifier's power supplies while a signal source is still present. The diodes can typically withstand a continuous current of 30mA without destruction. To insure long-term reliability, however, diode current should be externally limited to 10mA whenever possible.

The internal protection diodes are designed to withstand 2.5kV (using Human Body Model) and provide adequate ESD protection for most normal handling procedures. However, static protection is strongly recommended, since static damage can cause subtle changes in amplifier operational characteristics without necessarily destroying the device.

APPLICATIONS

The electronically variable gain of the VCA610 suits pulse-echo imaging systems well. Such applications include medical imaging, non-destructive structural inspection and optical distance measurement. The amplifier's variable gain also serves AGC amplifiers, amplitude-stabilized oscillators, log amplifiers, and exponential amplifiers. The discussions below present examples of these applications.

ULTRASOUND TGC AMPLIFIER

The Figure 5 block diagram illustrates the fundamental configuration common to pulse-echo imaging systems. A piezoelectric crystal serves as both the ultrasonic pulse generator, and the echo-monitor transducer. A transmit/receive (T/R) switch isolates the monitor amplifier from the crystal during the pulse generation cycle, and then connects the amplifier to the crystal during the echo-monitor cycle.

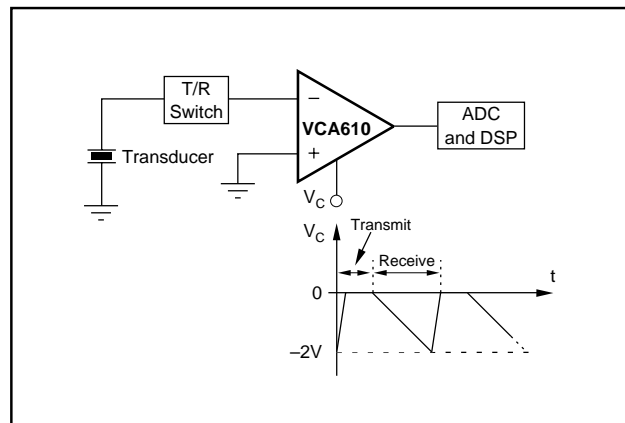

FIGURE 5. Typical Ultrasound Application.

During the monitor (receive) cycle, control voltage V_C varies the amplifier gain. The gain is varied for three basic signal-processing requirements of a transducer array based beamformer: compensation for depth attenuation effects, sometimes called Time Gain Compensation (TGC); receive apodization or windowing for reducing side lobe energy; and dynamic aperture sizing for better near field resolution.

Time gain compensation increases the amplifier's gain as the ultrasound signal moves through the material to compensate for signal attenuation versus material depth. For this purpose, a ramp signal applied to the VCA610 gain control

input linearly increases the dB gain of the VCA610 with time. The gain control provides signal apodization or windowing with transducer arrays connected to amplifier arrays. Selective weighting of amplifier gains across the transducer aperture suppresses side lobe effects in the beamformer output to reduce image artifacts. Gain controlled attenuation or disabling the amplifier can be used to dynamically size the array aperture for better near field resolution. The controlled attenuation of the VCA610 minimizes switching artifacts and eliminates the bright radial rings that can result. The VCA610's 77dB gain range accommodates these functions.

WIDE-RANGE LOW-NOISE VCA

Figure 6 combines two VCA610s in series, extending the overall gain range and improving noise performance. This combination produces a gain equal to the sum of the two amplifier's logarithmic gains for a composite range of -77dB to +77dB. Simply connecting V_{C1} and V_{C2} to the same 0V to -2V gain-control voltage can produce this range, however, separate control voltages for the two amplifiers offer a noise-performance improvement. In that configuration, each amplifier separately controls one half the gain range in a manner that always holds G_1 at the maximum level possible.

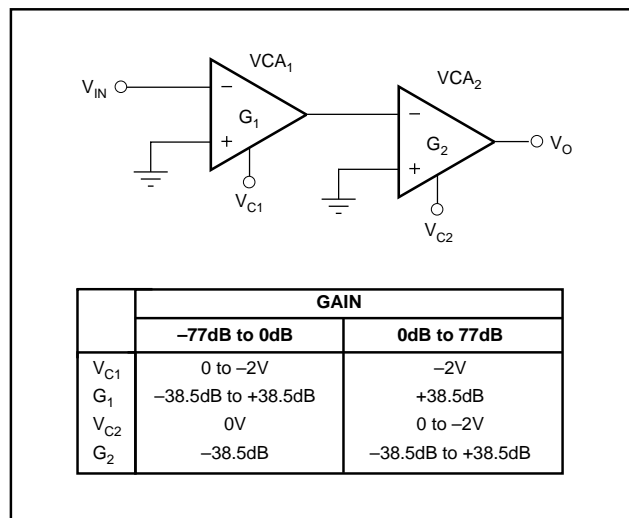

FIGURE 6. Two Series Connected VCA610s Expand the Gain Range and Improve Noise Performance.

At higher gains, variation of V_{C2} alone makes VCA_2 provide all of the gain control, leaving the gain of VCA_1 fixed at its maximum of +38.5dB. This gain maximum corresponds to the maximum bias currents in VCA_1 , minimizing this amplifier's noise. Thus, for composite circuit gains of 0dB to +77dB, V_{CA1} serves as a low-noise, fixed-gain preamp.

For lower composite gains, VCA_1 provides the gain control and VCA_2 acts as a fixed attenuator. There, variation of V_{C1} varies G_1 from -38.5dB to +38.5dB while V_{C2} remains fixed at 0V for $G_2 = -38.5dB$. This mode produces the -77dB to 0dB segment of the composite gain range.

WIDE-RANGE AGC AMPLIFIER

The voltage-controlled gain feature of the VCA610 makes this amplifier ideal for precision AGC applications with control ranges as large as 60dB. The AGC circuit of Figure 7 adds an op amp and diode for amplitude detection, a holding capacitor to store the control voltage and resistors R_1 through R_3 that determine attack and release times. Resistor R_4 and capacitor C_C phase compensate the AGC feedback loop. The op amp compares the positive peaks of output V_O with a DC reference voltage V_R . Whenever a V_O peak exceeds V_R , the OPA680 output swings positive, forward biasing the diode and charging the holding capacitor. This drives the capacitor voltage in a positive direction, reducing the amplifier gain. R_3 and the C_H largely determine the attack time of this AGC correction.

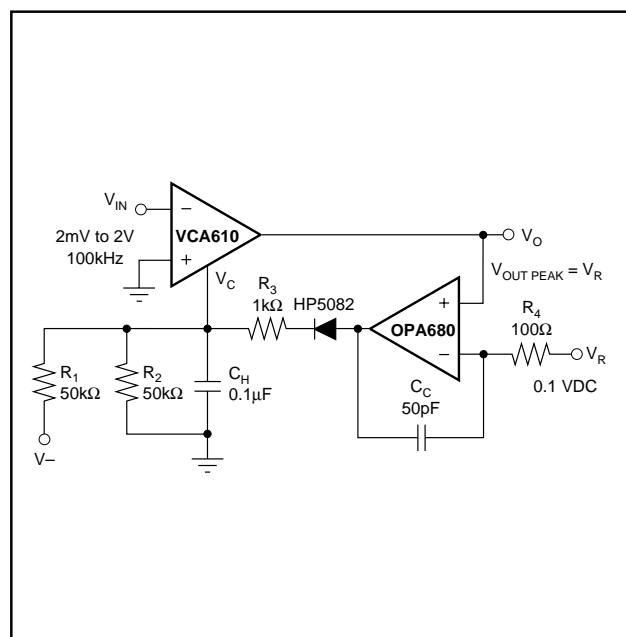

FIGURE 7. This AGC Circuit Maintains a Constant Output Amplitude for a 1000:1 Input Range.

Between gain corrections, resistor R_1 charges the capacitor in a negative direction, increasing the amplifier gain. R_1 , R_2 , and C_H determine the release time of this action. Resistor R_2 forms a voltage divider with R_1 , limiting the maximum negative voltage developed on C_H . This limit prevents input overload of the VCA610's gain control circuit.

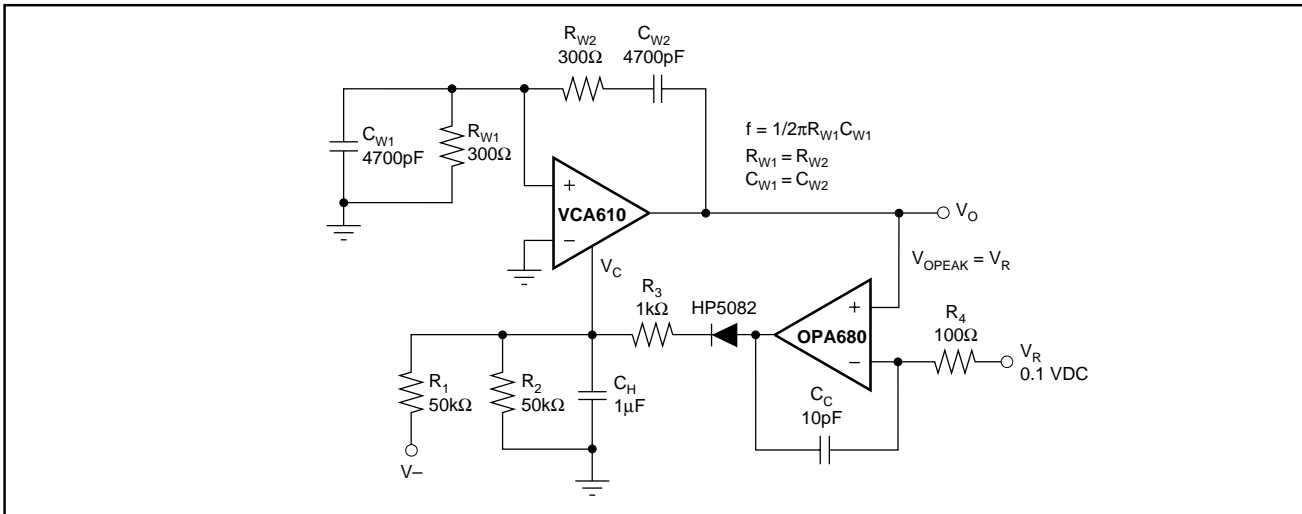

FIGURE 8. Adding Wein-Bridge Feedback to the AGC Circuit of Figure 7 Produces an Amplitude-Stabilized Oscillator.

STABILIZED WEIN-BRIDGE OSCILLATOR

Adding Wein-bridge feedback to the above AGC amplifier produces an amplitude-stabilized oscillator. Shown in Figure 8, this alternative requires the addition of just two resistors (R_{W1} , R_{W2}) and two capacitors (C_{W1} , C_{W2}).

Connecting the feedback network to the amplifier's noninverting input introduces positive feedback to induce oscillation. The feedback factor displays a frequency dependence due to the changing impedances of the C_W capacitors. As frequency increases, the decreasing impedance of the C_{W2} increases the feedback factor. Simultaneously, the decreasing impedance of the C_{W1} decreases this factor.

Analysis shows that the maximum factor occurs at $f = 1/2\pi R_W C_W$, making this the frequency most conducive to oscillation. At this frequency the impedance magnitude of C_W equals R_W and inspection of the circuit shows that this condition produces a feedback factor of 1/3. Thus, self-sustaining oscillation requires a gain of three through the amplifier. The AGC circuitry establishes this gain level. Following initial circuit turn on, R_1 begins charging C_H negative, increasing the amplifier gain from its minimum. When this gain reaches three, oscillation begins at $f = 1/2\pi R_W C_W$ and R_1 's continued charging effect makes the oscillation amplitude grow. This growth continues until that amplitude reaches a peak value equal to V_R . Then, the AGC circuit counteracts the R_1 effect, controlling the peak amplitude at V_R by holding the amplifier gain at a level of three. Making V_R an AC signal, rather than a DC reference, produces amplitude modulation of the oscillator output.

LOW-DRIFT WIDEBAND LOG AMP

The VCA610 can be used to provide a 250kHz (–3dB) log amp with low offset voltage and low gain drift.

The exponential gain-control characteristic of the VCA610 permits simple generation of a temperature-compensated logarithmic response. Enclosing the exponential function in an op amp feedback path inverts this function, producing the log

response. Figure 9 shows the practical implementation of this technique. A DC reference voltage, V_R , sets the VCA610 inverting input voltage. This makes the amplifier's output voltage $V_{OA} = -GV_R$, where $G = 10^{-1.925(V_C + 1)}$.

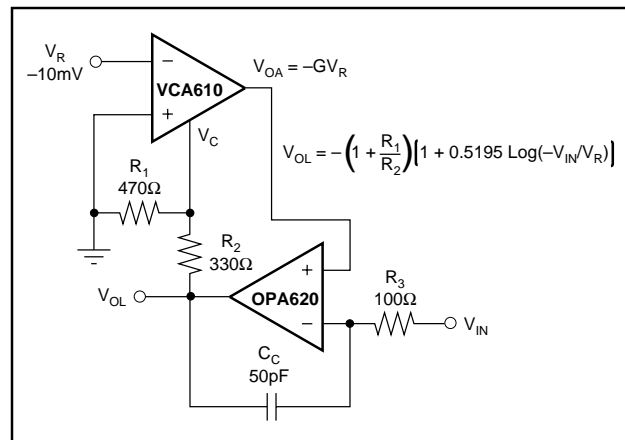

FIGURE 9. Driving the Gain Control Pin of the VCA610 with a Feedback Amplifier Produces a Temperature-Compensated Log Response.

A second input voltage also influences V_{OA} through control of gain G . The feedback op amp forces V_{OA} to equal the input voltage V_{IN} connected at the op amp inverting input. Any difference between these two signals drops across R_3 , producing a feedback current that charges C_C . The resulting change in V_{OL} adjusts the gain of the VCA610 to change V_{OA} . At equilibrium, $V_{OA} = V_{IN} = -V_R 10^{-1.925(V_C + 1)}$. The op amp forces this equality by supplying the gain control voltage $V_C = R_1 V_{OL} / (R_1 + R_2)$. Combining the last two expressions and solving for V_{OL} yields the circuit's logarithmic response:

$$V_{OL} = - (1 + R_2/R_1) [1 + 0.5195 \text{LOG} (-V_{IN}/V_R)]$$

Examination of this result illustrates several circuit characteristics. First, the argument of the log term, $-V_{IN}/V_R$, reveals an option and a constraint. In Figure 9, V_R represents a DC reference voltage. Optionally, making this voltage a second signal produces log-ratio operation. Either way, the log term's argument constrains the polarities of V_R and V_{IN} . These two voltages must be of opposite polarities to ensure a positive argument. This polarity combination results when V_R connects to the inverting input of the VCA610. Alternately, switching V_R to this amplifier's noninverting input removes the minus sign of the log term's argument. Then, both voltages must be of the same polarity to produce a positive argument. In either case, the positive polarity requirement of the argument restricts V_{IN} to a unipolar range.

The above V_{OL} expression reflects a circuit gain introduced by the presence of R_1 and R_2 . This feature adds a convenient scaling control to the circuit. However, a practical matter sets a minimum level for this gain. The voltage divider formed by R_1 and R_2 attenuates the voltage supplied to the V_C terminal by the op amp. This attenuation must be great enough to prevent any possibility of an overload voltage at the V_C terminal. Such an overload saturates the VCA610's gain-control circuitry, reducing the amplifier's gain. For the feedback connection of Figure 9, this overload condition permits a circuit latch. To prevent this, choose R_1 and R_2 to ensure that the op amp can not possibly deliver more than 2.5V to the V_C terminal.

LOW-DRIFT WIDEBAND EXPONENTIAL AMP

A common use of the log amp above involves signal companding. The inverse function, signal expanding, requires an exponential transfer function. The VCA610 produces this latter response directly as shown in Figure 10. DC reference V_R again sets the amplifier's input voltage and the input signal V_{IN} now drives the gain control point. Resistors R_1 and R_2 attenuate this drive to prevent overloading the gain control input. Setting these resistors at the same values as in the preceding log amp produces an exponential amplifier with the inverse function of the log amp.

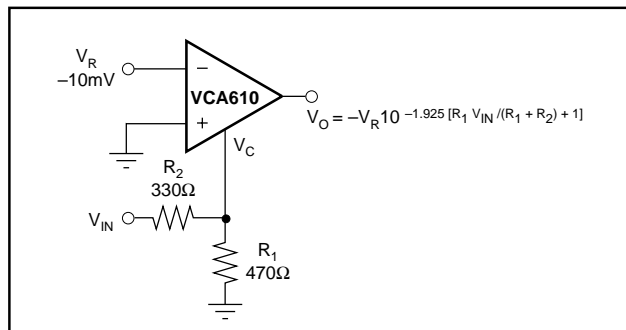

FIGURE 10. Signal Drive of the VCA610 Gain Control Pin Produces an Exponential Response, Re-expanding Signal Companded by Figure 9.

VOLTAGE-CONTROLLED LOW-PASS FILTER

In the circuit of Figure 11, the VCA610 serves as the variable-gain element of a voltage-controlled low-pass filter. As will be described, this implementation expands the circuit's voltage swing capability over that normally achieved with the equivalent multiplier implementation. The circuit's response pole responds to control voltage V_C according to the relationship $f_p = G/2\pi R_2 C$ where $G = 10^{-1.925 (V_C + 1)}$. With the components shown, the circuit provides a linear variation of the low-pass cutoff from 300Hz to 1MHz.

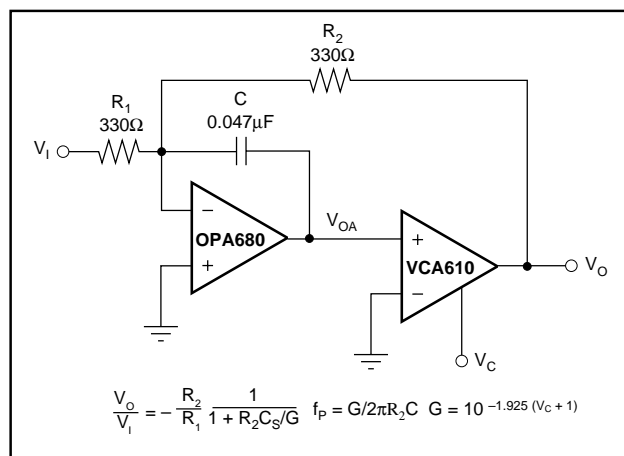

FIGURE 11. This Voltage-Tuneable Low-Pass Filter Produces a Variable Cutoff Frequency with a 3,000:1 Range.

The response control results from amplification of the feedback voltage applied to R_2 . Consider first the case where the VCA610 produces $G = 1$. Then, the circuit performs as if this amplifier were replaced by a short circuit. Visually doing so leaves a simple voltage amplifier with a feedback resistor bypassed by a capacitor. This basic circuit produces a response pole at $f_p = 1/2\pi R_2 C$.

For $G > 1$, the circuit applies a greater voltage to R_2 , increasing the feedback current this resistor supplies to the summing junction of the OPA620. The increased feedback current produces the same result as if R_2 had been decreased in value in the basic circuit described above. Decreasing the effective R_2 resistance moves the circuit's pole to a higher frequency, producing the $f_p = G/2\pi R_2 C$ response control.

Finite loop gain and a signal-swing limitation set performance boundaries for the circuit. Both limitations occur when the VCA610 attenuates rather than amplifies the feedback signal. These two limitations reduce the circuit's utility at the lower extreme of the VCA610's gain range. For $-1 \leq V_C \leq 0$, this amplifier produces attenuating gains in the range from 0dB to -38.5 dB. This directly reduces the net gain in the circuit's feedback loop, increasing gain error

effects. Additionally, this attenuation transfers an output swing limitation from the OPA680 output to the overall circuit's output. Note that OPA680 output voltage, V_{OA} , relates to V_O through the expression $V_O = GV_{OA}$. Thus, a $G < 1$ limits the maximum V_O swing to a value less than the maximum V_{OA} swing.

However, the circuit shown provides greater output swing than the more common multiplier implementation. The latter replaces the VCA610 of the figure with an analog multiplier having a response of $V_O = XY/10$. $X = V_{OA}$ and $Y = V_C$, making the circuit output voltage $V_O = V_{OA}V_C/10$. Thus, the multiplier implementation amplifies V_{OA} by a gain of $V_C/10$. Circuit constraints require that $V_C \leq 10$, making this gain ≤ 1 . Thus, the multiplier performs only as a variable attenuator and never provides amplification. As a result, the voltage swing limitation of V_{OA} restricts the V_O swing throughout most of the circuit's control range. Replacing the multiplier with the VCA610 shown permits equivalent gains > 1 . Operating the VCA610 with gains in the range of 1 to 100 avoids the reduction in output swing capability.

VOLTAGE-CONTROLLED HIGH-PASS FILTER

A circuit analogous to the above low-pass filter produces a voltage-controlled high-pass response. The gain control provided by the VCA610 of Figure 12 varies this circuit's response zero from 1Hz to 10kHz according to the relationship $f_z \approx 1/2\pi GR_1C$ where $G = 10^{-1.925(V_C + 1)}$.

To visualize the circuit's operation, consider a circuit condition and an approximation that permit replacing the VCA610 and R_3 with short circuits. First consider the case where the VCA610 produces $G = 1$. Replacing this amplifier with short

circuit leaves the operation unchanged. In this shorted state, the circuit is simply a voltage amplifier with an R-C bypass around R_1 . The resistance of this bypass, R_3 , serves only to phase compensate the circuit and practical factors make $R_3 \ll R_1$. Neglecting R_3 for the moment, the circuit becomes just a voltage amplifier with capacitive bypass of R_1 . This circuit produces a response zero at $f_z = 1/2\pi R_1C$.

Adding the VCA610 as shown permits amplification of the signal applied to capacitor C and produces voltage control of the frequency f_z . Amplified signal voltage on C increases the signal current conducted by the capacitor to the op amp feedback network. The result is the same as if C had been increased in value to GC . Replacing C with this effective capacitance value produces the circuit's control expression $f_z = 1/2\pi R_1GC$.

Two factors limit the high-frequency performance of the resulting high-pass filter. The finite bandwidth of the op amp and the circuit's phase compensation produce response poles. These limit the frequency duration of the high-pass response. Selecting the R_3 phase compensation with the equation $R_3 = \sqrt{(R_1/2\pi f_c C)}$ assures stability for all values of G and sets the circuit's bandwidth at $BW = \sqrt{(f_c/2\pi R_1 C)}$. Here, f_c is the unity-gain crossover frequency of the op amp used. With the components shown, $BW = 100\text{kHz}$. This bandwidth provides a high-pass response duration of five decades of frequency for $f_z = 1\text{Hz}$, dropping to one decade for $f_z = 10\text{kHz}$.

The output voltage limit of the VCA610 imposes an input voltage limit for the filter. The expression $V_{OA} = GV_I$ relates these two voltages. Thus, an output voltage limit V_{OAL} constrains the input voltage to $V_I \leq V_{OAL}/G$.

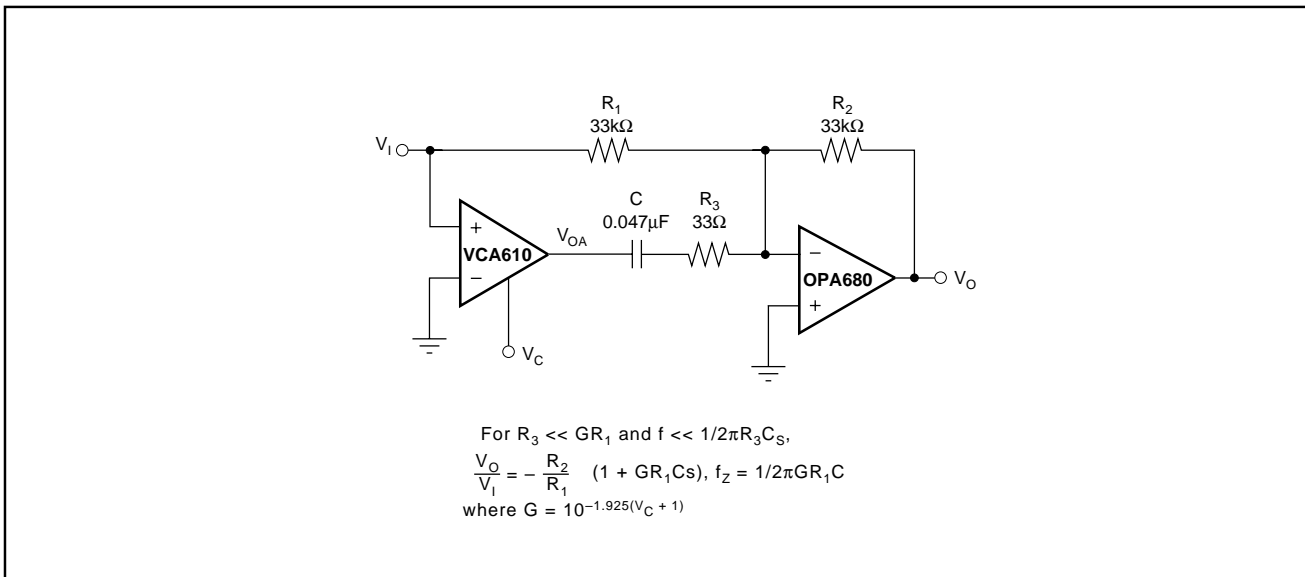

FIGURE 12. A Voltage-Tunable High-Pass Filter Produces a Response Zero Variable from 1Hz to 10kHz.

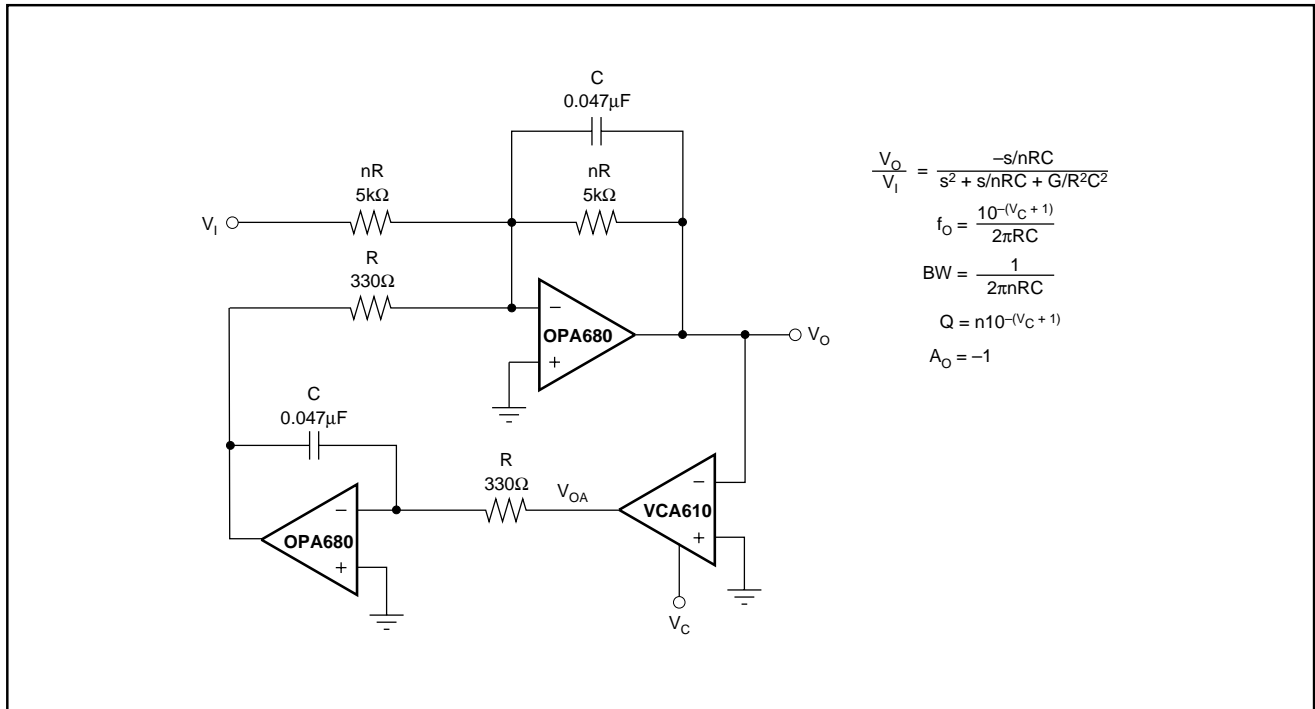

FIGURE 13. Adding the VCA610 to a State-Variable Filter Produces a Voltage-Controlled BandPass Filter With a Center Frequency Variable Over a 100:1 Range.

VOLTAGE-CONTROLLED BAND-PASS FILTER

The VCA610's variable gain also provides voltage control over the center frequency of a band-pass filter. Shown in Figure 13, this filter follows from the state-variable configuration with the VCA610 replacing the inverter common to that configuration. Variation of the VCA610 gain moves the filter's center frequency through a 100:1 range following the relationship $f_o = [10^{-(V_C + 1)}] / 2\pi RC$.

As before, variable gain controls a circuit time constant to vary the filter response. The gain of the VCA610 amplifies or attenuates the signal driving the lower integrator of the circuit. This alters the effective resistance of the integrator time constant producing the response:

$$\frac{V_o}{V_i} = \frac{-s/nRC}{s^2 + s/nRC + G/R^2C^2}$$

Evaluation of this response equation reveals a passband gain of $A_o = -1$, a bandwidth of $BW = 1/2\pi nRC$, and a selectivity of $Q = n10^{-(V_C + 1)}$. Note that variation of control voltage V_C alters Q but not bandwidth.

The gain provided by the VCA610 restricts the output swing of the filter. Output signal V_o must be constrained to a level that does not drive the VCA610 output, V_{OA} , into its saturation limit. Note that these two outputs have voltage swings related by $V_{OA} = GV_o$. Thus, a swing limit V_{OAL} imposes a circuit output limit of $V_{OL} \leq V_{OAL}/G$.

PACKAGING INFORMATION

Orderable Device	Status ⁽¹⁾	Package Type	Package Drawing	Pins	Package Qty	Eco Plan ⁽²⁾	Lead/Ball Finish	MSL Peak Temp ⁽³⁾
VCA610P	OBSOLETE	PDIP	P	8		None	Call TI	Call TI
VCA610PA	OBSOLETE	PDIP	P	8		None	Call TI	Call TI
VCA610U	LIFEBUY	SOIC	D	8		None	Call TI	Call TI
VCA610UA	LIFEBUY	SOIC	D	8		None	Call TI	Call TI
VCA610UA/2K5	LIFEBUY	SOIC	D	8		None	Call TI	Call TI

⁽¹⁾ The marketing status values are defined as follows:

ACTIVE: Product device recommended for new designs.

LIFEBUY: TI has announced that the device will be discontinued, and a lifetime-buy period is in effect.

NRND: Not recommended for new designs. Device is in production to support existing customers, but TI does not recommend using this part in a new design.

PREVIEW: Device has been announced but is not in production. Samples may or may not be available.

OBSOLETE: TI has discontinued the production of the device.

⁽²⁾ Eco Plan - May not be currently available - please check <http://www.ti.com/productcontent> for the latest availability information and additional product content details.

None: Not yet available Lead (Pb-Free).

Pb-Free (RoHS): TI's terms "Lead-Free" or "Pb-Free" mean semiconductor products that are compatible with the current RoHS requirements for all 6 substances, including the requirement that lead not exceed 0.1% by weight in homogeneous materials. Where designed to be soldered at high temperatures, TI Pb-Free products are suitable for use in specified lead-free processes.

Green (RoHS & no Sb/Br): TI defines "Green" to mean "Pb-Free" and in addition, uses package materials that do not contain halogens, including bromine (Br) or antimony (Sb) above 0.1% of total product weight.

⁽³⁾ MSL, Peak Temp. -- The Moisture Sensitivity Level rating according to the JEDEC industry standard classifications, and peak solder temperature.

Important Information and Disclaimer: The information provided on this page represents TI's knowledge and belief as of the date that it is provided. TI bases its knowledge and belief on information provided by third parties, and makes no representation or warranty as to the accuracy of such information. Efforts are underway to better integrate information from third parties. TI has taken and continues to take reasonable steps to provide representative and accurate information but may not have conducted destructive testing or chemical analysis on incoming materials and chemicals. TI and TI suppliers consider certain information to be proprietary, and thus CAS numbers and other limited information may not be available for release.

In no event shall TI's liability arising out of such information exceed the total purchase price of the TI part(s) at issue in this document sold by TI to Customer on an annual basis.

IMPORTANT NOTICE

Texas Instruments Incorporated and its subsidiaries (TI) reserve the right to make corrections, modifications, enhancements, improvements, and other changes to its products and services at any time and to discontinue any product or service without notice. Customers should obtain the latest relevant information before placing orders and should verify that such information is current and complete. All products are sold subject to TI's terms and conditions of sale supplied at the time of order acknowledgment.

TI warrants performance of its hardware products to the specifications applicable at the time of sale in accordance with TI's standard warranty. Testing and other quality control techniques are used to the extent TI deems necessary to support this warranty. Except where mandated by government requirements, testing of all parameters of each product is not necessarily performed.

TI assumes no liability for applications assistance or customer product design. Customers are responsible for their products and applications using TI components. To minimize the risks associated with customer products and applications, customers should provide adequate design and operating safeguards.

TI does not warrant or represent that any license, either express or implied, is granted under any TI patent right, copyright, mask work right, or other TI intellectual property right relating to any combination, machine, or process in which TI products or services are used. Information published by TI regarding third-party products or services does not constitute a license from TI to use such products or services or a warranty or endorsement thereof. Use of such information may require a license from a third party under the patents or other intellectual property of the third party, or a license from TI under the patents or other intellectual property of TI.

Reproduction of information in TI data books or data sheets is permissible only if reproduction is without alteration and is accompanied by all associated warranties, conditions, limitations, and notices. Reproduction of this information with alteration is an unfair and deceptive business practice. TI is not responsible or liable for such altered documentation.

Resale of TI products or services with statements different from or beyond the parameters stated by TI for that product or service voids all express and any implied warranties for the associated TI product or service and is an unfair and deceptive business practice. TI is not responsible or liable for any such statements.

Following are URLs where you can obtain information on other Texas Instruments products and application solutions:

Products		Applications	
Amplifiers	amplifier.ti.com	Audio	www.ti.com/audio
Data Converters	dataconverter.ti.com	Automotive	www.ti.com/automotive
DSP	dsp.ti.com	Broadband	www.ti.com/broadband
Interface	interface.ti.com	Digital Control	www.ti.com/digitalcontrol
Logic	logic.ti.com	Military	www.ti.com/military
Power Mgmt	power.ti.com	Optical Networking	www.ti.com/opticalnetwork
Microcontrollers	microcontroller.ti.com	Security	www.ti.com/security
		Telephony	www.ti.com/telephony
		Video & Imaging	www.ti.com/video
		Wireless	www.ti.com/wireless

Mailing Address: Texas Instruments
Post Office Box 655303 Dallas, Texas 75265