

REVISIONS					
P	LTR	DESCRIPTION	DATE	DMN	APVD
L		REVISED PER ECO-17-012525	01SEP2017	SY	SY

- 1 GOLD PLATE .00076 [.000030] MIN. THICK.
- 2 NICKEL PL. .00127[.000050] MIN. THK. PER QQ-N-290
- 3 SOLDER PL. .00254[.000100] MIN. THK.
- 4 STAMPED P/N & DATE CODE.
- 5. OPTIONAL: KEYING PLUG FOR INTERCONTACT KEYING IS 118982-1
- 6. OPTIONAL: CARD GUIDE (BASE NO 117169)
- 7 ALL PARTS ASSEMBLED IN CHINA MUST BE STAMPED "ASSY IN CHINA". THE WORD "CHINA" CAN BE SUBSTITUTED ONLY WHERE PART SIZE PROHIBITS STAMPING "ASSY IN CHINA", INK COLOR WHITE PER 115-9009, APPROX WHERE SHOWN, SIDE OPTIONAL.
- 8 ACTION PIN REQUIRES 2.13[.084] MIN. THK. PC BOARD.

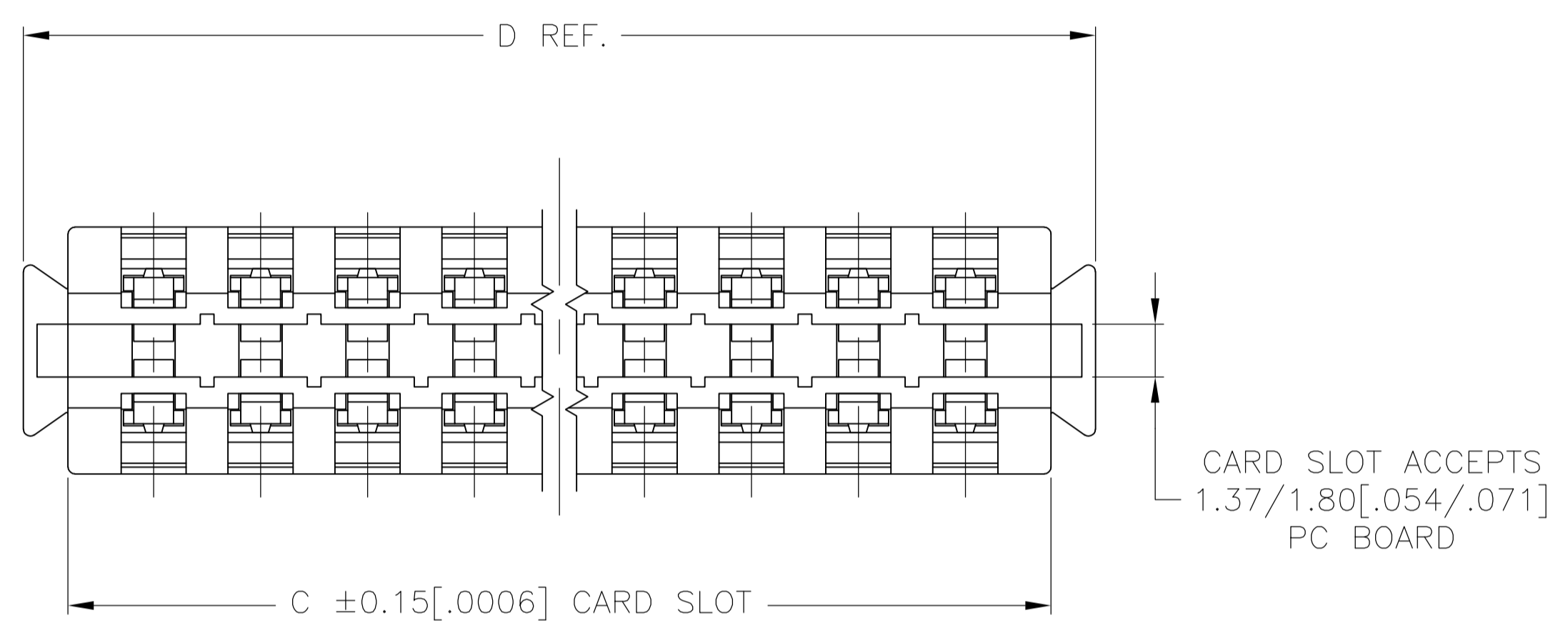

REQ'D DRILL SIZE	HOLE DIA ±.03[.001]	PLATING THICKNESS		HOLE DIAMETER		COPPER HARDNESS (KNOOP)	PAD DIA MIN.
		COPPER	TIN/LEAD	AFTER PLATING	AFTER REFLOW		
1.15mm	1.15 [.0453]	0.03-0.08 [.001-.003]	0.008 MIN. [.0003] MIN.	0.94-1.09 [.037-.043]	0.914-1.09 [.0036-.043]	150 MAX	1.57 [.062]
1.15mm	1.15 [.0453]	NOT PLATED THRU					1.65 [.065]

- 9 MATTE TIN PL. .00254[.000100] MIN. THK.
- 10 OBSOLETE PARTS: OBSOLETE CIS STREAMLINING PER D.RENAUD/D.SINISI

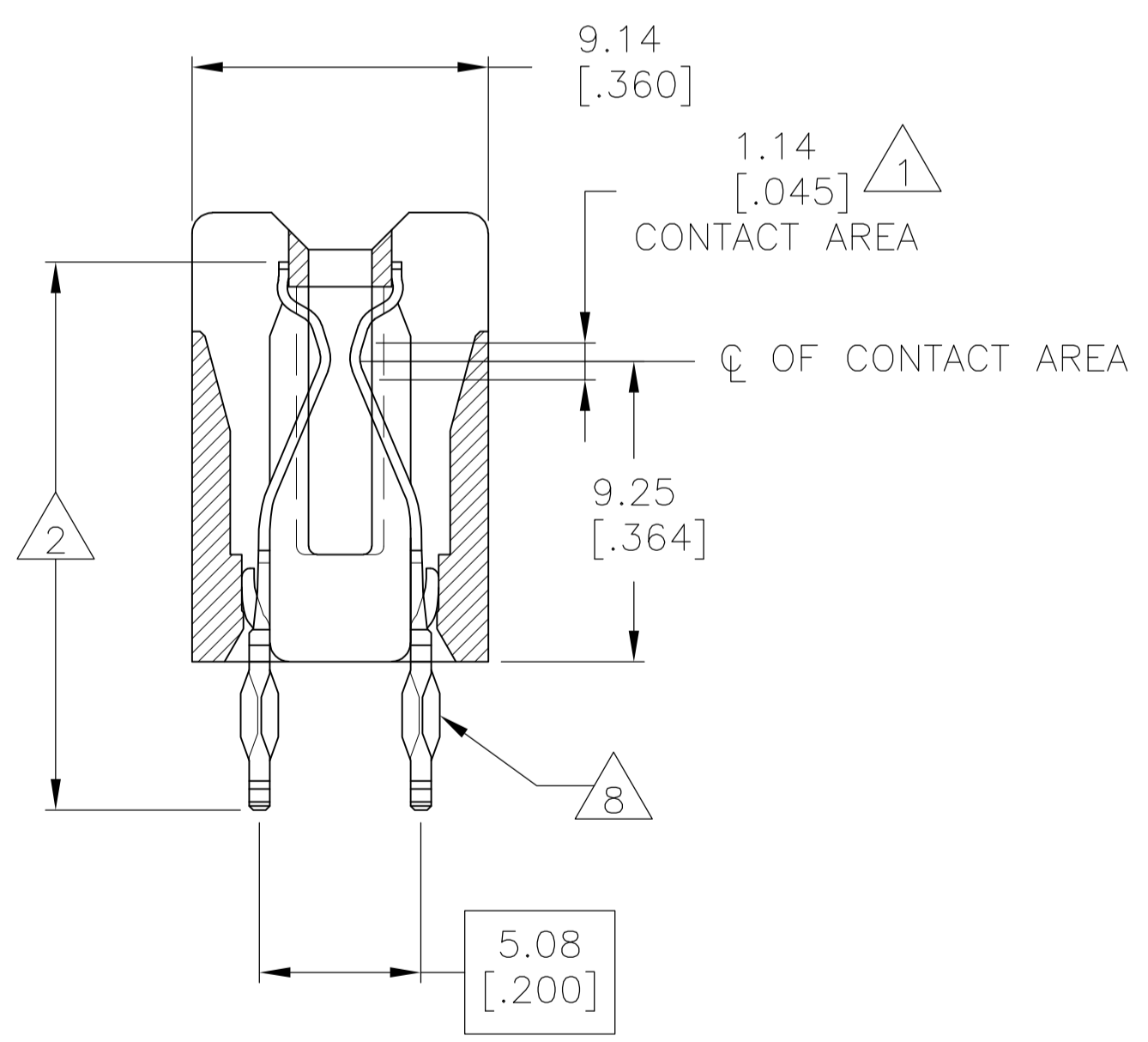
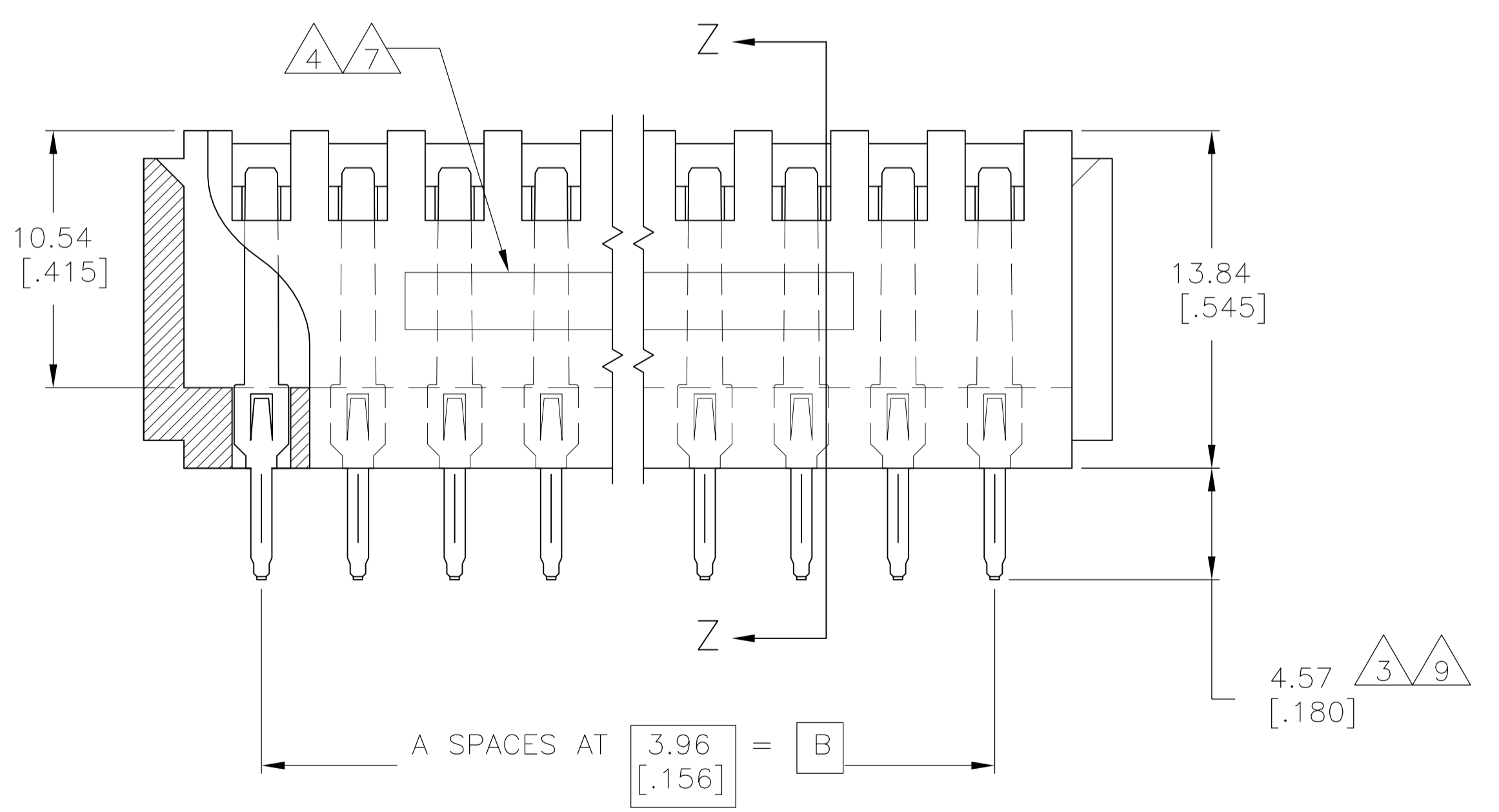

9/10	OBSOLETE	-177.65 [6.994]	-174.35 [6.864]	-166.42 [6.552]	-42	-43	-7-119790-9
9/10	118.21 [4.654]	114.91 [4.524]	106.98 [4.212]	27	28	6-119790-4	
9/10	94.44 [3.718]	91.13 [3.588]	83.21 [3.276]	21	22	5-119790-8	
9/10	OBSOLETE -66.70 [2.626]	OBSOLETE -63.40 [2.496]	OBSOLETE -55.47 [2.184]	-14	-15	-5-119790-1	
9/10	OBSOLETE -177.65 [6.994]	OBSOLETE -174.35 [6.864]	OBSOLETE -166.42 [6.552]	-42	-43	2-119790-9	
						2-119790-8	
						2-119790-7	
						2-119790-6	
						2-119790-5	
						2-119790-4	
						2-119790-3	
						2-119790-2	
						2-119790-1	
						2-119790-0	
						1-119790-9	
						1-119790-8	
						1-119790-7	
						1-119790-6	
						1-119790-5	
						1-119790-4	
						1-119790-3	
						1-119790-2	
						1-119790-1	
						1-119790-0	
						119790-9	
						119790-8	
						119790-7	
						119790-6	
						119790-5	
						119790-4	
						119790-3	
						119790-2	
						119790-1	
10	OBSOLETE	-66.70 [2.626]	-63.40 [2.496]	-55.47 [2.184]	-14	-15	119790-1

THIS DRAWING IS A CONTROLLED DOCUMENT. DIMENSIONS: mm [INCHES]. TOLERANCES UNLESS OTHERWISE SPECIFIED: 0 PLC ± -, 1 PLC ± -, 2 PLC ± -, 3 PLC ± 0.25[.010], 4 PLC ± -, ANGLES ± -.

MATERIAL: HOUSING: VALOX 420 SED, BLACK; CONTACTS: COPPER NICKEL. FINISH: 1 2 3 9.

APPROVED: R. L. LEHR (10-FEB-93), H. ROSE (7/8/94), H. ROSE (7/8/94). NAME: CONNECTOR, AMP PACE .156 X .200. APPLICATION SPEC: -. SIZE: A1. WEIGHT: 0.000000. CUSTOMER DRAWING.

STE TE Connectivity. SCALE: 4:1. SHEET: 1 OF 1. REV: L.