

POWERHOUSE**TWO**

Technical Specification

XP Alkaline Manganese Dioxide Battery



Power XP Alkaline

PH-9V-XP

Powerhouse Two Inc.
120 West Crown Point Road
Suite 112
Winter Garden, FL 34787

PH 407-654-5451

Fax 407-654-2795

www.PowerHB.com
gregg.haltzman@PowerHB.com

POWERHOUSE TWO



1. Scope

This specification is applicable to Powerhouse Two's XP Super Alkaline Battery.

1.1 Designations

PH-9V-XP 6LR61 6AM6 9V

1.2 Reference Document

IEC 60086-1 (2006-12) – Primary Batteries – Part 1: General
IEC 60086-2 (2006-12) – Primary Batteries – Part 2: Physical and Electrical Specifications

1.3 Execution standard

GB 8897.2 2012

2. Chemical System Zinc Manganese Dioxide

- Potassium Hydroxide Electrolyte

3. Heavy metal content (% per cell)

Hg < 0.0001 Cd < 0.0005 Pb < 0.0001

4. Nominal Voltage 9 volt

5. Average Weight 45g

POWERHOUSE TWO



6. Nominal Capacity 580 mAh

Condition: Continuous discharge at $20 \pm 2^\circ \text{C}$, $60 \pm 15\% \text{ RH}$, under 620Ω resistance –
2 hours per day to EPV 5.4 V.

7. Electrical Characteristics

Test Conditions: Tested within 30 days after delivery

Load resistance: $5.0 \text{ ohms} \pm 0.5\%$

Temperature: $20 \pm 2^\circ \text{C}$

Measuring time: 0.3 seconds

	Off-Load Voltage OCV (V)	Test Specification
New Battery	9.5	MIL-STD-105E Class II Double Sampling, AQL=0.4
After 3 months at Temp. 45°-C	9.2	
After 12 months at Room temperature	9.3	

8. Service Output

Temperature: 20 ± 2 degrees C

RH: $60 \pm 15\%$

Discharge Method			Minimum Average Duration			Minimum Capacity
Load Resistance	Time	Cutoff Voltage	Initial (MAD)	45°C for 3 months (MAD)	Normal Temperature for 12 months	Initial (MAD)
620Ω	2 Hr. / Day	5.4	50 Hours	47 Hours	47 Hours	610 mAh
270Ω	1 Hr. / Day	5.4	22 Hours	20 Hours	20 Hours	590 mAh



Acceptance Criteria

1. Nine (9) pieces of battery product will be tested for each discharging standard
2. The result of the average discharging time from each discharging standard shall be equal to or more than the average minimum time requirement: and no more than one battery has a service output less than 80% of the specified requirement.
3. One re-test is allowed to confirm the previous result

9. Electrolyte Leakage Proof Characteristics

Item	Condition	Period	Requirements	Acceptance Standard
Over-discharge Characteristics	20 Ω Load resistor Storage Temp – 20 \pm 2 ° C Relative Humidity 60 \pm 15% RH Time 24 Hours / day	48 Hrs.	There shall be no deformation exceeding the specified dimensions, nor leakage recognized by the human eye.	N=90 Ac=0 Re=1
High Heat and Humidity Test	Storage Temp 60 \pm 2° C Relative Humidity 90 \pm 5% RH	30 Days		N=10 Ac=0 Re=1

10. Marking

The following markings will be printed, stamped, or impressed on the body of the battery.

- | | |
|----------------|--|
| 1. Designation | PH-9V-XP Alkaline |
| 2. Polarity | “+” & “-”
Located on cathode can |
| 3. Others | 3.1 9V 6LR61 6AM6 9V
3.2 Made in China
3.3 Marking of separate collection (Logo) |
| 4. Warning | Do not dispose of in fire, recharge, put in backwards, or mix with used or other battery types. May explode or leak and cause personal injury. |



11. Caution for Use

1. Since the battery is not manufactured for recharging, there are risks of electrolyte leakage causing damage to the device if the battery is recharged.
2. The battery shall be installed with its “+” and “-” polarity in the correct position, otherwise it might cause a short circuit.
3. Short circuiting, heating, or disposing into fire and disassembling is prohibited.
4. Battery cannot be subjected to a forced discharge, which can lead to internal gas generation which may result in bulging, leakage, and de-crimping of cap.
5. New and used batteries cannot be used at the same time. When replacing batteries, replace all batteries together with the same type.
6. Exhausted batteries should be removed from compartment to prevent over-discharge, which causes leakage and damage to the device
7. Direct soldering will cause damage to the battery
8. Battery should be kept out of the reach of children to prevent swallowing. In case of accident, contact physician immediately.
9. The battery should never be dismantled or deformed.
10. Recommend storage under $20 \pm 2^{\circ}\text{C}$ and relative Humidity of $65 \pm 20\%$.



12. Shelf Life

5 Years after delivery under proper storage conditions. (80% original charge)

Storage Conditions

Temperature $20 \pm 2^\circ \text{C}$

Relative Humidity $65 \pm 20\% \text{RH}$

13. Discharge Curves

Fig. 1 Test Temperature - $20 \pm 2^\circ \text{C}$
Discharge Method – 620Ω 2 hr/day

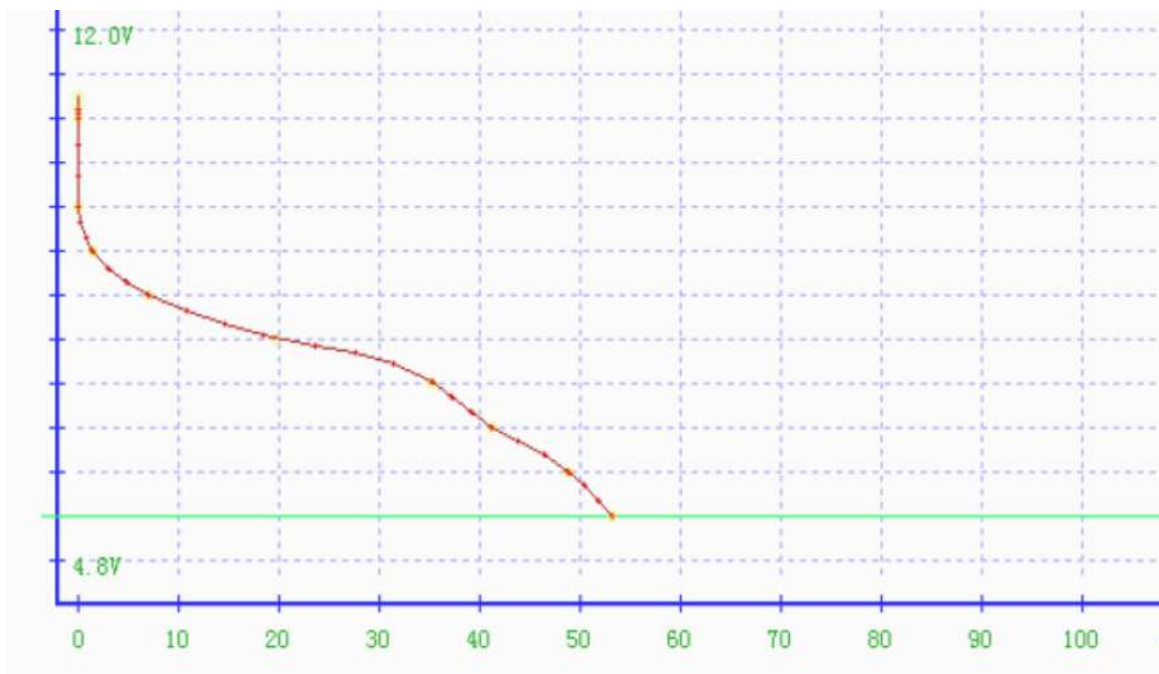

14. Compliance & Environmental Information

This product complies with the EU RoHS Directive 2002/95/EC and Battery Directive 2006/66/EC and meets all US standards set by the EPA for Alkaline Manganese batteries. MSDS available upon request.

15. Battery Dimension

PH-9V-XP Battery Dimensions and Structure

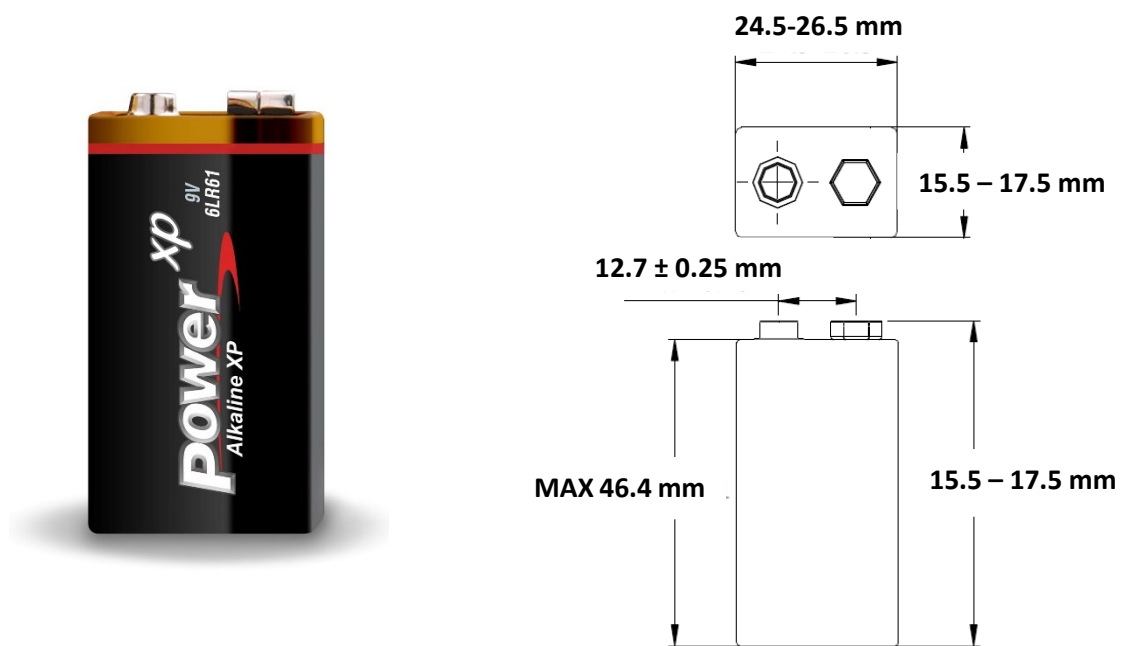

Powerhouse Two Inc.		
Model: PH-9V-XP	Drawing number: DWG-S-006	
Scale: NTS	Dim: mm	Approved by:
Date: 04/06/2020	Drawn by: Kelvin	G. Halteman - C. Chu
Tolerances: Linear ± 1 Angular $\pm \frac{1}{4}$ 3 rd angle projection		