

Features

- Integral TTL Driver
- Isolation: 50 dB Typ. At 1 GHz
- Ultra Low DC Power Consumption
- Hermetic Surface Mount Package
- 50 Ohms Nominal Impedance
- MIL-STD-883 Screening Available
- Lead-Free CR-14 Package
- 260°C Reflow Compatible
- RoHS* Compliant

Description

M/A-COM's SW-314-PIN is a GaAs MMIC SP4T absorptive switch with an integral silicon ASIC driver. This device is in a 24-lead ceramic surface mount package. These switches exhibit excellent performance from DC to 3 GHz, with very low DC power dissipation. The SW-314-PIN is ideally suited for RF/IF communications applications. Environmental screening is available. Contact the factory for information.

Ordering Information

Part Number	Package
SW-314-PIN	Bulk Packaging
SW-314-TB	Sample Test Board

Note: Reference Application Note M513 for reel size information.

Functional Block Diagram

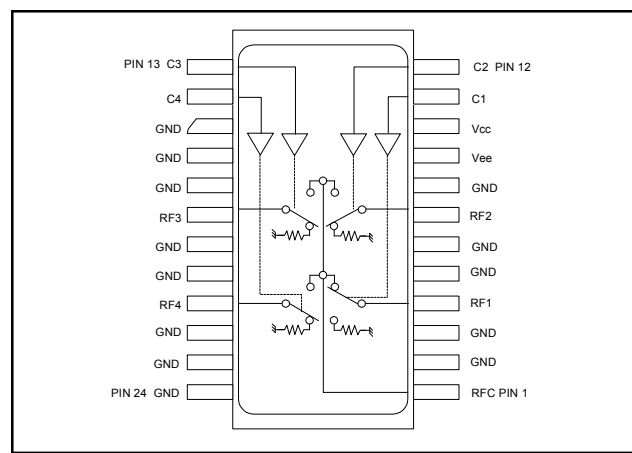

Pin Configuration

Pin No.	Function	Pin No.	Function
1	RFC	13	C3
2	GND	14	C4
3	GND	15	GND
4	RF1	16	GND
5	GND	17	GND
6	GND	18	RF3
7	RF2	19	GND
8	GND	20	GND
9	Vee	21	RF4
10	Vcc	22	GND
11	C1	23	GND
12	C2	24	GND

The metal bottom of the case must be connected to RF and DC ground.

* Restrictions on Hazardous Substances, European Union Directive 2002/95/EC.

Electrical Specifications: (From -55°C to $+85^{\circ}\text{C}$), $Z_0 = 50\Omega$ ^{1,2}

Parameter	Test Conditions	Frequency	Units	Min	Typ	Max
Insertion Loss	—	DC - 0.5 GHz	dB	—	—	1.3
		DC - 1.0 GHz	dB	—	—	1.4
		DC - 2.0 GHz	dB	—	—	1.6
		DC - 3.0 GHz	dB	—	—	1.8
Isolation	—	DC - 0.5 GHz	dB	50	—	—
		DC - 1.0 GHz	dB	40	—	—
		DC - 2.0 GHz	dB	35	—	—
		DC - 3.0 GHz	dB	30	—	—
VSWR	RFC, RF1 - RF4 (On)	DC - 0.5 GHz	Ratio	—	—	1.6:1
		DC - 1.0 GHz	Ratio	—	—	1.6:1
		DC - 2.0 GHz	Ratio	—	—	1.6:1
		DC - 3.0 GHz	Ratio	—	—	1.8:1
VSWR	RF1 - RF4 (Off)	DC - 0.5 GHz	Ratio	—	—	1.3:1
		DC - 1.0 GHz	Ratio	—	—	1.5:1
		DC - 2.0 GHz	Ratio	—	—	1.9:1
		DC - 3.0 GHz	Ratio	—	—	2.4:1
Trise, Tfall	10% to 90%	—	ns	—	7	—
Ton, Toff	50% Control to 90% / 10% RF	—	ns	—	25	—
Transients	In-Band (peak-peak)	—	mV	—	20	—
1 dB Compression	Input Power	0.05 GHz	dBm	—	+20	—
		0.5 GHz to 3 GHz	dBm	—	+27	—
IP3	Two-Tone Input Power up to +5 dBm	0.05 GHz	dBm	—	+35	—
		0.5 GHz to 3 GHz	dBm	—	+46	—
IP2	Two-Tone Input Power up to +5 dBm	0.05 GHz	dBm	—	+45	—
		0.5 GHz to 3 GHz	dBm	—	+60	—
Vcc	—	—	V	4.5	5.0	5.5
Vee	—	—	V	-8.0	—	-5.0
Icc	Vcc = 4.5 to 5.5 V Vctl = 0 to 0.8V, or Vcc -2.1V to Vcc	—	mA	—	0.2	4.0
Iee	Vee = -5.0V to -8.0V	—	mA	—	0.1	1.0
Vctl Vctf	Logic 0 (TTL)	—	V	0.0	—	0.8
	Logic 1 (TTL)	—	V	2.0	—	5.0
Input Leakage Current (Low)	0 to 0.8V	—	μA	—	—	1.0
Input Leakage Current (High)	2.0 to 5.0V	—	μA	—	—	1.0

1. All specifications apply when operated with bias voltages of +5V for Vcc and -5V for Vee.
2. When DC blocks are used, a 10K ohm return to GND is required on the RFC port.

Absolute Maximum Ratings ^{3,4}

Parameter	Absolute Maximum
Max Input Power 0.05 GHz 0.5 - 3.0 GHz ⁵	+27 dBm +34 dBm
V_{CC}	$-0.5V \leq V_{CC} \leq +7.0V$
V_{EE}	$-8.5V \leq V_{EE} \leq +0.5V$
$V_{CC} - V_{EE}$	$-0.5V \leq V_{CC} - V_{EE} \leq 14.5V$
V_{in}^5	$-0.5V \leq V_{in} \leq V_{CC} + 0.5V$
Operating Temperature	-55°C to +125°C
Storage Temperature	-65°C to +150°C

- Exceeding any one or combination of these limits may cause permanent damage to this device.
- M/A-COM does not recommend sustained operation near these survivability limits.
- When the input power is applied to the terminated port, the absolute maximum is +30 dBm.
- Standard CMOS TTL interface, latch-up will occur if logic signal is applied prior to power supply.

Handling Procedures

Please observe the following precautions to avoid damage:

Static Sensitivity

Gallium Arsenide Integrated Circuits are sensitive to electrostatic discharge (ESD) and can be damaged by static electricity. Proper ESD control techniques should be used when handling these devices.

Typical Performance Curves

Insertion Loss vs. Frequency

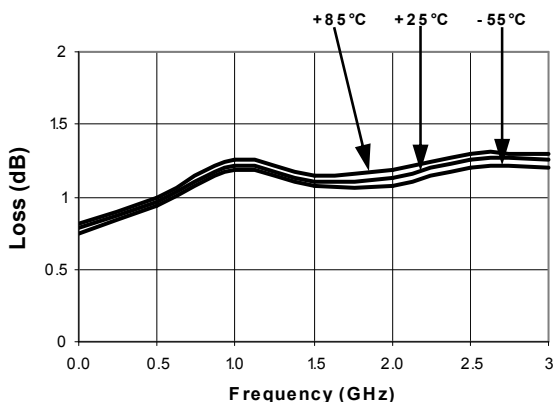

Recommended PCB Configuration

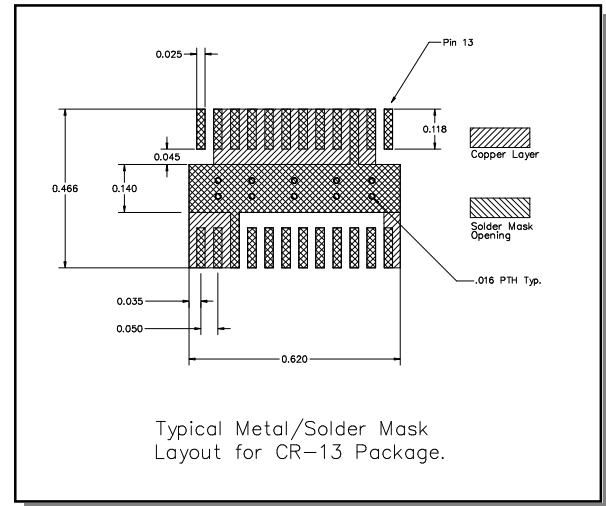

Truth Table (Switch)

TTL Control Inputs				Condition of Switch			
				RF Common to Each RF Port			
C1	C2	C3	C4	RF1	RF2	RF3	RF4
1	0	0	0	On	Off	Off	Off
0	1	0	0	Off	On	Off	Off
0	0	1	0	Off	Off	On	Off
0	0	0	1	Off	Off	Off	On

0 = TTL Low; 1 = TTL High

Isolation vs. Frequency

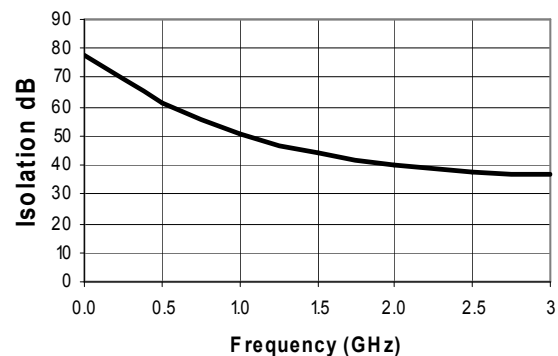

ADVANCED: Data Sheets contain information regarding a product M/A-COM is considering for development. Performance is based on target specifications, simulated results, and/or prototype measurements. Commitment to develop is not guaranteed.

PRELIMINARY: Data Sheets contain information regarding a product M/A-COM has under development. Performance is based on engineering tests. Specifications are typical. Mechanical outline has been fixed. Engineering samples and/or test data may be available. Commitment to produce in volume is not guaranteed.

- North America** Tel: 800.366.2266 / Fax: 978.366.2266
- Europe** Tel: 44.1908.574.200 / Fax: 44.1908.574.300
- Asia/Pacific** Tel: 81.44.844.8296 / Fax: 81.44.844.8298

Visit www.macom.com for additional data sheets and product information.

M/A-COM Inc. and its affiliates reserve the right to make changes to the product(s) or information contained herein without notice.

Typical Performance Curves

VSWR vs. Frequency

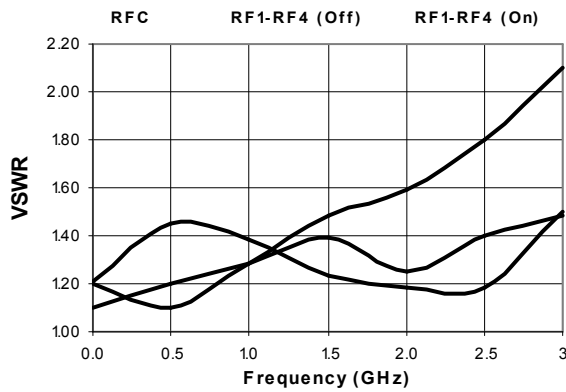

Lead-Free, CR-14 Ceramic Package[†]

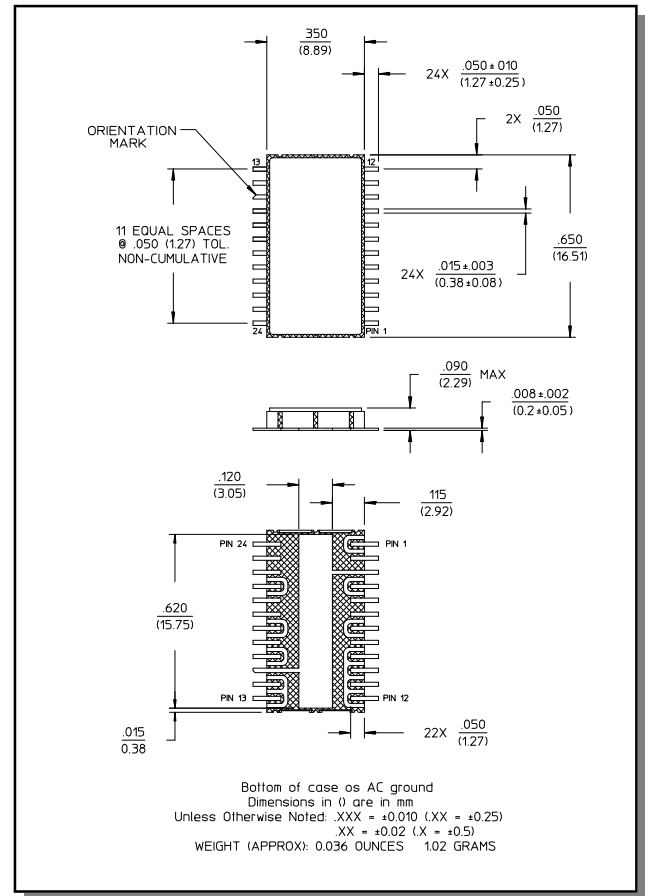

[†] Reference Application Note M538 for lead-free solder reflow recommendations.