

GW/ ...E/...DB9

Universal device servers and protocol converters



Data sheet
3750_en_A

© PHOENIX CONTACT 2017-04-12

1 Description

The Phoenix Contact family of Ethernet protocol converters and device servers provides a simple way to migrate legacy serial devices and buses to modern Ethernet networks. Variants are available with one, two, or four D-SUB 9 serial ports and one or two RJ45 Ethernet ports.

Start-up and configuration are simple using an embedded web server, and communication is kept secure with 256-bit AES encryption and optional authentication. With a wide operating temperature range (-40 to +70°C) and hazardous area approvals, the devices are suitable for use in any industry.

The most common industrial protocols are supported, with various combinations of RAW/ASCII serial data, Modbus® RTU, TCP/IP, Modbus TCP, and EtherNet/IP™ technology.

2 Features

- 256-bit AES encryption for secure transfer of sensitive data
- Web-based management (WBM) configuration
- Comprehensive diagnostics for fast and easy troubleshooting
- Compact DIN rail-mount form factor
- COM port redirector software and Windows® operating system COM port drivers



Make sure you always use the latest documentation. It can be downloaded at phoenixcontact.net/products.



This document is valid for all products listed in the "Ordering data" on page 3

3 Selection guide

A variety of different protocol converters and device servers are available in four different port combinations.

Serial ports (D-SUB 9)	Ethernet ports (RJ45)
one	one
two	one
two	two
four	two

The serial ports are universal RS-232/422/485.

Device server

The GW/ DEVICE/ SERVER... devices migrate legacy serial devices to modern Ethernet networks. With the aid of virtual communication ports, existing application software that only support serial communication can be redirected to the network card of a computer with a Windows® operating system.

The COM Port redirector software, as well as a Windows driver, is available for integration with a PC application free of charge.

Modbus RTU to Modbus TCP

The GW/ MODBUS/ TCP/RTU... devices are used to convert serial-based Modbus RTU (or ASCII) to Modbus

TCP. These modules are extremely powerful and can be configured to almost any combination of Modbus client and server, including a shared memory configuration, allowing two Modbus masters (servers) to communicate with each other. Device ID aliasing is also supported to create a “virtual” Modbus ID for Modbus devices that do not have configurable Modbus addresses.

ASCII to Modbus TCP

The GW/ MODBUS/ TCP/ASCII... modules are used to convert RAW or ASCII serial strings from devices such as barcode scanners, weigh scales, or RFID tags into Modbus registers. Filtering rules may be created in the modules in order to mask start and stop delimiters of a bar code, for example, to simplify integration into a programmable controller.

ASCII to EtherNet/IP™

The GW/ EIP/ASCII... modules are used to convert RAW or ASCII serial strings from devices such as barcode scanners, weigh scales, or RFID tags into EtherNet/IP. Filtering rules may be created in the modules in order to mask start and stop delimiters of a bar code, for example, to simplify integration into a programmable controller.

Device A	Device B				
	Modbus TCP master	Modbus RTU master	Modbus ASCII master	Encapsulated TCP/IP	EtherNet/IP
Modbus RTU slave	GW/ MODBUS/ TCP/ RTU...	GW/ MODBUS/ TCP/ RTU...	GW/ MODBUS/ TCP/ RTU...	GW/ DEVICE/ SERVER... GW/ MODBUS/ TCP/ RTU...	
Modbus ASCII slave	GW/ MODBUS/ TCP/ RTU...	GW/ MODBUS/ TCP/ RTU...	GW/ MODBUS/ TCP/ RTU...	GW/ DEVICE/ SERVER... GW/ MODBUS/ TCP/ RTU...	
Modbus RTU master	GW/ MODBUS/ TCP/ RTU...	GW/ MODBUS/ TCP/ RTU...	GW/ MODBUS/ TCP/ RTU...	GW/ DEVICE/ SERVER... GW/ MODBUS/ TCP/ RTU...	
Modbus ASCII master	GW/ MODBUS/ TCP/ RTU...	GW/ MODBUS/ TCP/ RTU...	GW/ MODBUS/ TCP/ RTU...	GW/ DEVICE/ SERVER... GW/ MODBUS/ TCP/ RTU...	
Modbus TCP master	GW/ MODBUS/ TCP/ RTU...	GW/ MODBUS/ TCP/ RTU...	GW/ MODBUS/ TCP/ RTU...	–	
Modbus TCP slave	GW/ MODBUS/ TCP/ RTU...	GW/ MODBUS/ TCP/ RTU...	GW/ MODBUS/ TCP/ RTU...	–	
Serial RAW/ASCII	GW/ MODBUS/ TCP/ ASCII...	GW/ MODBUS/ TCP/ ASCII...	GW/ MODBUS/ TCP/ ASCII...	GW/ DEVICE/ SERVER...	GW/ EIP/ASCII...
Ethernet RAW/ASCII	GW/ MODBUS/ TCP/ ASCII...	GW/ MODBUS/ TCP/ ASCII...	GW/ MODBUS/ TCP/ ASCII...	–	GW/ EIP/ASCII...

4 Ordering data

Products

Description	Type	Order No.	Pcs./Pkt.
Serial device server for converting serial data (RS-232/422/485) to Ethernet data (RJ45). Supports TCP and UDP protocols. COM port redirector software and Windows drivers are available for download. Includes one RJ45 port and one D-SUB 9 port.	GW DEVICE SERVER 1E/1DB9	2702758	1
Serial device server for converting serial data (RS-232/422/485) to Ethernet data (RJ45). Supports TCP and UDP protocols. COM port redirector software and Windows drivers are available for download. Includes one RJ45 port and two D-SUB 9 ports.	GW DEVICE SERVER 1E/2DB9	2702760	1
Serial device server for converting serial data (RS-232/422/485) to Ethernet data (RJ45). Supports TCP and UDP protocols. COM port redirector software and Windows drivers are available for download. Includes two RJ45 port and two D-SUB 9 ports.	GW DEVICE SERVER 2E/2DB9	2702761	1
Serial device server for converting serial data (RS-232/422/485) to Ethernet data (RJ45). Supports TCP and UDP protocols. COM port redirector software and Windows drivers are available for download. Includes two RJ45 ports and four D-SUB 9 ports.	GW DEVICE SERVER 2E/4DB9	2702763	1
The GW MODBUS TCP/RTU... gateway converts serial based Modbus RTU (or ASCII) to Modbus TCP. Supports serial master or slave devices. Includes one RJ45 port and one D-SUB 9 port.	GW MODBUS TCP/RTU 1E/1DB9	2702764	1
The GW MODBUS TCP/RTU... gateway converts serial based Modbus RTU (or ASCII) to Modbus TCP. Supports serial master or slave devices. Includes one RJ45 port and two D-SUB 9 ports.	GW MODBUS TCP/RTU 1E/2DB9	2702765	1
The GW MODBUS TCP/RTU... gateway converts serial based Modbus RTU (or ASCII) to Modbus TCP. Supports serial master or slave devices. Includes two RJ45 ports and two D-SUB 9 ports.	GW MODBUS TCP/RTU 2E/2DB9	2702766	1
The GW MODBUS TCP/RTU... gateway converts serial based Modbus RTU (or ASCII) to Modbus TCP. Supports serial master or slave devices. Includes two RJ45 ports and four D-SUB 9 ports.	GW MODBUS TCP/RTU 2E/4DB9	2702767	1
The GW MODBUS TCP/ASCII... converts RAW or ASCII serial strings into Modbus registers. Includes one RJ45 port and one D-SUB 9 port.	GW MODBUS TCP/ASCII 1E/1DB9	2702768	1
The GW MODBUS TCP/ASCII... converts RAW or ASCII serial strings into Modbus registers. Includes one RJ45 port and two D-SUB 9 ports.	GW MODBUS TCP/ASCII 1E/2DB9	2702769	1
The GW MODBUS TCP/ASCII... converts RAW or ASCII serial strings into Modbus registers. Includes two RJ45 ports and two D-SUB 9 ports.	GW MODBUS TCP/ASCII 2E/2DB9	2702770	1
The GW MODBUS TCP/ASCII... converts RAW or ASCII serial strings into Modbus registers. Includes two RJ45 ports and four D-SUB 9 ports.	GW MODBUS TCP/ASCII 2E/4DB9	2702771	1
The GW EIP/ASCII... converts RAW or ASCII serial strings into EtherNet/IP™ protocol. Includes one RJ45 port and one D-SUB 9 port.	GW EIP/ASCII 1E/1DB9	2702772	1
The GW EIP/ASCII... converts RAW or ASCII serial strings into EtherNet/IP™ protocol. Includes one RJ45 port and two D-SUB 9 ports.	GW EIP/ASCII 1E/2DB9	2702773	1
The GW EIP/ASCII... converts RAW or ASCII serial strings into EtherNet/IP™ protocol. Includes two RJ45 ports and two D-SUB 9 ports.	GW EIP/ASCII 2E/2DB9	2702774	1
The GW EIP/ASCII... converts RAW or ASCII serial strings into EtherNet/IP™ protocol. Includes two RJ45 ports and four D-SUB 9 ports.	GW EIP/ASCII 2E/4DB9	2702776	1

Accessories

Description	Type	Order No.	Pcs./Pkt.
RS-232 cable, D-SUB 9 socket on D-SUB 9 socket, 9-wire, 1:1	PSM-KA9SUB9/BB/2METER	2799474	1
Patch cable, CAT5, assembled, 0.5 m	FL CAT5 PATCH 0,5	2832263	1
Patch cable, CAT5, assembled, 5 m	FL CAT5 PATCH 5,0	2832580	1
D-SUB 9 female connector, one cable entry <35°, universal type for all systems, pin assignment: 1, 2, 3, 4, 5, 6, 7, 8, 9 to screw connection terminal block	SUBCON 9/F-SH	2761499	1
D-SUB 9 female connector, axial version with two cable entries, universal type for all systems, pin assignment: 1, 2, 3, 4, 5, 6, 7, 8, 9 to screw connection terminal block	SUBCON-PLUS-F/AX 9	2311797	1
D-SUB 9 female connector, two cable entries < 35°, universal type for all systems, pin assignment: 1, 2, 3, 4, 5, 6, 7, 8, 9 to one screw connection terminal block	SUBCON-PLUS 9/F	2744241	1
D-SUB 9 female connector, two cable entries < 35°, bus system: CAN, SUCONET K1, K2 (MOELLER), S-BUS (Saia), J-BUS (Merlin Gerin), pin assignment: 2, 3, 4, 5, 7, 9 to two screw connection terminal blocks	SUBCON-PLUS F2	2799490	1
V.24 (RS-232) zero modem connector	PSM-AD-D9-NULMODEM	2708753	1
Surge protection in accordance with Class EA (CAT6A), for Gigabit Ethernet (up to 10 Gbps), token ring, FDDI/CDDI, ISDN, and DS1. Suitable for Power over Ethernet (PoE+) "Mode A" and "Mode B". RJ45 attachment plug with separate grounding cable and ground connection snap-on foot for NS 35 DIN rails.	DT-LAN-CAT.6+	2881007	1
Ethernet switch, five TP RJ45 ports, automatic detection of data transmission speed of 10 or 100 Mbps (RJ45), autocrossing function	FL SWITCH SFN 5TX	2891152	1

5 Technical data

General data

Temperature range, operating	-40 ... +70°C
Temperature range, storage/transport	-40 ... +80°C
Permissible humidity, operation	10 ... 95% non-condensing
Permissible humidity, storage/transport	5 ... 95% non-condensing
Degree of protection	IP20
Housing material	PA 6.6
Color	Gray
Mounting	NS 35 rail
Height	99 mm
Width	
GW ...1E/ ...DB9	22.5 mm
GW ...2E/ ...DB9	45 mm
Depth	115 mm

Electrical data

Supply voltage range	10.8 ... 30 V DC
Typical current consumption	
GW ...1E/1DB9	48 mA
GW ...1E/2DB9	76 mA
GW ...2E/2DB9	88 mA
GW ...2E/4DB9	110 mA
Maximum current consumption	
GW ...1E/1DB9	60 mA
GW ...1E/2DB9	85 mA
GW ...2E/2DB9	100 mA
GW ...2E/4DB9	120 mA

Connection data

Connector type	Removable
Connection method	Screw
Conductor cross section (solid/stranded/AWG)	0.2 ... 2.5 mm ² /0.2 ... 2.5 mm ² /24 ... 14
Stripping length	7 mm
Screw thread	M3
Wire-clamp screw torque	0.5 ... 0.6 Nm

Data interface

Ethernet type	10/100Base-T(X) per IEEE 802.3
Ethernet connection type	RJ45
Serial interface	RS-232/422/485
Serial connection type	D-SUB 9, male
Serial port transmission speeds	0.3; 0.6; 1.2; 2.4; 4.8; 9.6; 19.2; 38.4; 58.6; 115.2; 230.4 kbps
Termination	Software configurable, 120 Ω

Conformance

Electromagnetic compatibility	EMC Directive 2014/30/EU
Radio interference	EN 55022 EN 55024
Vibration	In accordance with IEC/EN 60068-2-6; 1g, 10 ... 150 Hz
Shock	In accordance with IEC/EN 60068-2-27; 15g, 11 ms
Noise emissions	EN 61000-6-4
Noise immunity	EN 61000-6-2:2005
EU conformance	CE-compliant

Approvals

UL	61010-1
UL	Class I, Div. 2, Groups A, B, C, D, T4

5.1 Block diagram

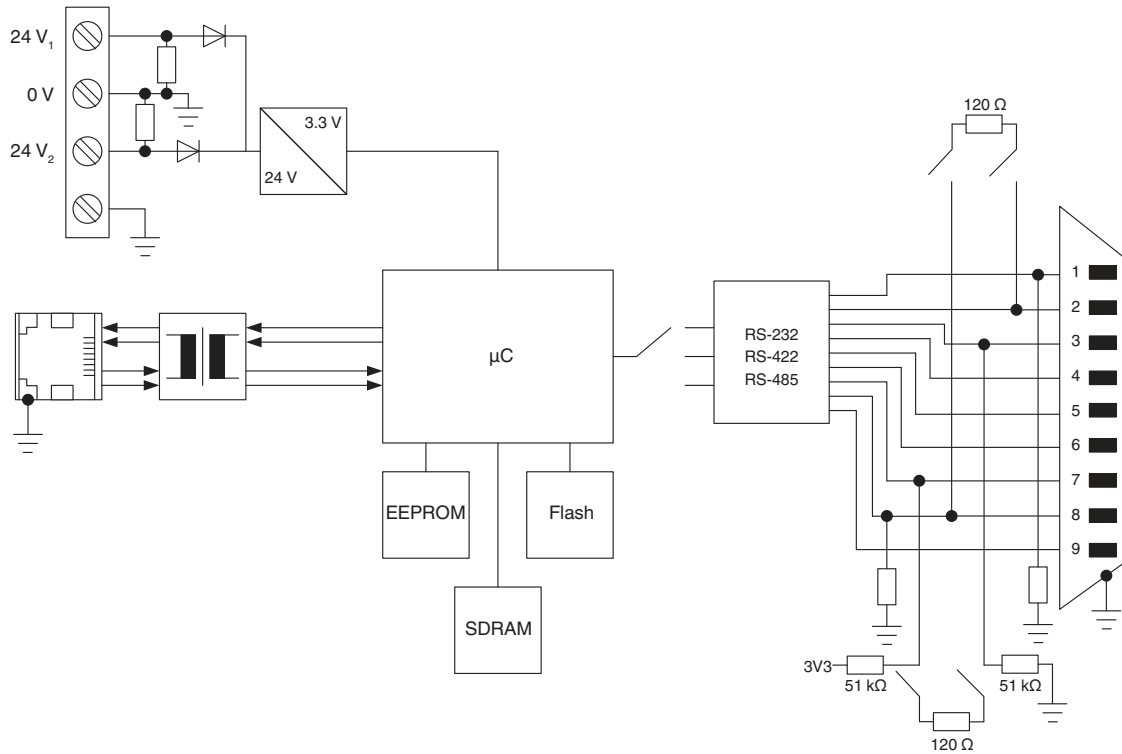
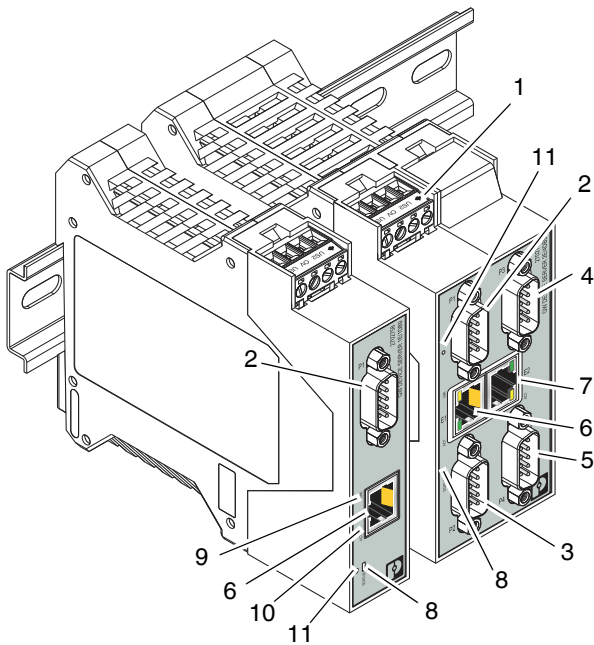

Figure 1 Block diagram

5.2 Structure



- 1 Power connector
- 2 D-SUB 9 connector, port 1 (P1)
- 3 D-SUB 9 connector, port 2 (P2)
- 4 D-SUB 9 connector, port 3 (P3)
- 5 D-SUB 9 connector, port 4 (P4)
- 6 Ethernet port, RJ45 (E1)
- 7 Ethernet port, RJ45 (E2)
- 8 Status LED
- 9 Ethernet activity status LED
- 10 Ethernet link status LED
- 11 Reset button

Figure 2 Structure



Figure 2 shows the GW...1E/1DB9 and GW.../2E/4DB9 variants. Other variants are similar.

6 Installation

6.1 LEDs

LED	Color	Meaning
STATUS	Green	The STATUS LED flashes while the device is booting (approximately 15 seconds). After booting, the LED blinks approximately every ten seconds. An internal error is indicated by three flashes every five seconds.
	Green	Link LED. On indicates Ethernet network is connected. ¹
	Yellow	Activity LED. Flashing indicates data transfer activity. ¹

¹ LEDs on Ethernet ports are not labeled.

6.2 Data interfaces

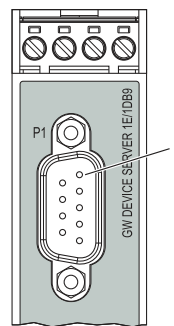

Figure 3 Pin 1 location

6.2.1 RS-232 interface



The V.24 (RS-232) interface of the GW/ ...E/ ...DB9 is a data terminal equipment (DTE) assignment.

The D-SUB 9 connector may function as an RS-232, RS-422, or RS-485 interface. The RS-232 interface is a data terminal equipment (DTE) device that behaves like a personal computer (PC). A null modem cable or adapter is required to connect to a PC.

Connect the GW/ ...E/...DB9 to the V.24 (RS-232) device to be connected (for example, a PC) by way of the PSM-KA-9SUB 9/BB/2 METER V.24 (RS-232) cable (Order No. 2799474). The cable is an interface cable with 1:1 connected contacts.

GW/ ...E/ ...DB9		End device			
Pin	RS-232	D-SUB 9 (DCE)	D-SUB 9 (DTE)	D-SUB 25 (DCE)	D-SUB 25 (DTE)
1	DCD	1	4	8	20
2	RxD	2	3	3	2
3	TxD	3	2	2	3
4	DTR	4	1, 6	20	6, 8
5	GND	5	5	7	7
6	DSR	6	4	6	20
7	RTS	7	8	4	5
8	CTS	8	7	5	4
9	RI	9	-	22	-

6.2.2 RS-422, RS-485 four-wire interface

Four-wire RS-422 and RS-485 supports full-duplex communication. Twisted-pair shielded cables, with the shields terminated at a common point, are recommended.

6.2.3 RS-485 interface

Two-wire RS-485 supports half-duplex communication. Twisted-pair shielded cables, with the shields terminated at a common point, are recommended.

GW/ ...E/...DB9			End device	
Pin	RS-422	RS-485	RS-422	RS-485
2	T(A)-	-	D(A)	-
3	D(A)-	D(A)-	T(A)	D(A)
5	GND	GND	GND	GND
7	D(B)+	D(B)+	T(B)	D(B)
8	T(B)+	-	D(B)	-

Termination resistors

Termination resistors must be activated on the first and last device in an application consisting of an RS-422 or a RS-485 network. The termination resistors are integrated into the GW/ ...E/...DB9 and can be switched on via the web-based management interface.

6.2.4 Ethernet interface

The GW ... has an Ethernet interface on the front in RJ45 format to which only twisted-pair cables with an impedance of 100 Ω can be connected. The data transmission rate is either 10 or 100 Mbps. The GW/ ...E/...DB9 supports the auto negotiation function for automatic selection of the transmission speed, as well as an automatic crossover feature for the automatic selection of line or crossover cabling.

If the GW... has two Ethernet ports, the GW/ ...E/...DB9 is classified as a switch. When using only one port, it is a simple end-node device. The maximum number of daisy-chained GW/ ...E/...DB9 units, and the maximum distance between units, is based on the Ethernet standard and will be determined by your own environment and the conformity of your network to these standards.

7 Startup and configuration

7.1 Web-based management

The user-friendly, web-based management (WBM) interface can manage GW/ ...E/...DB9 devices from anywhere in the network using a standard browser. Comprehensive configuration and diagnostic functions, including a wide range of information about the device itself, the current parameters, and the operating state, are clearly displayed on a graphical format.

The default network settings of the GW/ ...E/...DB9 are:

IP address: 192.168.254.254
Subnet mask: 255.255.255.0
Gateway: 0.0.0.0

Enter the credentials to access the WBM configuration pages. The default credentials are:

User name: Admin
Default password: admin

7.2 Resetting the device

If you need to reset the module to factory settings, there are two methods available.

7.2.1 Hardware reset

The reset button allows resetting the device without the use of a PC.

While connected to the power source:

1. Press and hold the reset button for at least three seconds. Reinitializing the module and firmware reset may take some time. Do not disconnect from power.
2. After a successful reset, the module will return to the factory default address (192.168.254.254).

7.2.2 Software reset

1. Start the WBM and navigate to the “Device Maintenance/Restore Defaults” page.
2. Click the “Check the box to confirm” check box on the page.
3. Click the “Apply Changes” button.
4. After a successful reset, the module will return to the factory default address (192.168.254.254).

8 Application examples

8.1 GW/ DEVICE/ SERVER...

Serial tunneling

A common application is simple point-to-point connection of two serial devices via an Ethernet network. The data is tunneled through the network using two GW/ DEVICE/ SERVER... modules, which removes any range restrictions, such as a maximum of 15 m for V.24 (RS-232). This connection also operates across sub-networks and gateways. Both GW/ DEVICE/ SERVER... modules are logically linked with one another by specifying the target and source IP addresses.

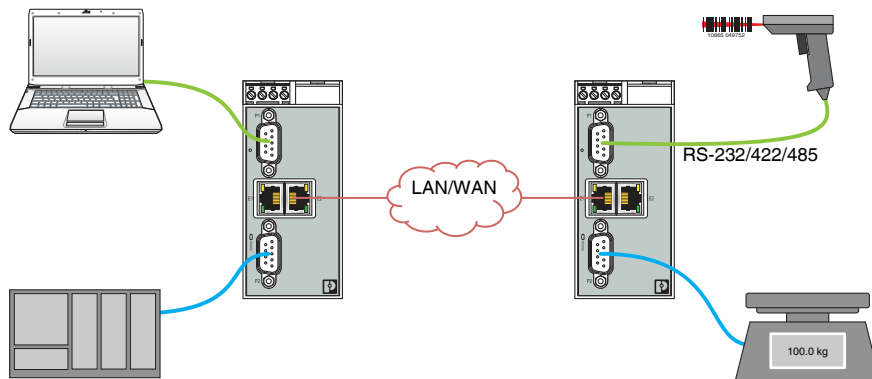

Figure 4 Serial tunneling

It is also possible to multiplex data from multiple serial ports on multiple GW/ DEVICE/ SERVER... modules to a single serial port on a GW/ DEVICE/ SERVER...

Virtual COM port

Existing application software that only communicates via serial COM interfaces can be redirected to remote COM ports. Virtual COM ports must be created on the PC that the software uses for communication. The virtual COM ports are physically redirected to the network card and a destination IP in the network. There are two options for creating virtual COM ports: the COM port redirector software, or the GW DEVICE SERVER... Windows driver. Both can be downloaded from phoenixcontact.com.

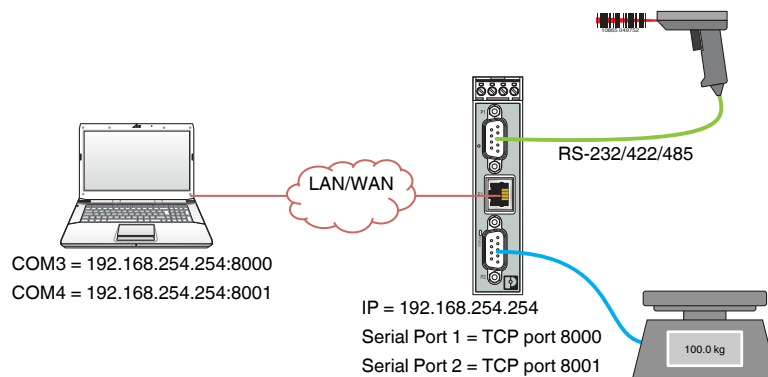

Figure 5 Virtual COM port

8.2 GW MODBUS TCP/ASCII...

The ASCII to Modbus TCP converters enable the integration of ASCII serial or TCP/IP barcode scanners, RFID readers, weigh scales, vision systems and encoders, etc., directly into a Modbus TCP control system. The ASCII strings are mapped into Modbus registers.

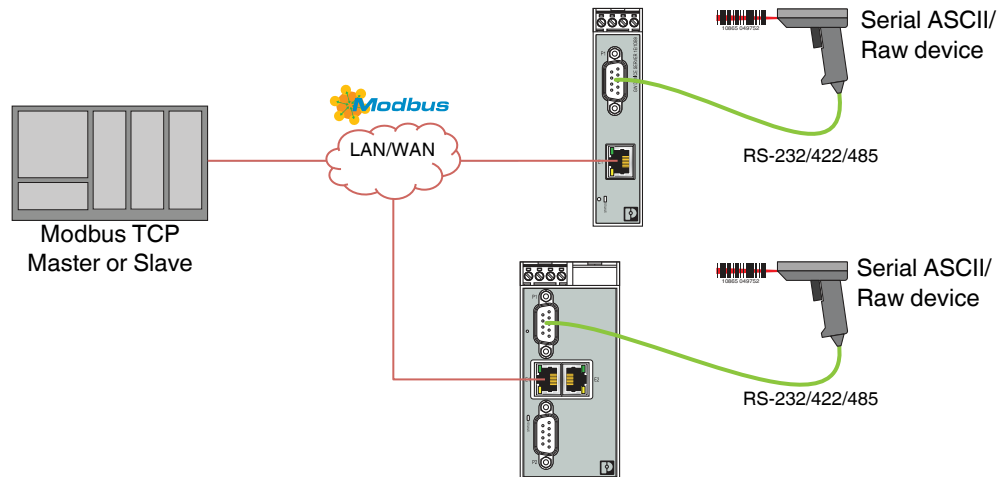

Figure 6 Barcode scanner to Modbus connections

8.3 GW/ EIP/ASCII...

The ASCII to EtherNet/IP converters enable the integration of ASCII serial or TCP/IP barcode scanners, RFID readers, weigh scales, vision systems and encoders, etc. directly into a EtherNet/IP control system. The ASCII strings are mapped into EtherNet/IP registers.

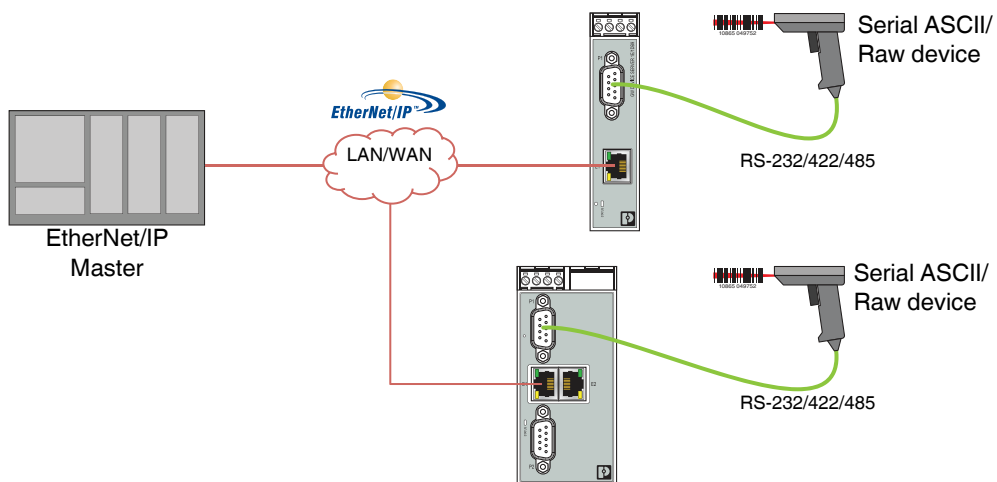

Figure 7 Barcode scanner to EtherNet/IP connections

8.4 GW/ MODBUS/ TCP/RTU...

Modbus RTU to Modbus TCP conversion

The lifetime of legacy serial Modbus RTU/ASCII devices can be easily extended by using the GW/ MODBUS/ TCP/RTU... devices to convert to Modbus TCP. A serial Modbus slave can be connected to a Modbus TCP master, or vice versa.

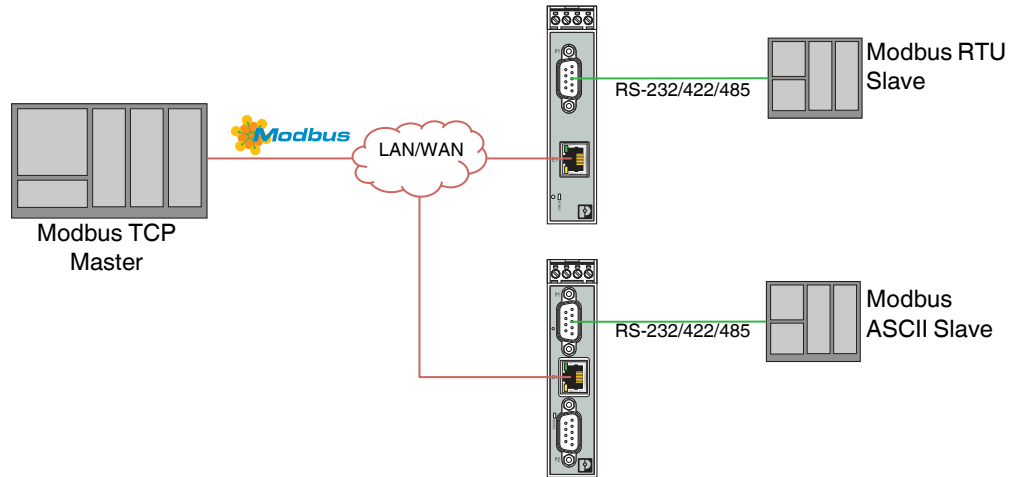

Figure 8 Serial Modbus RTU/ASCII slave to Modbus TCP master

Modbus master to master communication

The “Shared Memory” feature provides a simple and robust method for Modbus master-to-master communication. In this case, the GGW/ MODBUS/ TCP/RTU... emulates a Modbus slave, and each Modbus master can read or write to the “shared” memory in order to exchange data. Any Modbus master (Modbus TCP, serial Modbus RTU/ASCII, and Modbus RTU/ASCII over Ethernet TCP/IP) can access the shared memory.

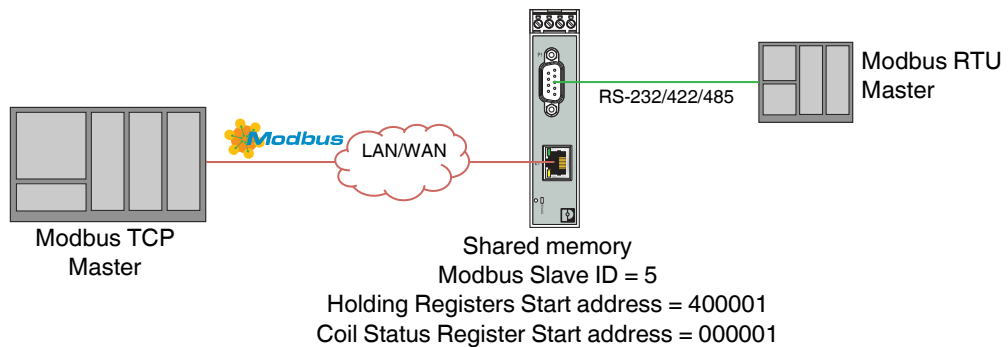

Figure 9 Modbus Master to Master communication using shared memory

Modbus device ID offset

When multiple serial Modbus devices with fixed Device IDs are connected to multiple serial ports on the GW MODBUS TCP/RTU... it is possible to address them separately using the Device ID offset functionality.

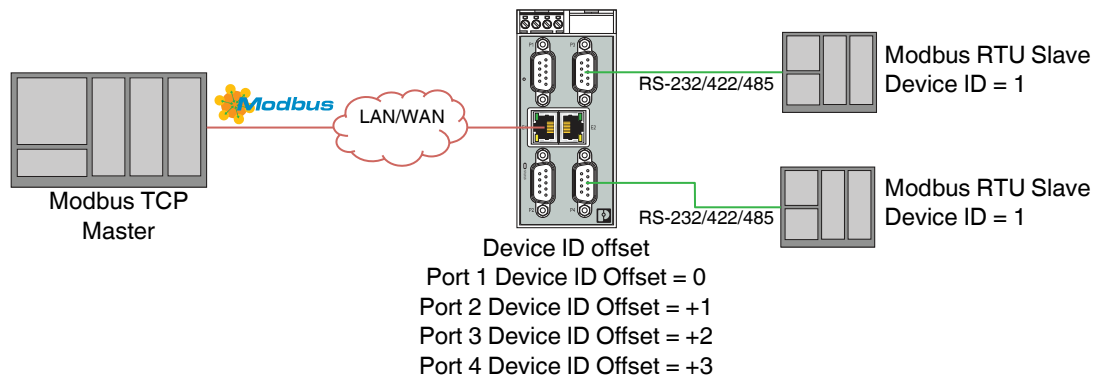

Figure 10 Serial Modbus devices with the same Device ID on a multiport GW/ MODBUS/ TCP/RTU...