

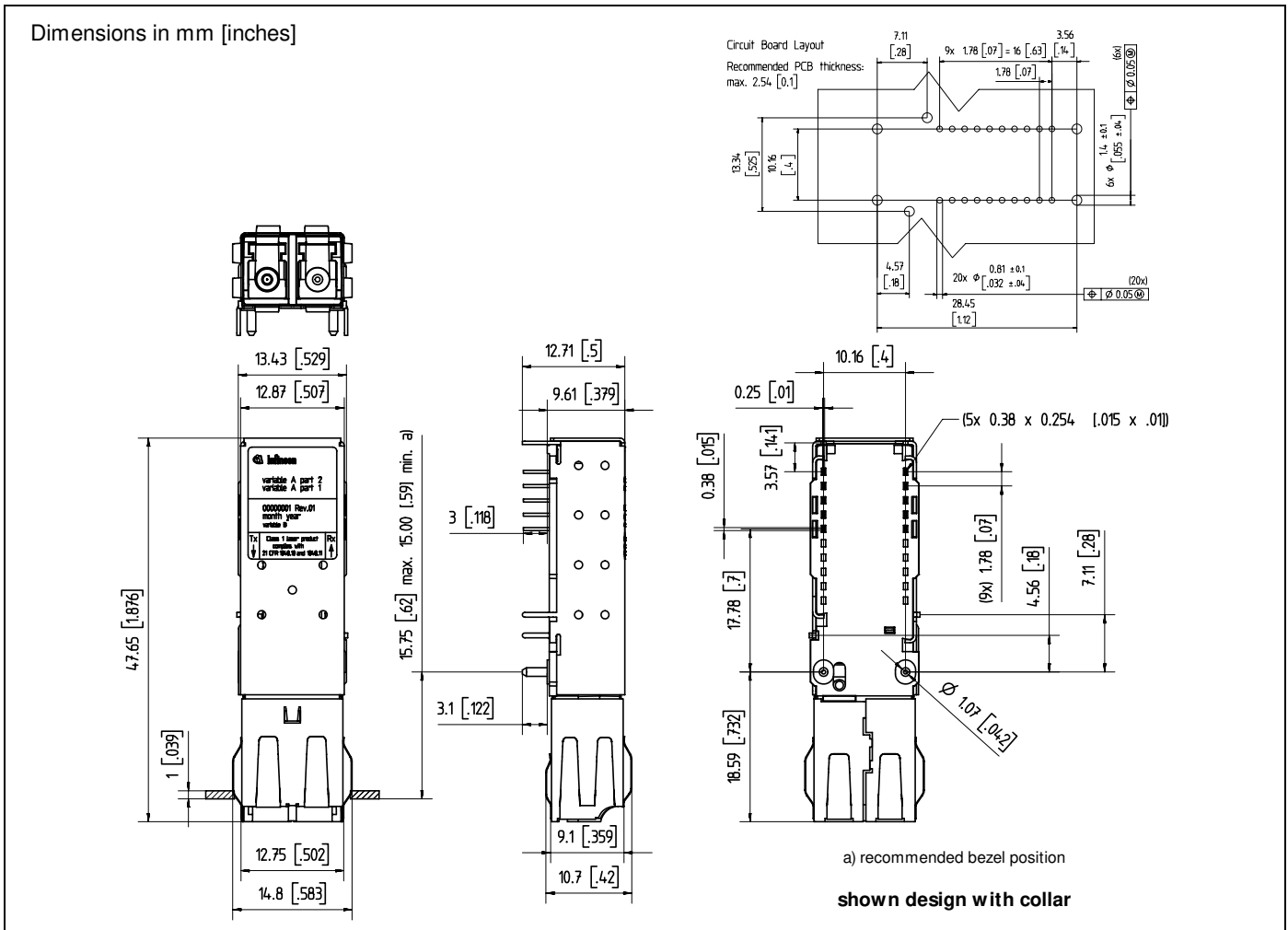

V23818-K305-L17/L57(*)

**Small Form Factor
Multimode 850 nm 1.0625 Gb/s Fibre Channel
1.25 Gigabit Ethernet 2x5 Transceiver
with LC™ Connector**



FEATURES

- Small Form Factor transceiver
- Full compliant with Fibre Channel Standard
- Excellent EMI performance
- RJ-45 style LC™ connector system
- Half the size of SC Duplex 1x9 transceiver
- Single power supply (3.3 V)

- Extremely low power consumption of 445 mW typical
- PECL and LVPECL differential inputs and outputs
- System optimized for 62.5/50 μ m graded index fiber
- Multisource 2x5 footprint
- Small size for high port density
- UL-94 V-0 certified
- ESD Class 1 per MIL-STD 883D Method 3015.7
- Compliant with FCC (Class B) and EN 55022
- For distances of up to 700 m
- Class 1 FDA and IEC laser safety compliant
- AC/AC coupling in accordance to SFF MSA

*) Ordering Information

Input	Output	Signal detect	Voltage	Part Number
DC	DC	TTL	3.3 V	V23818-K305-L17
AC	AC			V23818-K305-L57

LC™ is a trademark of Lucent

Absolute Maximum Ratings

Exceeding any one of these values may destroy the device immediately.

Package Power Dissipation.....	0.5 W
Data Input Levels (PECL).....	$V_{CC}+0.5$ V
Differential Data Input Voltage.....	2.5 V
Storage Ambient Temperature.....	-40°C to 85°C
Soldering Conditions, Temp/Time (MIL-STD 883C, Method 2003).....	250°C/ 5.5 s
V_{CC} max.....	5.5 V
ECL-Output current data.....	50 mA

DESCRIPTION

The Infineon Gigabit Ethernet multimode transceiver – part of Infineon Small Form Factor transceiver family – is based on the Physical Medium Depend (PMD) sublayer and baseband medium, type 1000BASE-SX (short wavelength), Fibre Channel FC-PI 100-M5-SN-I, 100-M6-SN-I FC-PH2 100-M5-SN-I, FC-PH2 100-M6-SN-I.

The appropriate fiber optic cable is 62.5 µm or 50 µm multimode fiber with LC™ connector.

Operating range for over each optical fiber type

Fiber type	Min. (meters)	Typ. (meters)	Max. (meters)
62.5 micron MMF	0.5	2 to 300	400
50.0 micron MMF	0.5	2 to 550	700

The Infineon Gigabit Ethernet multimode transceiver is a single unit comprised of a transmitter, a receiver, and an LC™ receptacle. This design frees the customer from many alignment and PC board layout concerns.

This transceiver supports the LC™ connectorization concept. It is compatible with RJ-45 style backpanels for high end Data Com and Telecom applications while providing the advantages of fiber optic technology.

The module is designed for low cost SAN, LAN, WAN, Fibre Channel and Gigabit Ethernet applications. It can be used as the network end device interface in mainframes, workstations, servers, and storage devices, and in a broad range of network devices such as bridges, routers, hubs, and local and wide area switches.

This transceiver operates at 1 and 1.25 Gbit/s from a single power supply (+3.3 V). The full differential data inputs and outputs are PECL and LVPECL compatible.

Functional Description of 2x5 Pin Row Transceiver

This transceiver is designed to transmit serial data via multimode cable.

Functional Diagram

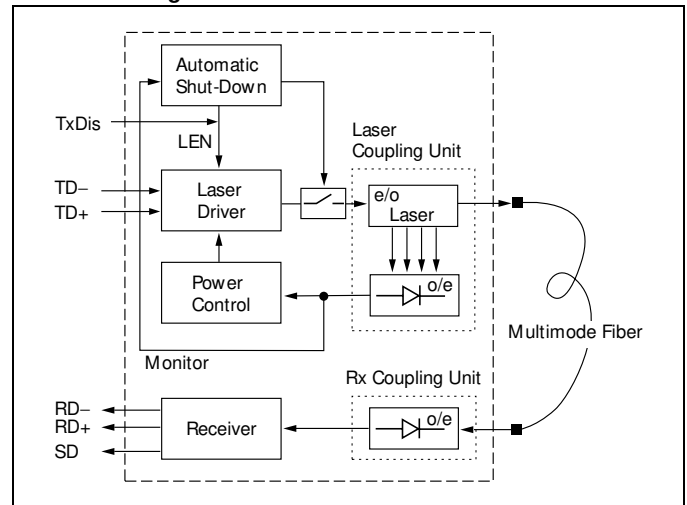

The receiver component converts the optical serial data into PECL compatible electrical data (RD+ and RD-). The Signal Detect (SD, active high) shows whether an optical signal is present.

The transmitter converts PECL compatible electrical serial data (TD+ and TD-) into optical serial data. Data lines are differentially 100 Ω terminated.

The transmitter contains a laser driver circuit that drives the modulation and bias current of the laser diode. The currents are controlled by a power control circuit to guarantee constant output power of the laser over temperature and aging.

The power control uses the output of the monitor PIN diode (mechanically built into the laser coupling unit) as a controlling signal, to prevent the laser power from exceeding the operating limits.

Single fault condition is ensured by means of an integrated automatic shutdown circuit that disables the laser when it detects laser fault to guarantee the laser Eye Safety.

The transceiver contains a supervisory circuit to control the power supply. This circuit makes an internal reset signal whenever the supply voltage drops below the reset threshold. It keeps the reset signal active for at least 140 milliseconds after the voltage has risen above the reset threshold. During this time the laser is inactive.

A low signal on TxDis enables transmitter. If TxDis is high the transmitter is disabled.

TECHNICAL DATA

The electro-optical characteristics described in the following tables are valid only for use under the recommended operating conditions.

Recommended Operating Conditions

Parameter	Symbol	Min.	Typ.	Max.	Units
Ambient Temperature	T _{AMB}	0		70	°C
Power Supply Voltage	V _{CC} - V _{EE}	3.1	3.3	3.5	V
Transmitter					
Data Input High Voltage DC/DC	V _{IH} -V _{CC}	-1165		-880	mV
Data Input Low Voltage DC/DC	V _{IL} -V _{CC}	-1810		-1475	
Data Input Differential Voltage AC/AC	V _{DIFF}	250		2400	
Receiver					
Input Center Wavelength	λ _C	770		860	nm

Transmitter Electro-Optical Characteristics

Transmitter	Symbol	Min.	Typ.	Max.	Units
Launched Power (Average) ⁽¹⁾	P _O	-9.5	-6	-4	dBm
Optical Modulation Amplitude ⁽³⁾	OMA	156	450		μW
Center Wavelength	λ _C	830	850	860	nm
Spectral Width (RMS)	σ _I			0.85	
Relative Intensity Noise	RIN			-116	dB/Hz
Extinction Ratio (Dynamic)	ER	9	13		dB
Total Tx Jitter	TJ		53	130	ps
Reset Threshold ⁽²⁾	V _{TH}	2.2	2.7	2.99	V
Reset Time Out ⁽²⁾	t _{RES}	140	240	560	ms
Rise Time, 20%–80%	t _R			260	ps
Power Supply Current			65	75	mA

Notes

1. Into multimode fiber, 62.5 μm or 50 μm diameter.
2. Laser power is shut down if power supply is below V_{TH} and switched on if power supply is above V_{TH} after t_{RES}.
3. Fibre Channel PI Standard.

Receiver Electro-Optical Characteristics

Receiver	Symbol	Min.	Typ.	Max.	Units
Sensitivity (Average Power) ⁽¹⁾	P _{IN}		-20	-17	dBm
Saturation (Average Power)	P _{SAT}	0			
Min. Optical Modulation Amplitude ⁽⁶⁾	OMA		19	31	μW
Stressed Receiver Sensitivity 50 μm Fiber	S _{PIN}		24	55	μW ⁽⁷⁾
			-17	-13.5	dBm ⁽⁸⁾
Stressed Receiver Sensitivity 62.5 μm Fiber	S _{PIN}		32	67	μW ⁽⁷⁾
			-16	-12.5	dBm ⁽⁸⁾
Signal Detect Assert Level ⁽²⁾	P _{SDA}		-24	-18	dBm
Signal Detect Deassert Level ⁽³⁾	P _{SDD}	-30	-27		
Signal Detect Hysteresis	P _{SDA} - P _{SDD}		3		dB
Signal Detect Assert Time	t _{ASS}			100	μs
Signal Detect Deassert Time	t _{DAS}			350	
Receiver 3 dB cut-off Frequency ⁽⁶⁾			1.25	1.5	GHz
			1.5	3	
Receiver 10 dB cut-off Frequency ⁽⁶⁾					
Data Output Differential Voltage AC/AC ⁽⁴⁾	V _{DIFF}	0.5	0.7	1.23	V
Return Loss of Receiver	A _{RL}	12			dB
Output Data Rise/Fall Time	t _{R-RX} , t _{F-RX}			260	ps
Supply current ⁽⁵⁾	I _{CCR_X}		75	90	mA

Notes

1. Average optical power at which the BER is 1x10⁻¹². Measured with a 2⁷-1 NRZ PRBS and ER=9 dB.
2. An increase in optical power above the specified level will cause the SIGNAL DETECT output to switch from a Low state to a High state.
3. A decrease in optical power below the specified level will cause the SIGNAL DETECT to change from a High state to a Low state.
4. AC/AC for data. Load 50 Ω to GND or 100 Ω differential. For dynamic measurement a tolerance of 50 mV should be added.
5. Supply current excluding Rx output load.
6. Fibre Channel PI Standard.
7. Measured at the given Stressed Receiver Eye Closure Penalty and DCD component given in Fibre Channel PI Standard (2.03/2.18 dB & 40/80 ps).
8. Measured according to IEEE 802.3

Pin Description

Pin Name		Level/Logic	Pin#	Description
V _{EEr}	Receiver Signal Ground	N/A	1	
V _{CCr}	Receiver Power Supply	N/A	2	
SD	Signal Detect	TTL	3	Normal Operation: Logic "1" Output, represents that light is present at receiver input Fault Condition: Logic "0" Output
RD-	Received Data Out Not	PECL	4	
RD+	Received Data Out	PECL	5	
V _{CCt}		N/A	6	Transmitter Power Supply
V _{EEt}		N/A	7	Transmitter Signal Ground
TxDis	Transmitter Disable/Enable	TTL Input	8	A low signal switches the laser on. A high signal switches the laser off.
TD+	Transmit Data	PECL	9	Transmitter Data In
TD-	Transmit Data Not	PECL	10	Transmitter Data In
MS	Mounting Studs	N/A	MS1 MS2	Mounting Studs are provided for transceiver mechanical attachment to the circuit board. They also provide an optional connection of the transceiver to the equipment chassis ground.
HL	Housing Leads	N/A	HL1 HL2 HL3 HL4	The transceiver Housing Leads are provided for additional signal grounding. The holes in the circuit board must be included and be tied to signal ground. (See Application Notes).

Pin Information

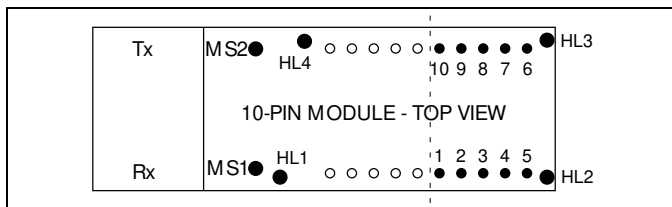

Regulatory Compliance

Feature	Standard	Comments
ESD: Electrostatic Discharge to the Electrical Pins	EIA/JESD22-A114-A (MIL-STD 883D Method 3015.7)	Class 1 (> 1000 V)

Feature	Standard	Comments
Immunity: Against Electrostatic Discharge (ESD) to the Duplex LC Receptacle	EN 61000-4-2 IEC 61000-4-2	Discharges ranging from ± 2 kV to ± 15 kV on the receptacle cause no damage to transceiver (under recommended conditions).
Immunity: Against Radio Frequency Electro-magnetic Field	EN 61000-4-3 IEC 61000-4-3	With a field strength of 3 V/m rms, noise frequency ranges from 10 MHz to 2 GHz. No effect on transceiver performance between the specification limits.
Emission: Electromagnetic Interference (EMI)	FCC 47 CFR Part 15, Class B EN 55022 Class B CISPR 22	Noise frequency range: 30 MHz to 18 GHz

EYE SAFETY

This laser based multimode transceiver is a Class 1 product. It complies with IEC 60825-1 and FDA 21 CFR 1040.10 and 1040.11.

To meet laser safety requirements the transceiver shall be operated within the maximum operating limits.

Caution

All adjustments have been made at the factory prior to shipment of the devices. No maintenance or alteration to the device is required.

Tampering with or modifying the performance of the device will result in voided product warranty.

Note

Failure to adhere to the above restrictions could result in a modification that is considered an act of "manufacturing", and will require, under law, recertification of the modified product with the U.S. Food and Drug Administration (ref. 21 CFR 1040.10 (i)).

Laser Data

Wavelength	850 nm
Total output power (as defined by IEC: 7 mm aperture at 1.4 cm distance)	<675 μ W
Total output power (as defined by FDA: 7 mm aperture at 20 cm distance)	<70 μ W
Beam divergence	12°

Required Labels

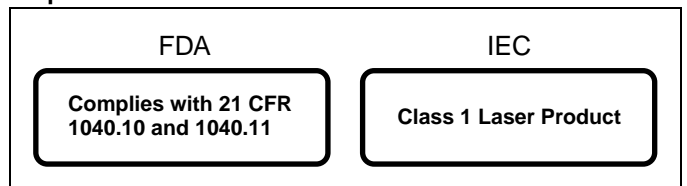

Laser Emission

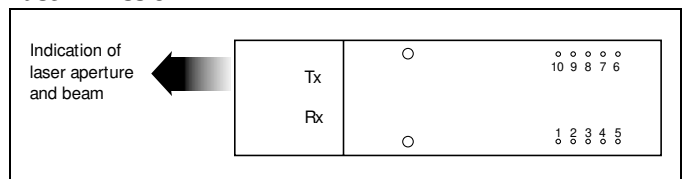

APPLICATION NOTES

Small Form Factor Pinning Comparison

The drawing below gives you a comparison between the different pinning 2x5, 2x6, 2x10. Dimension for diameter and distance of additional pins is similar to the existing dimensions of the other pins.

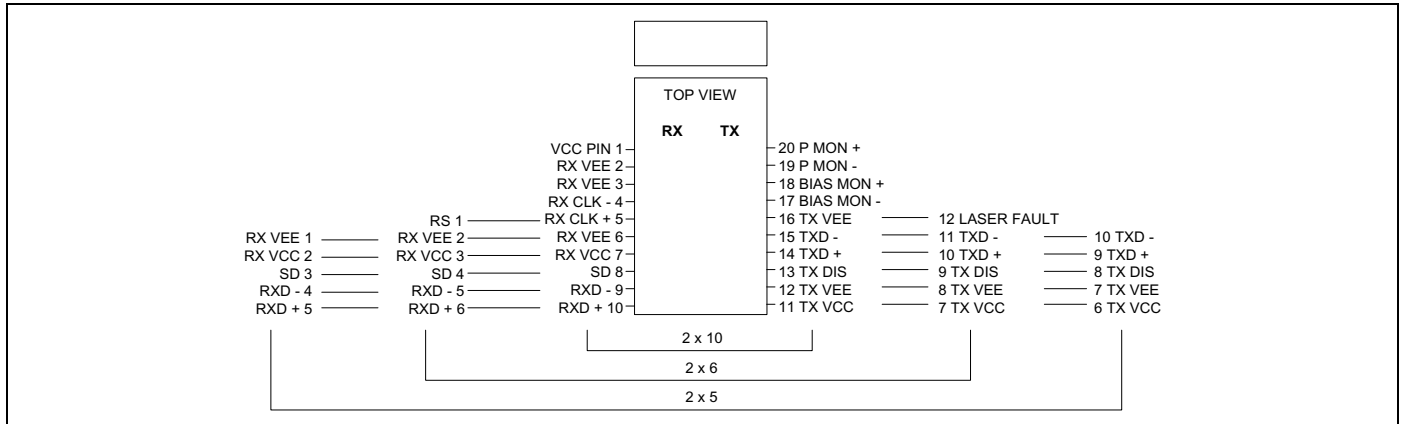

Pin Description

RS pin

The RS Rate Select: is not connected.

LF pin

The LF pin (Laser Fault) is a TTL output of the Laser Driver Supervisor Circuit. A Logic "1" level can be measured in case of a laser fault. It will not show a fault if the laser is being disabled using the TxDis input, since this is not a fault condition.

EMI-Recommendation

To avoid electromagnetic radiation exceeding the required limits please take note of the following recommendations.

When Gigabit switching components are found on a PCB (multiplexers, clock recoveries etc.) any opening of the chassis may produce radiation also at chassis slots other than that of the device itself. Thus every mechanical opening or aperture should be as small as possible.

On the board itself every data connection should be an impedance matched line (e.g. strip line, coplanar strip line). Data, Datanot should be routed symmetrically, vias should be avoided. A terminating resistor of 100 Ω should be placed at the end of each matched line. An alternative termination can be provided with a 50 Ω resistor at each (D, Dn). In DC coupled systems a thevenin equivalent 50 Ω resistance can be achieved as follows: For 3.3 V: 125 Ω to V_{CC} and 82 Ω to V_{EE} , for 5 V: 82 Ω to V_{CC} and 125 Ω to V_{EE} at Data and Datanot. Please consider whether there is an internal termination inside an IC or a transceiver.

In certain cases signal GND is the most harmful source of radiation. Connecting chassis GND and signal GND at the plate/bezel/ chassis rear e.g. by means of a fiber optic transceiver may result in a large amount of radiation. Even a capacitive coupling between signal GND and chassis may be harmful if it is too close to an opening or an aperture.

If a separation of signal GND and chassis GND is not possible, it is strongly recommended to provide a proper contact between signal GND and chassis GND at every location where possible. This concept is designed to avoid hotspots. Hotspots are places of highest radiation which could be generated if only a few connections between signal and chassis GND exist. Compensation currents would concentrate at these connections, causing radiation.

By use of Gigabit switching components in a design, the return path of the RF current must also be considered. Thus a split GND plane of Tx and Rx portion may result in severe EMI problems.

A recommendation is to connect the housing leads to signal GND. However, in certain applications it may improve EMI performance by connecting them to chassis GND.

The cutout should be sized so that all contact springs make good contact with the face plate.

Please consider that the PCB may behave like a waveguide. With an ϵ_r of 4, the wavelength of the harmonics inside the PCB will be half of that in free space. In this scenario even the smallest PCBs may have unexpected resonances.

Transceiver Pitch

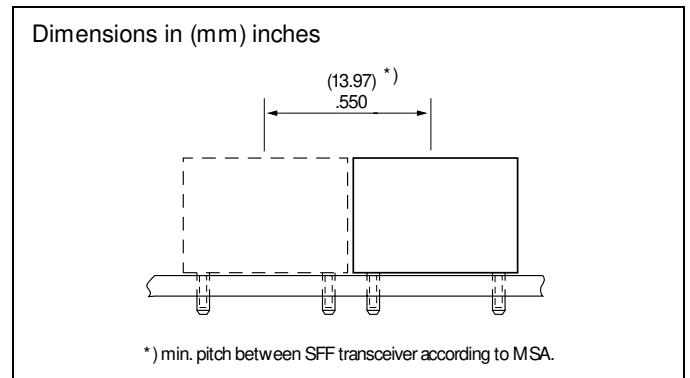

Multimode 850 nm Gigabit Ethernet/Fibre Channel 2x5 Transceiver, AC/AC

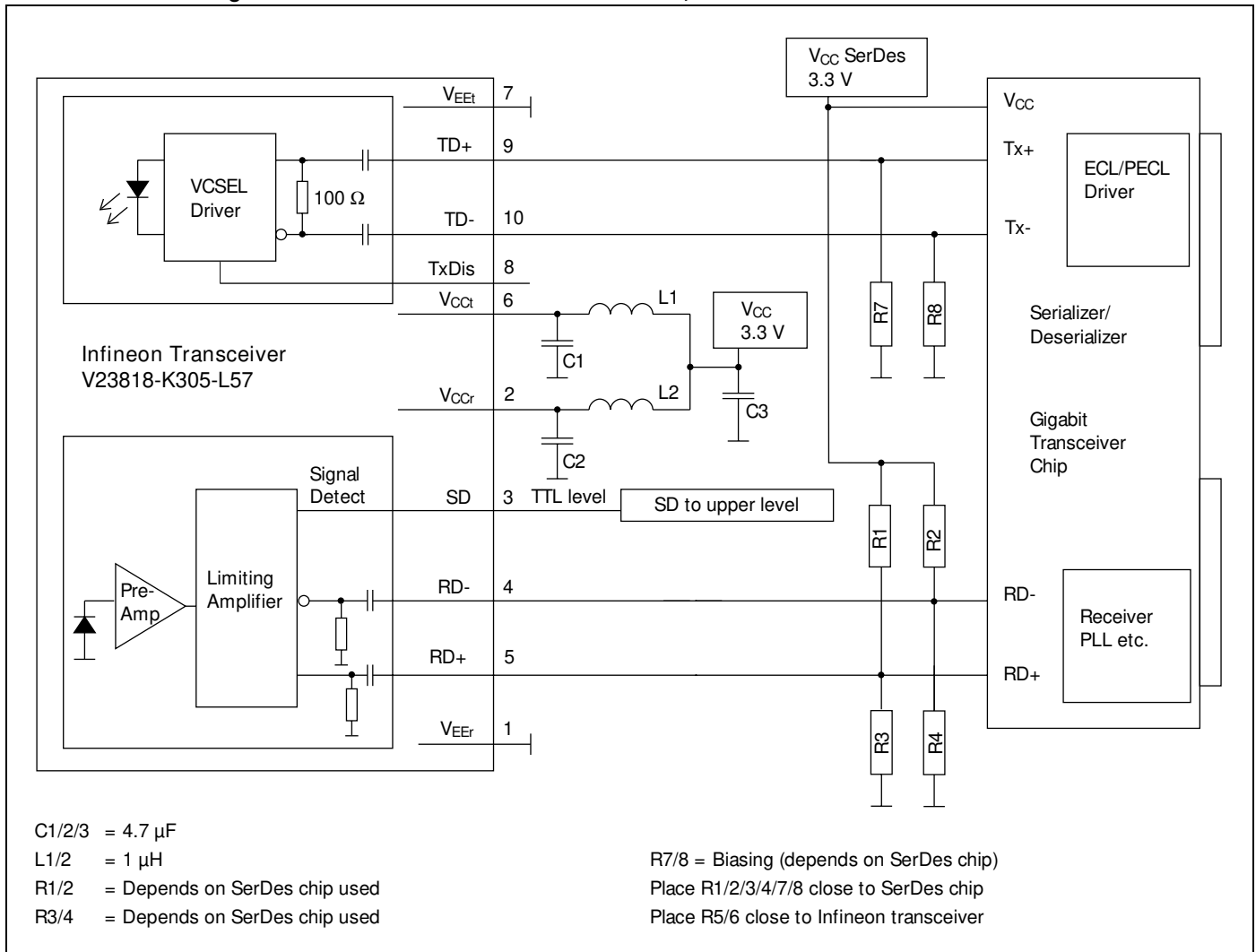

Values of R1/2/3/4 may vary as long as proper 50 Ω termination to V_{EEr} or 100 Ω differential is provided. The power supply filter-

ing is required for good EMI performance. Use short tracks from the inductor L1/L2 to the module V_{CCRx}/V_{CCTx} .

Multimode 850 nm Gigabit Ethernet 2x5 Transceiver DC/DC Version

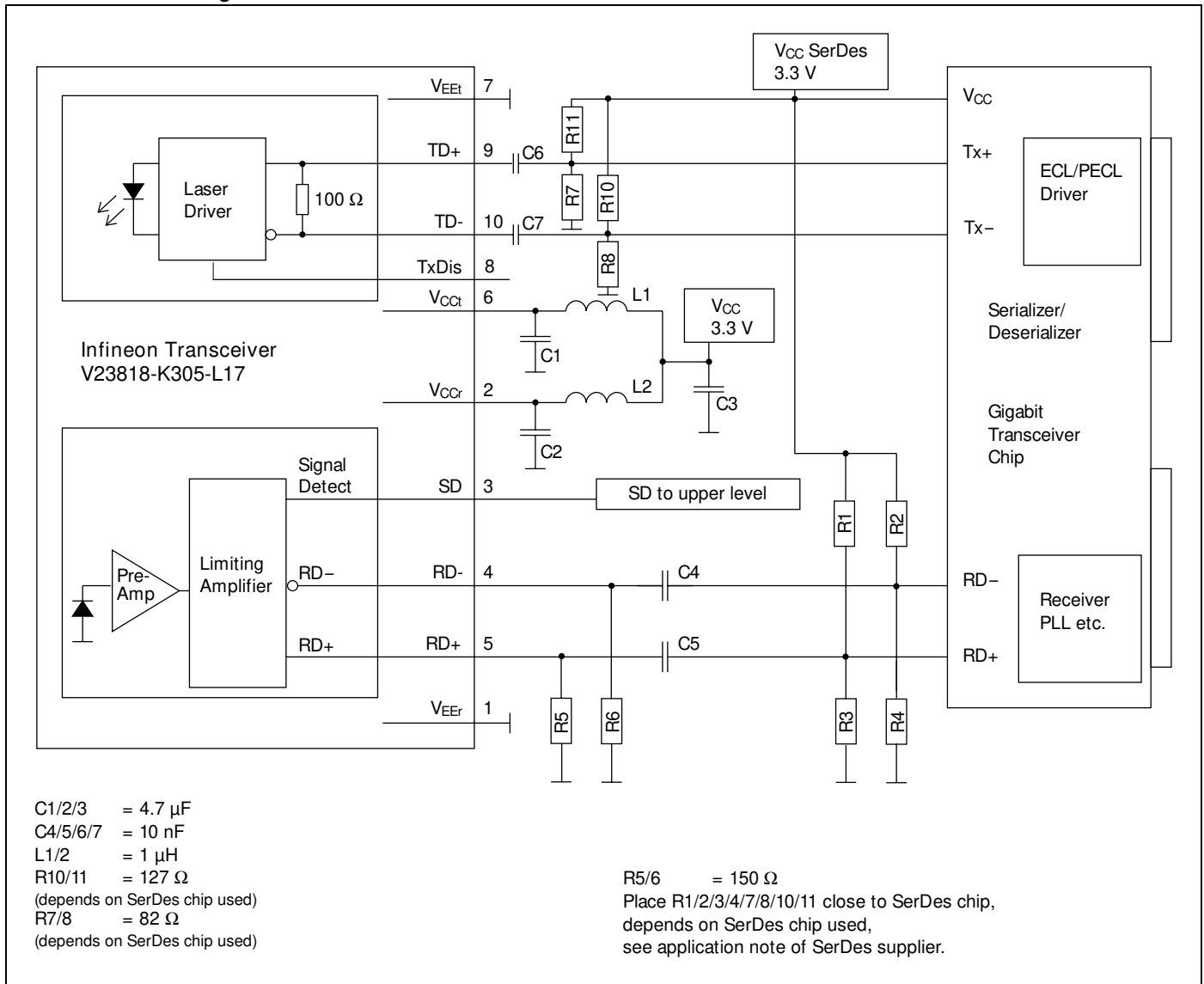

Published by Infineon Technologies AG

© Infineon Technologies AG 2002
All Rights Reserved

Attention please!

The information herein is given to describe certain components and shall not be considered as warranted characteristics.
Terms of delivery and rights to technical change reserved.
We hereby disclaim any and all warranties, including but not limited to warranties of non-infringement, regarding circuits, descriptions and charts stated herein.
Infineon Technologies is an approved CECC manufacturer.

Information

For further information on technology, delivery terms and conditions and prices please contact the Infineon Technologies offices or our Infineon Technologies Representatives worldwide - see our webpage at www.infineon.com/fiberoptics

Warnings

Due to technical requirements components may contain dangerous substances. For information on the types in question please contact your Infineon Technologies offices.
Infineon Technologies Components may only be used in life-support devices or systems with the express written approval of Infineon Technologies, if a failure of such components can reasonably be expected to cause the failure of that life-support device or system, or to affect the safety or effectiveness of that device or system. Life support devices or systems are intended to be implanted in the human body, or to support and/or maintain and sustain and/or protect human life. If they fail, it is reasonable to assume that the health of the user or other persons may be endangered.