



**austriamicrosystems AG**

**is now**

**ams AG**

The technical content of this austriamicrosystems datasheet is still valid.

**Contact information:**

**Headquarters:**

ams AG

Tobelbaderstrasse 30

8141 Unterpremstaetten, Austria

Tel: +43 (0) 3136 500 0

e-Mail: [ams\\_sales@ams.com](mailto:ams_sales@ams.com)

Please visit our website at [www.ams.com](http://www.ams.com)

# AS1337

## 200mA, DC-DC Step-Up Converter with Buck Mode

### 1 General Description

The AS1337 is a synchronous, fixed frequency, high efficiency DC-DC boost converter capable of supplying 3.3V @ 200mA from two AA Cells. Compact size and minimum external parts requirements make these devices perfect for modern portable devices. The AS1337 offers automatic powersave mode to increase efficiency at light loads. For input voltages higher than VOUT the AS1337 will switch in a step down mode, so that a Buck Boost function is realized.

The AS1337A offers a shutdown mode where the battery is connected directly to the output enabling the supply of real-time-clocks or memories.

In the shutdown mode of the AS1337B the battery is disconnected and the output is discharged.

Table 1. Standard Products

Model	Operation Mode
AS1337A	Battery Connected in Shutdown
AS1337B	Battery Disconnected in Shutdown and Output Discharged

The AS1337 offers a POK (open-drain) feature which detects output power fail of 10%.

The AS1337 is available in a TDFN (3x3mm) 8-pin package.

### 2 Key Features

- Input Voltage Range: 0.65V to 4.5V
- Low Start-Up Voltage: 0.85V
- Output Voltage Range: 2.5V to 5.0V
- Delivers 200mA @ 3.3V (from two AA Cell)
- up to 97% Efficiency
- High-Speed Fixed-Frequency: 1.2MHz
- Single-Cell Operation
- Internal PMOS Synchronous Rectifier
- Automatic Powersave Operation
- Anti-Ringing Control Minimizes EMI
- Logic Controlled Shutdown (< 1µA)
- TDFN (3x3mm) 8-pin Package

### 3 Applications

The AS1337 is ideal for low-power applications where ultra-small size is critical as in medical diagnostic equipment, hand-held instruments, pagers, digital cameras, remote wireless transmitters, MP3 players, LCD bias supplies, cordless phones, GPS receivers, and PC cards.

Figure 1. AS1337 - Typical Application Diagram – Dual Cell to 3.3V Synchronous Boost Converter

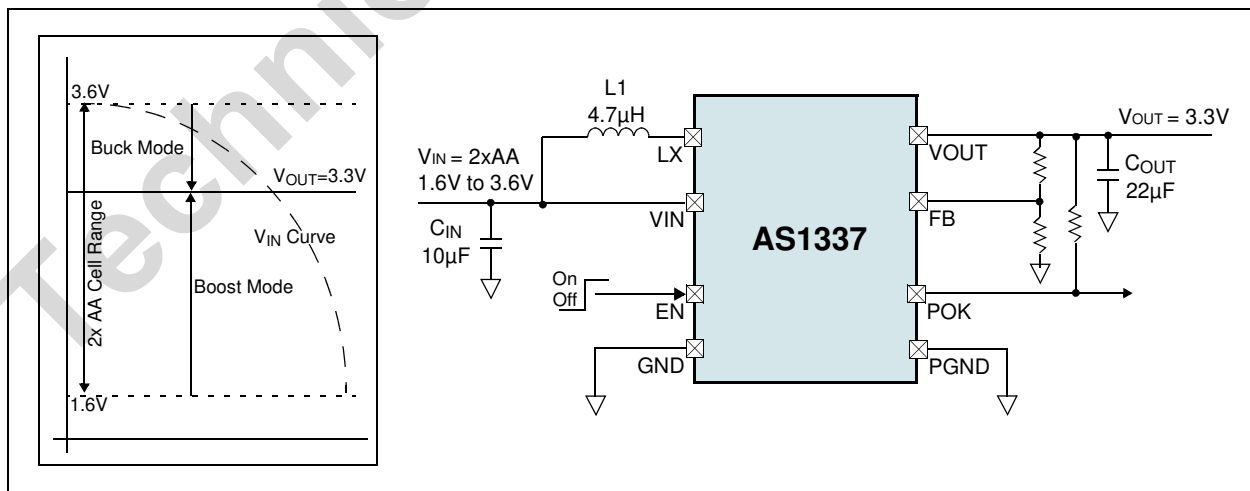

## 4 Pin Assignments

Figure 2. Pin Assignments (Top View)

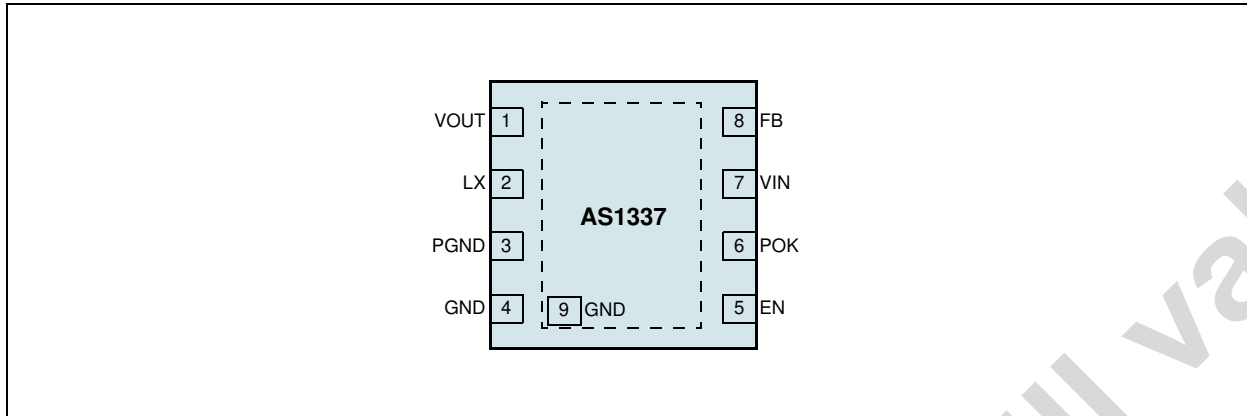

### Pin Descriptions

Table 2. Pin Descriptions

Pin Name	Pin Number	Description
VOUT	1	Output Voltage. Bias is derived from VOUT when VOUT exceeds VIN. PCB trace length from VOUT to the output filter capacitor(s) should be as short and wide as is practical.
LX	2	Switch Pin. Connect an inductor between this pin and VIN. Keep the PCB trace lengths as short and wide as is practical to reduce EMI and voltage overshoot. If the inductor current falls to zero, or pin EN is low, an internal 100Ω anti-ringing switch is connected from this pin to VIN to minimize EMI. <b>Note:</b> An optional Schottky diode can be connected between this pin and VOUT.
PGND	3	Power Ground. Provide a short, direct PCB path between this pin and the output capacitor(s).
GND	4	Ground
EN	5	Enable Pin. Logic controlled enable input. 1 = Normal operation 0 = Shutdown <b>Note:</b> In a typical application, EN should be connected to VIN through a 1MΩ pull-up resistor.
POK	6	POK. High when VOUT is within regulation.
VIN	7	Input Voltage. The AS1337 gets its start-up bias from VIN unless VOUT exceeds VIN, in which case the bias is derived from VOUT. Thus, once started, operation is completely independent from VIN. Operation is only limited by the output power level and the internal series resistance of the supply.
FB	8	Feedback Pin. Feedback input to the gm error amplifier. Connect a resistor divider tap to this pin. The output voltage can be adjusted from 2.5V to 5V by: $V_{OUT} = 1.23V[1 + (R1/R2)]$
GND	9	Exposed Pad Ground

## 5 Absolute Maximum Ratings

Stresses beyond those listed in [Table 3](#) may cause permanent damage to the device. These are stress ratings only, and functional operation of the device at these or any other conditions beyond those indicated in [Section 6 Electrical Characteristics on page 4](#) is not implied. Exposure to absolute maximum rating conditions for extended periods may affect device reliability.

Table 3. Absolute Maximum Ratings

Parameter	Min	Max	Units	Notes
<b>Electrical Parameters</b>				
VIN to GND	-0.3	5.5	V	
FB to GND	-0.3	5	V	
All other pins to GND	-0.3	6	V	
Input Current (latch-up immunity)	-100	100	mA	Norm: JEDEC 78
<b>Electrostatic Discharge</b>				
Human Body Model	2		kV	Norm: MIL 883 E method 3015
<b>Temperature Ranges and Storage Conditions</b>				
Storage Temperature Range	-55	+150	°C	
Package Body Temperature		+260	°C	The reflow peak soldering temperature (body temperature) specified is in accordance with <i>IPC/JEDEC J-STD-020 "Moisture/Reflow Sensitivity Classification for Non-Hermetic Solid State Surface Mount Devices"</i> . The lead finish for Pb-free leaded packages is matte tin (100% Sn).
Humidity non-condensing	5	85	%	
Moisture Sensitive Level	1			Represents a max. floor life time of unlimited

## 6 Electrical Characteristics

$V_{IN} = V_{EN} = +1.2V$ ,  $V_{OUT} = +3.3V$ , Typ values @  $T_{AMB} = +25^{\circ}C$  (unless otherwise specified);

Table 4. Electrical Characteristics

Symbol	Parameter	Conditions	Min	Typ	Max	Units
TAMB	Operating Temperature Range		-45		+85	°C
Input						
	Minimum Start-Up Voltage	ILOAD = 1mA		0.85	1.15	V
	Minimum Operating Voltage	EN = VIN <sup>1</sup>		0.65	0.85	V
VIN	Maximum Input Voltage				4.5	V
	Output Voltage Adjust Range		2.5		5	V
Regulation						
VFB	Feedback Voltage		1.192	1.23	1.268	V
IFB	Feedback Input Current	VFB = 1.25V		1		nA
Operating Current						
IQPWS	Quiescent Current	VFB = 1.4V <sup>2</sup>		20	35	μA
ISHDN	Shutdown Current	EN = GND, VIN = 3.3V		0.01	1	μA
Switches						
INMOSSWL	NMOS Switch Leakage			0.01	1	μA
IPOSSWL	PMOS Switch Leakage	AS1337B only		0.01	1	μA
RONMOS	NMOS Switch On Resistance	VOUT = 3.3V		0.35		Ω
		VOUT = 5V		0.20		
RONPMOS	PMOS Switch On Resistance	VOUT = 3.3V		0.45		Ω
		VOUT = 5V		0.30		
INMOS	NMOS Current Limit			850		mA
	Max Duty Cycle	VFB = 1V	80	87		%
fSW	Switching Frequency		0.95	1.2	1.5	MHz
Shutdown						
VIH	Enable Input Threshold		1			V
VIL					0.3	
IEN	EN Input Current	EN = 5.0V		0.01	1	μA
Power-OK						
	POK Voltage Low	IPOK=1mA		0.1	0.4	V
	POK Leakage Current	VPOK = VIN or VOUT		1	100	nA
	Power-OK Threshold	Falling Edge	86	88	91	%
Thermal Protection						
TENM	Overtemperature Protection			145		°C
ΔTENM	Overtemperature Protection Hysteresis			10		°C

1. Minimum VIN operation after start-up is only limited by the battery's ability to provide the necessary power as it enters a deeply discharged state.
2. IQPWS is measured at VOUT. Multiply this value by VOUT/VIN to get the equivalent input (battery) current.

**Note:** All limits are guaranteed. The parameters with min and max values are guaranteed with production tests or SQC (Statistical Quality Control) methods.

## 7 Typical Operating Characteristics

$V_{OUT} = 3.3V$ ,  $C_{IN} = 10\mu F$ ,  $C_{OUT} = 22\mu F$ ,  $L1 = 4.7\mu H$ ,  $T_{AMB} = +25^\circ C$  (unless otherwise specified).

Figure 3. Efficiency vs.  $I_{OUT}$  - Down Conversion Mode

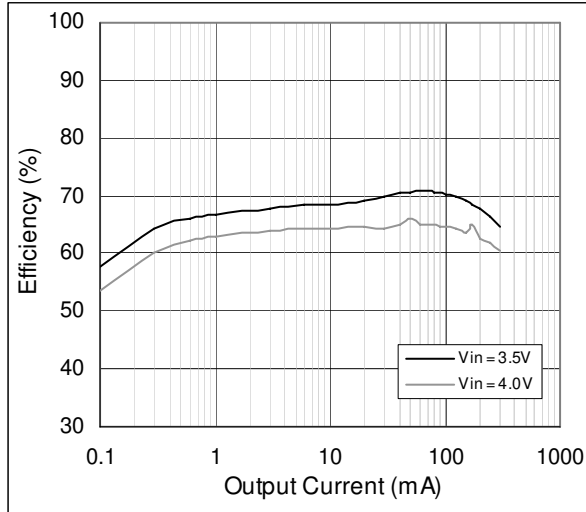

Figure 4. Efficiency vs.  $I_{OUT}$  - Step-up Mode

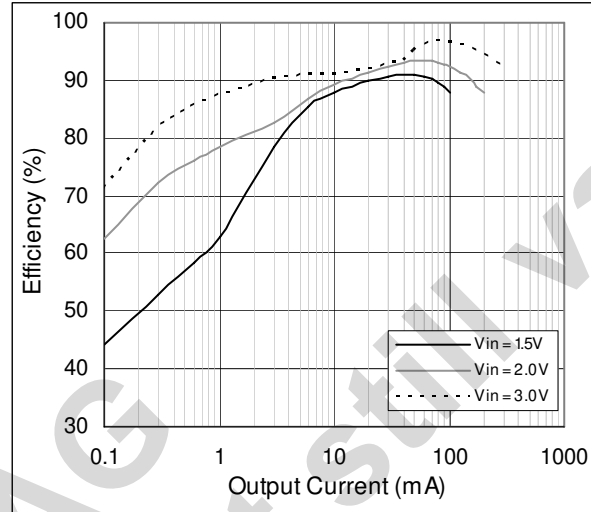

Figure 5. Efficiency vs. Input Voltage

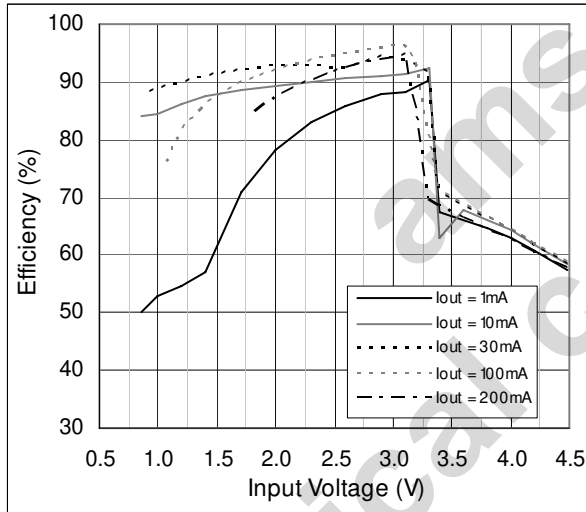

Figure 6. Output Current vs. Input Voltage

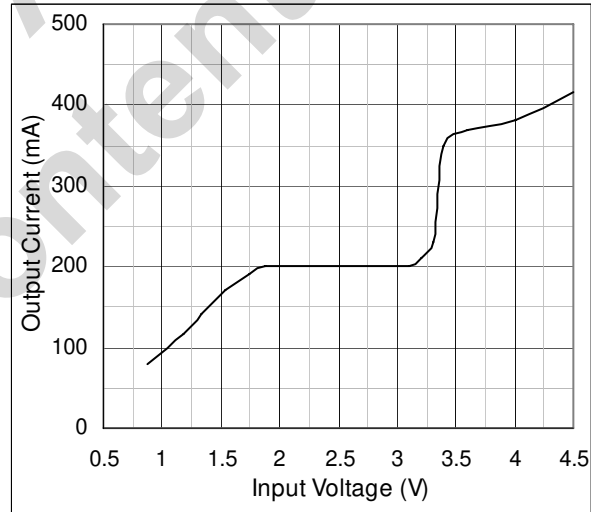

Figure 7. Min. Operating Voltage vs. Temperature

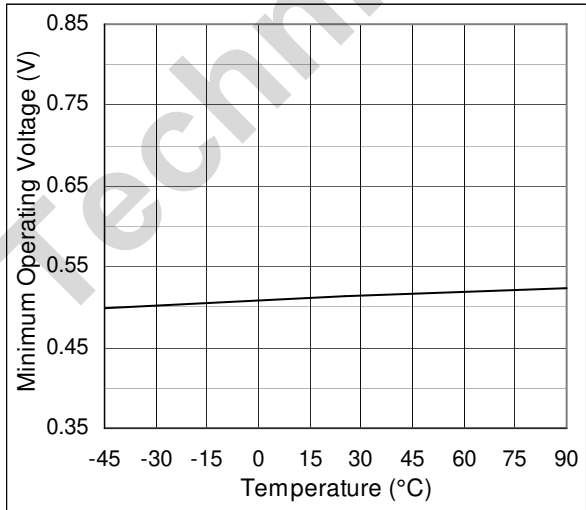

Figure 8. Switching Frequency vs. Temperature

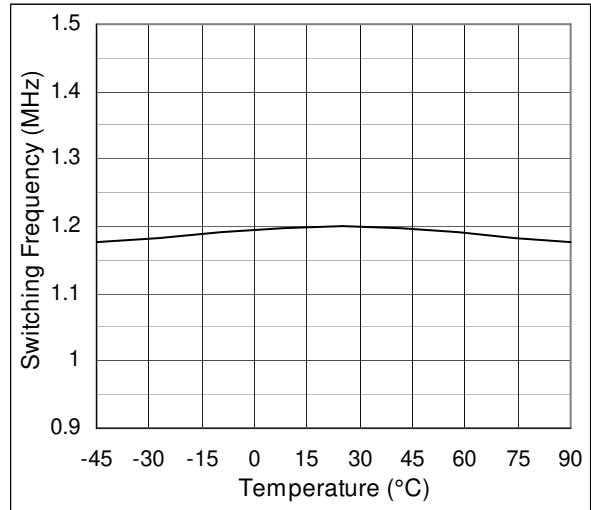

Figure 9. Output Voltage vs. Temp.; ILOAD = 1mA

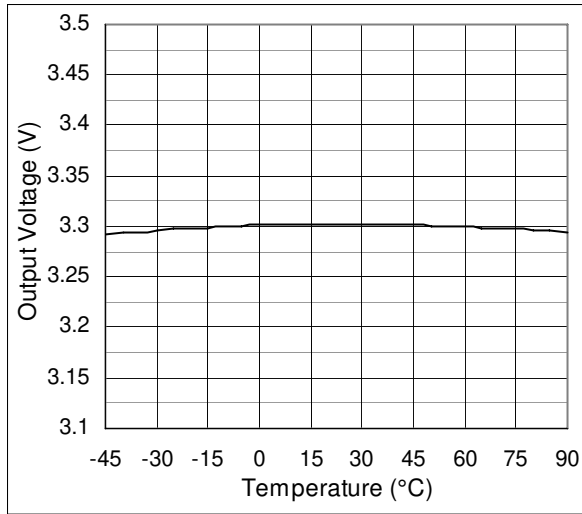

Figure 10. Load Transient Response; VIN = 1.8V

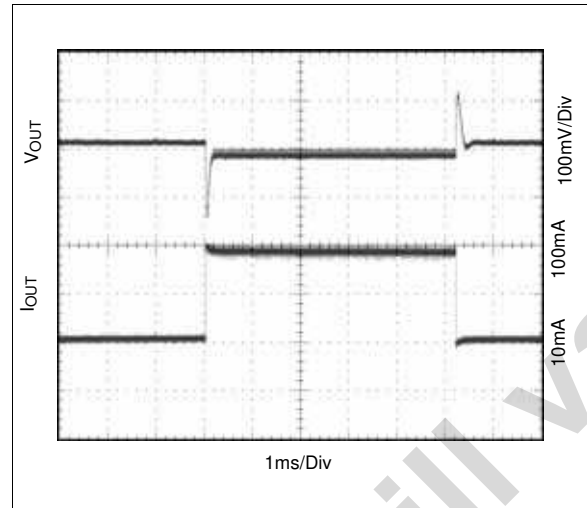

Figure 11. Load Transient Response; VIN = 3.0V

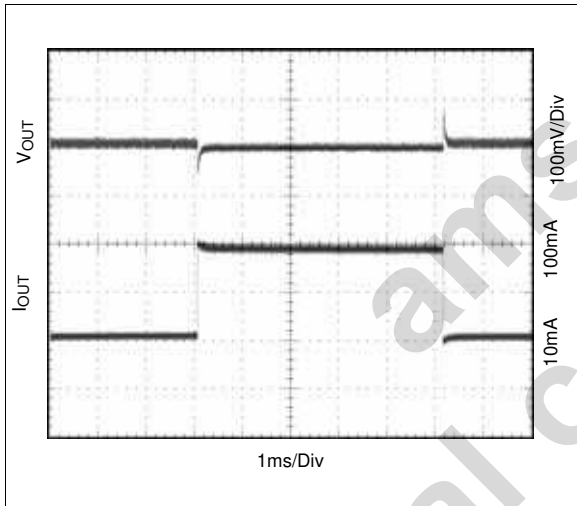
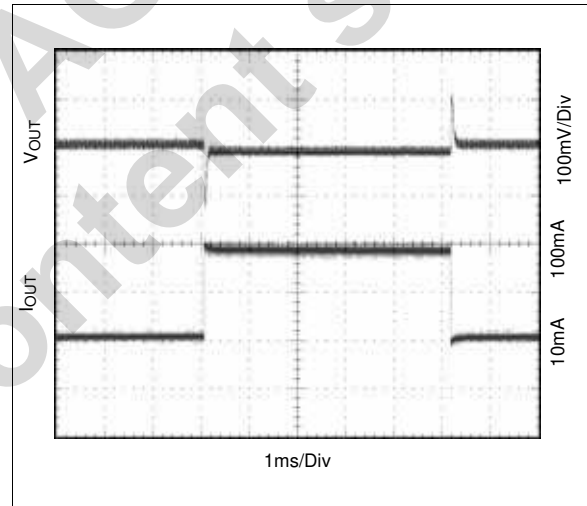

Figure 12. Load Transient Response; VIN = 3.6V



## 8 Detailed Description

The AS1337 can operate from a single-cell input voltage ( $V_{IN}$ ) below 1V, and features fixed frequency (1.2MHz) and current mode PWM control for exceptional line- and load-regulation. With low  $R_{DS(ON)}$  and gate charge internal NMOS and PMOS switches, the device maintains high-efficiency from light to heavy loads.

Modern portable devices frequently spend extended time in low-power or standby modes, switching to high power-drain only when certain functions are enabled. The AS1337 is ideal for portable devices since it maintains high-power conversion efficiency over a wide output power range, thus increasing battery life in these types of applications.

In addition to high-efficiency at moderate and heavy loads, the AS1337 includes an automatic powersave mode that improves efficiency of the power converter at light loads. The powersave mode is initiated if the output load current falls below a factory programmed threshold.

The Overtemperature protection circuitry turn-off both switches for a short time when the temperature reaches 145°C in the device .

Figure 13. AS1337 - Block Diagram

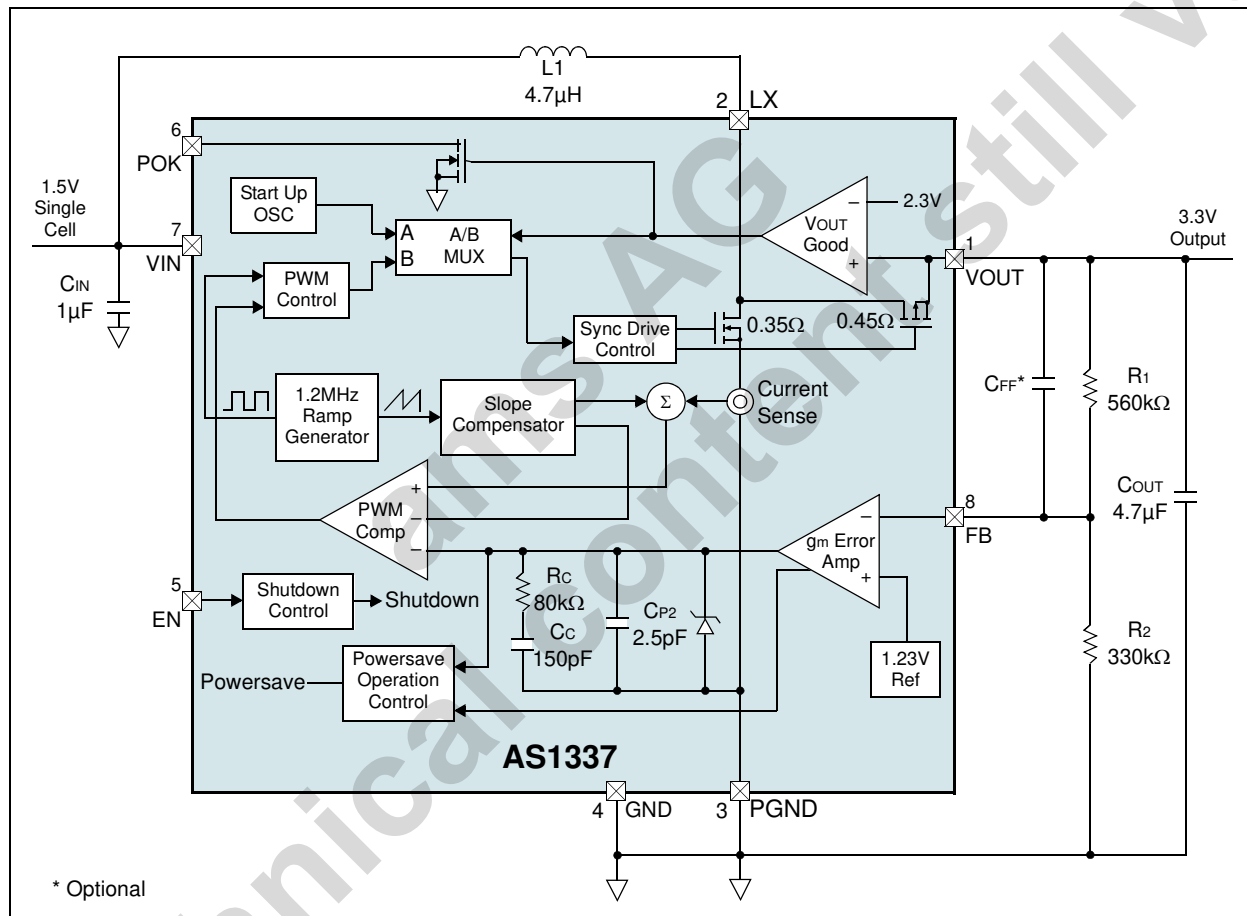



## Low-Voltage Start-Up and Soft Start

The AS1337 requires a  $V_{IN}$  of only 0.85V (typ) or higher to start up. The low-voltage start-up circuitry controls the internal switches and provides a soft start function, where the inductor current during start up is limited for a certain time. This soft start and inrush current limitation feature provides also a smooth curve of  $V_{OUT}$  after start up and makes the overshoot of  $V_{OUT}$  minimal. To achieve this, a 100pF capacitor as CFF is needed (see Figure 13 on page 7) to speed up the feedback loop.

After a certain time a bigger inductor current is allowed and the soft start is disabled.

## Low-Noise Fixed-Frequency Operation

### Oscillator

The AS1337 switching frequency is internally fixed at 1.2MHz allowing the use of very small external components.

### Current Sensing

A signal representing the internal NMOS-switch current is summed with the slope compensator. The summed signal is compared to the error amplifier output to provide a peak current control command for the PWM. Peak switch current is limited to approximately 850mA independent of  $V_{IN}$  or  $V_{OUT}$ .

### Zero Current Comparator

The zero current comparator monitors the inductor current to the output and shuts off the PMOS synchronous rectifier once this current drops to 20mA (approx.). This prevents the inductor current from reversing polarity and results in improved converter efficiency at light loads.

### Anti-Ringing Control

Anti-ringing control circuitry prevents high-frequency ringing on pin LX as the inductor current approaches zero. This is accomplished by damping the resonant circuit formed by the inductor and the capacitance on pin LX.

## Setting Output Voltage

A voltage divider from  $V_{OUT}$  to GND programs the output voltage from 2.5V to 5V via pin FB as:

$$V_{OUT} = 1.23V(1 + (R_1/R_2)) \quad (EQ 1)$$

## Powersave Operation

In light load conditions, the integrated powersave feature removes power from all circuitry not required to monitor  $V_{OUT}$ . When  $V_{OUT}$  has dropped approximately 1% from nominal, the AS1337 powers up and begins normal PWM operation.

$C_{OUT}$  (see Figure 13 on page 7) recharges, causing the AS1337 to re-enter powersave mode as long as the output load remains below the powersave threshold. The frequency of this intermittent PWM is proportional to load current; i.e., as the load current drops further below the powersave threshold, the AS1337 turns on less frequently. When the load current increases above the powersave threshold, the AS1337 will resume continuous, seamless PWM operation.

**Note:** An optional capacitor (CFF) between pins  $V_{OUT}$  and FB in some applications can reduce  $V_{OUT}$ p-p ripple and input quiescent current during powersave mode. Typical values for CFF range from 15pF to 220pF.

## Buck Mode

Both devices, the AS1337A and the AS1337B, offer a low power buck mode for  $V_{IN} > V_{OUT}$  operation. The switching during buck mode is similar to boost mode, but with forced reduction of some energy internal to be able to provide a buck conversion.

## Shutdown

When pin EN is low the AS1337 is switched off and  $<1\mu A$  current is drawn from battery; when pin EN is high the device is switched on. If EN is driven from a logic-level output, the logic high-level (on) should be referenced to  $V_{OUT}$  to avoid intermittently switching the device on.

**Note:** If pin EN is not used, it should be connected directly to pin  $V_{OUT}$ .

**Caution:** Because of the feedthrough the output voltage is the same as the input voltage during shutdown. If  $V_{IN} > V_{OUT}$  the output voltage will jump to the value of the input voltage when the device switches into shutdown. During normal operation the device is in down conversion mode.

### Shutdown Battery Feedthrough (AS1337A)

In shutdown the battery input of the AS1337A is connected to the output through the inductor and the small internal synchronous rectifier P-FET. This allows the input battery to provide backup power for devices such as an idle microcontroller, memory, or real-time-clock, without the usual diode forward drop. In this way a separate backup battery is not needed.

### Shutdown Battery Disconnect (AS1337B)

The AS1337B is designed to allow true output disconnect by opening both P-channel MOSFET rectifiers. During Shutdown VOUT is discharged via the internal NMOS transistor and connected to GND.

### POK Function

The POK output indicates if the output voltage is within 88% (typ.) of the nominal voltage level. As long as the output voltage is within regulation the open-drain POK output is high impedance. The POK output can be tied to VIN or to VOUT or to any external voltage up to VIN or VOUT via a pull-up resistance (see [Figure 1 on page 1](#)). If the output voltage drops below 88% (typ.) of the nominal voltage the POK pin is pulled to GND.

**Note:** It is important to consider that in shutdown mode the POK output is pulled to VIN in order to save current.

## 9 Application Information

The AS1337 is perfectly suited for LED matrix displays, bar-graph displays, instrument-panel meters, dot matrix displays, set-top boxes, white goods, professional audio equipment, medical equipment, industrial controllers to name a few applications.

Along with [Figure 1 on page 1](#), [Figure 14](#) and [Figure 15](#) depict a few of the many applications for which the AS1337 converters are perfectly suited.

Figure 14. Single AA Cell to 3.3V Synchronous Boost Converter

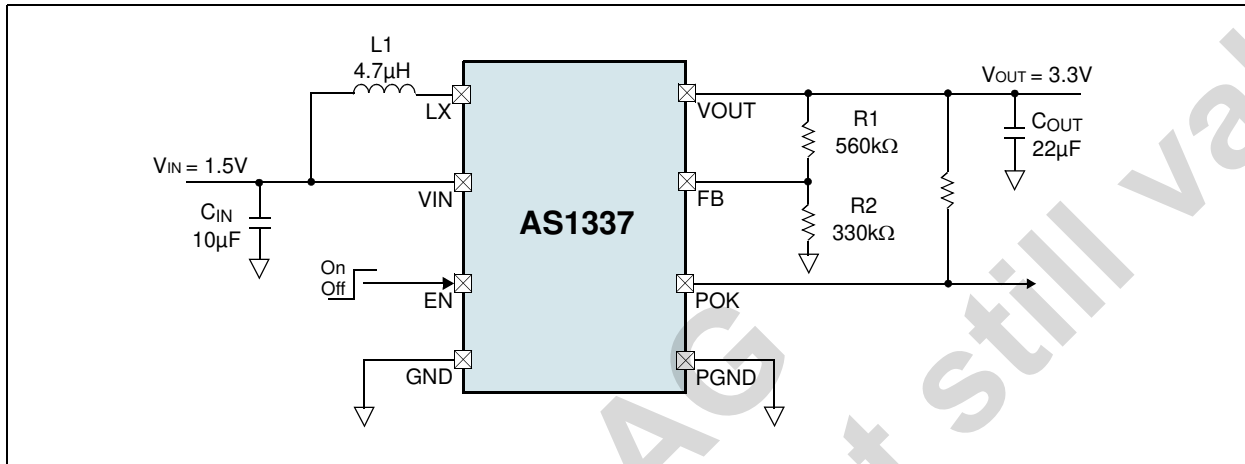
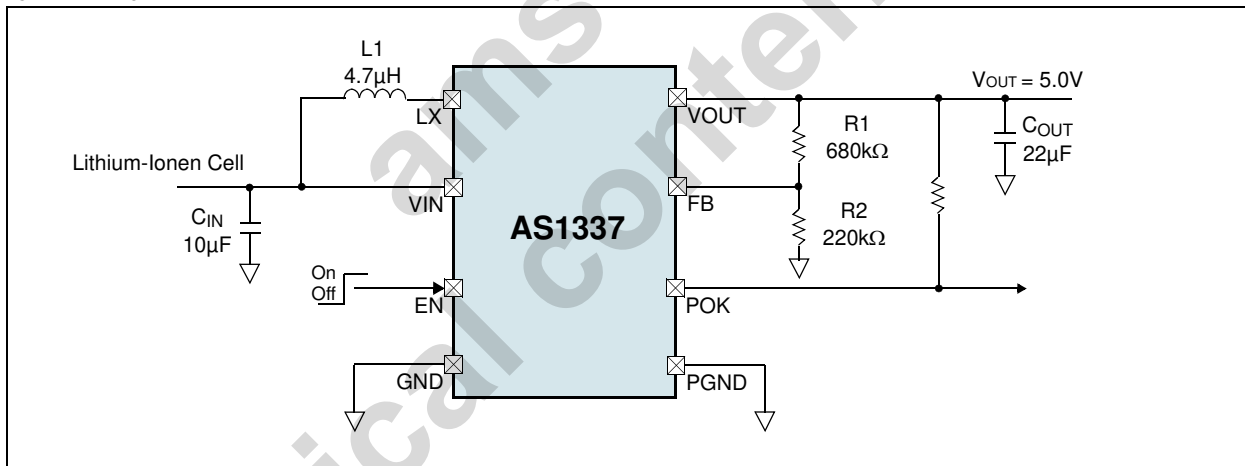

Figure 15. Single Lithium Cell to 5V



## Component Selection

Only three power components are required to complete the design of the buck-boost converter, except the additional two resistors for the voltage divider to set  $V_{OUT}$ . The high operating frequency and low peak currents of the AS1337 allow the use of low value, low profile inductors and tiny external ceramic capacitors.

## Inductor Selection

The inductor should have low ESR to reduce the  $I^2R$  power losses, and must be able to handle the peak inductor current without saturating. High-frequency ferrite core inductor materials reduce frequency dependent power losses compared to less expensive powdered iron types, which result in improved converter efficiency.

A 4.7 $\mu$ H to 15 $\mu$ H inductor value with a >850mA current rating and low DCR is recommended. For applications where radiated noise is a concern, a toroidal or shielded inductor can be used.

## Capacitor Selection

A 10 $\mu$ F capacitor is recommended for  $C_{IN}$  as well as a 22 $\mu$ F for  $C_{OUT}$ . Small-sized ceramic capacitors are recommended. X5R and X7R ceramic capacitors are recommended as they retain capacitance over wide ranges of voltages and temperatures.

## Output Capacitor Selection

Low ESR capacitors should be used to minimize  $V_{OUT}$  ripple. Multi-layer ceramic capacitors are recommended since they have extremely low ESR and are available in small footprints. A 1 to 10 $\mu$ F output capacitor is sufficient for most applications. Larger values up to 22 $\mu$ F may be used to obtain extremely low output voltage ripple and improve transient response.

An additional phase lead capacitor may be required with output capacitors larger than 10 $\mu$ F to maintain acceptable phase margin. X5R and X7R dielectric materials are recommended due to their ability to maintain capacitance over wide voltage and temperature ranges.

## Input Capacitor Selection

Low ESR input capacitors reduce input switching noise and reduce the peak current drawn from the battery. Ceramic capacitors are recommended for input decoupling and should be located as close to the device as is practical. A 4.7 $\mu$ F input capacitor is sufficient for most applications. Larger values may be used without limitations.

Table 5. Recommended External Components

Name	Part Number	Value	Rating	Type	Size	Manufacturer
$C_{IN}$	GRM219R60J106KE19	10 $\mu$ F	6.3V	X5R	0805	Murata <a href="http://www.murata.com">www.murata.com</a>
$C_{OUT}$	GRM21BR60J226ME39	22 $\mu$ F	6.3V	X5R	0805	
L1	MOS6020-472ML	4.7 $\mu$ H	1.82A	50m $\Omega$	6.8x6.0x2.4mm	Coilcraft <a href="http://www.coilcraft.com">www.coilcraft.com</a>

## PCB Layout Guidelines

The high-speed operation of the AS1337 requires proper layout for optimum performance.

- A large ground pin copper area will help to lower the device temperature.
- A multi-layer board with a separate ground plane is recommended.
- Traces carrying large currents should be direct.
- Trace area at pin FB should be as small as is practical.
- The lead-length to the battery should be as short as is practical.

## 10 Package Drawings and Markings

Figure 16. TDFN (3x3mm) 8-pin Marking

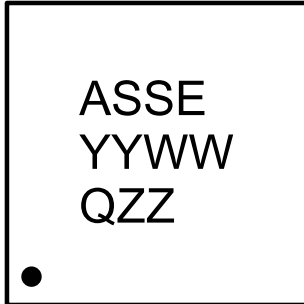
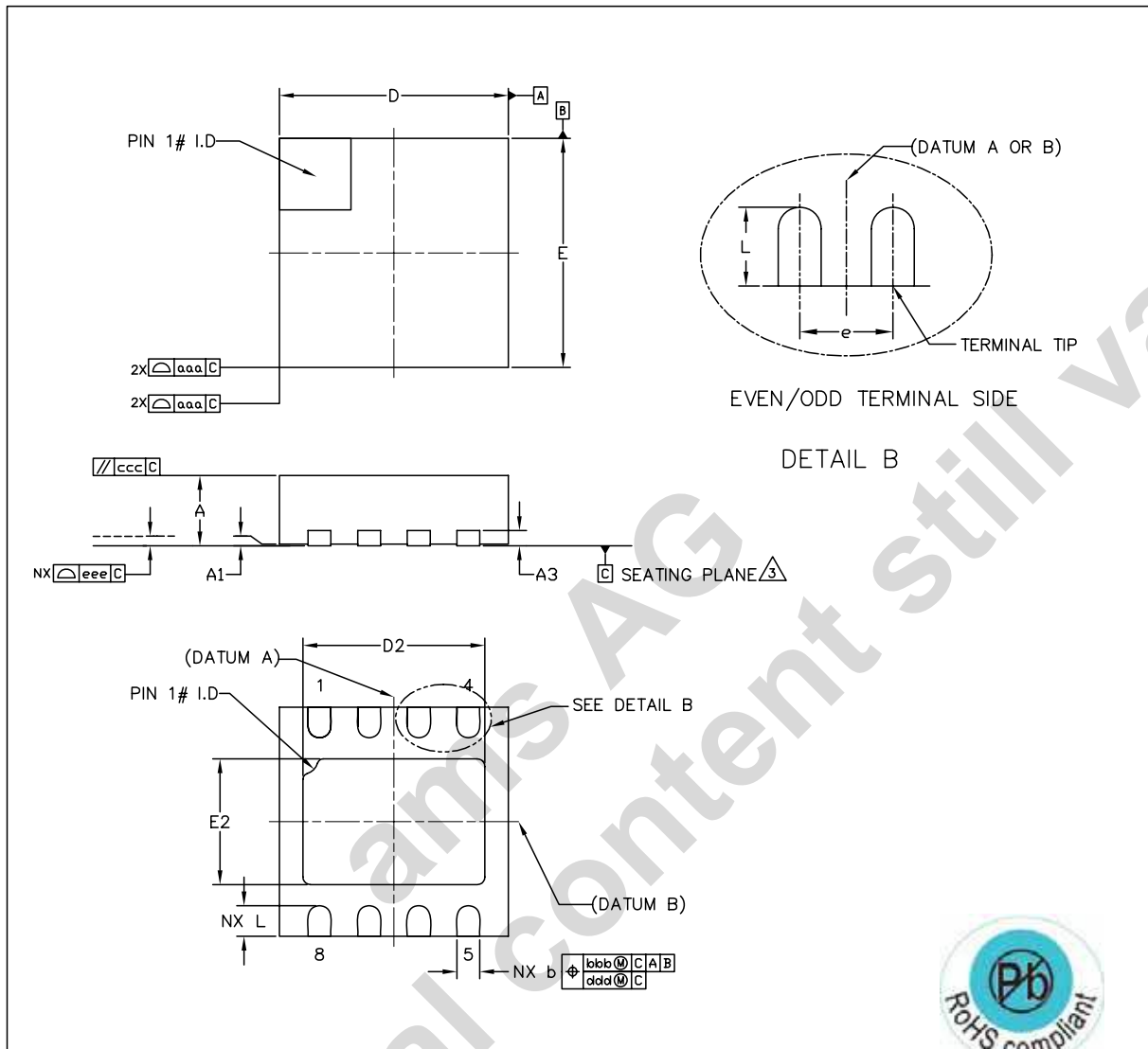

Table 6. Packaging Code YYWWIZZ

YY	WW	Q	ZZ
last two digits of the current year	manufacturing week	plant identifier	free choice / traceability code

Figure 17. TDFN (3x3mm) 8-pin Package



REF.	MIN	NOM	MAX
A	0.70	0.75	0.80
A1	0	0.02	0.05
A3	-	0.20 REF	-
L	0.30	0.40	0.50
b	0.23	0.30	0.38
D	-	3.00 BSC	-
E	-	3.00 BSC	-
D2	2.23	2.38	2.48
E2	1.49	1.64	1.74
e	-	0.65 BSC	-
aaa	-	0.15	-
bbb	-	0.10	-
ccc	-	0.10	-
ddd	-	0.05	-
eee	-	0.08	-
N	-	8	-

NOTE:

- DIMENSIONS & TOLERANCEING CONFIRM TO ASME Y14.5M-1994.
- ALL DIMENSIONS ARE IN MILLIMETERS. ANGELS ARE IN DEGREES.
- COPLANARITY APPLIES TO THE EXPOSED HEAT SLUG AS WELL AS THE TERMINAL.
- RADIUS ON TERMINAL IS OPTIONAL.
- N IS THE TOTAL NUMBER OF TERMINALS.

			ASSEMBLY ENGINEERING		
a leap ahead in analog			TITLE MLPD 3x3x0.75mm, 8 LEAD, 2.38x1.64mm ePAD		
DRAWN RHB		DATE 2010.11.30	REV. N/C	REFERENCE DOCUMENT JEDEC MO-229 LATEST REVISION	
CHECKED GBO		DATE 2010.11.30	DRAWING NO. QBF	UNIT	
APPROVED MKR		DATE 2010.11.30	SHEET 1 OF 1	DIMENSION AND TOLERANCE	SCALE NOT IN SCALE

## 11 Ordering Information

The device is available as the standard products listed in [Table 7](#).

Table 7. Ordering Information

Ordering Code	Marking	Description	Delivery Form	Package
AS1337A-BTDT	ASSE	200mA, DC-DC Step-Up Converter with Buck Mode; Battery Connect in Shutdown	Tape and Reel	TDFN (3x3mm) 8-pin
AS1337B-BTDT	ASSF	200mA, DC-DC Step-Up Converter with Buck Mode; Battery Disconnect in Shutdown and Output Discharged	Tape and Reel	TDFN (3x3mm) 8-pin

**Note:** All products are RoHS compliant and Pb-free.

Buy our products or get free samples online at ICdirect: <http://www.austriamicrosystems.com/ICdirect>

For further information and requests, please contact us <mailto:sales@austriamicrosystems.com>  
or find your local distributor at <http://www.austriamicrosystems.com/distributor>

## Copyrights

Copyright © 1997-2010, austriamicrosystems AG, Tobelbaderstrasse 30, 8141 Unterpremstaetten, Austria-Europe. Trademarks Registered ®. All rights reserved. The material herein may not be reproduced, adapted, merged, translated, stored, or used without the prior written consent of the copyright owner.

All products and companies mentioned are trademarks or registered trademarks of their respective companies.

## Disclaimer

Devices sold by austriamicrosystems AG are covered by the warranty and patent indemnification provisions appearing in its Term of Sale. austriamicrosystems AG makes no warranty, express, statutory, implied, or by description regarding the information set forth herein or regarding the freedom of the described devices from patent infringement. austriamicrosystems AG reserves the right to change specifications and prices at any time and without notice. Therefore, prior to designing this product into a system, it is necessary to check with austriamicrosystems AG for current information. This product is intended for use in normal commercial applications. Applications requiring extended temperature range, unusual environmental requirements, or high reliability applications, such as military, medical life-support or life-sustaining equipment are specifically not recommended without additional processing by austriamicrosystems AG for each application. For shipments of less than 100 parts the manufacturing flow might show deviations from the standard production flow, such as test flow or test location.

The information furnished here by austriamicrosystems AG is believed to be correct and accurate. However, austriamicrosystems AG shall not be liable to recipient or any third party for any damages, including but not limited to personal injury, property damage, loss of profits, loss of use, interruption of business or indirect, special, incidental or consequential damages, of any kind, in connection with or arising out of the furnishing, performance or use of the technical data herein. No obligation or liability to recipient or any third party shall arise or flow out of austriamicrosystems AG rendering of technical or other services.



## Contact Information

### Headquarters

austriamicrosystems AG  
Tobelbaderstrasse 30  
A-8141 Unterpremstaetten, Austria

Tel: +43 (0) 3136 500 0  
Fax: +43 (0) 3136 525 01

For Sales Offices, Distributors and Representatives, please visit:

<http://www.austriamicrosystems.com/contact>