

REVISIONS				
P	LTN	DESCRIPTION	DATE	APVD
V		ECN-23-225276	07AUG2023	DR JHW

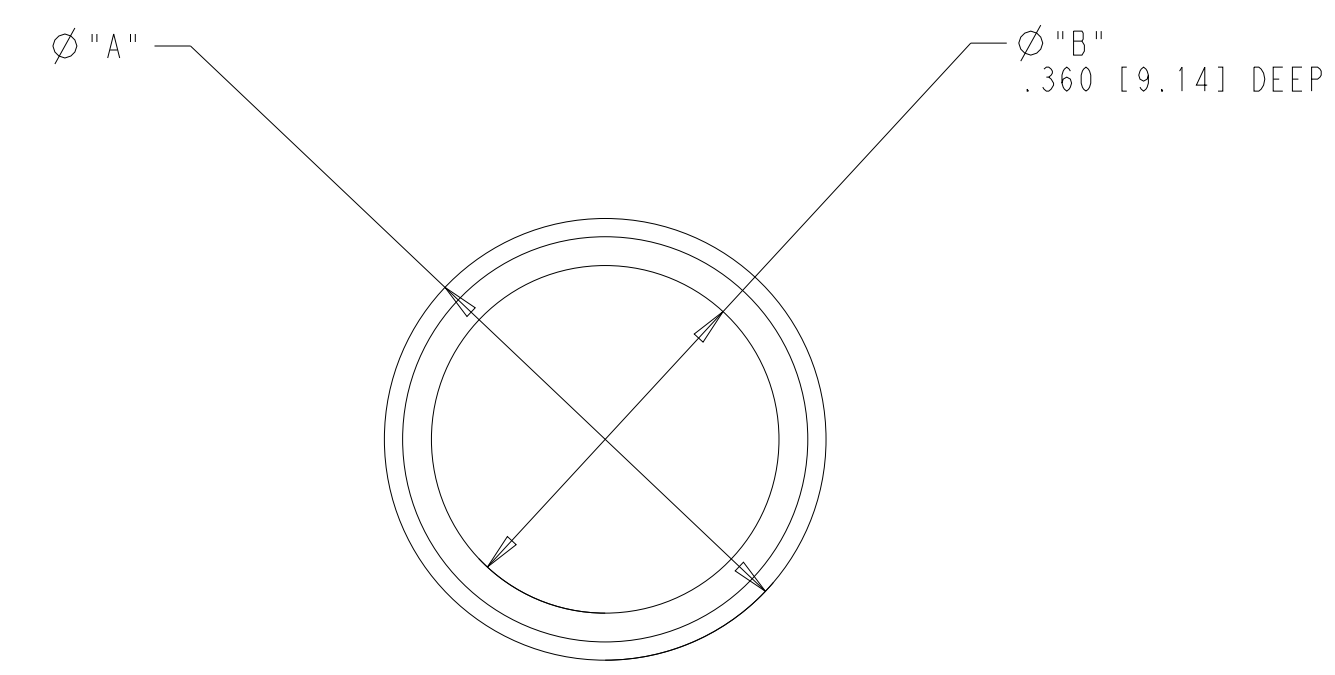

PIN CONTACT BODY  
MAT'L: COPPER ALLOY  
FINISH:  $\triangle 5$

RETENTION CLIP  
MAT'L: PHOS BRONZE  
FINISH: NICKEL PLATED PER QQ-N-290

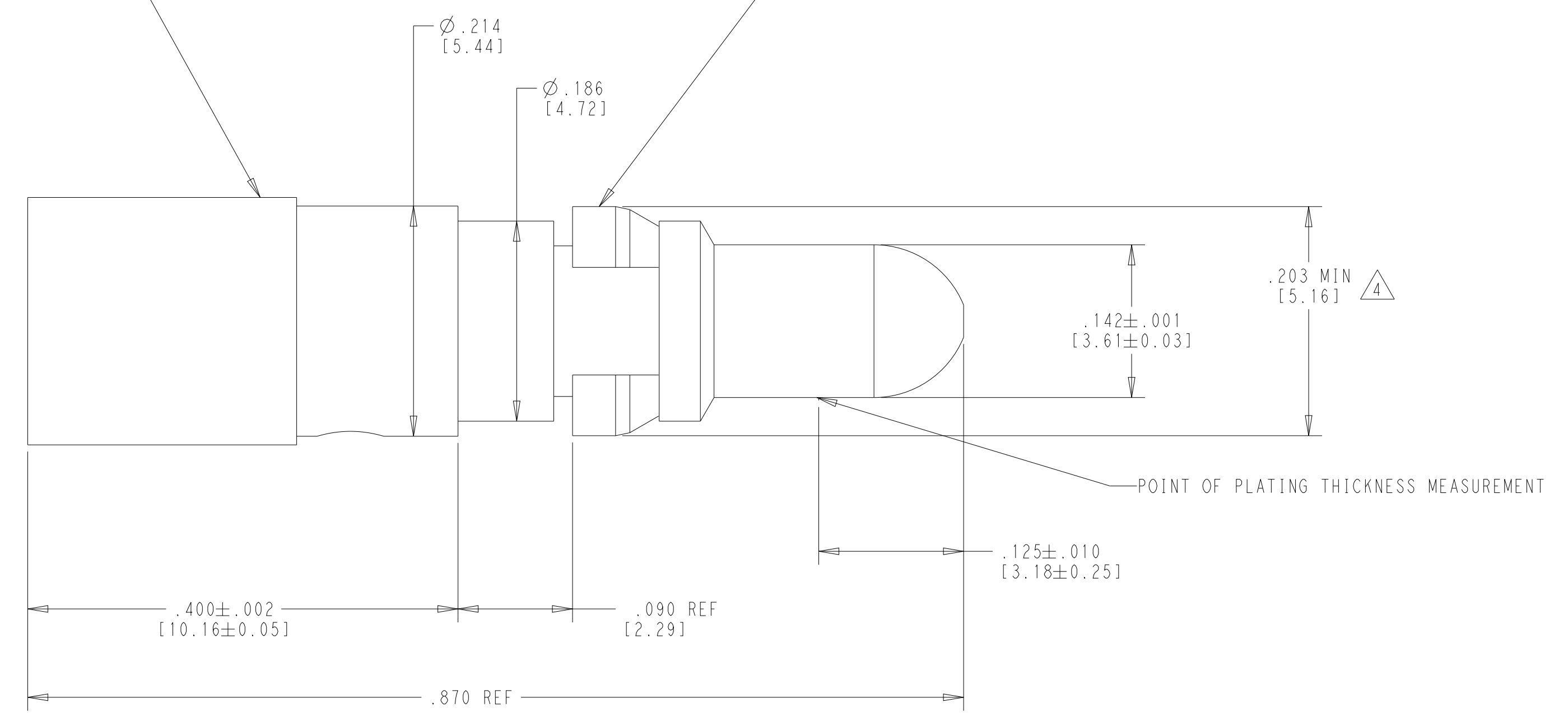

- MATES WITH POWER CONTACT P/N 211161-1 IN AMPLIMITE CONNECTORS ONLY
  - PARTS TO BE USED WITH 8-10AWG STRANDED WIRE ONLY
  - APPROVED CRIMP TOOLING: DANIELS CRIMP TOOLING P/N M300-BT USING DANIELS POSITIONER P/N SP689. STRIP LENGTH .375 IN.  
8AWG SETTING - 7  
10AWG SETTING - 3
- $\triangle 4$  RETENTION CLIP DIAMETER TO BE MEASURED WITH RING GAUGE
- $\triangle 5$  CONTACT FINISH: GOLD PLATED .000050 [.000127] MIN THK PER ASTM-B-488 OVER NICKEL PLATE .000050 [.000127] MIN THK PER QQ-N-290
- $\triangle 6$  RESTRICTED PART NUMBER

$\triangle 6$	.136 [3.45]	.185 [4.70]	10	1-211159-2
$\triangle 6$	.181 [4.60]	.230 [5.84]	8	1-211159-1
--	.136 [3.45]	.185 [4.70]	10	211159-2
--	.181 [4.60]	.230 [5.84]	8	211159-1
REMARKS	DIM 'B'	DIM 'A'	WIRE SIZE [AWG]	PART NUMBER

THIS DRAWING IS A CONTROLLED DOCUMENT.

DWN: C.C. THOMAS 10 NOV 1990  
CHK: D. MILLER 10 NOV 1990  
APVD: D. MILLER 10 NOV 1990

TE Connectivity

NAME: CONTACT ASSEMBLY, PIN, SIZE 8, 8-10AWG

PRODUCT SPEC: 108-10045

APPLICATION SPEC: 114-10014

SIZE: A | CAGE CODE: 00779 | DRAWING NO: 211159

RESTRICTED TO: -

MATERIAL: SEE NOTES  
FINISH: SEE NOTES

CUSTOMER DRAWING

SCALE: 7:1 | SHEET: 1 OF 1 | REV: V