

**DESCRIPTION**

The LX1990 is a dual output current sink optimized for driving light emitting diodes. This low cost bipolar IC enables precise current regulation in LED display lighting applications, yet requires far fewer parts than discrete solutions. The LX1990 is supplied in a micro-miniature 6 lead MLP package featuring a 3 x 3 mm footprint, a profile of less than 1mm, and much improved thermal performance. Its two output sink currents are accurately matched and require only one resistor to program. Program current is only 1% of the output currents, and quiescent current is low, providing a very high efficiency driver for battery-powered displays.

The LX1990 is based on a current-mirror architecture that transfers a reference current produced at the I<sub>SET</sub> pin to each of two open-collector current sinking outputs. The output stages multiply this reference current by 100 to sink independently regulated currents up to 30 mA.

**IMPORTANT:** For the most current data, consult MICROSEMI's website: <http://www.microsemi.com>

Light output from LED's is proportional to average current through them; they can easily produce a brightness range of 500:1. However, color of emitted light is shifted by current amplitude. Color shift at low light levels can be reduced by driving the LED's with a constant peak current while dimming with duty cycle control.

This is achieved by driving the I<sub>SET</sub> resistor with a PWM signal. A 500:1 brightness range can be achieved by choosing 270 Hz as the PWM frequency (to avoid optical beating with 50/60 Hz room lights) and pulse width from 3.7 milliseconds to 7.4 microseconds.

The LX1990 features a shutdown mode via the Enable pin. In this mode the LX1990 consumes less than 1µA and holds the two open collector output stages off. This pin may also be used to pulse width modulate output current. See applications section for dimming details.

**KEY FEATURES**

- Programmable Sink Current 0.1 to 30mA x 2 Channels
- Replaces Discrete Transistor Circuitry With A Single Package
- 300mV Maximum Current Sink Dropout Voltage at 20mA
- 2.7 to 5.5V Power Supply Input
- I<sub>OUT</sub> Compliance Voltage from 0.1 to 10V<sub>DC</sub>
- Enable Input With <1µA Sleep Current
- Amplitude and PWM Dimming
- Current rise and fall time may be controlled to reduce EMI

**APPLICATIONS**

- Cell Phone Display Illumination
- PDA White LED Display Lighting
- Automotive Display Illumination
- Digital Still Camera
- Camcorders
- Consumer Electronics Front Panels

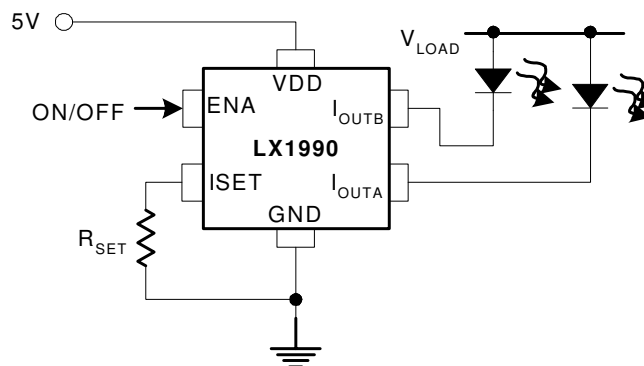
**PRODUCT HIGHLIGHT**

**PACKAGE ORDER INFO**

|                     |           |                      |
|---------------------|-----------|----------------------|
| T <sub>A</sub> (°C) | <b>LM</b> | Plastic MLP<br>6-Pin |
| -40 to 85           |           | LX1990ILM            |

Note: Available in Tape & Reel.  
 Append the letter "T" to the part number. (i.e. LX1990ILM-T)

**ABSOLUTE MAXIMUM RATINGS**

|   |                    |
|---|--------------------|
| Supply Voltage ( $V_{DD}$ ).....          | 6V                 |
| ENA Voltage .....                         | 6V                 |
| $I_{SET}$ Maximum Current .....           | Internally Limited |
| $I_{SET}$ Maximum Voltage.....            | $V_{DD}$           |
| $I_{OUT}$ Maximum Compliance Voltage..... | 12V                |
| Current Source Outputs .....              | 100mA              |
| Operating Temperature Range.....          | -40°C to 85°C      |
| Maximum Junction Temperature.....         | 125°C              |
| Storage Temperature .....                 | -65°C to 150°C     |
| Lead Temperature (Soldering, 10sec).....  | 300°C              |

Note: Exceeding these ratings could cause damage to the device. All voltages are with respect to Ground. Currents are positive into, negative out of specified terminal.

**PACKAGE PIN OUT**

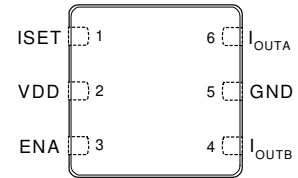

LM PACKAGE  
(Top View)

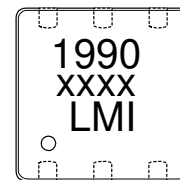

LM PACKAGE MARKINGS  
xxxx – Denotes Date Code / Lot Identification

**THERMAL DATA**

**LM Plastic MLP 6-Pin**

|   |               |
|---|---------------|
| <b>THERMAL RESISTANCE-JUNCTION TO AMBIENT, <math>\theta_{JA}</math></b> | <b>41°C/W</b> |
|---|---------------|

Junction Temperature Calculation:  $T_J = T_A + (P_D \times \theta_{JA})$ .

The  $\theta_{JA}$  numbers are guidelines for the thermal performance of the device/pc-board system. All of the above assume no ambient airflow.

**FUNCTIONAL PIN DESCRIPTION**

| NAME                    | DESCRIPTION   |
|-------------------------|---|
| $V_{DD}$                | Input Supply  |
| GND                     | Common ground reference   |
| ENA                     | Chip Enable Input. If logic high, current source outputs are enabled. If logic low, internal power is disconnected from the $V_{DD}$ pin, disabling all functions. Logic threshold is 1.2 V.  |
| $I_{OUTA}$ & $I_{OUTB}$ | Output Current Source. Two separate constant current outputs. Outputs may be loaded in any combination without affecting regulation of the loaded output. If only one output is needed $I_{OUTA}$ & $I_{OUTB}$ must be shorted together. In this case the value of $I_{SET}$ resistor must be doubled. Compliance voltage range is 0.1V to 10V. |
| $I_{SET}$               | Output current programming pin.   |

**RECOMMENDED OPERATING CONDITIONS**

| Parameter  | LX1990 |     |          | Units   |
|--|--------|-----|----------|---------|
|  | Min    | Typ | Max      |         |
| Supply Voltage ( $V_{DD}$ )                      | 2.7    |     | 5.5      | V       |
| ENA (ENABLE) Input Voltage                       | 0      |     | $V_{DD}$ | V       |
| $I_{SET}$ Voltage                                | 0      |     | 1.25     | V       |
| $I_{SET}$ Current                                | 0      |     | 300      | $\mu A$ |
| $I_{OUTA}$ / $I_{OUTB}$ Compliance Voltage Range | 0.1    |     | 10       | V       |
| $I_{OUTA}$ / $I_{OUTB}$ Output Current Range     | 0.1    |     | 30       | mA      |

**ELECTRICAL CHARACTERISTICS**

Unless otherwise specified, the following specifications apply over the operating ambient temperature  $-40^{\circ}C \leq T_A \leq 85^{\circ}C$  and the following test conditions:  $V_{DD} = 2.7$  to  $5.5$  V<sub>DC</sub>,  $I_{SET} = 200\mu A$ ,  $V_{OUT} \leq 5.5$  V,  $V_{LOAD} \leq 10$  V. Typical values are at  $T_A = 25^{\circ}C$

| Parameter   | Symbol           | Test Conditions   | LX1990 |      |       | Units            |
|---|------------------|---|--------|------|-------|------------------|
|   |                  |   | Min    | Typ  | Max   |                  |
| <b>Power Characteristics</b>                                  |                  |   |        |      |       |                  |
| Quiescent Current   | $I_{QUI}$        | $V_{DD} = 2.7V$ ; $I_{SET} = 0\mu A$                        |        | 1.4  | 2     | mA               |
| Quiescent Current   | $I_{QUI}$        | $V_{DD} = 5.5V$ ; $I_{SET} = 300\mu A$                      |        | 3.0  | 4     | mA               |
| Sleep Current <sup>1</sup>                                    | $I_{SLEEP}$      | $V_{DD} = 5.5V$ , $ENA \leq 0.4V$                           |        | 0.08 | 1     | $\mu A$          |
| <b>Enable Input</b>   |                  |   |        |      |       |                  |
| Enable Logic Threshold  | $V_{TH\_EN}$     |   | 0.8    | 1.55 | 2.4   | V                |
| Enable Input Current  | $I_{IN\_EN}$     | $ENA = V_{DD} = 5.5V$                                       |        | 4    | 10    | $\mu A$          |
| $I_{SET}$ to Out Pulse Response                               | $T_{D(ON)}$      |   |        | 1.2  | 2     | $\mu S$          |
| $I_{SET}$ to Out Pulse Response                               | $T_{D(OFF)}$     |   |        | 1.4  | 2     | $\mu S$          |
| <b>ISET Input</b>   |                  |   |        |      |       |                  |
| $I_{SET}$ Current Range                                       | $I_{SET}$        | $R_{SET}$ terminated to GND                                 | 0      |      | 300   | $\mu A$          |
| $I_{SET}$ Voltage   | $V_{SET}$        | $I_{SET} = 200\mu A$  | 1.225  | 1.25 | 1.275 | V <sub>DC</sub>  |
| <b>Output Characteristics</b>                                 |                  |   |        |      |       |                  |
| Output Current Amplitude                                      | $I_{OUT}$        | $0.5 < V_{OUT} < 5.5V$ , $I_{SET} = 200\mu A$               | 18.5   | 20   | 21.5  | mA <sub>DC</sub> |
| OUTA to OUTB Current Matching                                 | $I_{OUT\_MATCH}$ | $I_{OUT} = 20mA$ ; $(I_{OUTA} - I_{OUTB}) / I_{OUTA} * 100$ |        | 0.4  | 5     | %                |
| $I_{SET}$ to $I_{OUT}$ Current Ratio                          | $I_{OUT\_RATIO}$ | $I_{OUT}/I_{SET}$ ; $I_{SET} = 200\mu A$ ; $V_{DD} = 5.5V$  |        | 102  |       |                  |
| $I_{SET}$ to $I_{OUT}$ Current Ratio                          | $I_{OUT\_RATIO}$ | $I_{OUT}/I_{SET}$ ; $I_{SET} = 200\mu A$ ; $V_{DD} = 2.7V$  |        | 99   |       |                  |
| Output Current $I_{SET} = 0\mu A$                             | $I_{OUT\_ZERO}$  | $0.5 < V_{OUT} < V_{LOAD}$ , $I_{SET} = 0\mu A$             |        | 10   | 100   | $\mu A_{DC}$     |
| Dropout Voltage <sup>2</sup>                                  | $V_{DROPOUT}$    | $I_{OUT} = 20mA$  |        | 150  | 300   | mV               |
| Dropout Voltage <sup>2</sup>                                  | $V_{DROPOUT}$    | $I_{OUT} = 30mA$  |        | 200  | 400   | mV               |
| Maximum Output Current, $I_{SET}$ Shorted To Gnd. Each Output | $I_{SC}$         | $V_{SET} = \text{Zero Volts}$ ; $V_{DD} = 5V$               |        | 100  |       | mA <sub>DC</sub> |
| Output Off State Current                                      | $I_{OUTOFF}$     | $ENA \leq 0.4V$   |        |      | 20    | $\mu A_{DC}$     |

<sup>1</sup> At enable voltages greater than 0.4V but less than 0.8V the outputs will remain off but the sleep current may be greater than 1 $\mu A$ .

<sup>2</sup> Dropout is defined as the OUTA/B to GND voltage at which the output current sink drops 10% from the nominal value.

**SIMPLIFIED BLOCK DIAGRAM**

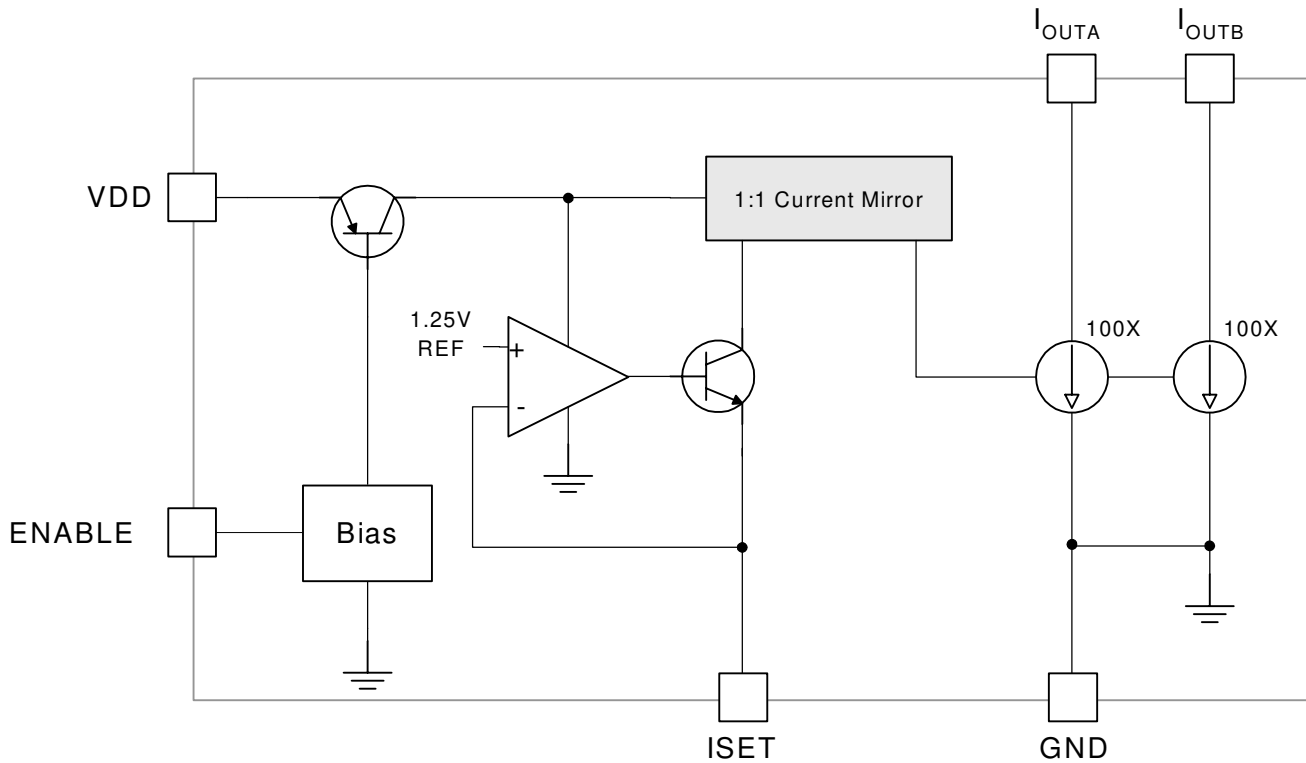

**Figure 1 – Simplified Block Diagram**

**APPLICATIONS**
**FUNCTIONAL DESCRIPTION**

The LX1990 is designed to drive LED's used in display illumination and signaling applications such as cellular telephones and PDA's. With a 5V supply, the two independently regulated constant current outputs can drive 2 white LED's ( $V_F < 4.5V$ ) in parallel, or 4 green or amber LED's ( $V_F < 2.25V$  each) arranged as 2 parallel x 2 in series.

With Dropout voltage of only 300 mV at 20 mA, the LX1990 provides regulated current for 2 green / amber LED's in a cell phone all the way down to the minimum NiCd cutoff of 2.7 volts for three cells.

The LX1990 features resistor settable output current. Connecting a resistor between  $I_{SET}$  and a voltage of zero to 1.25 volts generates a current that is mirrored into each of the output with a gain of about 100. Output current can be varied in an analog fashion by varying  $I_{SET}$  resistance or termination voltage (see application schematics).

Duty cycle dimming with a fixed current amplitude is accomplished by switching the  $I_{SET}$  current on and off with an open collector or open drain pulse width modulated logic signal. Switching frequency can exceed 20 KHz, making it practical to use a PWM output channel from popular micro controllers. The upper limit on frequency is minimum switching response from  $I_{SET}$  to output. As frequency increases, these fixed delays will cause an error in expected output current duty cycle.

All inputs and outputs are ESD and short circuit protected making the LX1990 an exceptionally robust component. However it is not recommended to indefinitely short the  $I_{SET}$  input to ground while shorting the outputs to 10V as the power dissipation under these conditions is the greatest.

**APPLICATION NOTES**

Each output has an independent current sink, however both must be held above about 0.5 volts to maintain specified current regulation accuracy. If only one output is needed, the two outputs should be connected together and the programming resistor value doubled so each output supplies  $\frac{1}{2}$  the desired current. In this case, more than 60 mA total current can be delivered from the combined output.

Package power dissipation can be calculated from the following equation:

$$P_D = (n \cdot I_{OUT}) \cdot (V_{LOAD} - V_{LED})$$

|            |   |                             |
|------------|---|-----------------------------|
| n          | = | Number of outputs used      |
| $I_{OUT}$  | = | Current from each output    |
| $V_{LOAD}$ | = | Output Supply Voltage       |
| $V_{LED}$  | = | Minimum LED forward voltage |
| $P_D$      | = | Power Dissipated in mW      |

When the ENA input is at zero volts, less than  $20\mu A$  current flows into or out of the outputs. If the disable function is used, ENA must be driven below 0.4 volts to insure minimum current from  $V_{DD}$ .

The  $I_{SET}$  pin may be driven with a digital open collector or open drain logic PWM signal to dim the LED's. Recommended PWM frequency for dimming is between 100 Hz and 20 KHz. Below 100 Hz flicker may be observed. Above 20 KHz duty cycle accuracy is reduced due to switching delays from  $I_{SET}$  to outputs. Totem pole output drive may also be used as long as the maximum driver voltage never exceeds the  $V_{DD}$  supply. Since the totem pole drive will exceed the 1.25V  $I_{SET}$  voltage it can introduce delays that may limit the useful frequency and maximum dim range.

If PWM dimming is used, use separate power and ground lines directly from the power source point to prevent noise generated from the LED current transients from entering video or audio subsystems on the same supply rails. Additional power supply filtering may be needed in PWM dimming applications. Care should be exercised in the PCB layout to prevent coupling from the outputs to the  $I_{SET}$  pin, as this may cause the part to oscillate.

Current out of the  $I_{SET}$  pin may be varied for current amplitude dimming. There are two ways to do this: If a mechanical input is needed, a rheostat in series with a resistor connected from GND to  $I_{SET}$  can be used. The second method is to connect a fixed resistor from  $I_{SET}$  to the output of a voltage DAC or other low impedance voltage source. Varying the voltage between zero and 1.25 volts will cause a corresponding output current change from  $I_{OUT}$  max to zero:

$$I_{OUT} = \text{Current Ratio} \times I_{SET}$$

The ENA pin may be used to duty cycle dim the output in applications where only one control line is available for dimming and shutdown. A narrow current spike that may be as high as 100 mA is produced when the ENA signal has very fast rise times. This is not harmful to the LED, but will cause dimming linearity errors when operating at very low duty cycles.

TYPICAL CHARACTERISTICS

VDD = 5V, ENA = 5V, ISET = 200μA, TA = 25°C. Unless otherwise noted.

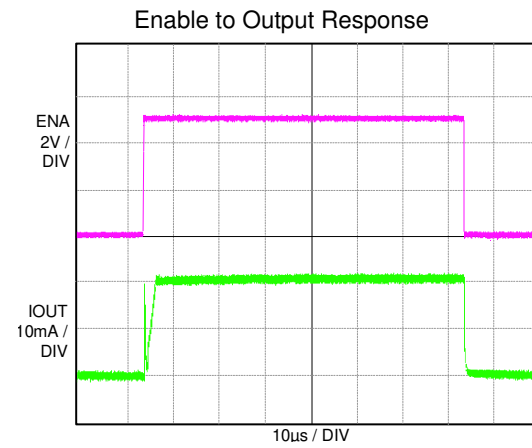
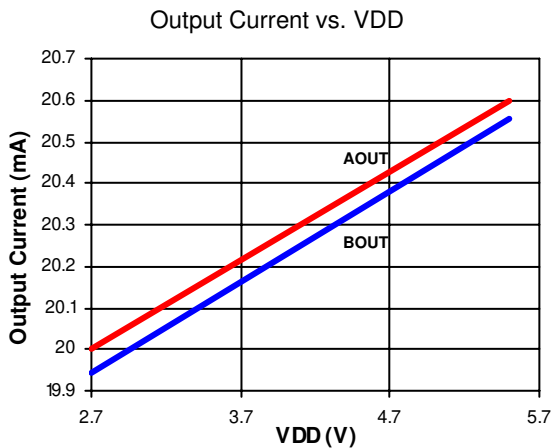
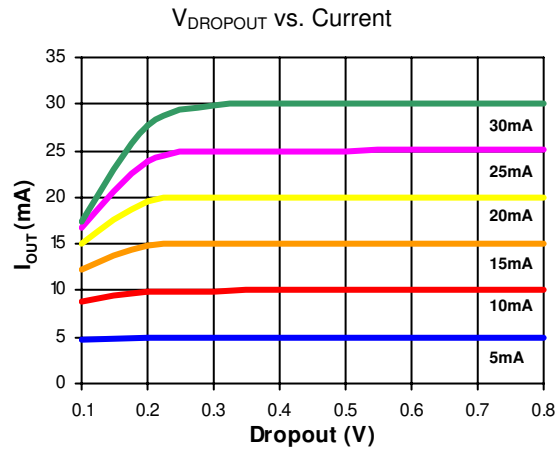
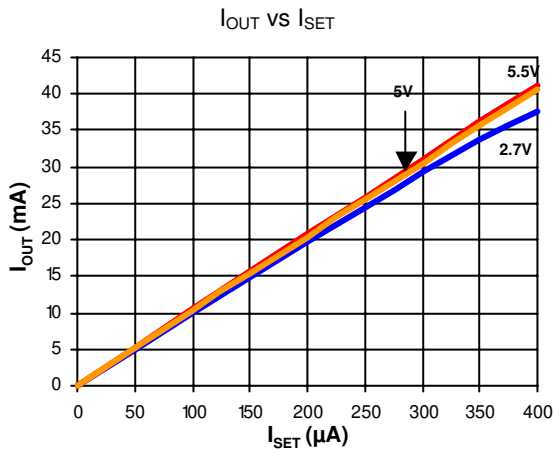
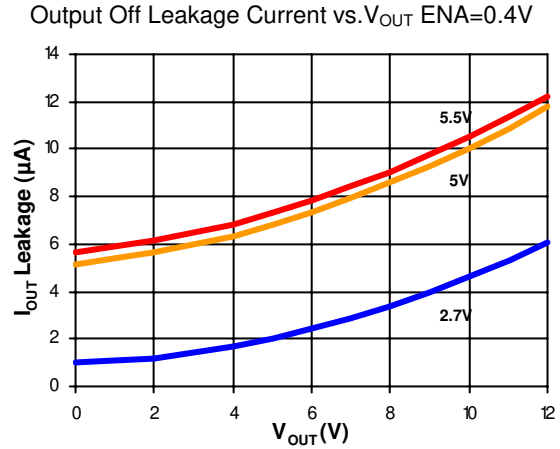
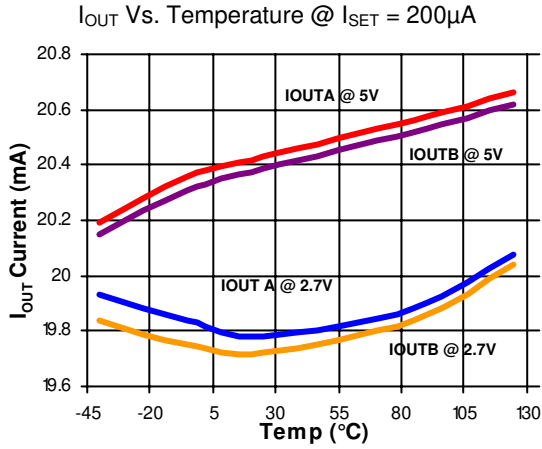

APPLICATIONS

**Figure 2** – Auto Dashboard or Instrument Front Panel LED Array

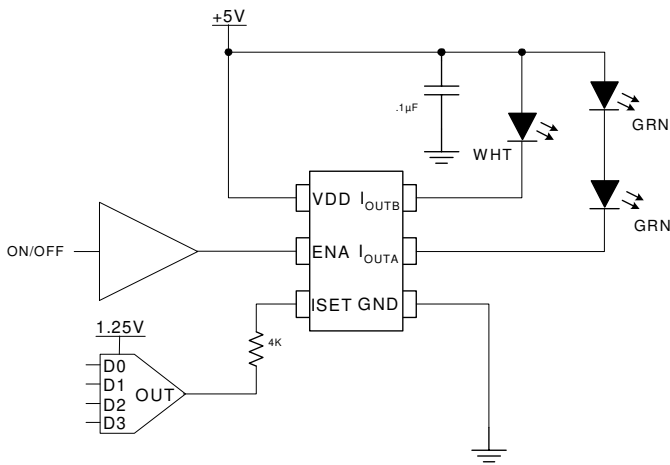
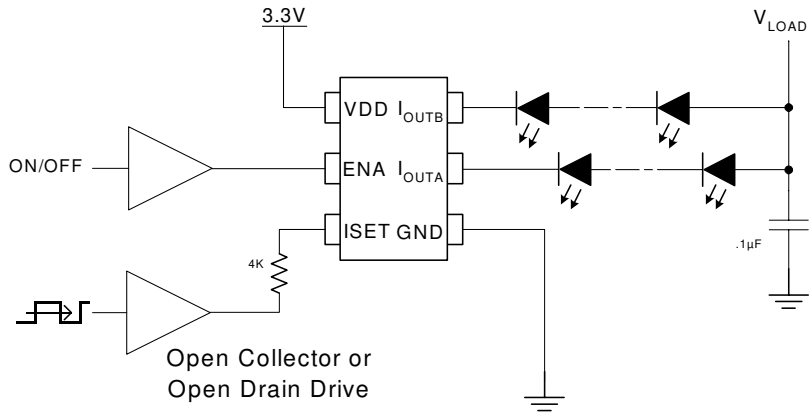

**Figure 3** – Color LCD Display & Keypad Illumination

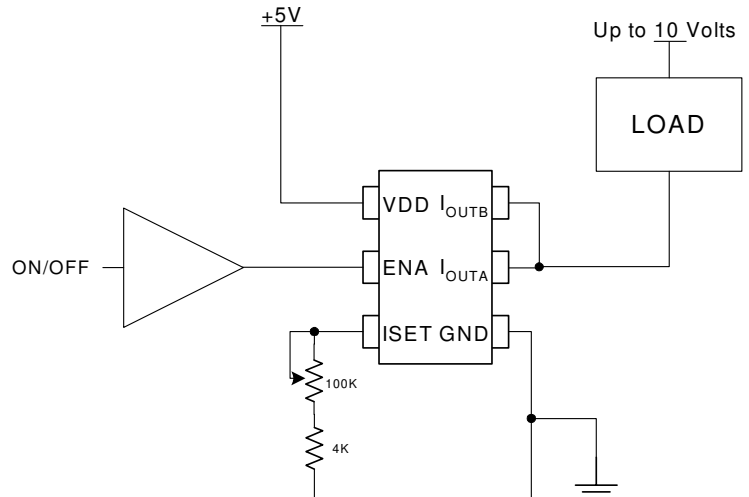

**Figure 4** – Variable Current Driver

DIMMING METHODS

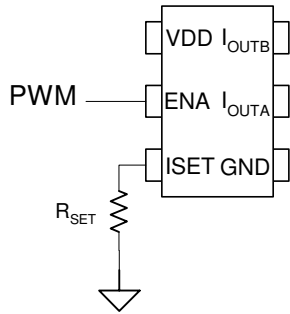

Figure 5 – PWM on Enabled (Lowest IQ)

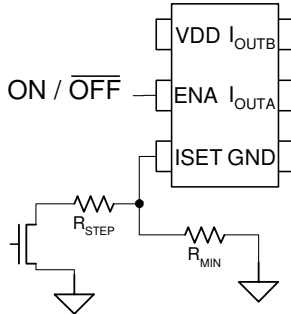

Figure 6 – Precision 2 Steps

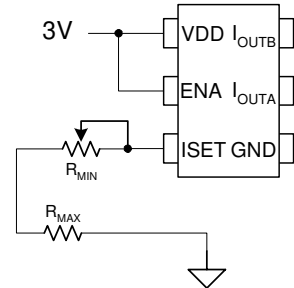

Figure 7 – Manual Control

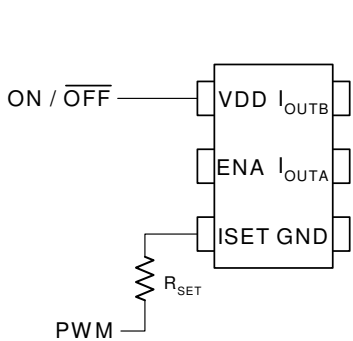

Figure 8 – PWM Dimming Totem Pole Output

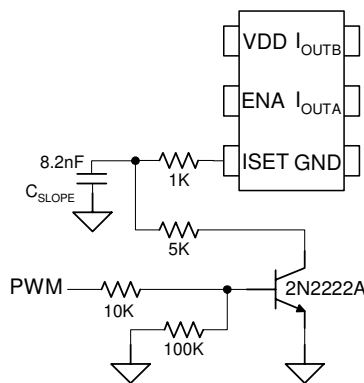

Figure 9 – PWM – Low EMI Wide Range

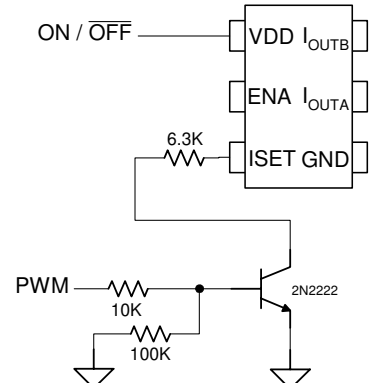
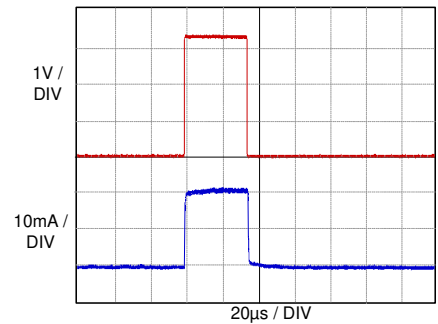
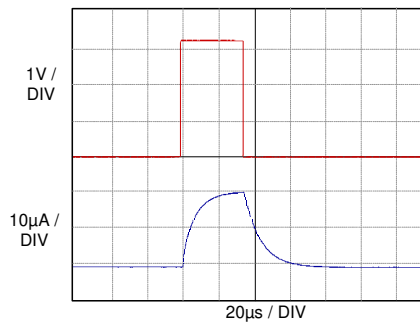
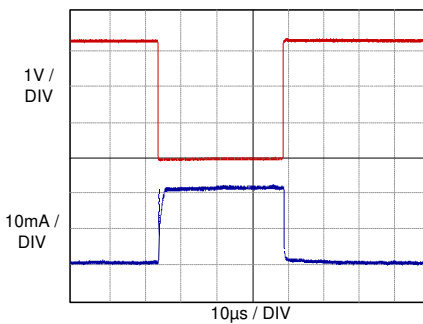
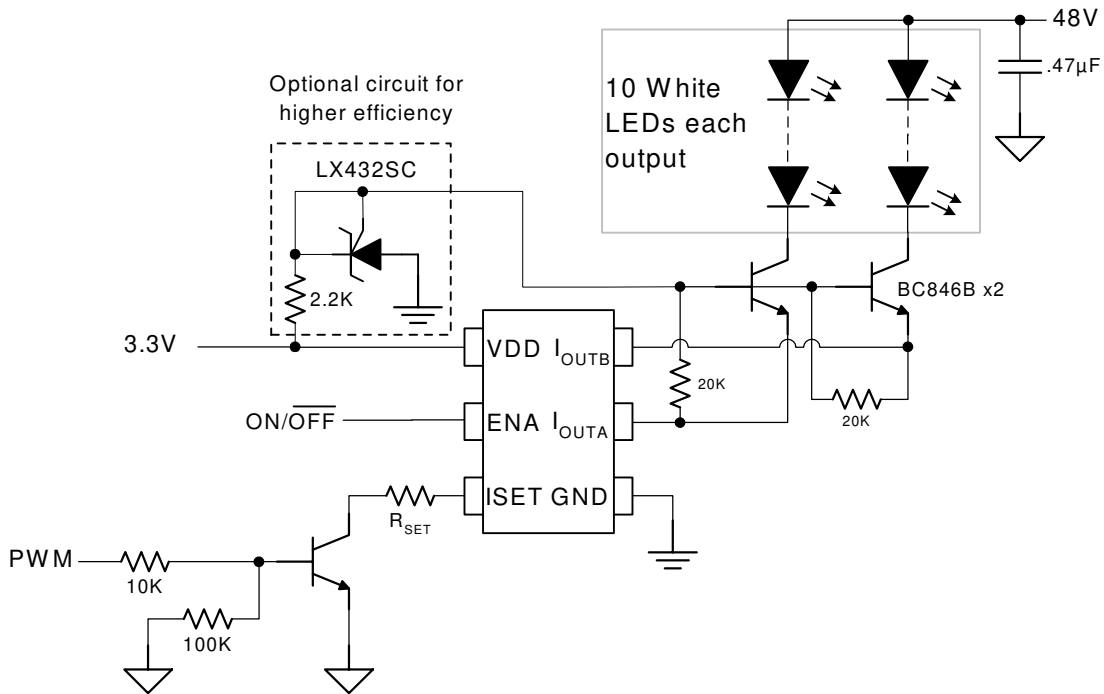

Figure 10 – PWM – Wide Range 500:1 +





**APPLICATION**

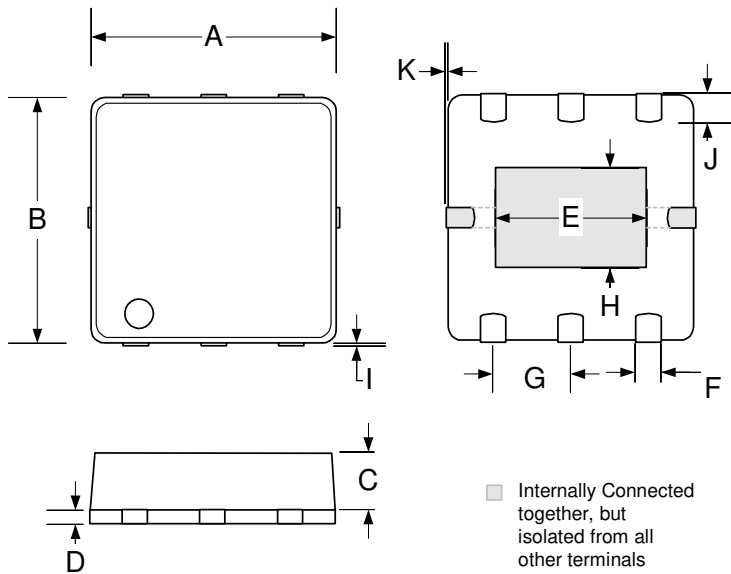

**Figure 11 – Using the LX1990 With High Voltage Supplies**

**PACKAGE DIMENSIONS**
**LM** 6-Pin Plastic MLP-Micro Exposed Pad

| Dim | MILLIMETERS |      | INCHES    |       |
|-----|-------------|------|-----------|-------|
|     | MIN         | MAX  | MIN       | MAX   |
| A   | 2.90        | 3.10 | 0.114     | 0.122 |
| B   | 2.90        | 3.10 | 0.114     | 0.122 |
| C   | 0.65        | 0.75 | 0.025     | 0.029 |
| D   | 0.15        | 0.25 | 0.005     | 0.009 |
| E   | 1.841 BSC   |      | 0.075 BSC |       |
| F   | 0.27        | 0.43 | 0.010     | 0.016 |
| G   | 0.95 BSC    |      | 0.037 BSC |       |
| H   | 1.22 BSC    |      | 0.048 BSC |       |
| I   | 0           | 0.10 | 0         | 0.003 |
| J   | 0.21        | 0.37 | 0.008     | 0.014 |
| K   | 0           | 0.10 | 0         | 0.003 |

**Note:**

- Dimensions do not include mold flash or protrusions; these shall not exceed 0.155mm(.006") on any side. Lead dimension shall not include solder coverage.

NOTES

PRODUCTION DATA – Information contained in this document is proprietary to Microsemi and is current as of publication date. This document may not be modified in any way without the express written consent of Microsemi. Product processing does not necessarily include testing of all parameters. Microsemi reserves the right to change the configuration and performance of the product and to discontinue product at any time.