

MX P/N	ADAPTER COLOR	KEY ORIENTATION
106181-0000	BLACK	OPPOSED*
106181-0100	GRAY	ALIGNED

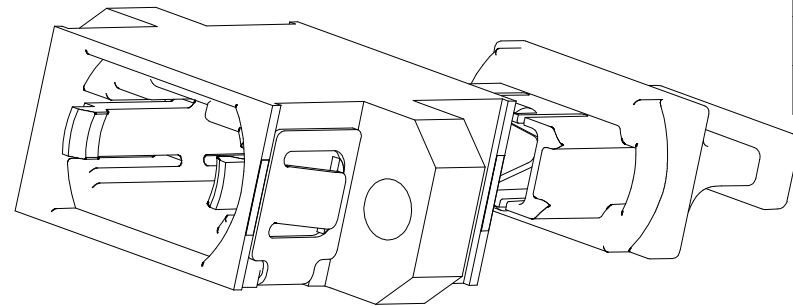

TWO DUST CAPS ARE PROVIDED

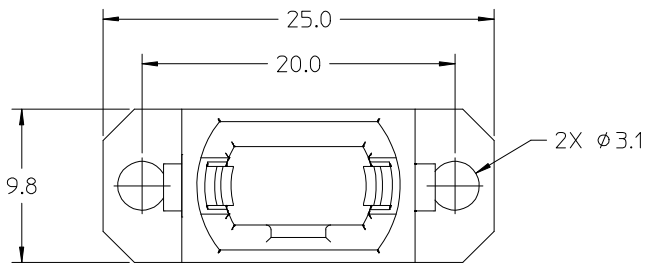
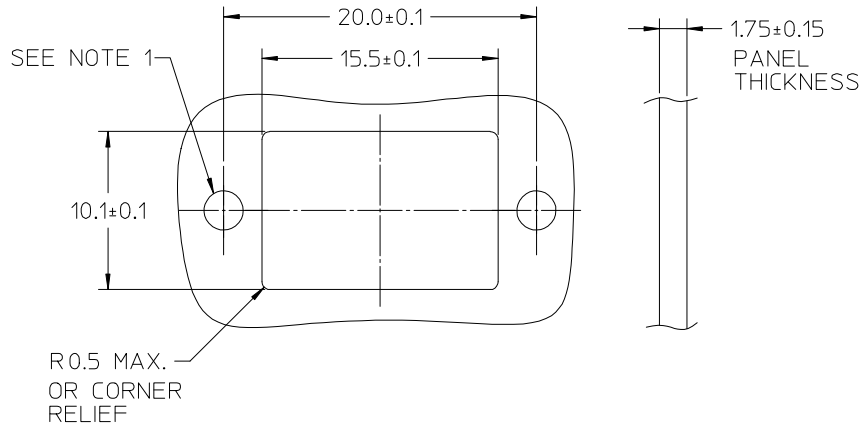
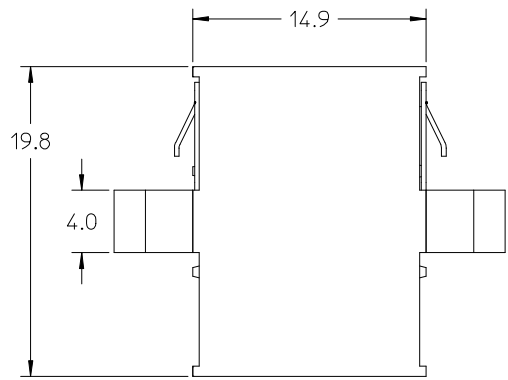

RECOMMENDED MOUNTING CUTOUT

- NOTES:
- RECOMMEND USE OF M2.5 OR 4-40 SCREW AND NUT (NOT PROVIDED).
RECOMMEND 2in-lbf TORQUE FOR SCREW MOUNT APPLICATIONS.
 - *"OPPOSED" KEY ORIENTATION IS THE STANDARD FOR MTP.
 - MATERIALS:
ADAPTER BODY - POLYETHERIMIDE
FLAMMABILITY - UL94 V-0
SPRING CLIP - STAINLESS STEEL
DUST PLUG - POLYCARBONATE:
SURFACE RESISTIVITY - <1E12 ohm/sq
TML - <1%
FLAMMABILITY - UL94 V-0

ENTER DESCRIPTION EC NO: MF2010-0164 DRWN: LGUMIN 2009/10/12 CHKD: LGUMIN 2009/10/12 APPR: LGUMIN 2009/10/12 REV B	QUALITY SYMBOLS	GENERAL TOLERANCES (UNLESS SPECIFIED)	DIMENSION STYLE	SCALE	DESIGN UNITS	THIRD ANGLE PROJECTION	
	▽=0 ∇=0	mm INCH 4 PLACES ± --- ± --- 3 PLACES ± --- ± --- 2 PLACES ± --- ± --- 1 PLACE ± --- ± --- ANGULAR ±1/2°	MM ONLY	---	INCH	DRAWN BY KP DATE 2006/07/07 CHECKED BY DATE APPROVED BY ILG DATE 2006/07/07 MATERIAL NO. SEE TABLE DOCUMENT NO. SD-106181-0000	MTP ADAPTER FULL FLANGE MOLEX INCORPORATED SHEET NO. 1 OF 1
	DRAFT WHERE APPLICABLE MUST REMAIN WITHIN DIMENSIONS		THIS DRAWING CONTAINS INFORMATION THAT IS PROPRIETARY TO MOLEX INCORPORATED AND SHOULD NOT BE USED WITHOUT WRITTEN PERMISSION				
			SIZE B				