

# DIODE MODULE (F.R.D.)

# FRS300BA50

UL;E76102(M)

FRS300BA is a high speed (fast recovery) isolated diode module designed for high power switching application. FRS300BA is suitable for high frequency application requiring low loss and high speed control.

- High Speed  $t_{rr} \leq 200\text{ns}$
- $I_{F(AV)}$  300A
- Isolated Mounting base.
- High Surge Capability

**(Applications)**

- Inverter Welding Power Supply
- Power Supply for Telecommunication
- Various Switching Power Supply.

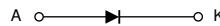
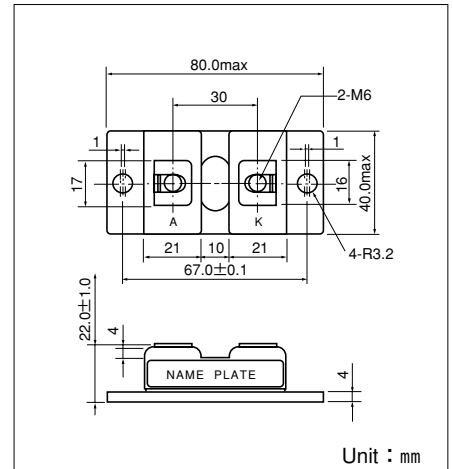

**Maximum Ratings**

( $T_j=25^\circ\text{C}$  unless otherwise specified)

Symbol	Item	Ratings		Unit
		FRS300BA50		
$V_{RRM}$	Repetitive Peak Reverse Voltage	500		V
$V_{R(DC)}$	D.C. Reverse Voltage	400		V

Symbol	Item	Conditions	Ratings	Unit	
$I_{F(AV)}$	Forward Current	D.C. $T_c : 85^\circ\text{C}$	300	A	
$I_{FMS}$	Surge Forward Current	$1/2$ cycle, 60Hz, peak value, non-repetitive	4000	A	
$I_t$	$I_t$	Value for one cycle of surge current	66600	$\text{A}\cdot\text{S}$	
$T_j$	Operating Junction Temperature		-40 to +150	$^\circ\text{C}$	
$T_{stg}$	Storage Temperature		-40 to +125	$^\circ\text{C}$	
$V_{iso}$	Isolation Breakdown Voltage (R.M.S.)	A.C. 1 minute	2500	V	
	Mounting Torque	Mounting (M6)	Recommended Value 2.5-3.9 (25-40)	4.7 (48)	N·m (kgf·cm)
		Terminal (M6)	Recommended Value 2.5-3.9 (25-40)	4.7 (48)	
	Mass	Typical Value	170	g	

**Electrical Characteristics**

Symbol	Item	Conditions	Ratings			Unit
			Min.	Typ.	Max.	
$I_{RRM}$	Repetitive Peak Reverse Current	$T_j=125^\circ\text{C}$ , $V_{RRM}=500\text{V}$			300	mA
$V_{FM}$	Forward Voltage Drop	$T_j=25^\circ\text{C}$ , $I_{FM}=300\text{A}$ , Inst. measurement			1.3	V
$t_{rr}$	Reverse Recovery Time	$I_F=300\text{A}$ , $-di/dt=300\text{A}/\mu\text{s}$			200	ns
$R_{th(j-c)}$	Thermal Impedance	Junction to case			0.165	$^\circ\text{C}/\text{W}$

