

REVISIONS				
P	LTR	DESCRIPTION	DATE	APP'D
A2		REVISED PER ECO-17-011927	22AUG2017	RS KR

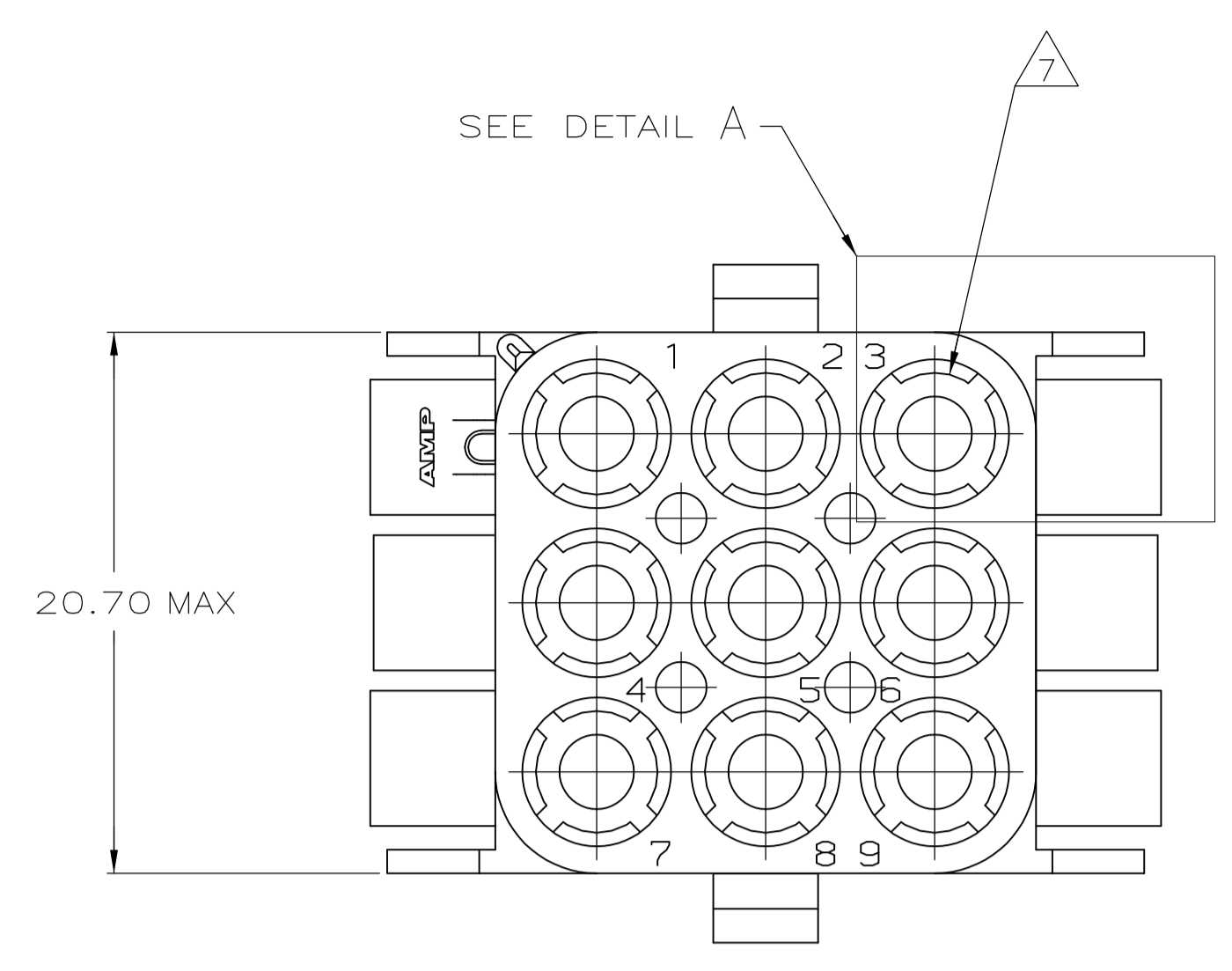

- 1 MATES WITH APPROPRIATE UNIVERSAL MATE-N-LOK™ PLUG.
- 2 RECOMMENDED PANEL THICKNESS 0.76 - 2.29.
- 3 PANEL MUST BE PUNCHED SO THAT THE HOUSING ENTERS THE PANEL IN THE SAME DIRECTION AS THE PUNCH.
- 4 OPTIONAL FOR KEYING HOUSING IN PANEL.
- 5 CIRCUIT NUMBER 1 LOCATION.
- 6 UNDERWRITER RECOGNIZED COMPONENT LOGO AND CSA CERTIFICATION LOGO TO BE LOCATED ONCE EACH SIDE ON SIDE OF HOUSING.
- 7 FOUR RIBS EQUALLY SPACED, NO SPECIFIC ORIENTATION. NO RIBS OR SIX RIBS EQUALLY SPACED, NO SPECIFIC ORIENTATION, OPTIONAL.
- 8 150° C TEMPERATURE RATING FOR THIS HOUSING IS FOR SHORT TERM DURATION. MAX OPERATING TEMPERATURE REMAINS 125° C.
- 9 PHOSPHOR BRONZE CONTACTS SHOULD ALWAYS BE USED WITH THIS HOUSING.
- 10 DIMENSIONS SHOWN REPRESENT PRODUCT IN DRY, AS MOLDED CONDITION ADDITIONAL 2% GROWTH DUE TO SUBSEQUENT MOISTURE ABSORPTION MAY OCCUR AND SHOULD BE ACCOUNTED FOR.

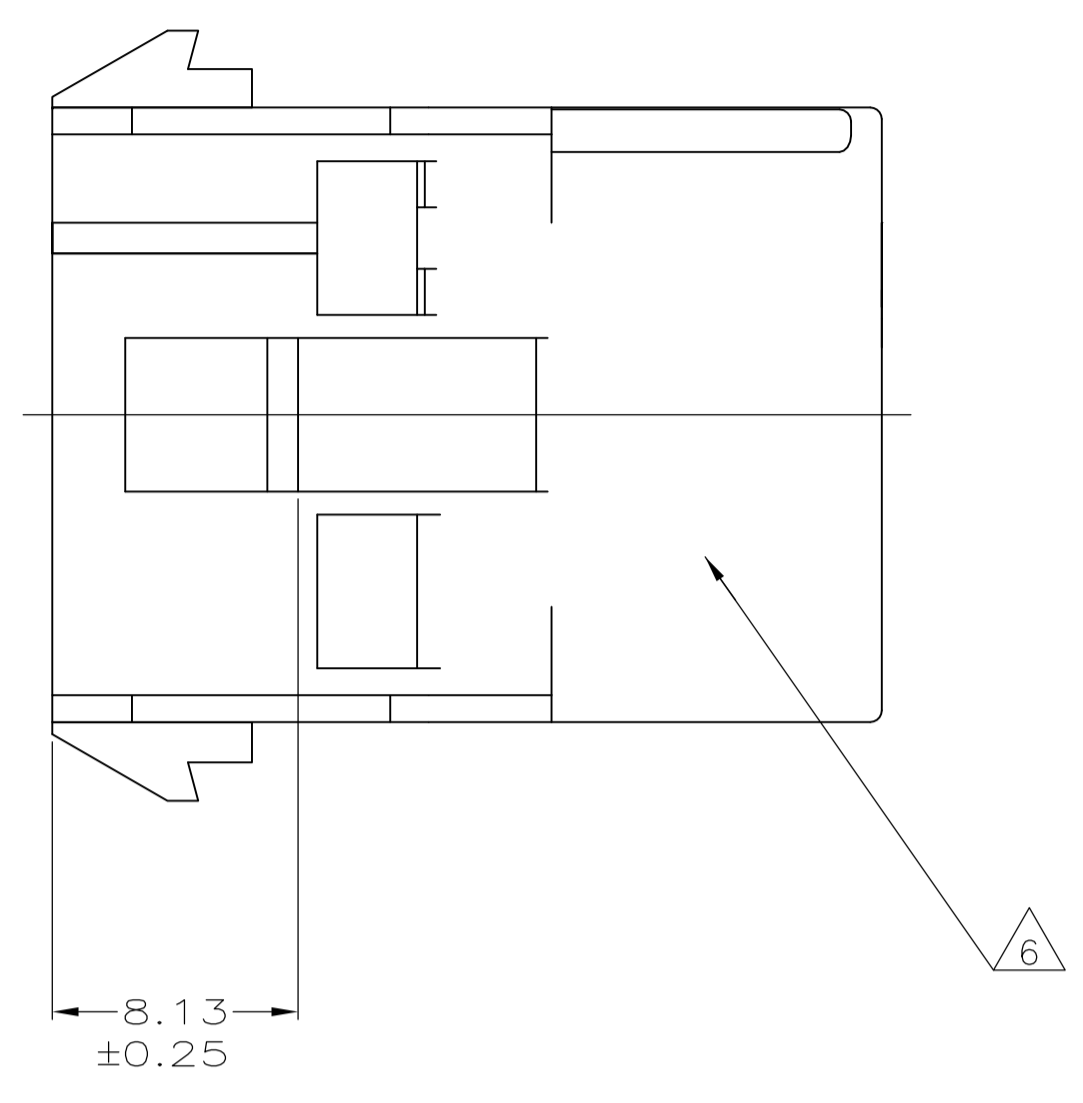
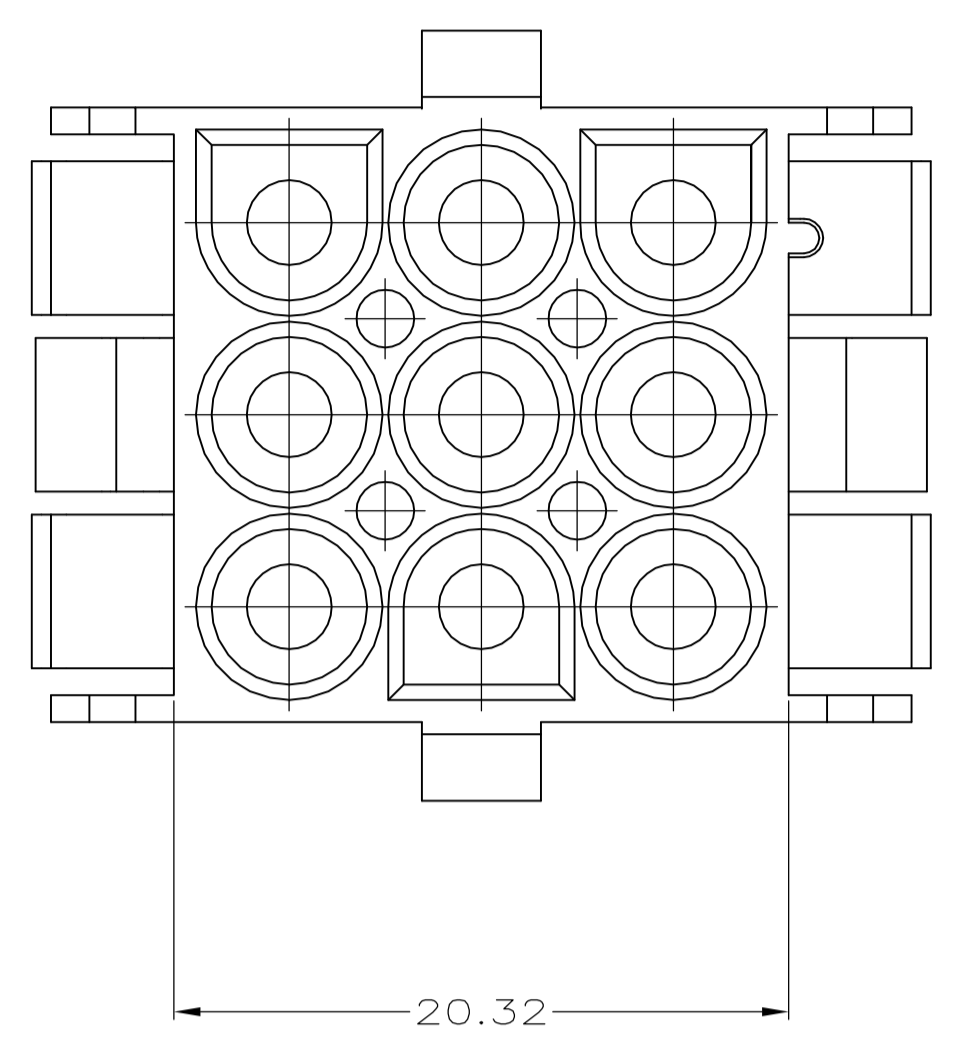
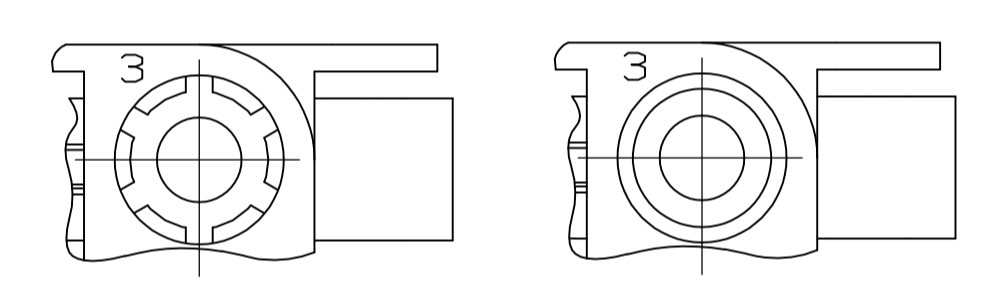

DETAIL A
OPTIONAL CONSTRUCTIONS

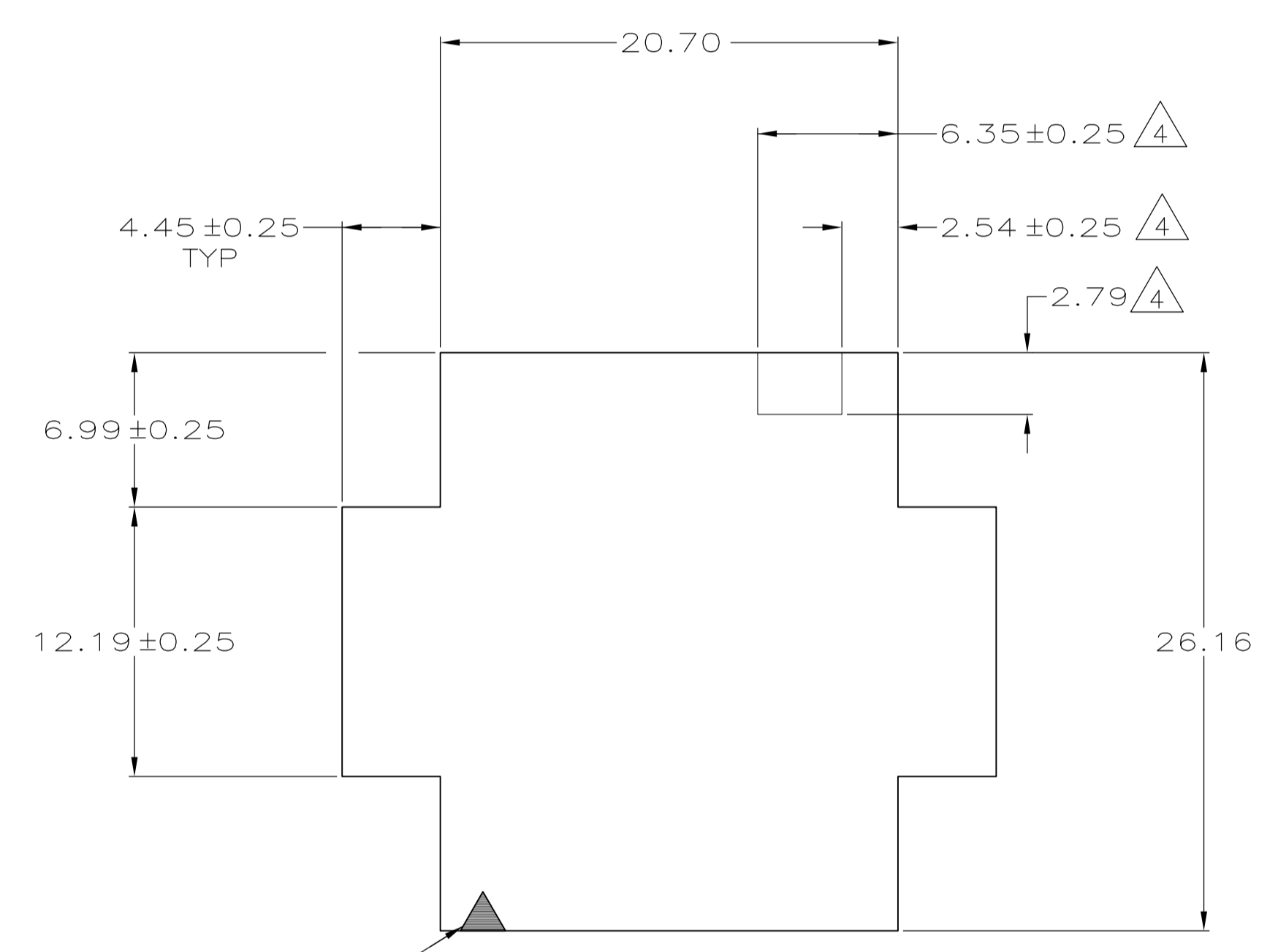
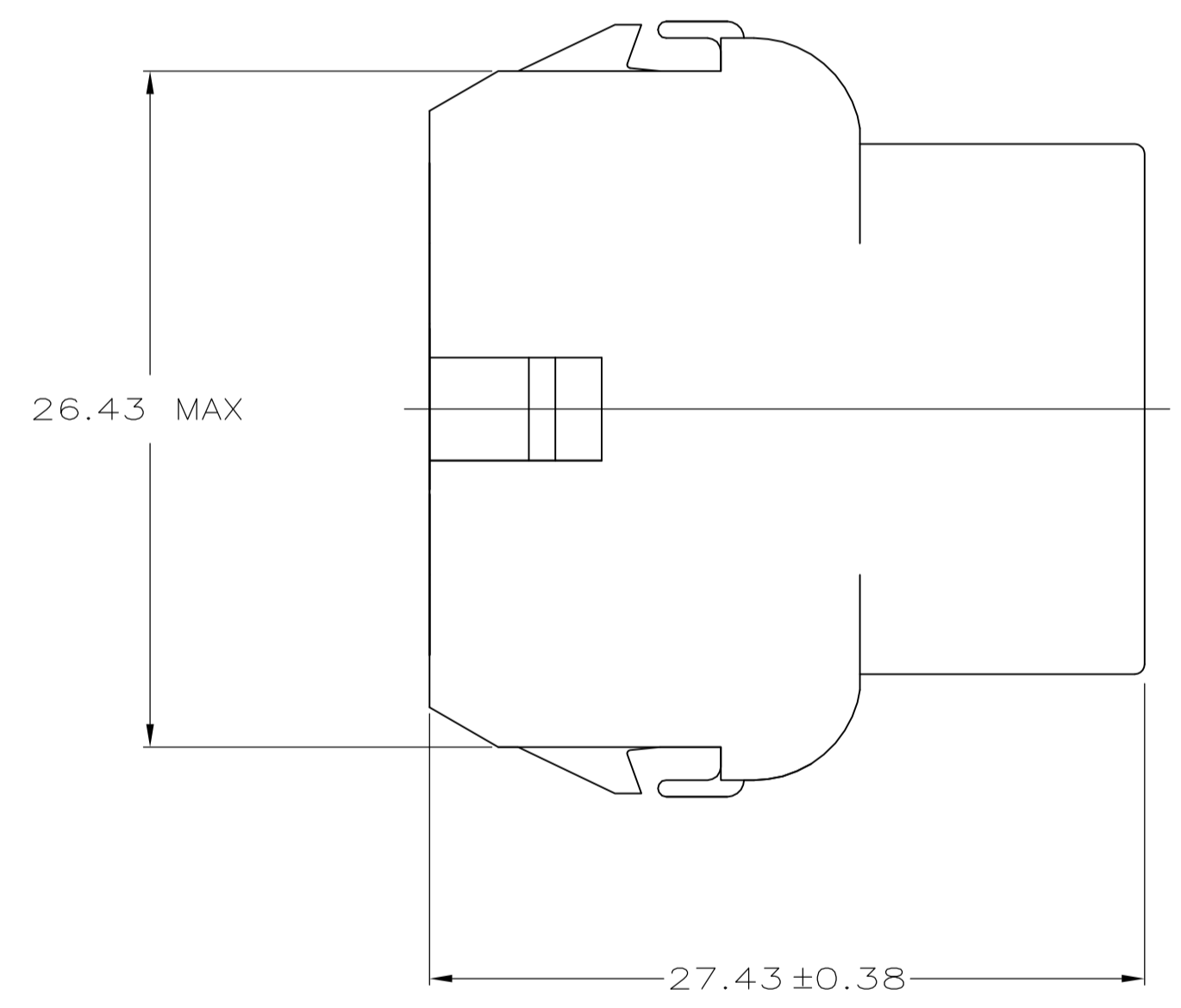

RECOMMENDED PANEL CUT OUT

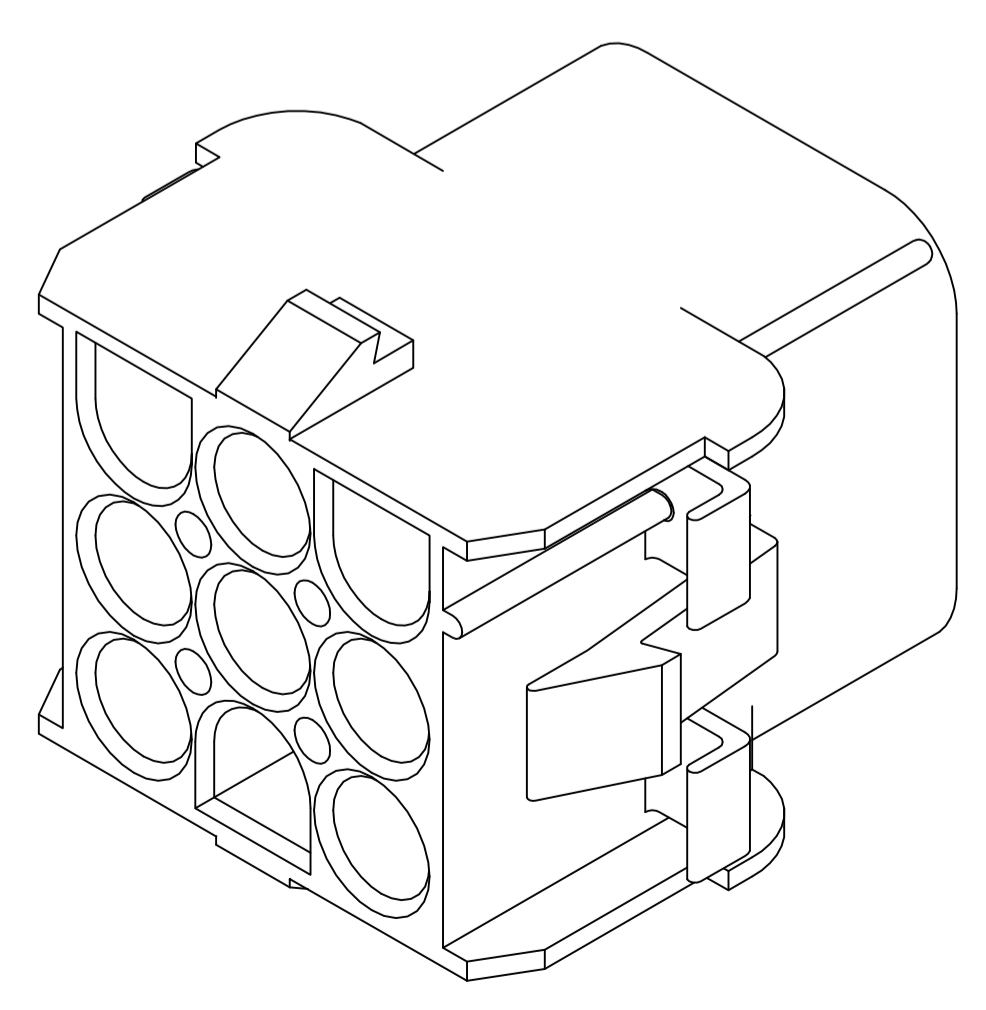

3-DIMENSIONAL MODEL
NTS

6.35	.250	-	-
4.45	.175	27.43	1.080
2.79	.110	26.43	1.041
2.54	.100	26.16	1.030
2.29	.090	20.70	.815
0.76	.030	20.32	.800
0.38	.015	12.19	.480
0.25	.010	8.13	.320
0.13	.005	6.99	.275
MM	IN	MM	IN

CONVERSION TABLE

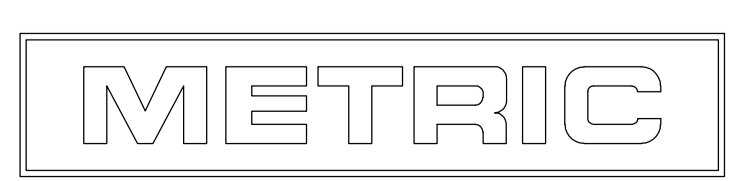

THIS DRAWING IS A CONTROLLED DOCUMENT.

DIMENSIONS: mm	TOLERANCES UNLESS OTHERWISE SPECIFIED: 0. PLC ± - 1. PLC ± - 2. PLC ± 0.13 3. PLC ± - 4. PLC ± - ANGLES ± 0° 30'	FINISH -	MATERIAL NYLON, UL 94V-2, BLACK
-------------------	--	----------	---------------------------------

DIN K. WHITAKER 18-NOV-1998	CHK R. SWING 18-NOV-1998	APP'D D. SELF 18-NOV-1998	NAME
CAP, 9 CIRCUIT, UNIVERSAL MATE-N-LOK™			RESTRICTED TO
SIZE A1	SCALE 4:1	SHEET 1 of 1	REV A2

CUSTOMER DRAWING

794538-1
PART NUMBER