

Multifunction IC for engine management system

Datasheet - production data

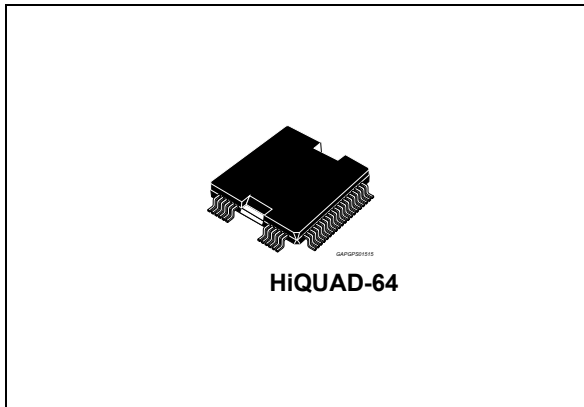

Features

- 5 V logic regulator
- 3.3 V logic regulator
- 5 V tracking sensor supply
- Smart reset function
- Power latch with Secure Engine Off (SEO) functionality, to safely complete driver switch off procedure
- Flying wheel interface function (VRS) with adaptive time and amplitude control
- Protected low-side relay driver
 - OUT13 to 18, MRD
- Protected low-side (injector drivers)
 - OUT1 to 4
- Protected low-side (high current)
 - OUT5, 6, 7
- Protected low-side (low current)
 - OUT20
- IGBT pre-drivers (IGN1 to 4) with parallel input
- Parallel input IN1 to IN7 to drive OUT1 to OUT7
- Configurable power stages CPS
 - Stepper motor driver/ high-side - low-side (OUTA to D)
- Thermal warning and shutdown
- Serial interface
 - SPI 16-bit frame
 - ISO9141 interface (K-Line)
- High speed CAN transceiver
- VDA 2.0 compliance with 3 level Watchdog
- Package: HiQUAD-64

Description

The L9779WD-SPI is an integrated circuit designed for automotive environment and implemented in BCD6S technology.

It is conceived to provide all basic functions for standard engine management control units.

It is assembled in the HiQUAD-64 power package.

Table 1. Device summary

Order code	Package	Packing
L9779WD-SPI	HiQUAD-64	Tray
L9779WD-SPI-TR	HiQUAD-64	Tape and Reel

Contents

- 1 Detailed features description 9**
- 2 Block diagram 11**
- 3 Pins description 12**
- 4 Application schematic 16**
- 5 Absolute maximum ratings 17**
 - 5.1 ESD protection 18
 - 5.2 Latch-up test 19
 - 5.3 Temperature ranges and thermal data 19
 - 5.4 Operating range 19
 - 5.4.1 Low battery 19
 - 5.4.2 Normal battery 19
 - 5.4.3 High battery 19
 - 5.4.4 Load dump 19
- 6 Functional description 20**
 - 6.1 Ignition switch, main relay, battery pin 20
 - 6.2 Power-up/down management unit 21
 - 6.2.1 Power-up sequence 21
 - 6.2.2 Power-down sequence 23
 - 6.3 Smart reset circuit 29
 - 6.3.1 Smart reset circuit functionality description 29
 - 6.4 Thermal shut down 33
 - 6.5 Voltage regulators 34
 - 6.6 Charge pump 40
 - 6.7 Main relay driver 44
 - 6.7.1 Main relay driver functionality description 44
 - 6.7.2 MRD scenarios 45
 - 6.8 Low-side switch function (LSa, LSb, LSd) 50
 - 6.8.1 LSa function OUT 1 to 5 (Injectors) 50

6.8.2	LSb function OUT6, 7 (O2 heater)	53
6.8.3	LSc function OUT20 (low current drivers)	55
6.8.4	LSd function OUT13 to 18 (relay drivers)	57
6.9	LSa, LSb, LSc, LSd diagnosis	62
6.10	Ignition pre-drivers (IGN1 to 4)	64
6.10.1	Ignition pre-drivers functionality description	65
6.10.2	Ignition pre-driver diagnosis	66
6.11	Configurable power stages (CPS) (OUTA to OUTD)	67
6.11.1	Configurable power stages functionality description	67
6.11.2	Diagnosis of configurable power stages (CPS)	71
6.11.3	Diagnosis of CPS [OUTA to OUTD] when configured as H-bridges	71
6.11.4	Diagnosis of CPS OUTA, B, C, D when configured as single low side power stages	76
6.12	ISO serial line (K-LINE)	80
6.12.1	ISO serial line (K-LINE) functionality description	80
6.13	CAN transceiver	83
6.13.1	CAN transceiver functionality description	83
6.14	Flying wheel interface function	88
6.14.1	Flying wheel interface functionality description	88
6.14.2	Auto-adaptive sensor filter	88
6.14.3	Application circuits	93
6.14.4	Diagnosis test	96
6.15	Monitoring module (watchdog)	98
6.15.1	WDA - Watchdog (algorithmic)	98
6.15.2	Monitoring module - WDA Functionality	99
6.16	Serial interface	108
6.16.1	SPI interface	108
6.16.2	SPI protocol	108
6.16.3	SPI registers	110
	CONFIG_REG1	114
	CONFIG_REG2	114
	CONFIG_REG3	115
	CONFIG_REG4	116
	CONFIG_REG5	117
	CONFIG_REG6	118
	CONFIG_REG7	119
	WD_ANSW/WDA RESP/CONFIG_REG8	120

	CONFIG_REG9/SPI RESPTIME	120
	CONFIG_REG10 (CPS Configuration register)	121
	IDENT_REG/DIA_REG[1:5]	121
	DIA_REG6	124
	DIA_REG7	125
	DIA_REG8	126
	DIA_REG9	127
	DIA_REG10	128
	DIA_REG11	129
	DIA_REG12	130
	DIA_REG13/WDA_RESPTIME	131
	DIA_REG14/REQULO	131
	DIA_REG15/REQUHI	132
	DIAG_REG16/RST_AB1_CNT	133
	CONTR_REG1	134
	CONTR_REG2	135
	CONTR_REG3	136
	CONTR_REG4	137
7	Package information	138
7.1	HiQUAD-64 package information	138
8	Revision history	140

List of tables

Table 1.	Device summary	1
Table 2.	Pins description	12
Table 3.	Absolute maximum ratings	17
Table 4.	ESD protection	18
Table 5.	Temperature ranges and thermal data	19
Table 6.	Operating range	19
Table 7.	KEY_ON pin electrical characteristics	28
Table 8.	Internal reset	30
Table 9.	RST pin external components required	32
Table 10.	RST pin electrical characteristics	32
Table 11.	Temperature information	33
Table 12.	Voltage regulators external components required	35
Table 13.	VB Power supply electrical characteristics	37
Table 14.	Linear 5 V regulator electrical characteristics	38
Table 15.	Linear 3.3 V regulator electrical characteristics	42
Table 16.	5V tracking sensor supply electrical characteristics	43
Table 17.	Main relay driver electrical characteristics	45
Table 18.	LSa electrical characteristics	50
Table 19.	LSa diagnosis electrical characteristics	52
Table 20.	LSa diagnosis electrical characteristics (OUT 5)	52
Table 21.	LSb electrical characteristics	53
Table 22.	LSb diagnosis electrical characteristics	54
Table 23.	LSc electrical characteristics	55
Table 24.	LSc diagnosis electrical characteristics	56
Table 25.	LSd electrical characteristics	57
Table 26.	LSd diagnosis electrical characteristics	58
Table 27.	Fault encoding condition	63
Table 28.	Ignition pre-drivers electrical characteristics	65
Table 29.	Configuration of the stepper motor	68
Table 30.	Half bridge 1	69
Table 31.	Half bridge 2	70
Table 32.	Half bridge 3	70
Table 33.	Half bridge 4	70
Table 34.	Stepper configuration electrical characteristics	75
Table 35.	Electrical and diagnosis characteristics of OUTA, B, C, D when configured as single power stages	77
Table 36.	Electrical characteristics of OUTA, B, C, D when configured as single power stages connected in parallel	78
Table 37.	CPS table single mode parallelism	79
Table 38.	Three configurations of CONFIG_REG10 register	79
Table 39.	ISO serial line (K-LINE) functionality electrical characteristic	81
Table 40.	CAN transceiver electrical characteristics	84
Table 41.	CAN transceiver timing characteristics	86
Table 42.	Pick voltage detector precision	90
Table 43.	Hysteresis threshold precision	90
Table 44.	SPI command possible configuration of different option of VRS function	92
Table 45.	VRs typical characteristics	94
Table 46.	Diagnosis test electrical characteristics	96

Table 47.	WDA_INT electrical characteristics	98
Table 48.	Error counter	102
Table 49.	State for <INIT_WDR> = 1	103
Table 50.	Reset-behaviour of <WDA_INT>, AB1 and <WD_RST>	104
Table 51.	Expected responses	105
Table 52.	Reset behaviour	106
Table 53.	Timing characteristics	109
Table 54.	Electrical characteristics	110
Table 55.	SPI registers	110
Table 56.	CLOCK_UNLOCK_SW_RST	112
Table 57.	START_REACT	112
Table 58.	HiQUAD-64 package mechanical data	139
Table 59.	Document revision history	140

List of figures

Figure 1.	Block diagram	11
Figure 2.	Pins connection diagram (top view)	12
Figure 3.	Application schematic	16
Figure 4.	Configuration supplied by VB	20
Figure 5.	Power-up/down management unit	21
Figure 6.	Non-permanent supply power-up sequence	21
Figure 7.	Permanent supply power-up sequence	22
Figure 8.	Power-down sequence without power latch mode	24
Figure 9.	Power-down sequence without power latch mode and PSOFF = 1	25
Figure 10.	Power-down sequence with power latch mode	26
Figure 11.	Power-down sequence with power latch mode and KEY_ON toggle	27
Figure 12.	KEY_ON voltage vs. status diagram	28
Figure 13.	Smart reset circuit	29
Figure 14.	RST pin as a function of VDD5 (if CONFIG_REG6 bit3 = Low)	32
Figure 15.	Structure regulators diagram	34
Figure 16.	Graphic representation of the calculation method	35
Figure 17.	Circuit and PCB layout suggested	36
Figure 18.	VB overvoltage diagram	38
Figure 19.	VDD5 overvoltage diagram	40
Figure 20.	VDD5 vs battery: ramp-up diagram	41
Figure 21.	VDD5 vs battery (ramp-down diagram)	41
Figure 22.	Main relay driver controlled by L9779WD-SPI	44
Figure 23.	Scenario 1a: Standard on/off MRD driver with NO power latch mode bit PSOFF = 0	45
Figure 24.	Scenario 1b: Standard on/off MRD driver with NO power latch mode bit PSOFF = 1	46
Figure 25.	Scenario 2: Standard on/off MRD driver with power latch mode bit PSOFF = 0	46
Figure 26.	Scenario 3a: Deglitch concept on KEY_ON at start-up	46
Figure 27.	Scenario 3b: Deglitch concept on KEY_ON during ON phase	47
Figure 28.	Scenario 4: Non standard on, KEY_ON removed before VB present	47
Figure 29.	Scenario 5: MRD overcurrent without VB	47
Figure 30.	Scenario 6: permanent MRD overcurrent with VB POR restart	48
Figure 31.	Scenario 7 (temporary MRD overcurrent with VB POR restart)	48
Figure 32.	Scenario 8 (temporary MRD overcurrent with VB μ C commands restart)	49
Figure 33.	LSa function OUT 1 to 5 (Injectors)	50
Figure 34.	LSb function OUT6, 7 (O2 heater)	53
Figure 35.	LSc function OUT20 (low current drivers)	55
Figure 36.	LSd function OUT13 to 18 (relay drivers)	57
Figure 37.	Behavior of OUT13, 14, 21, 25 with VB = VB_UV for a time shorter than Thold and with a valid ON condition	59
Figure 38.	Behavior of OUT13, 14, 21, 25 with VB = UB_UV for a time longer than Thold and with a valid ON condition	60
Figure 39.	Behavior of OUT13, 14, 21, 25 with VB that drops lower than POR threshold during cranking	61
Figure 40.	LSx diagnosis circuit	63
Figure 41.	Fault encoding condition diagram	63
Figure 42.	LSx ON/OFF slew rate control diagram	64
Figure 43.	Ignition-pre drivers (IGN1 to 4) circuit	64
Figure 44.	Ignition-pre drivers (IGN1 to 4) diagram	66
Figure 45.	Stepper motor operation diagram	69

Figure 46.	Stepper motor driver: H-bridge1	70
Figure 47.	Stepper motor driver: H-bridge2	70
Figure 48.	Stepper motor driver "off" diagnosis time diagram	72
Figure 49.	Stepper motor driver diagnosis I-V relationship diagram	73
Figure 50.	Open load detection during "on" phase	74
Figure 51.	Open load detection during "on" phase	74
Figure 52.	Short to GND detection during "on" phase	75
Figure 53.	ISO serial line (K-LINE) circuit	80
Figure 54.	ISO serial line switching waveform	82
Figure 55.	ISO serial line: short circuit protection	82
Figure 56.	CAN transceiver diagram	83
Figure 57.	CAN transceiver switching waveforms	87
Figure 58.	CAN transceiver test circuit	87
Figure 59.	Flying wheel interface circuit.	88
Figure 60.	Auto adaptative hysteresis diagram	89
Figure 61.	VRS interface block diagram	89
Figure 62.	Auto-adaptive time filter (rising edge)	91
Figure 63.	Adaptive filter function when the SPI bit are 00 or 01	91
Figure 64.	Adaptive Filter Function when the SPI bit are 10 or 11	92
Figure 65.	Variable reluctance sensor	93
Figure 66.	VRs typical characteristics	93
Figure 67.	Hall effect sensor configuration 1	94
Figure 68.	Hall effect sensor configuration 2	95
Figure 69.	Diagnosis test diagram	96
Figure 70.	WDA block diagram	99
Figure 71.	Monitoring cycle diagram	100
Figure 72.	4-bit Markov chain diagram	101
Figure 73.	Timing characteristics diagram	109
Figure 74.	HiQUAD-64 package outline	138

1 Detailed features description

- Package
 - HiQUAD-64
- 5 V logic regulator
 - 5 V precision voltage regulator ($\pm 2\%$) with external NMOS
 - Max current regulated: 400 mA
 - Charge pump capacitor at pin CP is used to drive the gate of the external NMOS transistor
- 3.3 V logic regulator
 - 3.3 V precision voltage regulator ($\pm 2\%$) with over-current protection
 - Max current regulated: 100 mA
- 5 V tracking sensor supply
 - 2 x 5 V tracking sensor supply with protection and diagnosis on SPI
 - Short-circuit to Vbat/GND fully protected
 - Max current regulated: 2 x 100 mA
- Smart reset
 - Main Reset monitoring VB_UV Logic voltage management and safety control
- Watch dog
 - Main reset management 5 V voltage monitoring safety output disable
 - SPI controllable query and answer watch dog compliant with VDA2.0 level 3 (enabled by default)
- Power latch
 - L9779WD-SPI is switched on by KEY_ON signal and switched off by logic OR of KEY_ON signal and SPI bit
- Secure engine off mode (default) switches off the drivers in the following order:
 - OUT1 through to OUT4 in 225 ms (typical)
 - OUT13 and OUT14 in 600 ms (typical)
- Flying wheel interface function (VRS)
 - The VRS is the interface between the microprocessor and the magnetic pick-up or variable reluctance sensor that collects the information coming from the flying wheel
 - Adaptive filtering on amplitude and timing adapts better the device response to VRS input switching
- Protected low-side driver
 - LSa (OUT1 to 5)
 - 4 Ch. serial IN via SPI and parallel IN, $R_{dson} = 0.72 \text{ Ohm @}150^\circ\text{C}$, $V_{cl} = 58 \text{ V } \pm 5$, $I_{max} = 2.2 \text{ A}$;
 - 1 Ch. serial IN via SPI and parallel IN, $R_{dson} = 0.72 \text{ Ohm @}150^\circ\text{C}$, $V_{cl} = 58 \text{ V } \pm 5$, $I_{max} = 3 \text{ A}$;
 - LSb (OUT6, 7)
 - 2 Ch. serial IN via SPI and parallel IN, $R_{dson} = 0.47 \text{ Ohm @}150^\circ\text{C}$, $V_{cl} = 45 \text{ V } \pm 5$, $I_{max} = 5 \text{ A}$

Full diagnosis on SPI (2 bit for each channel) and voltage slew rate control.

When an over current fault occurs, the driver switches off with faster slew rate in order to reduce the power dissipation.

- LSc (OUT20)
 - 1 Ch serial IN via SPI, $I_{max} = 50 \text{ mA}$

- LSD (OUT13 to 18, MRD)

6 Ch. serial IN via SPI, $R_{dson} = 1.5 \text{ Ohm @ } 150 \text{ }^\circ\text{C}$, $V_{cl} = 48 \text{ V}$, $I_{max} = 600 \text{ mA}$ (2 of them with low battery voltage function);

1 main relay driver $R_{dson} = 2.4 \text{ Ohm @ } 150 \text{ }^\circ\text{C}$, $V_{cl} = 48 \text{ V}$, $I_{max} = 600 \text{ mA}$

With full diagnosis on SPI (2 bit for each channel) and voltage slew-rate control.

When an over current fault occurs, the driver switches off with faster slew rate in order to reduce the power dissipation.

- Ignition pre-drivers (IGN1 to 4) with parallel input
 - 4 x ignition pre-drivers with full diagnostic.
- SPI
- 1 x Stepper motor driver designed for a double winding coil motor, used for engine idle speed control.

The stepper driver is made by 4 independent half bridgeS each one with:

- 1 high-side driver, $R_{dson} = 1.5 \text{ Ohm}$, $I_{max} = 600 \text{ mA}$
- 1 low-side driver, $R_{dson} = 1.5 \text{ Ohm}$, $I_{max} = 600 \text{ mA}$

The low-side drivers could be connected in parallel.

Low-side and high-side drivers implement voltage SR control to minimize emission.

Two high-side drivers have the low battery voltage function.

- Thermal shutdown
 - 1 x Thermal shutdown ($T_j > 175 \text{ }^\circ\text{C} = T_{sd}$) if $T_j > T_{sd}$: VTRK1, 2 are turned off.
 - 1 x Thermal shutdown ($T_j > 175 \text{ }^\circ\text{C} = T_{sd}$) if $T_j > T_{sd}$: OUT1 to 10, OUT13 to 20, OUTA to D, IGN1 to 4 are turned off.
 - 1 x Thermal Shutdown ($T_j > 175 \text{ }^\circ\text{C} = T_{sd}$) if $T_j > T_{sd}$: V3V3 is turned off.
 - 1 x Thermal shutdown ($T_j > 175 \text{ }^\circ\text{C} = T_{sd}$) if $T_j > T_{sd}$: MRD is turned off (if battery present).

There are 5 temperature sensors for OT2 (OUT1..10, OUT13...20, OUT21...28, IGN1...4 are turned off) in different Layout position, they are logically "AND" in case of thermal shutdown.

- ISO9141 interface
 - ISO9141 serial interface (K-Line)
- CAN transceiver

The CAN bus transceiver allows the connection of the microcontroller, with CAN controller unit, to a high speed CAN bus with transmission rates up to 1Mbit/s for exchange of data with other ECUs.

2 Block diagram

Figure 1. Block diagram

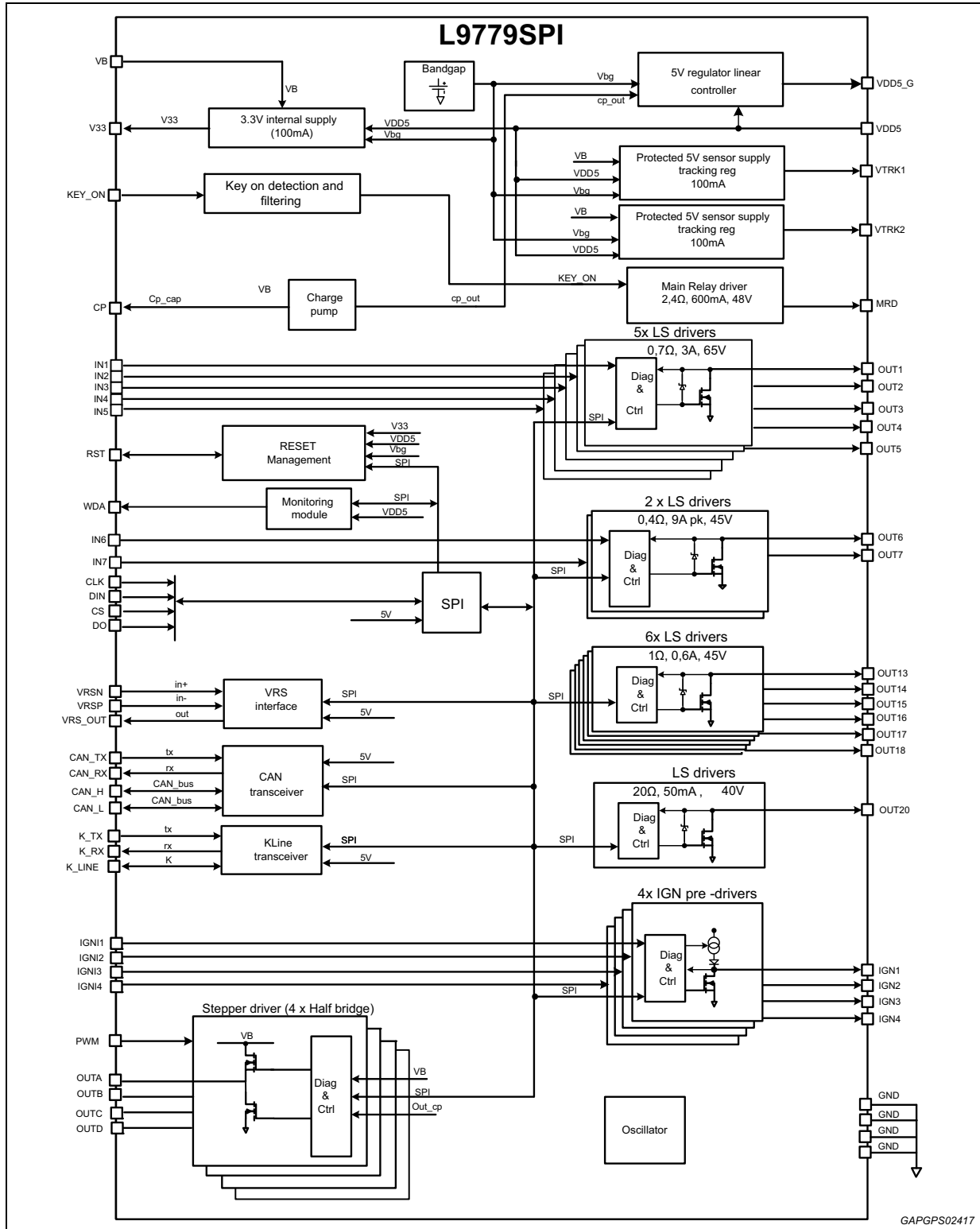

3 Pins description

Figure 2. Pins connection diagram (top view)

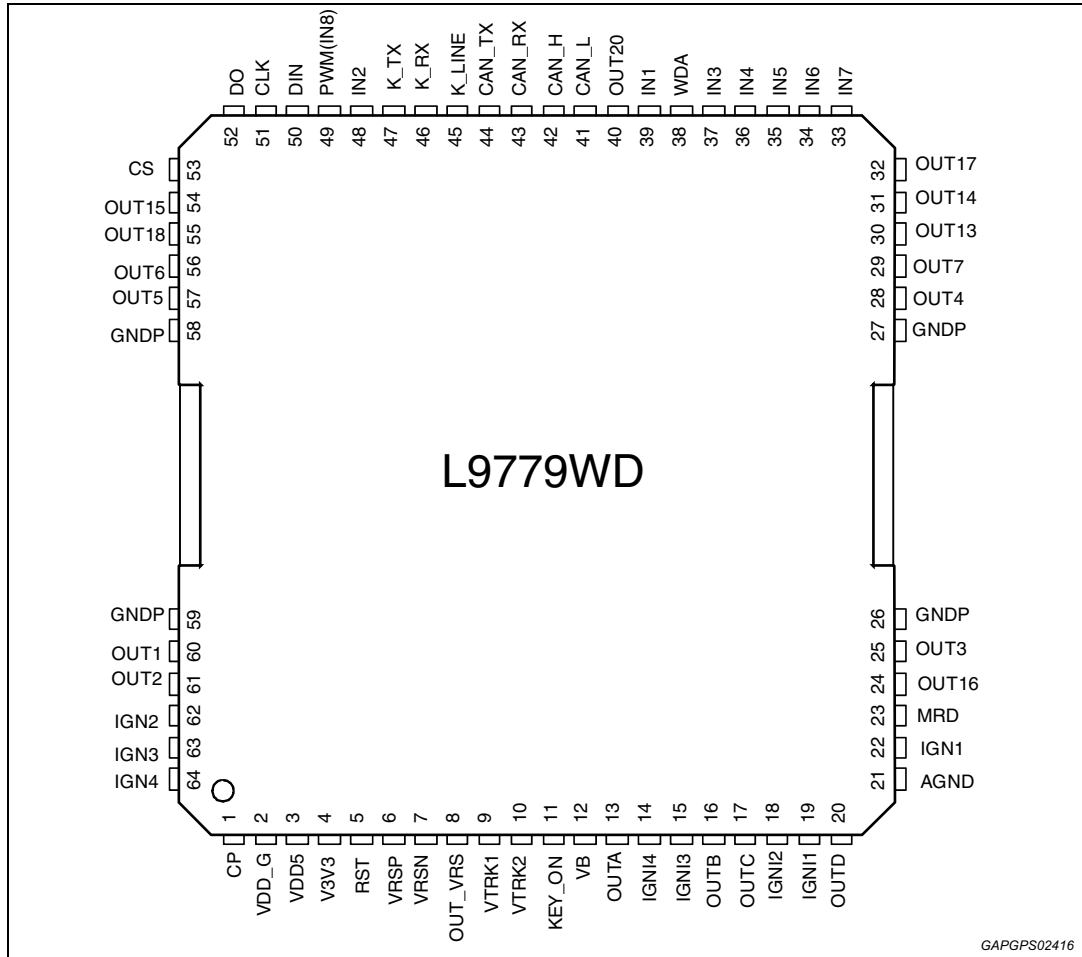

Table 2. Pins description

Pin#	Name	Function	Type	Polarization/note
Supply block				
12	VB	Battery supply	Power supply polarization	-
3	VDD5	5 V output voltage regulator	Power logic output supply	-
2	VDD_G	5 V regulator ext MOS gate	Analog output	-
11	KEY_ON	Key signal	Analog Input protected with 20 kΩ resistor	PD 100 kΩ

Table 2. Pins description (continued)

Pin#	Name	Function	Type	Polarization/note
4	V3V3	3.3 V output voltage regulator	Power logic output supply	-
1	CP	Charge Pump	Analog Input	-
9	VTRK1	Sensor1 tracking supply 5V	Sensor supply output	-
10	VTRK2	Sensor1 tracking supply 5 V	Sensor supply output	-
5	RST	Reset output for μ P	DGT output	Open drain $10k\Omega > PU > 1k\Omega^{(1)}$
38	WDA	WDA Interrupt Signal	Output: open drain DGT input	-
VRS				
7	VRSN	Negative VRS input	Analog Input	1.65 V Internal polarization
6	VRSP	Positive VRS input	Analog Input	1.65 V Internal polarization
8	OUT_VRS	Digital VRS output	DGT Output	Open drain
CAN				
44	CAN_TX	Can transceiver input (from TX μ P)	DGT Input	-
43	CAN_RX	Can transceiver output (to RX μ P)	DGT Output	-
42	CAN_H	Bi-dir protected CAN_H wire	Analog Input/Output	-
41	CAN_L	Bi-dir protected CAN_L wire	Analog Input/Output	-
ISO9141				
47	K_TX	ISO9141 logical input	DGT Input	$I_{Pu} = 20 \mu A$
45	K_LINE	Bi-dir protected K-line wire	Analog Input/Output	Open drain
46	K_RX	ISO9141 logical output	DGT Output	Open drain
Low side drivers				
60	OUT1	Output low-side 1 for R , L Load(Injector)	Power output	Open drain
61	OUT2	Output low-side 2 for R , L Load(Injector)	Power output	Open drain
25	OUT3	Output low-side 3 for R , L Load(Injector)	Power output	Open drain

Table 2. Pins description (continued)

Pin#	Name	Function	Type	Polarization/note
28	OUT4	Output low-side 4 for R, L Load(Injector)	Power output	Open drain
26	PGND3	Power GND	PGND1	-
27	PGND4	Power GND	PGND2	-
57	OUT5	Output low-side 5 for R , L Load(High current)	Power output	Open drain
56	OUT6	Output low-side 6 for R , L Load(Heater)	Power output	Open drain
29	OUT7	Output low-side 7 for R , L Load(Heater)	Power output	Open drain
30	OUT13	Output low-side 13 for Relay	Power output	Open drain
31	OUT14	Output low-side 14 for relay	Power output	Open drain
54	OUT15	output low-side 15 for relay	Power output	Open drain
24	OUT16	Output low-side 16 for relay	Power output	Open drain
32	OUT17	Output low-side 17 for relay	Power output	Open drain
55	OUT18	Output low-side 18 for relay	Power output	Open drain
58	PGND3	Power GND	PGND3	-
59	PGND4	Power GND	PGND4	-
IGBT pre-driver				
22	IGN1	Output ignition driver 1	Power output	-
62	IGN2	Output ignition driver 2	Power output	-
63	IGN3	Output ignition driver 3	Power output	-
64	IGN4	Output ignition driver 4	Power output	-
Main relay driver				
23	MRD	Main relay driver	Power output	Open drain
Low current drivers (50 mA)				
40	OUT20	Output low-side 20	Power output	Open drain
Parallel input				
39	IN1	Parallel input for OUT1	DGT Input	-
48	IN2	Parallel input for OUT2	DGT Input	-
37	IN3	Parallel input for OUT3	DGT Input	-
36	IN4	Parallel input for OUT4	DGT Input	-
35	IN5	Parallel input for OUT5	DGT Input	-
34	IN6	Parallel input for OUT6	DGT Input	-

Table 2. Pins description (continued)

Pin#	Name	Function	Type	Polarization/note
33	IN7	Parallel input for OUT7	DGT Input	-
49	PWM (IN8)	PWM input for stepper motor driving	DGT Input	-
19	IGNI1	Parallel input for IGN1	DGT Input	-
18	IGNI2	Parallel input for IGN2	DGT Input	-
15	IGNI3	Parallel input for IGN3	DGT Input	-
14	IGNI4	Parallel input for IGN4	DGT Input	-
SPI interface				
51	SCK	SPI clock input	DGT Input	-
53	CS	SPI chip select	DGT Input	-
50	DIN	SPI data input	DGT Input	-
52	DO	SPI data output	DGT Output	-
Stepper motor driver				
13	OUTA	Stepper	Power output	-
16	OUTB	Stepper	Power output	-
17	OUTC	Stepper	Power output	-
20	OUTD	Stepper	Power output	-
21	GND	Stepper GND	GND	-

1. External components required.

Note: OUT11 and OUT12 are not valid.

4 Application schematic

Figure 3. Application schematic

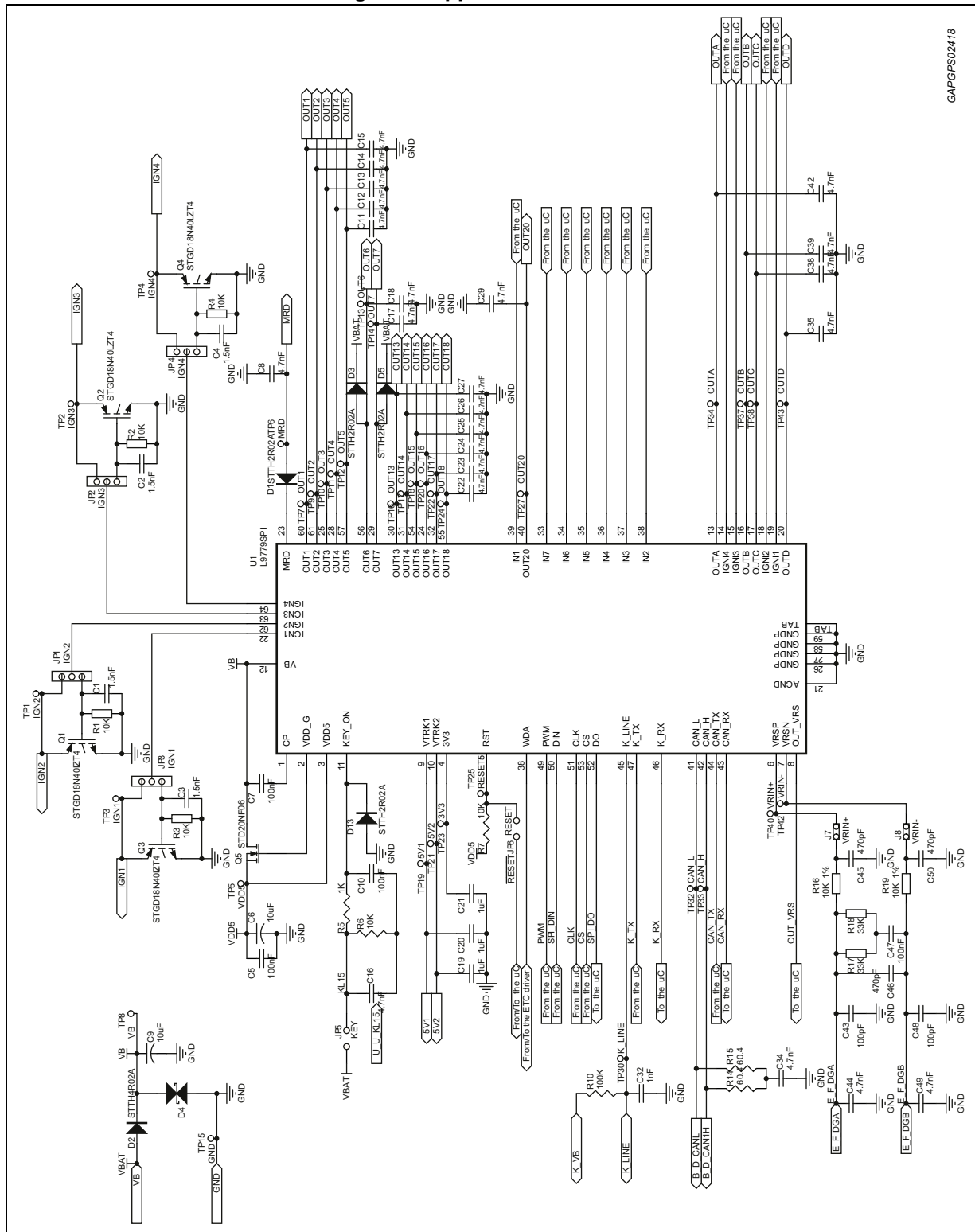

5 Absolute maximum ratings

Warning: Maximum ratings are absolute ratings: exceeding any of these values may cause permanent damage to the integrated circuit

Table 3. Absolute maximum ratings

Pin	Parameter	Condition	Value	Unit
VB	DC supply battery power voltage (Vb)	Also without external components	-0.3 to +40	V
V3V3	DC logic supply voltage	-	-0.3 to VDD5, when V3V3 = VDD5 = 19 V max	V
VTRK1,2	DC sensors supply voltage	-	-2 to +40	V
VDD_G	-	-	-0.3 to VDD5, when VDDG = VDD5 = 19 V max	V
VDD5	Voltage pin	-	-0.3 to 19	V
CP	-	-	-0.3 to 40 Max ABS = +40 V when VB = 40 V	V
KEY_ON	-	Protected with external component (R = 1 k Ω plus a diode, refer to Figure 4) for negative pulse (isopulse 1)	-1.2 to +40	V
RST	-	-	-0.3 to +19	V
VRSP	-	Max current to be limited with external resistors (see Section 6.14.3: Application circuits on page 93)	-20 to +20	mA
VRSM	-	Max current to be limited with external resistors (see Section 6.14.3: Application circuits on page 93)	-20 to +20	mA
MRD	-	-	-0.3 to +40	V
OUT1-5	Low-side output	-	-1 to +53	V
OUT6-7	Low-side output	-	-1 to +40	V
OUT13-18	Low-side output	-	-1 to +40	V
OUT20	Low-side output	-	-1 to +40	
IGNx	-	-	-1 to 19	V

Table 3. Absolute maximum ratings (continued)

Pin	Parameter	Condition	Value	Unit
OUTA, OUTB, OUTC, OUTD	Half bridge output	With external diode vs ground for negative voltage	-1.0 to VB (-2.0 dynamically for a short time)	V
DO, CAN_RX, K_RX, OUT_VRS	-	-	-0.3 to VDD_IO, when DO = VDD_IO = 19 V max	V
CS, CLK, DIN, IN1, IN2, IN3, IN4, IN5, IN6, IN7, PWM, IGN1, IGN2, IGN3, IGN4	-	-	-0.3 to +19	V
CAN_TX	-	-	-0.3 to +19	V
CAN_H, CAN_L	-	-	-18 to 40	V
K_TX	-	-	-0.3 to +19	V
K_LINE	-	-	-18 to 40	V

5.1 ESD protection

Table 4. ESD protection

Item	Condition	Min	Max	Unit
All pins	Electro static discharge voltage “Charged-device-model – CDM” all pin ⁽¹⁾	-500	+500	V
All pins	Electro static discharge voltage “Charged-device-model – CDM” corner pin (1,20,21,32,33,52,53,64)	-750	+750	V
All pins	ESD voltage HBM respect to GND	-2	+2	KV
Pins to connector ⁽²⁾	ESD voltage HBM respect to GND	-4	+4	KV

1. Except OUTA, B, C, D ±250 V.

2. Pins are LSa, LSb, LSc, LSd, IGNx, VTRK1-2, CAN_H, CAN_L, K_LINE, OUTA, B, C, D.

Test circuit according to HBM (EIA/JESD22-A114-B) and CDM (EIA/JESD22-C101-C).

5.2 Latch-up test

According to JEDEC 78 class 2 level A.

5.3 Temperature ranges and thermal data

Table 5. Temperature ranges and thermal data

Symbol	Parameter	Min	Max	Unit
T_{amb}	Operating temperature	-40	125	°C
T_j	Continuative operative junction temperature	-40	150	°C
T_{stg}	Storage temperature	-40	150	°C
$R_{thj-case}$	Thermal resistance junction-to-case	-	1	°C/W
$R_{thj-amb}$	Thermal resistance junction-to-ambient ⁽¹⁾	-	16	°C/W
T_s	Lead temperature during soldering (for a time = 10 s max)	-	260	°C

1. With 2S2P+vias PCB.

5.4 Operating range

Table 6. Operating range

Pins symbol	Battery voltage range	Junction temperature condition	Note
VB	$4.15\text{ V} < V_b < 6\text{ V}$	$-40 < T_j < 40$	Low battery
	$6\text{ V} < V_b = 18\text{ V}$	$-40 < T_j < 150$	Normal battery
	$18\text{ V} < V_b = 28\text{ V}$	$-40 < T_j < 40$	High battery
	$28 < V_b = 40\text{ V}$, $t_{rise} = 10\text{ms}$, $T_{pulse} = 400\text{ ms}$.	$-40 < T_j < 40$	Load dump

5.4.1 Low battery

All the functions are guaranteed with degraded parameters. The voltage regulators follow VB in RDSon mode with drop-out depending on load current. V3V3 regulator works as expected assuming $V_{DD5} > 4\text{ V}$.

5.4.2 Normal battery

All the functions and the parameters are guaranteed by testing coverage.

5.4.3 High battery

All the functions are guaranteed with degraded parameters.

5.4.4 Load dump

The device is switched-off if load dump exceeds battery overvoltage threshold for a time longer than filter time.

6 Functional description

6.1 Ignition switch, main relay, battery pin

The system has an ignition switch pin KEY_ON and a pin VB for battery behind the main relay connected at pin MRD.

L9779WD-SPI can also support the configuration where it is permanently supplied by VB; in this case the MRD output can be used to connect the loads to VB.

At pin KEY_ON there is an external diode for reverse battery protection. An internal Pull-down resistor is provided on the KEY_ON pin. The external components to be connected to KEY pin are shown in the below schematic.

Internal functions and regulators are supplied by VB; only some basic functions required for startup are supplied from KEY_ON as described below. Reverse protection for pin VB is done by the main relay. Transient negative voltage at VB may be limited by an external diode if necessary. There is no integrated reverse protection at pin VB.

The pin connected to the battery line can bear the ISO 7637/1 noise pulses without any damage. The VB voltage must be externally limited to +40 V and -0.3 V (with external components as in [Figure 4](#)). It is suggested the use of a transil.

Figure 4. Configuration supplied by VB

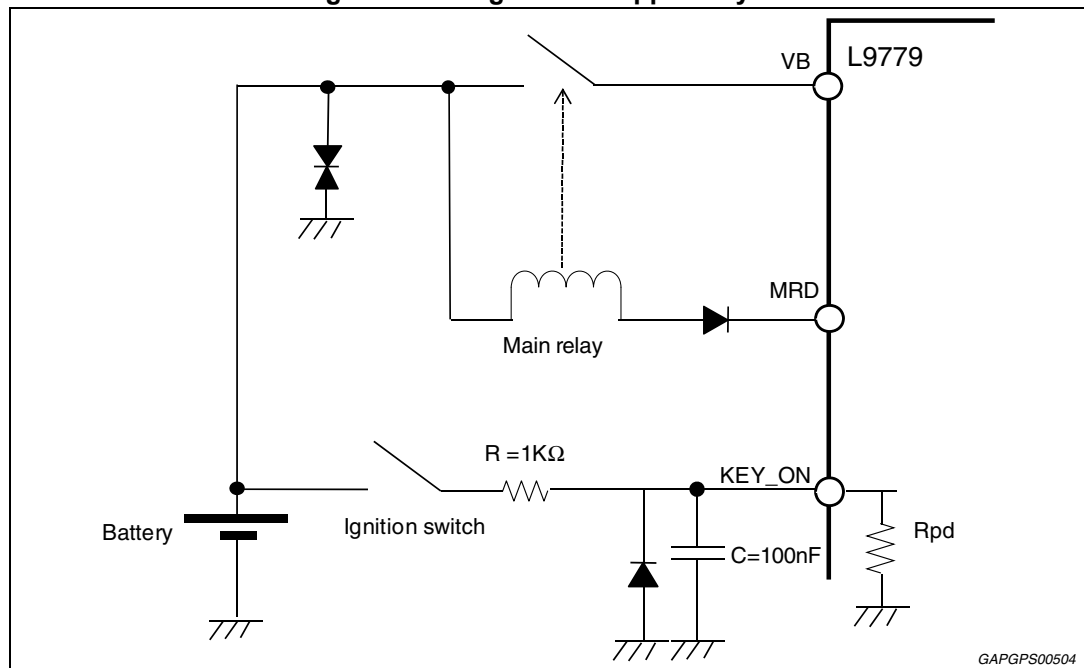

1. The external components connected to KEY_ON pin are mandatory in order to protect the device from ISO 7637 pulses.

6.2 Power-up/down management unit

Figure 5. Power-up/down management unit

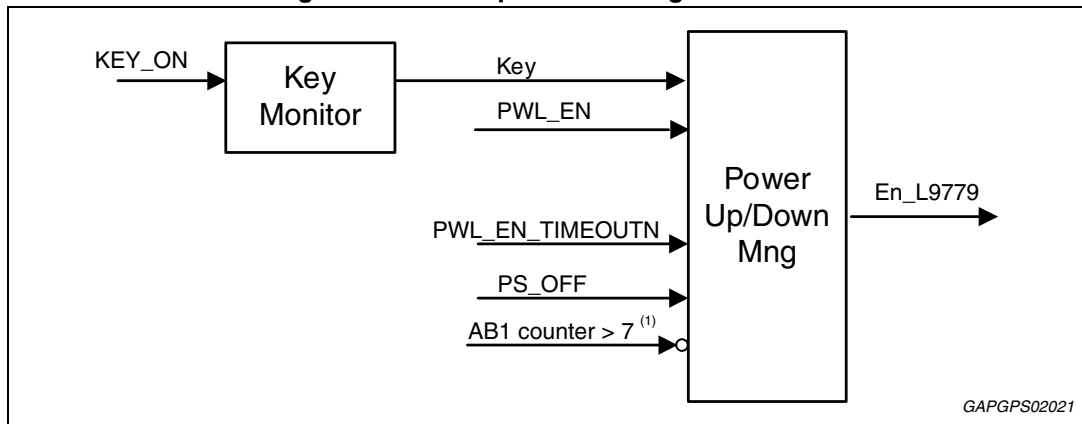

1. AB1 counter function defined at WDA [Section 6.15.1](#).

6.2.1 Power-up sequence

Figure 6. Non-permanent supply power-up sequence

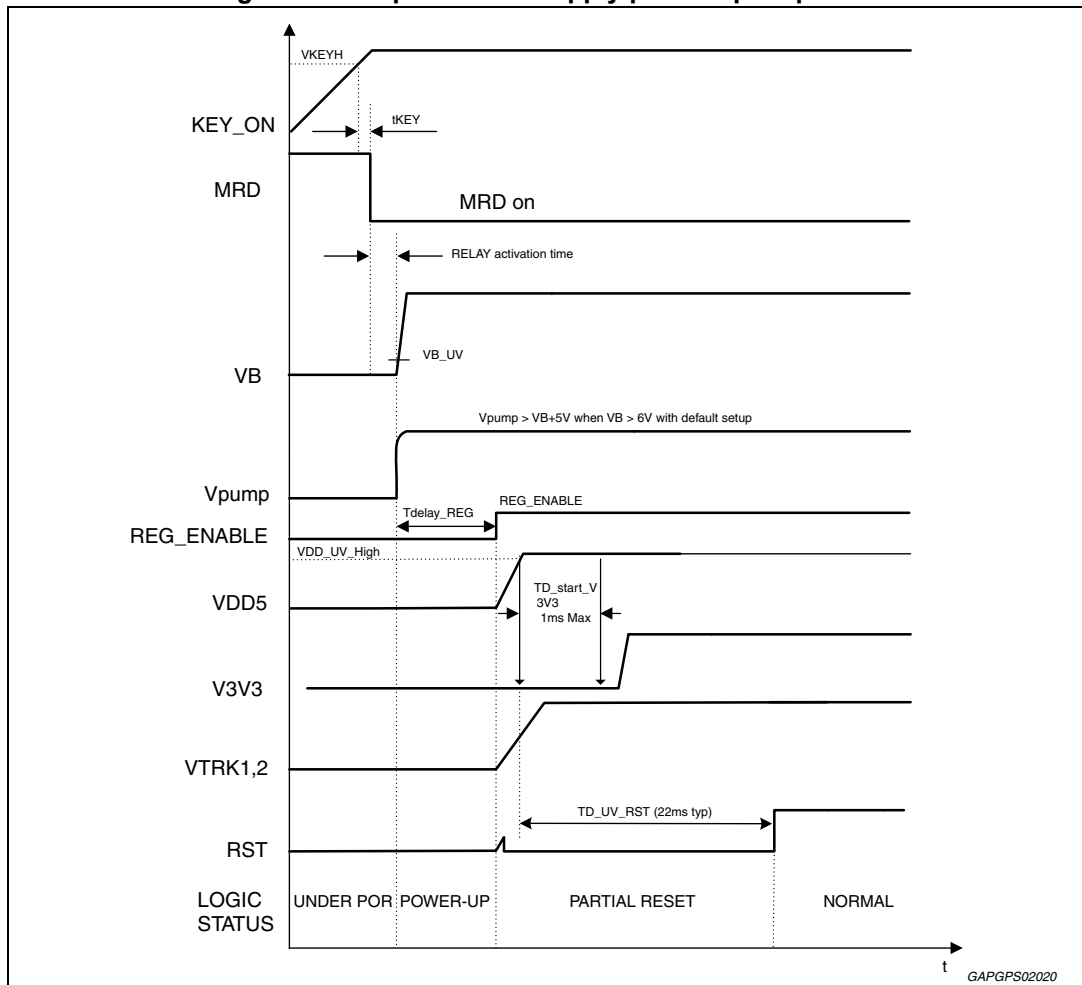

When the KEY_ON reaches a sufficient high voltage VKEYH, after a minimum deglitch filter time T_KEY the system is switched on. First of all the main relay driver is switched on, so the main relay connects VB pin to battery.

Control current into pin KEY_ON is sufficient for basic functions such as filtering time, control of the main relay output stage, internal oscillator and internal bias currents.

When the voltage at VB exceeds the under voltage-detection threshold for VB (VB_UV_H) the internal biasing circuits are activated.

VDD5 regulator is activated Tdelay_REG seconds later. After VDD5 exceeds the VDD_UV threshold and with typ. 1.0 ms delay, the V3V3 is activated also. The sensor supplies VTRK1, 2 are turned on together with VDD5.

Figure 7. Permanent supply power-up sequence

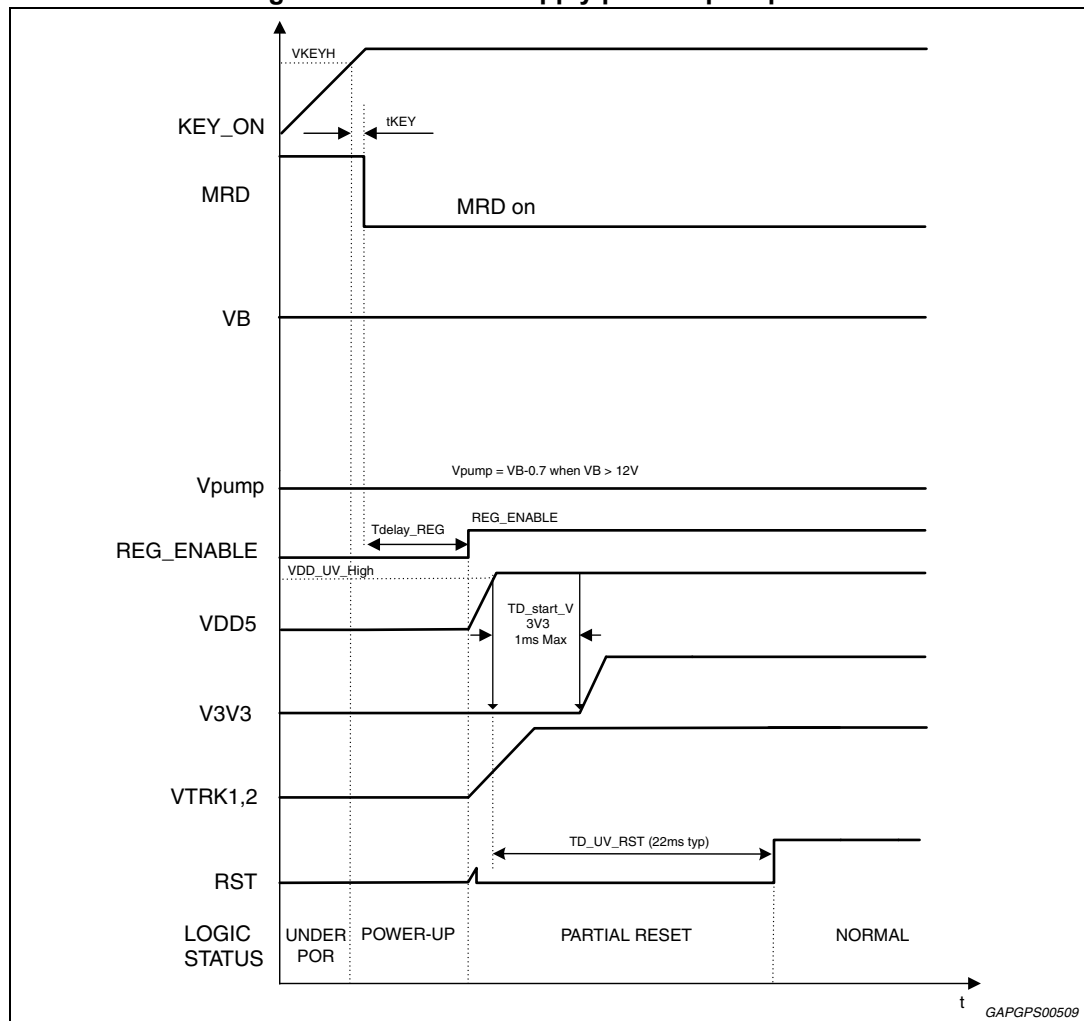

In the case when VB is always connected, when the KEY_ON voltage exceeds VKEYH the internal biasing circuits are activated.

VDD5 regulator is activated Tdelay_REG seconds after the tKEY filter time has expired.

VDD5 regulator is activated Tdelay_REG seconds later. After VDD5 exceeds the VDD_UV threshold and with typ. 1.0 ms delay, the V3V3 has activated also. The sensor supplies VTRK1, 2 are turned on together with VDD5.

6.2.2 Power-down sequence

The system is switched off according to the status of KEY_ON, VB and power latch mode bit PWL_EN_N set by the μ C, according to:

$$\text{En_L9779} = [(\text{!PWL_EN_N AND PWL_EN_TIMEOUTN}) \text{ OR KEY_ON}] \text{ AND VB_UVN}.$$

The KEY_ON is the status of KEY_ON pin after deglitch filter time.

En_L9779 represents the enable signals used by different blocks.

The system will be switched off after a minimum deglitch filter time if the voltage at pin KEY_ON is below VKEYL and if power latch mode is not active i.e. PWL_EN_N=1.

Otherwise, if the power latch mode is active PWL_EN_N=0, nothing happens until the power latch mode has finished by the μ C writing PWL_EN_N=1.

However L9779WD-SPI will wait for a maximum time-out time PWL_TIMEOUT for PWL_EN_N de-assertion after which the system will be forced to switch off.

PWL_TIMEOUT can be enabled and configured by 3 bit PWL_TIMEOUT_CONF.

For TNL description see Smart reset circuit description.

The status of KEY_ON can be read through the bit KEY_ON_STATUS. After tKEY filter time the status of KEY_ON can be read through the bit KEY_ON_FLT also.

All the supply outputs shall be switched-off simultaneously. If the supplied devices have particular sequencing requirements, external diodes or clamping devices will be used.

During power down, whether the regulators are switched off at the same time as the main relay output or not is decided via the <PSOFF> bit.

- <PSOFF>='0' (default): simultaneous switching-off the regulators with the main-relay driver MRD
- <PSOFF>='1': regulators remain active when the main relay driver MRD will be switched off

With this function it is possible to detect a stuck main relay. If conditions to switch off are satisfied when <PSOFF>='1', the MRD is switched off while the voltage regulators continue to operate as long as no under voltage is detected at VB. The RST pin is not asserted till VDD_UV. The μ C measures the time passed since shutdown. If a certain time is exceeded, then a stuck main relay is detected and this fault is stored in the μ C (not in the L9779WD-SPI). After this the μ C turns off the voltage regulators by setting the bit <PSOFF> to '0' (reset state). With a stuck main relay the voltage at pin VB remains present at battery level with a current consumption of I_{Leak} .

Secure Engine Off function is that the engine can be directly switched off by the key-switch via a hardware path and without the help or interference of software or μ C.

Whenever the KEY_ON signal goes low the output stages mentioned in the following pages are disabled, no matter what other conditions (like e.g. "power-latch") are.

In no power latch/no SEO mode the key-switch has direct shut-off access to the injector stages (OUT1-4) and to the starter relay drivers (OUT13 and OUT14).

An additional feature for the starter delay drivers is that the starters are only shut-off after the time delay THOLD if the SEO condition is still active.

The ignition stages are not affected by the SEO signal. This is different from the WDA signal which additionally switches off the ignition stages.

To avoid misunderstandings one must be aware that the SEO function has nothing to do with the WDA function and is not a part of the WDA module. The SEO function is related to the key switch, not to the WDA function. The SEO function adds an additional safety procedure for switching off.

Other functions than the injector stages and the starter relay drivers are not affected or influenced by the SEO signal.

With the falling edge of KEY_ON a timer is started which disables the mentioned power stages after 200 ms to 250 ms (typ. 225 ms). The timer is clocked by an internal oscillator. The timer does not depend on any μC clock or function. The μC still has control on switching on/off drivers during SEO time. This function is configured by CONFIG_REG6 register.

Figure 8. Power-down sequence without power latch mode

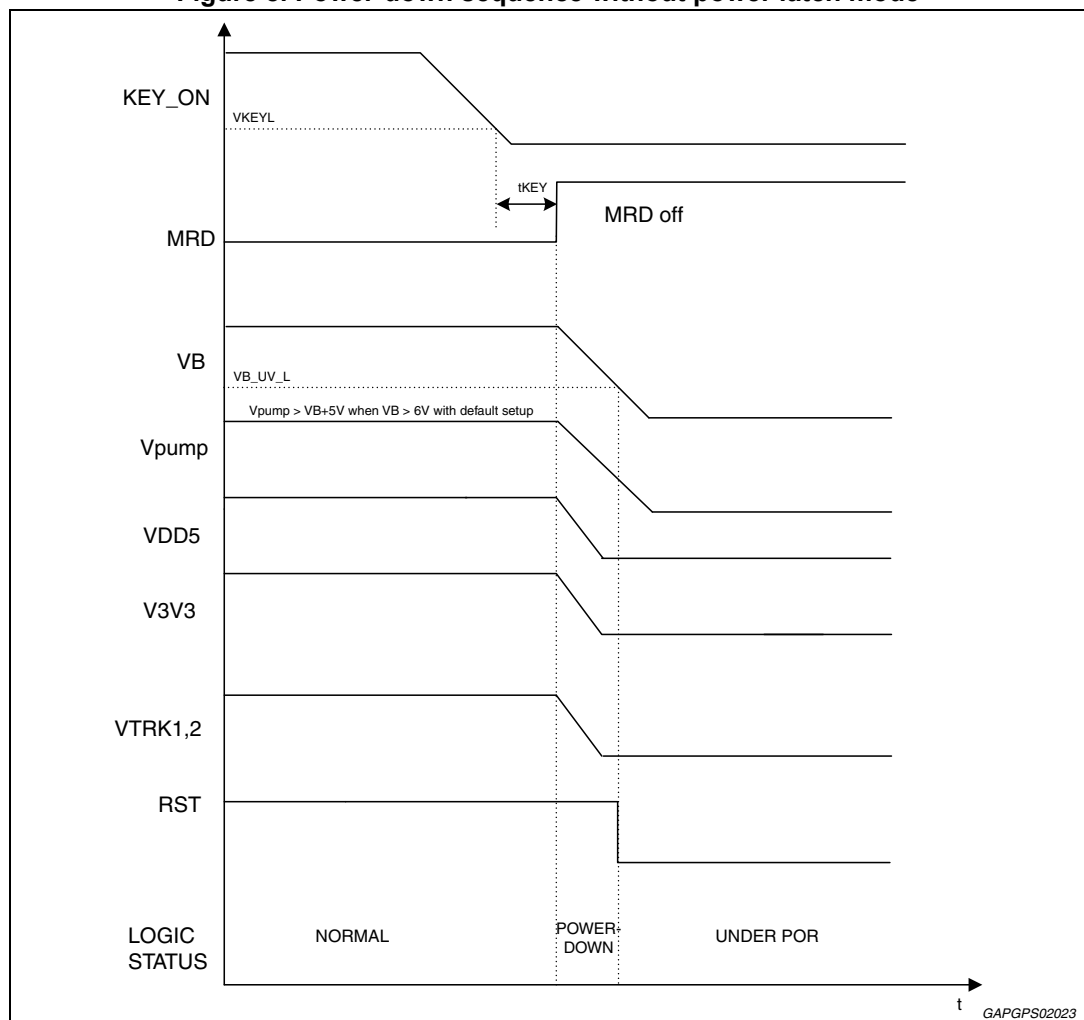

Figure 9. Power-down sequence without power latch mode and PSOFF = 1

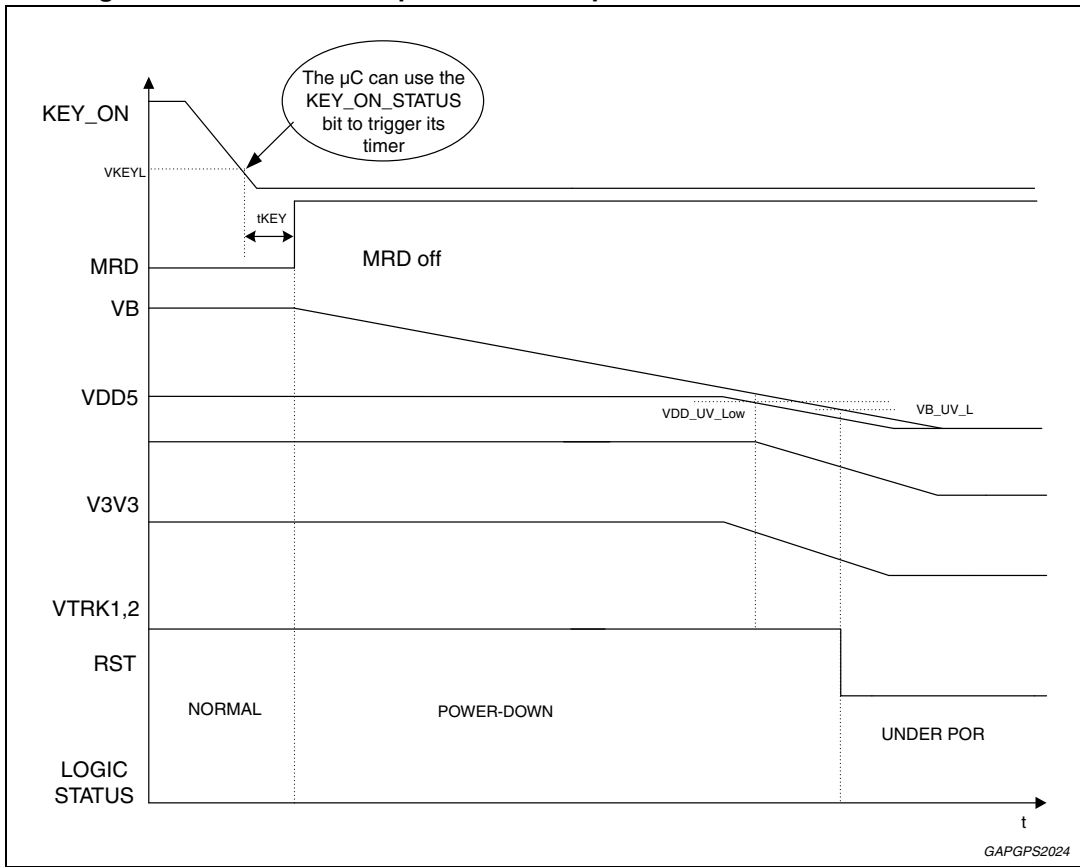

Figure 10. Power-down sequence with power latch mode

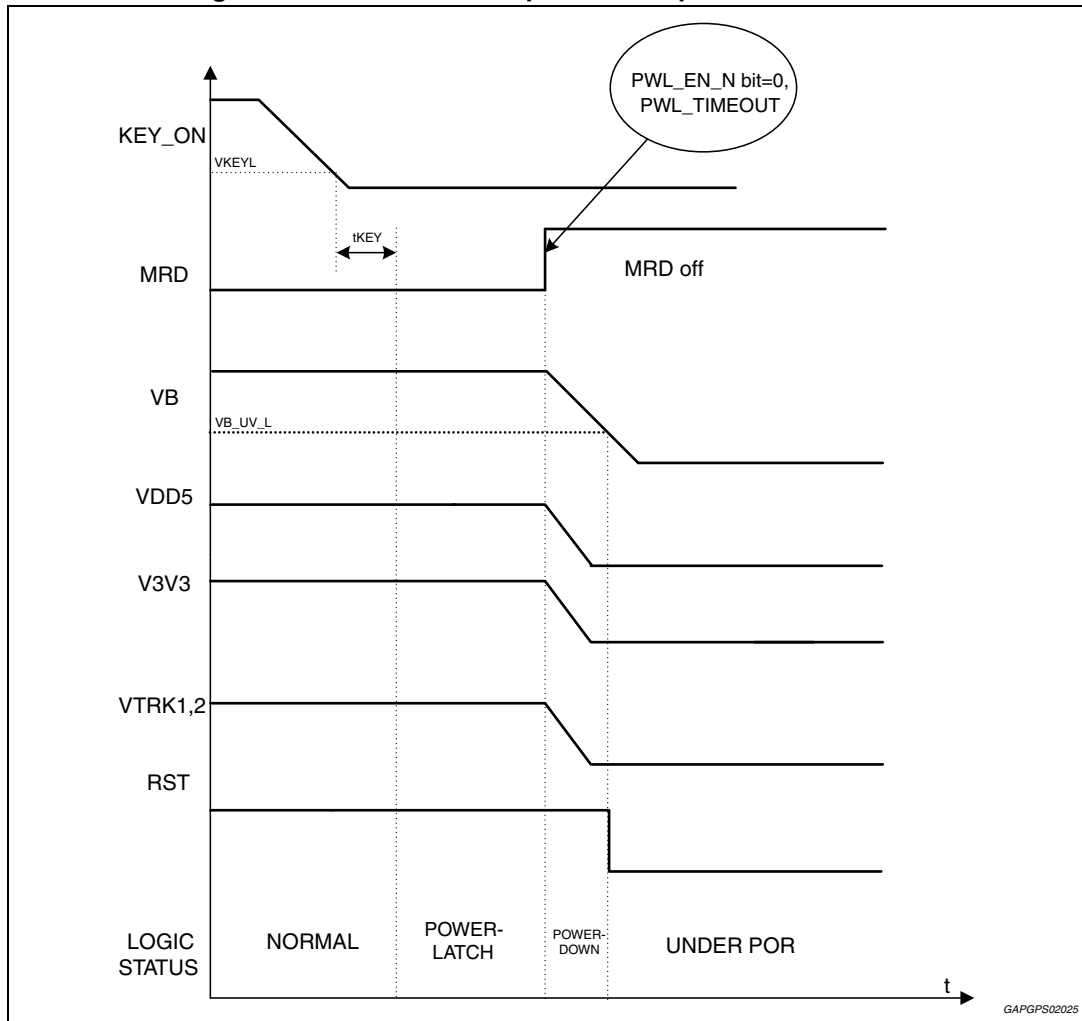

Figure 11. Power-down sequence with power latch mode and KEY_ON toggle

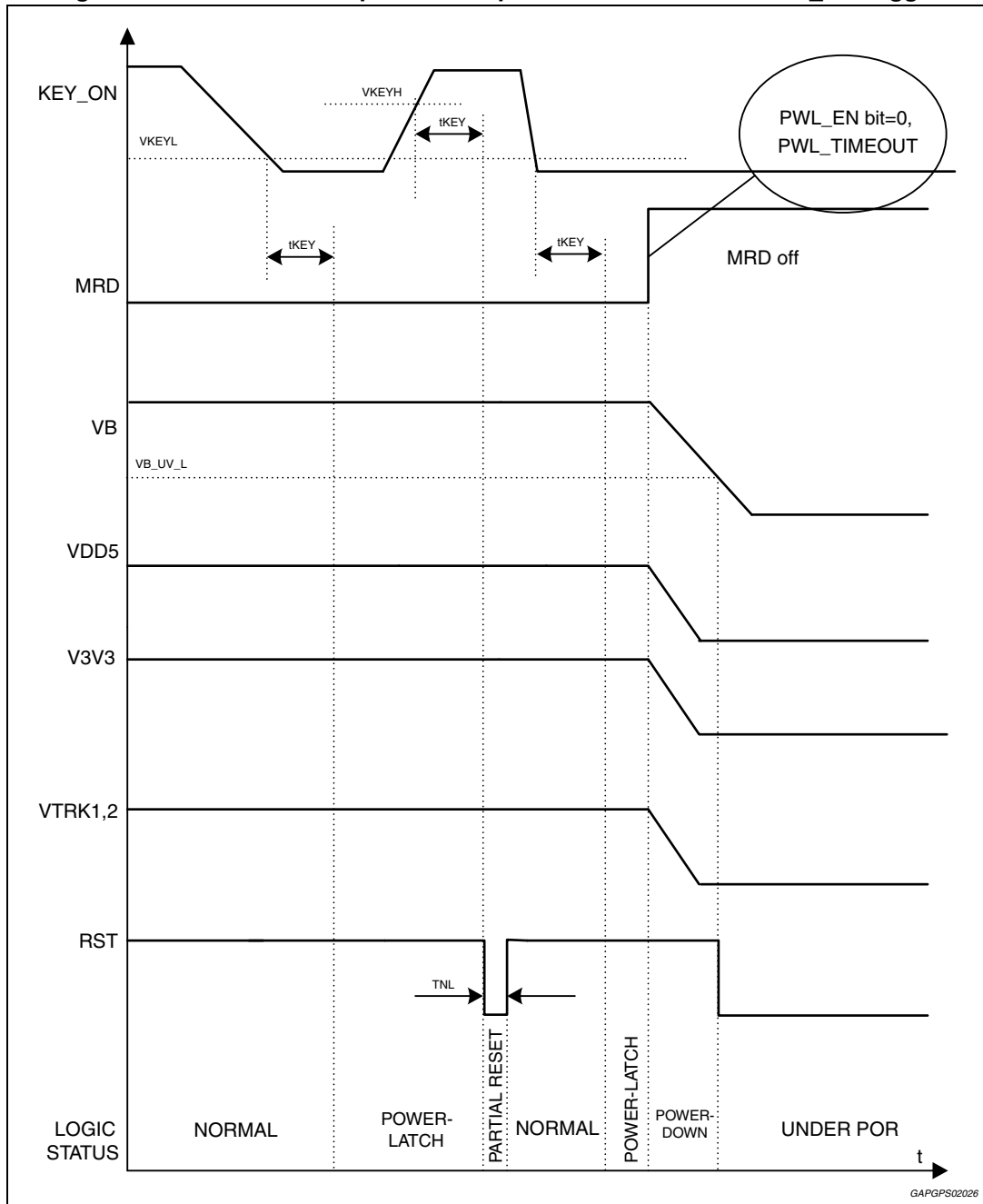
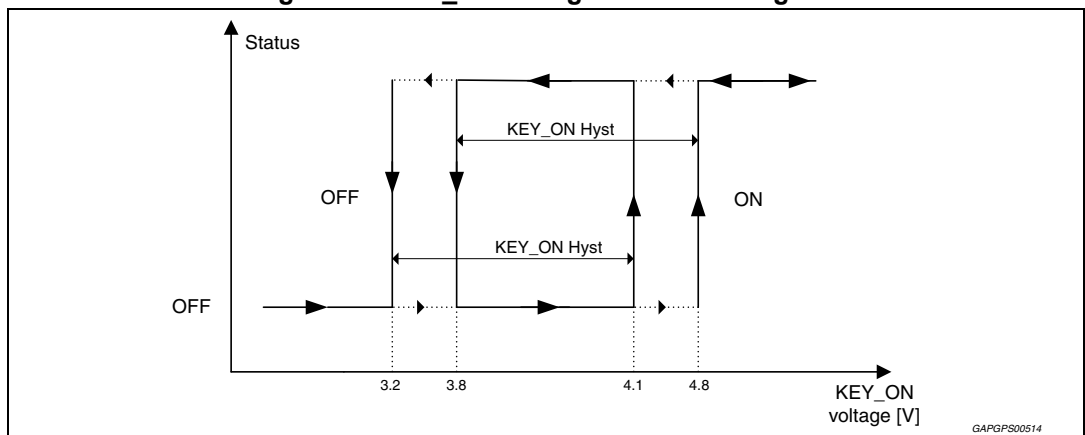

Table 7. KEY_ON pin electrical characteristics

Pin	Symbol	Parameter	Test condition	Min	Typ	Max	Unit
KEY_ON	VKEYL	Input threshold low voltage	VB = 0 to 19 V	3.2	3.5	3.8	V
	VKEYH	Input threshold high voltage		4.15	4.5	4.8	V
	VKEYHYS	Input voltage hysteresis		0.5	1	1.5	V
	I_KEY	Input current	VB = 0 to 19 V KEY_ON = 5 V	-	-	550	µA
	t _{KEY}	Filter time for switching on/off	VB = 0 to 19 V	7.5	16	24	ms
	Rpd	Internal pull down resistor - NOT tested - Guarantee by design	KEY_ON = 5 V	150	-	400	kΩ

Figure 12. KEY_ON voltage vs. status diagram



6.3 Smart reset circuit

Figure 13. Smart reset circuit

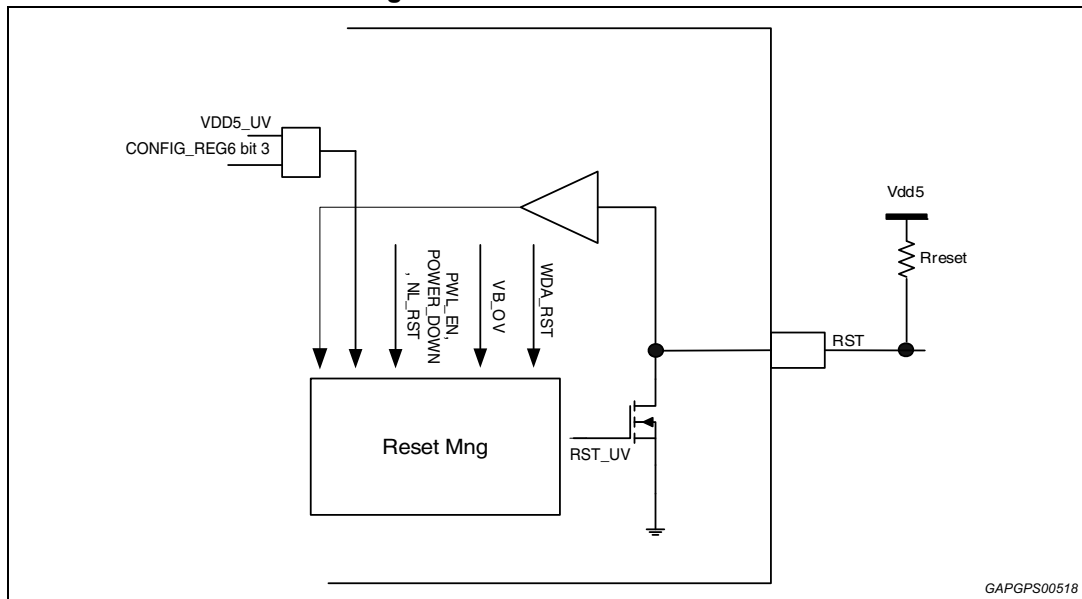

GAPGPS00518

6.3.1 Smart reset circuit functionality description

The RST pin is an input/output active when low. As output pin the Smart Reset circuit takes into account several events of the device in order to generate the proper reset signal at RST pin for the microcontroller and for a portion of the internal logic as well. As input pin RST when driven low by external source for more than $Trst_ft$, it is used to reset the same portion of logic of the device.

The sources of reset are:

- VDD5 under voltage it can be disabled by SPI CONFIG_REG6 bit3 = high, default is low i.e. enabled
- Power down
- Power latch, KEY_ON
- VB overvoltage
- WDA_RST, query and answer watchdog reset

Smart reset circuit generates RST signal monitoring the VDD5 according to the graph shown below: when VDD5 falls below VDD_UV_LOW threshold for a time longer than $TfUV_reset$ Smart Reset circuit asserts a RST signal (driven low) and the flag CRK_RST is latched and resets every Read Diag operation. When VDD5 recovers to a voltage greater than VDD_UV_HIGH RST pin is deasserted after Td_UV_rst . The RST pin is also asserted at the first power-on phase when the KEY_ON pin goes from low to high, as a consequence of the VDD5 absence.

Smart reset circuit generates an RST signal at power down independently of filtering time and VDD5 voltage level. During power latch mode if NL_RST bit is set and KEY_ON signal goes low to high again (before microcontroller was able to write $PWL_EN_N=0$), RST_PIN is asserted for time TNL.

Smart reset circuit monitors VB over voltage and generates RST signal if the over voltage lasts more than tVBOV2. When over voltage lasts more than tVBOV1 and less than tVBOV2, RST is not asserted, but all drivers are switched off without losing any configuration. In both cases the flag VB_OV is latched and resets every Read Diag operation.

When RST is asserted to reset the μ C, also all logic will be reset except logic involved in reset management, power up management, and power down management units. As a consequence all flags are cleared except those set by the smart reset unit, all drivers are disabled except the low battery drivers, all configuration registers are cleared and OUT_DIS bit goes to 1. A more detailed description of the module under reset can be found in the next table. The table summaries also relations with other conditions that switch off drivers and regulator.

Table 8. Internal reset

Event	RST pin driven low	Logic under reset	Logic not reset	Power-up/down manager output	Information FLAG
Power down	Yes	Internal registers Interfaces drivers LB interfaces drivers LB internal registers CAN & K-LINE & VRS	Smart reset function Power-up/down manager	MRD=OFF VDD5=OFF V3V3=OFF VTRACK1,2=OFF	N/A
Power latch +KEY_ON rising edge	Yes For TNL	Internal registers Interfaces drivers LB interfaces drivers LB internal registers CAN & K-LINE & VRS	Smart reset function Power-up/down manager	MRD=ON VDD5=ON V3V3=ON VTRACK1,2=ON	TNL_RST
VDD5 under voltage $t < THOLD$	Yes	Internal registers Interfaces drivers CAN & K-LINE & VRS	LB interfaces drivers LB internal registers Smart reset function Power-up/down manager	MRD=ON VDD5=ON V3V3=ON VTRACK1,2=ON	CRK_RST
VDD5 under voltage $t > THOLD$	Yes	Internal registers Interfaces drivers LB interfaces drivers LB internal registers CAN & K-LINE & VRS	Smart reset function Power-up/down manager	MRD=ON VDD5=ON V3V3=ON VTRACK1,2=ON	VDD5UV_RST
VDD5 over voltage	No	Interfaces drivers	Internal registers LB interfaces drivers LB internal registers CAN & K-LINE & VRS Smart reset function Power-up/down manager	MRD=ON VDD5=ON V3V3=ON VTRACK1,2=ON	VDD5_OV

Table 8. Internal reset (continued)

Event	RST pin driven low	Logic under reset	Logic not reset	Power-up/down manager output	Information FLAG
VB over voltage $t_{TBOV1} < t < t_{TBOV2}$	No	Interfaces drivers LB interfaces drivers	Internal registers LB internal registers CAN & K-LINE & VRS Smart reset function Power-up/down manager	MRD=ON VDD5=ON V3V3=ON VTRACK1,2=ON	OV_RST
VB over voltage $t > t_{TBOV2}$	Yes	Internal registers Interfaces drivers LB interfaces drivers LB internal registers CAN & K-LINE & VRS	Smart reset function Power-up/down manager	MRD=ON VDD5=OFF V3V3=OFF VTRACK1,2=OFF	OV_RST
RST driven low externally $t < THOLD$	Yes	Internal registers Interfaces drivers CAN & K-LINE & VRS	LB interfaces drivers LB internal registers Smart reset function Power-up/down manager	Keep state	N/A
RST driven low externally $t > THOLD$	Yes	Internal registers Interfaces drivers LB interfaces drivers LB internal registers CAN & K-LINE & VRS	Smart reset function Power-up/down manager	Keep state	N/A
Software reset sent by the μ C through SPI	No	Internal registers Interfaces drivers LB interfaces drivers LB internal registers CAN & K-LINE & VRS	Smart reset function Power-up/down manager	MRD=ON VDD5=ON V3V3=ON VTRACK1,2=ON	N/A

Legend:

Internal registers = configuration registers
 Interfaces driver = control registers (OUT_DIS), LS/HS drivers, ext-MOS, IGBT
 LB internal registers = include dedicated configuration bit for Low battery drivers
 LB interfaces driver = control registers (OUT_DIS) + interface drivers logic for Low battery drivers
 Smart reset logic = include VDD5 undervoltage and some time counter (TNL, D_UV_RST, THOLD)

Power-up/down manager = include the logic for regulator control and monitoring and MRD managing.

CAN & K-LINE & VRS

Table 9. RST pin external components required

Pin	Symbol	Parameter	Value	Note
RST	R _{reset}	Pull_up reset reference	4.7 kΩ ± 5 %	-

Table 10. RST pin electrical characteristics

Pin	Symbol	Parameter	Test condition	Min	Typ	Max	Unit
As output							
RST	VUV_LO	Output low voltage	1 < VDD5 < VDD_UV R _{reset} = 4.7K	-	-	0.4	V
	IUVres_max	Input current	VDD5 = VDD_UV V _{UV_reset} = 0.6 V	1	-	-	mA
	I _{UV_reset}	Input leakage current	V _{UV_reset} > VDD_UV	-	-	1	µA
	TD_UV_RS T	Power-on reset delay	Tested by scan	17	-	30	ms
	TNL	Power latch mode exit delay	Tested by scan	1.4	2	2.6	ms
As input							
RST	RST_L	RST Input low voltage	-	-0.3	-	1.1	V
	RST_H	RST input high voltage	-	2.3	-	VDD+0.3	V
	Trstflt	Reset filter time	Tested by scan	7.5	10	12.5	µs
	R _{RST_PU}	RST pull-up resistor	-	50	-	250	kΩ

Figure 14. RST pin as a function of VDD5 (if CONFIG_REG6 bit3 = Low)

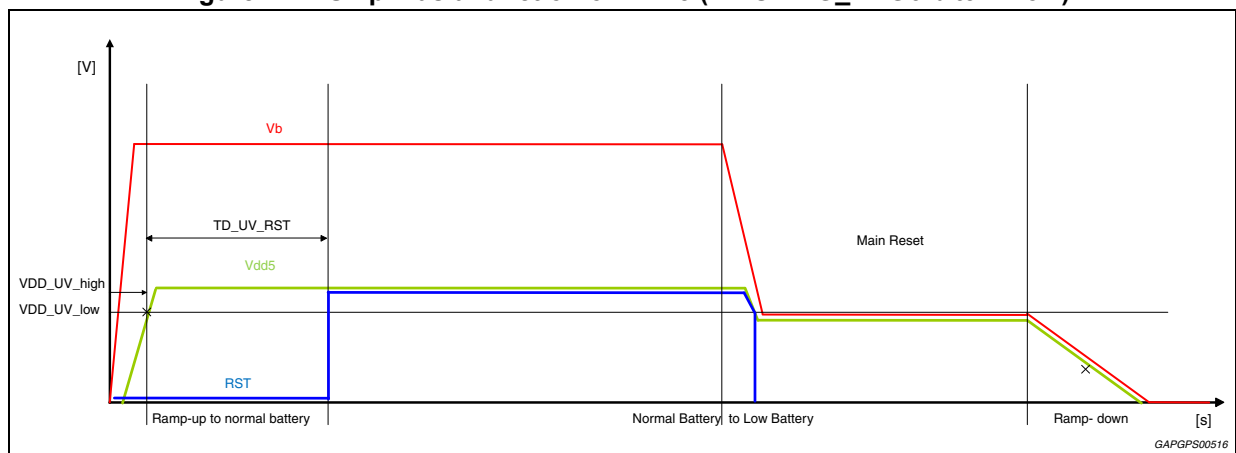

6.4 Thermal shut down

There are 4 temperature sensors:

- OT1 for VTRK1,2
- OT2 for OUT1...10, OUT13...20, OUTA...D, IGN1...4.
- OT3 for MRD
- OT4 for V3V3

When OT1 is higher than θ_{junction} for t_{OT} time VTRK1,2 are switched off if they are in current limitation.

When OT1 is lower than $\theta_{\text{junction}} - \theta_{\text{HYSTERESISV}}$ for t_{OT} time, the device should return to normal operation automatically.

When OT2 is higher than θ_{junction} for t_{OT} time all the OUTx and IGNx are switched off.

When OT2 is lower than $\theta_{\text{junction}} - \theta_{\text{HYSTERESISV}}$ for t_{OT} time, the device should return to normal operation automatically.

When OT3 is higher than θ_{junction} for t_{OT} time the MRD is switched off.

When OT3 is lower than $\theta_{\text{junction}} - \theta_{\text{HYSTERESISV}}$ for t_{OT} time, the device should return to normal operation automatically.

When OT4 is higher than θ_{junction} for t_{OT} time the V3V3 is switched off if it is in current limitation.

When OT4 is lower than $\theta_{\text{junction}} - \theta_{\text{HYSTERESISV}}$ for t_{OT} time, the device should return to normal operation automatically.

Thermal warning information from OT1,OT2,OT3,OT4 is latched and communicated by SPI.

Thermal warning information is reset when it is read.

The latch behavior affects only flags bit, while drivers and supplies use the OTx just after the filter to return to normal operation.

Table 11. Temperature information

Parameter	Value	Unit
θ_{junction}	165 to 185	°C
$\theta_{\text{HYSTERESIS}}$	5-10	°C
t_{OT}	20	µs

6.5 Voltage regulators

Figure 15. Structure regulators diagram

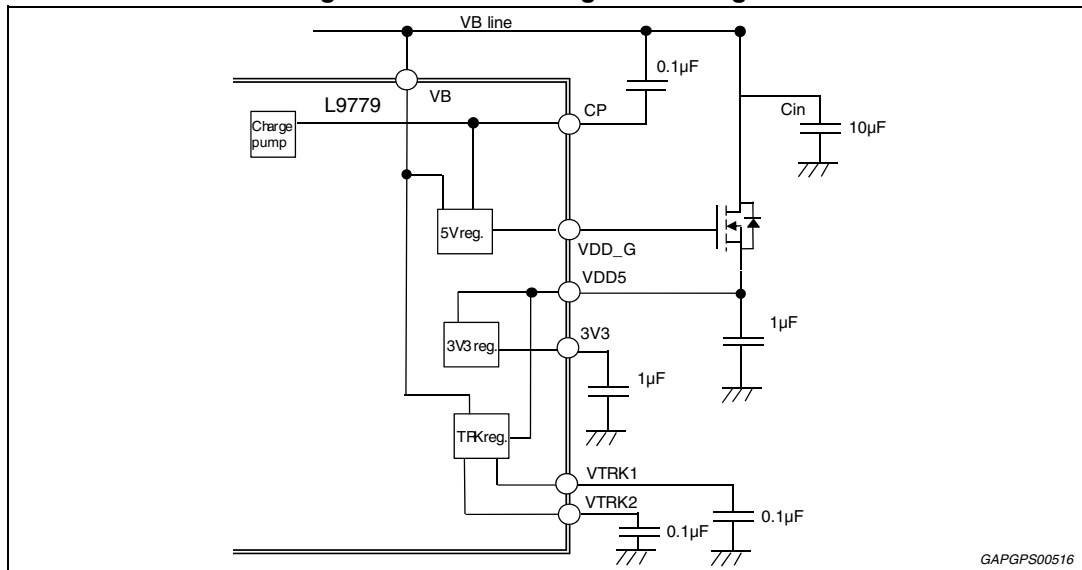

The structure of regulators is showed in the above figure.

The 5 V voltage is obtained through a linear regulator using an external N-Mos. The precision is $\pm 2\%$ with $I_{max} = 400$ mA. The high precision is obtained with a pre-trimmed reference voltage. The under-voltage condition is monitored through the Smart Reset circuit. In addition there is an overvoltage monitor that after t_{VDD5_OV} time switches off the drivers except the MRD, OUT13, OUT14, OUT21, OUT25. To switch on again the output it is necessary to send again the START command and to write the CONTROL registers.

It is present a VDD5 over voltage flag, VDD5_OV, that is latched and cleared after reading. This flag does not inhibit the drivers switch on.

The 3.3 V voltage is obtained through a linear regulator. The precision is $\pm 2\%$ with $I_{max} = 100$ mA.

Over-current protection is provided and operates together with thermal sensor OT4.

The condition that switches off the V3V3 is the logic of both Thermal Warning and Over Current.

The under-voltage condition is monitored and the non latched information is available V3V3_UV bit.

VTRK1, 2 are two voltage regulators in tracking (± 20 mV) with the VDD5 voltage for Sensors Supply. They can supply sensors with a $I_{max} = 100$ mA. The output voltages can be used in parallel.

VTRK supplies are protected from over voltage due to short to VB with back to back protection and non latched information are available on VTRK1_DIAG and VTRK22_DIAG bits.

Over-current protection is provided as well and operates together with thermal sensor OT1.

The condition that switches off the VTRK 1, 2 is the logic of thermal warning and over current.

The non latched information is available for overload and over temperature conditions in VTRACK_DIAG bit.

If the VB voltage is lower than regulated VDD5 and higher than 4.15 V the value of VDD5 and VTRK1, 2, could be calculated by the following method:

$$V_{DPVDD5} = (R_{ds_{on\ ExtNmos}}) \cdot (I_{VDD5} + I_{V3V3})$$

$$V_{DPvtrk1} = (R_{ds_{onVTRK1}}) \cdot I_{VTRK1}$$

$$V_{DPvtrk2} = (R_{ds_{onVTRK2}}) \cdot I_{VTRK2}$$

Figure 16. Graphic representation of the calculation method

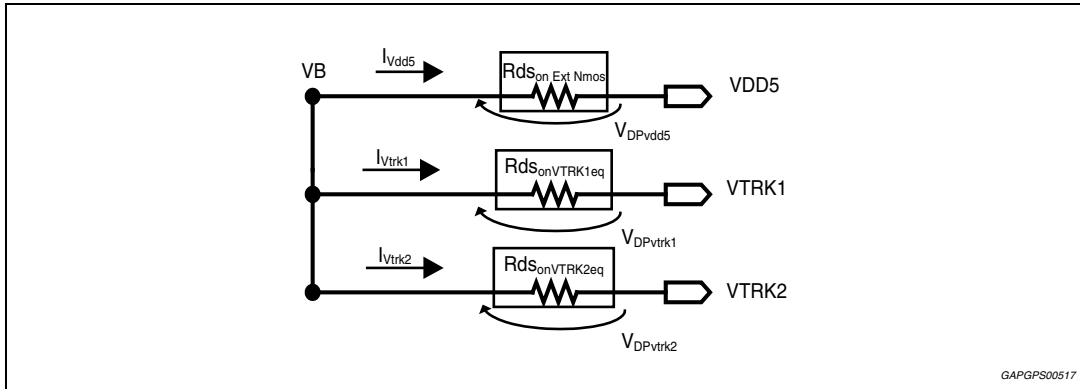

$$VDD5 = VB - (V_{DPVdd5})$$

$$VTRK\ 1, 2 = VB - (V_{DPVtrk1,2})$$

While V3V3 keeps working as expected till VB = 4.15 V

Table 12. Voltage regulators external components required

Pin	Symbol	Parameter	Min	Typ	Max	Suggested part number
VTRK1	C _{TRK1}	External VTRK1 capacitor	100 nF	-	1 μF	C1005X7R1C104K--0.1μF C1608X7R1H104K--0.1μF
VTRK2	C _{VTRK2}	External VTRK2 capacitor	100 nF	-	1 μF	
VDD5	C _{VDD5}	External VDD5 capacitor	1 μF	-	10 μF	C2012X7R1E105K--1μF C1608X7R1C105K-- μF C3216X7R1H105K--1μF C3225X7R1E106K--10μF C3225X7R1C106K--10μF
	Ext MOS	External N-MOS	-	-	-	IRFZ24NSTRL; STD20NF06L (testing reference); NTD18N06L; HUF76419D3

Table 12. Voltage regulators external components required (continued)

Pin	Symbol	Parameter	Min	Typ	Max	Suggested part number
V3V3	C _{V3V3}	External V3V3 capacitor	1 μF	-	10 μF	C2012X7R1E105K--1μF C1608X7R1C105K--1μF C3216X7R1H105K--1μF C3225X7R1E106K--10μF C3225X7R1C106K--10μF
CP	CP	External charge pump capacitor	-20%	100nF	+20%	-

Capacitor legend:

1H → 50 V

1E → 25 V

1C → 16 V

X7R → -40 to 125 °C ±15%

K → -40 to 125 °C ±10%

Note: Others N-MOSFET can be used provided that they have similar threshold voltage and input capacitance; however regulator transient performances may have deviation to be checked.

PCB layout Note: The C_{in} capacitor on VB line should be put as close as possible to the drain of external MOS. The suggestion PCB layout is as below.

Figure 17. Circuit and PCB layout suggested

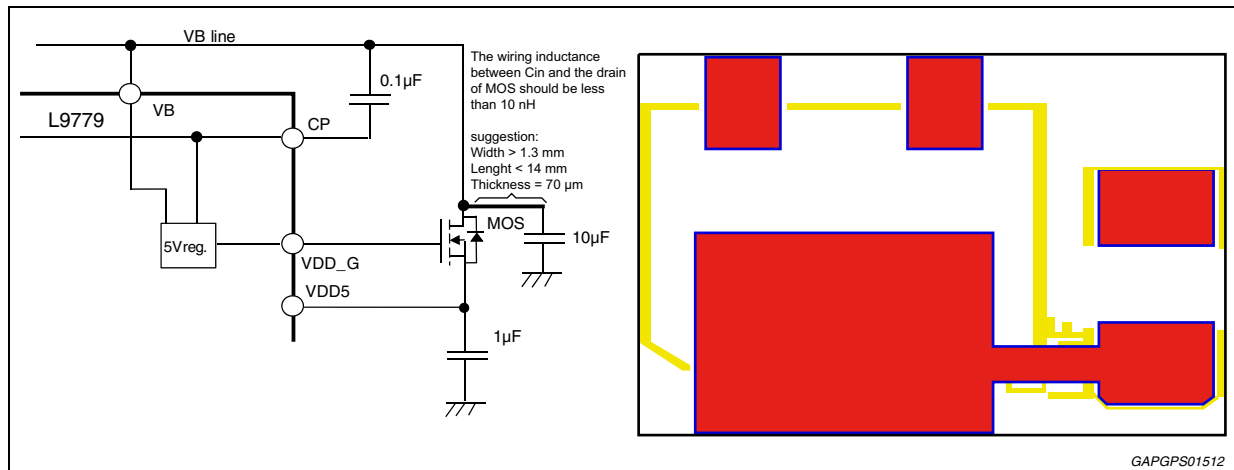

Table 13. VB Power supply electrical characteristics

Pin	Symbol	Parameter	Test Condition	Min	Typ	Max	Unit
VB	I_b	Quiescent current from VB pin	VB = 16 V Min. load on regulator outputs ⁽¹⁾	-	-	50	mA
	I_{Leak}	Standby current	VB = 16V; VKEY_ON = GND Guaranteed at room temp.	-	-	10	μ A
			VB = 16V; VKEY_ON = GND Guaranteed at hot temp.	-	-	100	
	VB_UV_H	Under voltage switch on threshold high	MRD, Low battery channels switch-on in power up	-	-	4.8	V
	VB_UV_L	Under voltage switch off threshold Low	MRD, Low battery channels switch-off	3.5	-	4.145	
	VB_OV_UP	Over voltage switch off threshold	-	-	-	32	V
	VB_OVh	Over voltage threshold hysteresis	-	0.3	-	1	V
	VB_OV_DO WN	Over voltage switch off threshold	-	28.5	-	-	V
	t_{VBOV1}	Filter time for drivers turn-off	Tested by scan	63	85	107	μ s
t_{VBOV2}	Filter time for regulators turn-off	Tested by scan	11	15	19	ms	

1. Min. load on regulator output is $V_{trk1} = 1$ mA, $V_{trk2} = 1$ mA, $V_{3V3} = 5$ mA, VDD5 is open. (5 mA on V3V3 is from VDD5)

Figure 18. VB overvoltage diagram

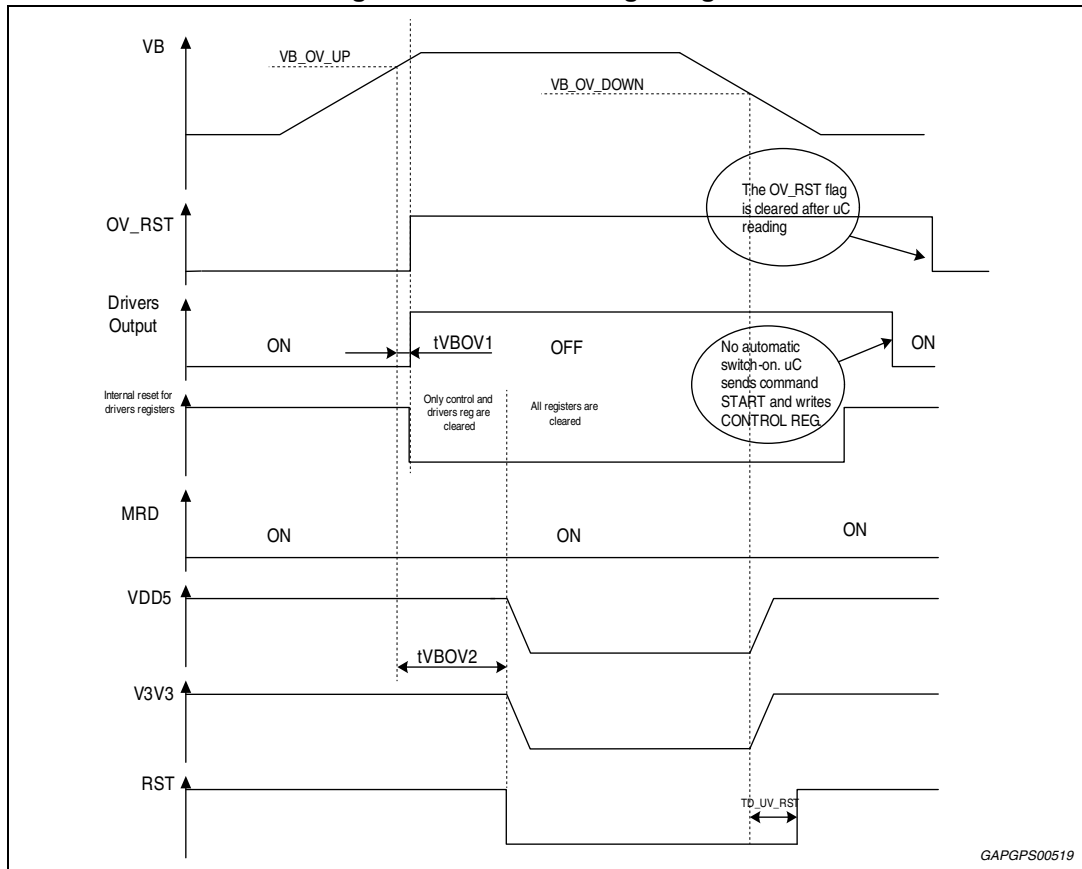

Table 14. Linear 5 V regulator electrical characteristics

Pin	Symbol	Parameter	Test condition	Min	Typ	Max	Unit
VDD5	VDD5	Output voltage 5 V	$I_{VDD5} = 5$ to 400 mA $V_{bat} = 6-18$ V	4.9	5	5.1	V
	VDD5	Transient load regulation	Square wave on VDD5, $\Delta I_{DD5} = \pm 100$ mA; $F_0 = 5$ kHz; $t_r = t_f = 0.5$ μ s; within the output current range NO reset occurs. $C_{out} = 1$ μ F $C_{out} = 10$ μ F	4.8 4.85	5 5	5.2 5.15	V
	$S_{r_{power-up5}}$	Output voltage slew rate at power-up	$I_{vdd5} = 50$ mA; $C_{out} = 10$ μ F	5	15	25	V/ms
	V_{line_5}	Line regulation voltage	$I_{VDD5} = 5$ to 400 mA 6 V < V_b < 18 V	-	-	25	mV
	V_{load_5}	Load regulation voltage		-	-	25	mV
	$VDD5_{Drift}$	Total output VDD5 voltage drift	$C_{out} = 1$ μ F (parameter validated in reliability test)	-	-	100	mV

Table 14. Linear 5 V regulator electrical characteristics (continued)

Pin	Symbol	Parameter	Test condition	Min	Typ	Max	Unit
VDD5	SVR _{VDD5}	Supply voltage 5 V rejection	C _{out} = 10 µF; 4 V _{pp} , V _B mean 9 V, f = 20 kHz	40	-	-	dB
	VDD_OS	Max overshoot at switch on	V _{bat} = 18 V C _{out} = 1 µF R _{out} = 100 Ohm	-	-	5.2	V
		Max overshoot exiting from cranking	Not tested, is guaranteed by design.	-	-	5.2	V
	T _{delay_REG}	-	Tested by scan ⁽¹⁾	0.75	1	1.25	ms
	VDD_UV_low	VDD5 undervoltage low threshold	-	4.5	-	VDD5 (typ.) -150mV	V
	VDD_UV_hys	VDD5 undervoltage hysteresis	-	50	-	-	mV
	VDD_UV_high	VDD5 undervoltage high threshold	-	4.5	-	VDD5 (typ.) -40 mV	V
	VDD_OV_high	VDD5 overvoltage high threshold	-	5.8	-	6.2	V
	VDD_OV_hys	VDD5 overvoltage hysteresis	-	310	-	460	mV
	VDD_OV_low	VDD5 overvoltage low threshold	-	5.5	-	5.9	V
	t_VDD5_OV	VDD5 overvoltage filter time	Tested by scan ⁽¹⁾	-	100	-	µs
	TfUV_Reset	VDD5 under voltage reset filter	Tested by scan ⁽¹⁾	25	50	75	µs
VDD_G	VDD_G	External device voltage at pin VDD_G	V _B = 4.5 V	9.5	-	-	V
	Vgs_clamp	External N-DMOS Vgs clamp	I _{clamp} = 20 mA	-	VDD5 +10	-	V
	I _g	Driver capability	V _B = 6-18 V Open loop, VDD5 = VDD_G = 0 V	500	-	-	µA
	I _{g_rdson}	Driver capability	V _B = 4.5 V = VDD_G, open loop, VDD5 = 0 V (charge pump current capability to keep ext MOS in R _{dson} mode during crank)	160	-	-	µA
-	F _{cp}	Oscillator frequency	V _B = 6-18 V	F _{cp} (typ.) -5%	9.984	F _{cp} (typ.) +5%	MHz

1. All tests by scan parameters have 25% tolerance.

6.6 Charge pump

The L9779WD-SPI charge pump could be active if the battery supply voltage is smaller than 12 V or be permanently active by setting the capful bit enable or disable. Charge pump provides a permanent voltage of at least 5 V above U_{bat} when U_{bat} is higher than 6 V with an external load current at pin CP of 50 μA additional to the L9779WD-SPI internal loads.

Once U_{bat} overvoltage is detected ($V_{B_OV_th} > 28 V$), the charge pump will be switched off automatically no matter the cp_off bit status.

Figure 19. VDD5 overvoltage diagram

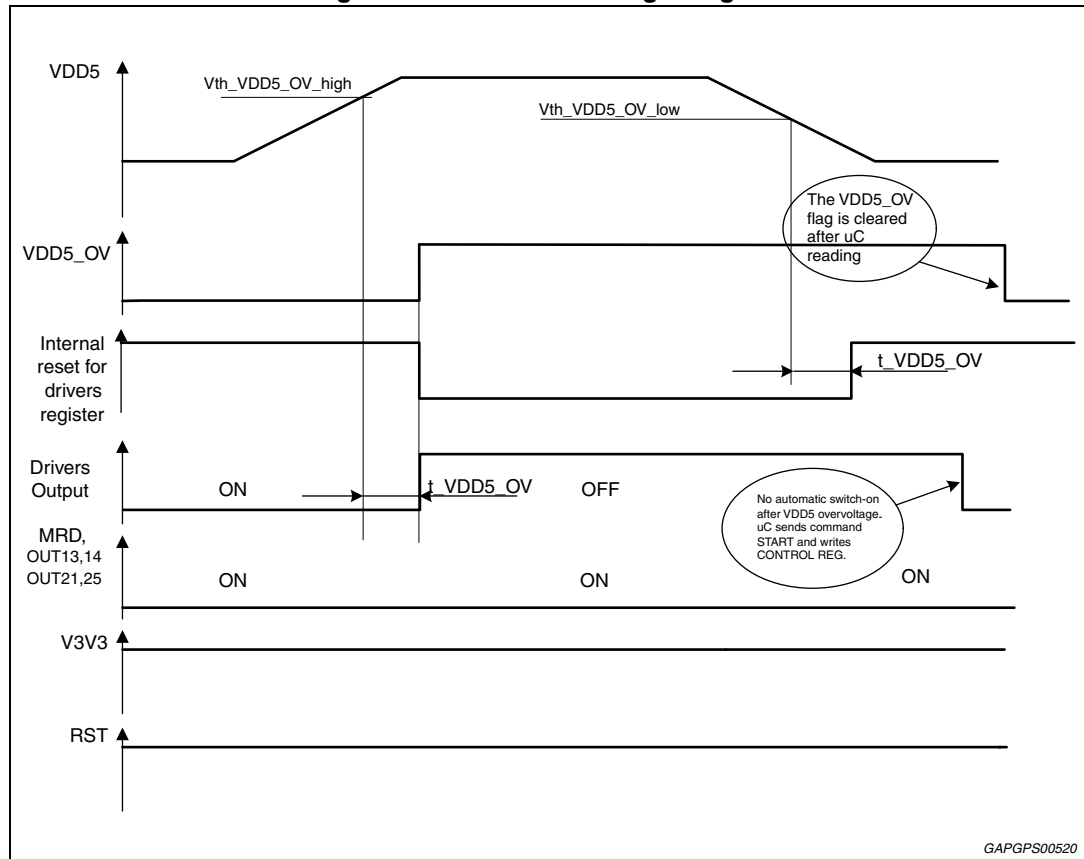

Figure 20. VDD5 vs battery: ramp-up diagram

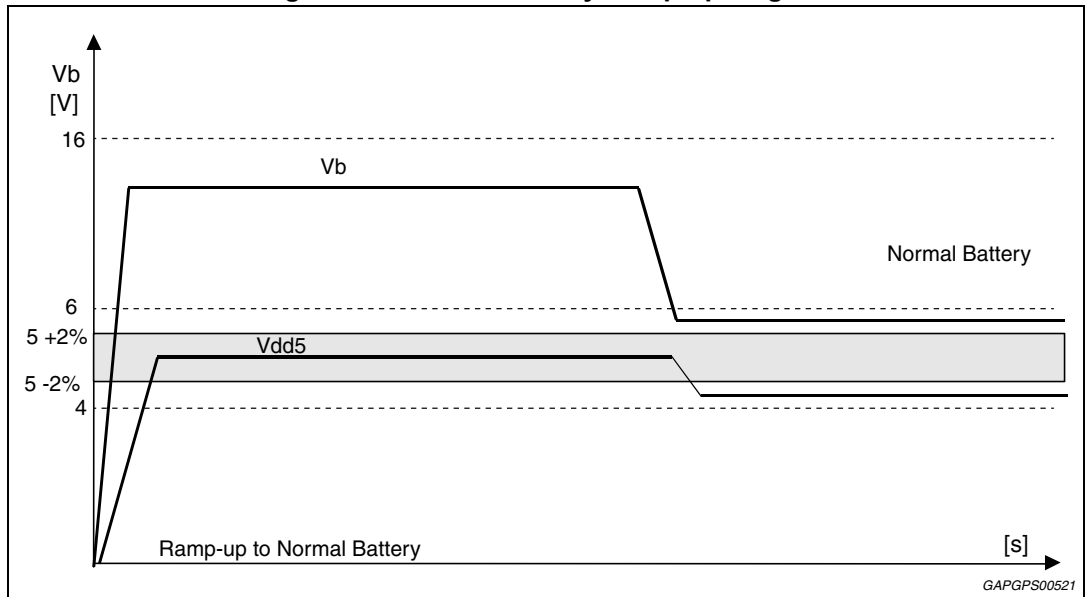

Figure 21. VDD5 vs battery (ramp-down diagram)

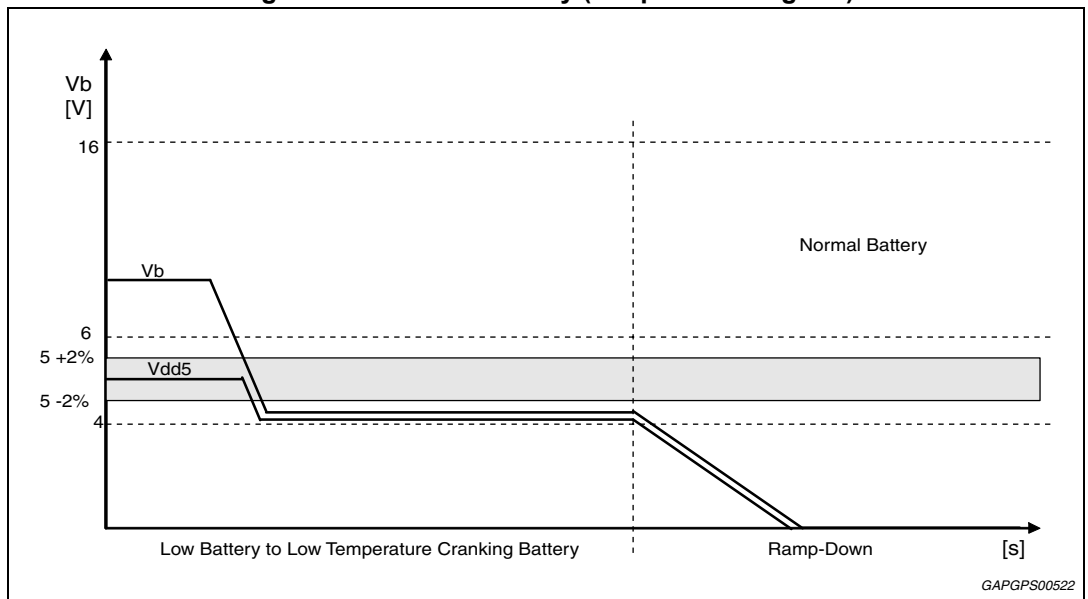

Table 15. Linear 3.3 V regulator electrical characteristics

Pin	Symbol	Parameter	Test condition	Min	Typ	Max	Unit
V3V3	V3V3	Output voltage 3.3 V	IV3V3 = 5-100 mA VB = 6-18 V	3.23	3.3	3.36	V
	V3V3	Output voltage 3.3 V	Square wave on V3V3, ΔIV3V3= ±20 mA; f0 = 5 kHz; tr = tf = 0.5μs; within the output current range	3.2	3.3	3.36	V
	Sr _{power-up5}	Output voltage slew rate at power-up	I _{V3V3} = 12.5 mA C _{out} = 4.7 μF	4	12	20	V/ms
V3V3	I _{V3V3_MAX}	Output current limitation V3V3	V3V3 = 3 V VB = 6-18 V	200	-	500	mA
	V _{line_3}	Line regulation voltage	IV3V3 = 5-100 mA 6V < VB < 18 V	-	-	25	mV
	V _{load_3}	Load regulation voltage	IV3V3 = 5-100 mA 6V < VB < 18 V	-	-	25	mV
	V3V3 _{Drift}	Total output 3V3 voltage drift	C _{out} = 4.7 μF (parameter validated by reliability test)	-	-	100	mV
	SVRV _{3V3}	Supply voltage 3.3 V rejection	C _{out} = 4.7 μF; 4 V _{pp} , VB mean 9 V, f = 20 kHz	40	-	-	dB
	V _{drop_out}	-	VDD5 = 3.3 V; IV3V3 = 100 mA	-	-	200	mV
	V3V3_OS	Max overshoot at switch on	-	-	-	3.45	V
	-	Max overshoot exiting from cranking*1	Not tested, it is guaranteed by design	-	-	3.45	V
	TD_Start_V3V3 ₃	Delay between VDD5> VDD_UV_high and V3V3 switch on	Tested by scan	-	-	1	ms

Table 16. 5V tracking sensor supply electrical characteristics

Pin	Symbol	Parameter	Test condition	Min	Typ	Max	Unit
VTRK_1 VTRK_2	ΔV_{TRK}	Output voltage tracking error	VB = 6-18 V 1 mA < IVTRK < 100 mA	VDD5 -20	-	VDD5 +20	mV
	I_{VTRK_MAX}	Output current limitation VTRK1,2	VTRK = -1V	160	-	400	mA
	V_{LINE_trk}	Line regulation voltage VTRK	VB = 6-18 V 1 mA < IVTRK < 100 mA Ctrk = 1 μ F	-	-	20	mV
	V_{load_trk}	Load regulation voltage VTRK	VB = 6-18 V 1 mA < IVTRK < 100 mA Ctrk = 1 μ F	-	-	20	mV
	I_{sink_VTRK}	Short circuit reverse current	Output shorted to Vbat +2 V	-	-	4	mA
	I_{TH_UVTRK}	Over current threshold VTRK	VB = 6-18 V	101	-	I_{VTRK_MAX}	mA
	V_{TH_OVTRK}	V threshold over voltage VTRK	Ramp on tracking output	5.3	-	-	V
	SVR_VTRK	Supply voltage tracking rejection	$C_{out} = 4.7 \mu F$; VDD5 = 5 V 4 Vpp, VB mean 9 V, f = 20 kHz	40	-	-	dB
	R_{ds_on}	-	VB = 4.8 V; $I_{VTRK1,2} = 100$ mA	-	-	3600	m Ω
	Vos	Over shoot during power up	Clod \geq 470 nF tested with 1 μ F	-	-	5.5	V
			Clod < 470 nF tested with 100 nF	-	-	6	V
V_{ov_filter}	Overvoltage filter time	Test by scan	48	64	80	μ s	

6.7 Main relay driver

Figure 22. Main relay driver controlled by L9779WD-SPI

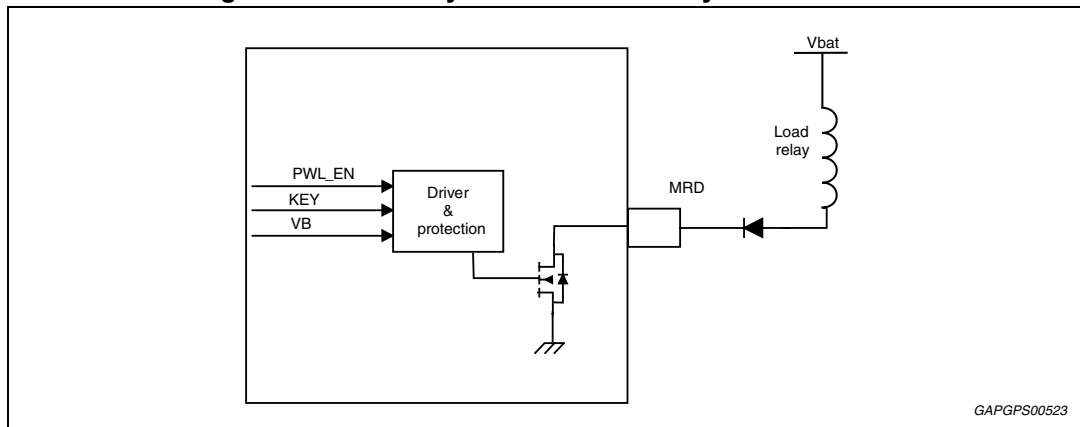

6.7.1 Main relay driver functionality description

Main relay driver MRD is controlled by L9779WD-SPI depending on the voltage levels at pins KEY_ON, VB and the power latch mode set by the μC as described in the previous sections.

The output stage MRD for main-relay-control is realized with a low-side-switch with integrated clamping at VCL voltage realized with a zener diode.

When VB is present ($\text{VB} > \text{VB_LV}$) the MRD driver is protected, in ON condition, against the over temperature fault. When the temperature is above junction the MRD is switched off. After $\theta_{\text{HYSTERESIS}}$ the MRD returns to normal operation automatically.

In case of MRD short to battery without VB present i.e. during start-up sequence, when the current exceeds the IOVC value, this pin will be switched off after a certain filter time $T_{\text{FILTEROVC}}$; to turn on MRD again it is necessary a high to low transition on KEY_ON pin. Refer to scenario 5 ([Figure 29](#)).

In case of MRD short to battery with VB present i.e. during normal mode, when the current exceeds the IOVC value, this pin will be switched off after a certain filter time $T_{\text{FILTEROVC}}$; the μC can try to turn on the MRD using the command MRD_REACT until the VB voltage is above VB_UV. Below this threshold the MRD retries to switch on, then if the fault is still present the MRD switches off and to turn it on again it is necessary a high to low transition on KEY_ON pin. Refer to scenario 6-7-8 ([Figure 30](#), [31](#) and [32](#)).

In every condition the bit MRD_OVC reports that the MRD is currently off due to a previous over current event.

Diagnosis of MRD short to ground may be done as described in the power up/down management unit, switching off the MRD keeping alive all other regulators.

Table 17. Main relay driver electrical characteristics

Pin	Symbol	Parameter	Test condition	Min	Typ	Max	Unit
MRD	R_{DS-on}	Drain –source resistance	$I_{load} = 0.4\text{ A}$; $V_{bat} = 0$ & 13.5 V	-	-	2.4	Ω
	$I_{OUT_{Ik MRD}}$	Output leakage current	$V_{pin} = 13.5\text{ V}$; $V_{bat} = 0$ & 13.5 V	-	-	10	μA
	VS/R	Voltage S/R on/off	$R = 21\ \Omega$, $C = 10\text{ nF}$; $V_{bat} = 0$ & 13.5 V	1	-	10	$\text{V}/\mu\text{s}$
	Vcl	Output clamping voltage	$V_{bat} = 0$ & 13.5 V	42	-	55	V
	I_{max}	Output current	Design info	-	-	0.6	A
	IOVC	Over current threshold	$V_{bat} = 0$ & 13.5 V	0.7	-	1.4	A
	TFILTEROVC	Over current filtering time	Test by SCAN	5.25	7	8.75	μs
	VB_UV	VB threshold for MRD active	$V_{bat} = 0$ & 13.5 V	-	-	4.15	V
	$PW_{clampSP}$	Clamp single pulse ATE test	$I_{load} = 0.5\text{ A}$; single pulse	-	-	15	mJ
	$PW_{clampRP}$	Clamp repetitive pulses reliability test	$I_{load} = 0.25\text{ A}$ Freq = 1 Hz; 1 Mpulse	-	-	4	mJ

6.7.2 MRD scenarios

Figure 23. Scenario 1a: Standard on/off MRD driver with NO power latch mode bit $PSO_{FF} = 0$

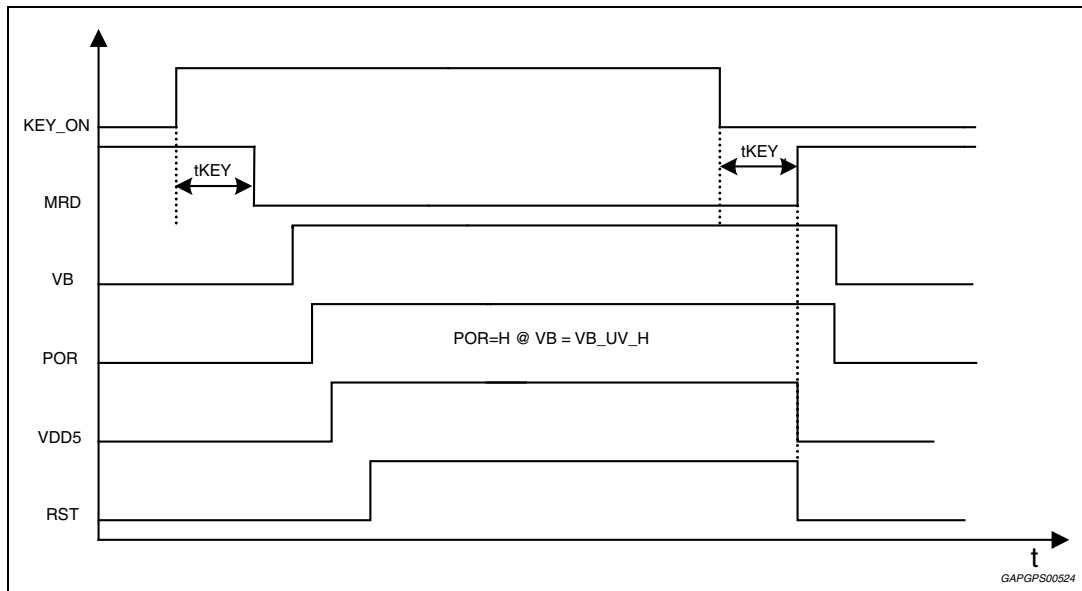

Figure 24. Scenario 1b: Standard on/off MRD driver with NO power latch mode bit PSOFF = 1

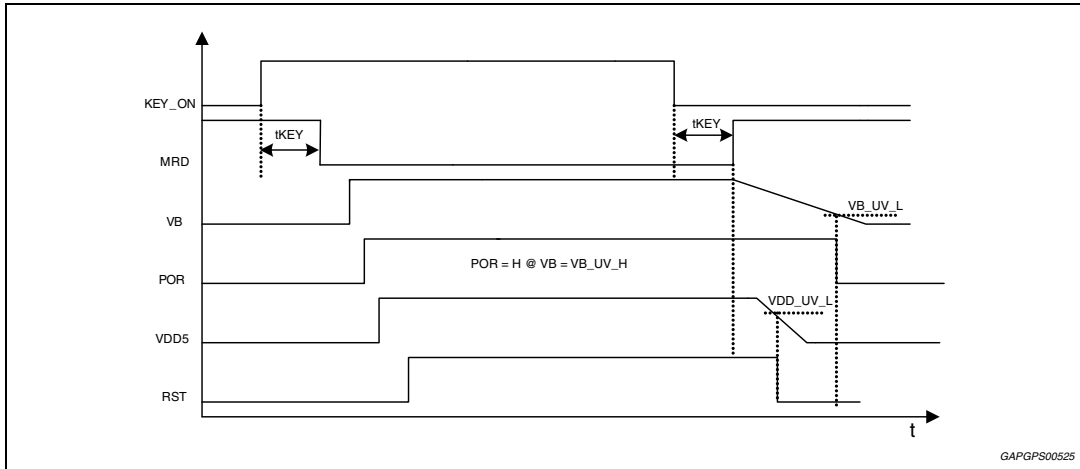

Figure 25. Scenario 2: Standard on/off MRD driver with power latch mode bit PSOFF = 0

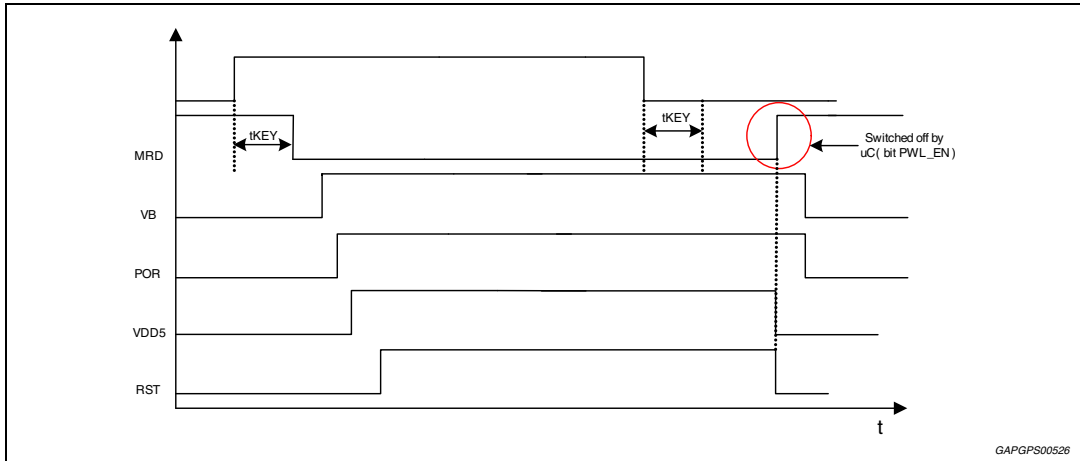

Figure 26. Scenario 3a: Deglitch concept on KEY_ON at start-up

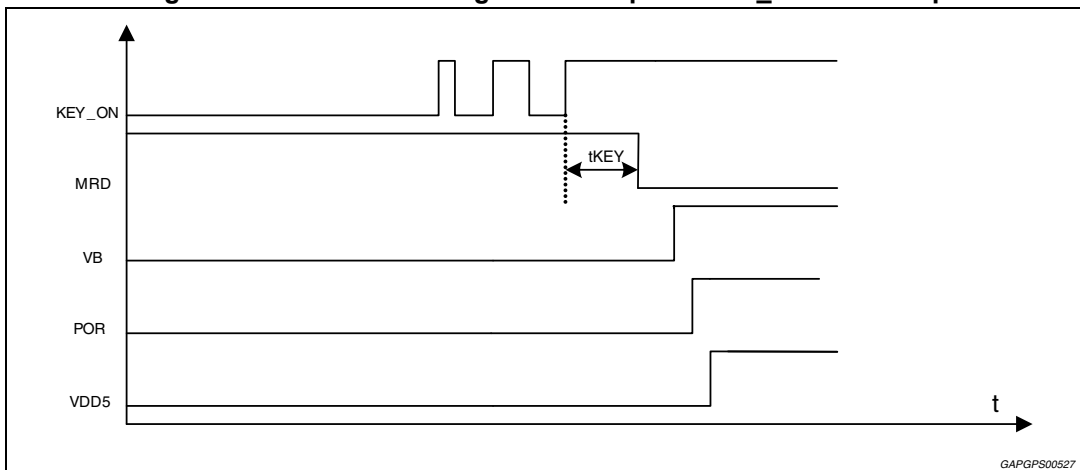

Figure 27. Scenario 3b: Deglitch concept on KEY_ON during ON phase

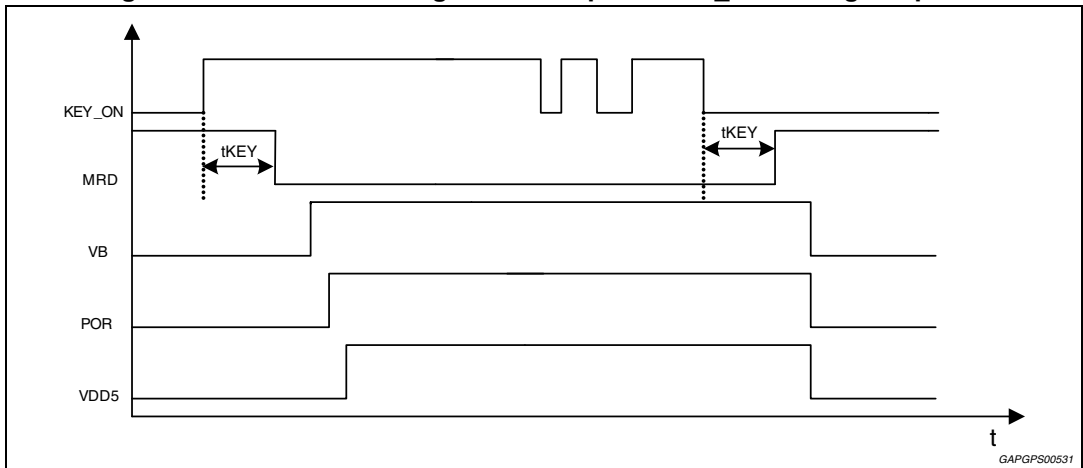

Figure 28. Scenario 4: Non standard on, KEY_ON removed before VB present

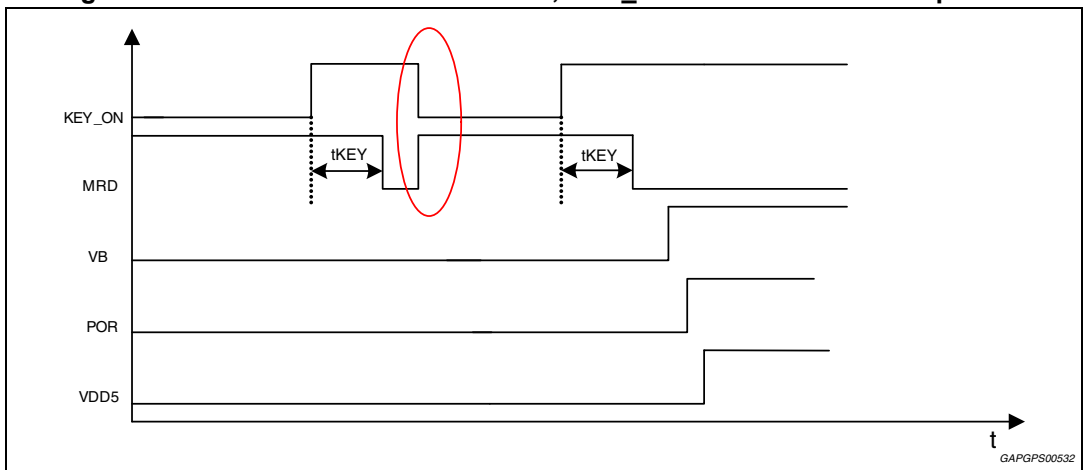

Figure 29. Scenario 5: MRD overcurrent without VB

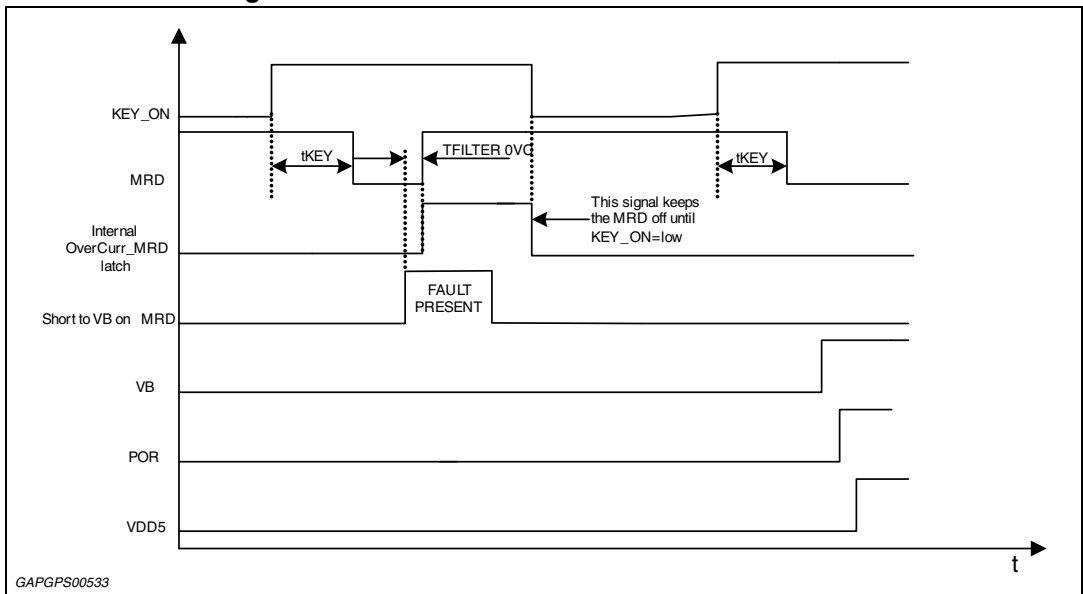

Figure 30. Scenario 6: permanent MRD overcurrent with VBPOR restart

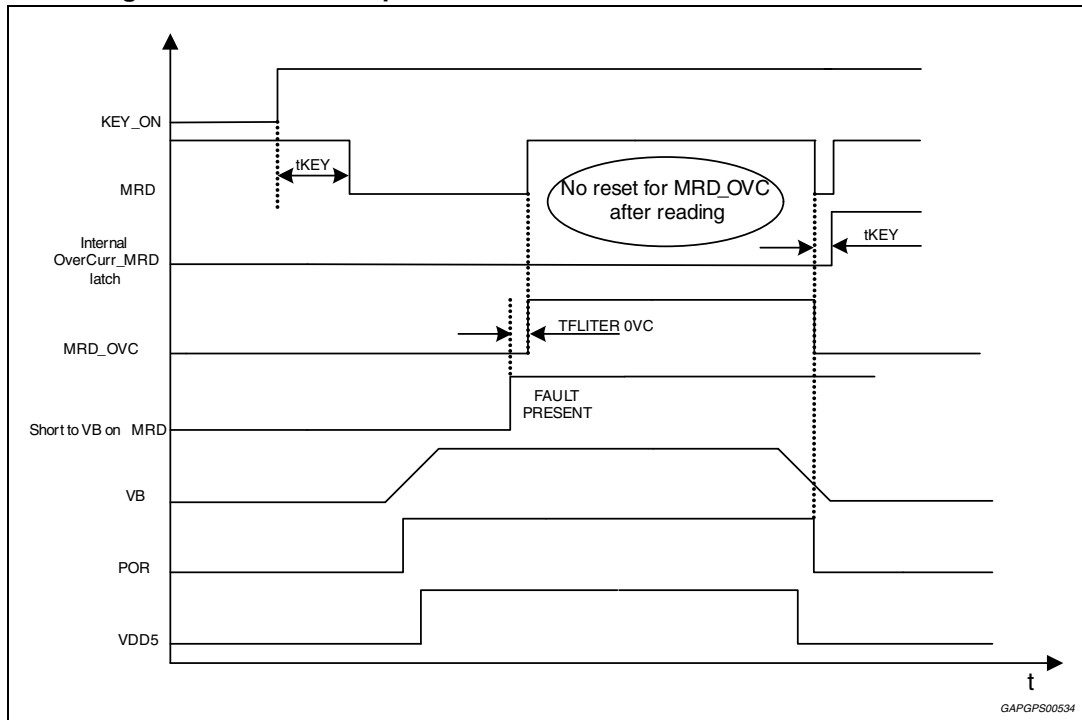

Figure 31. Scenario 7 (temporary MRD overcurrent with VB POR restart)

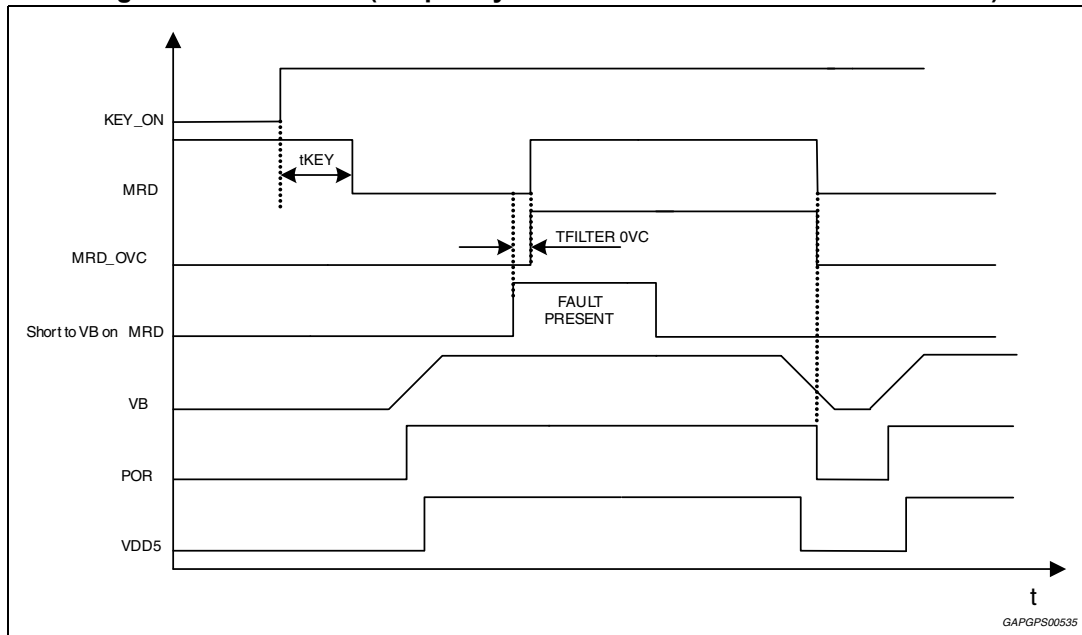
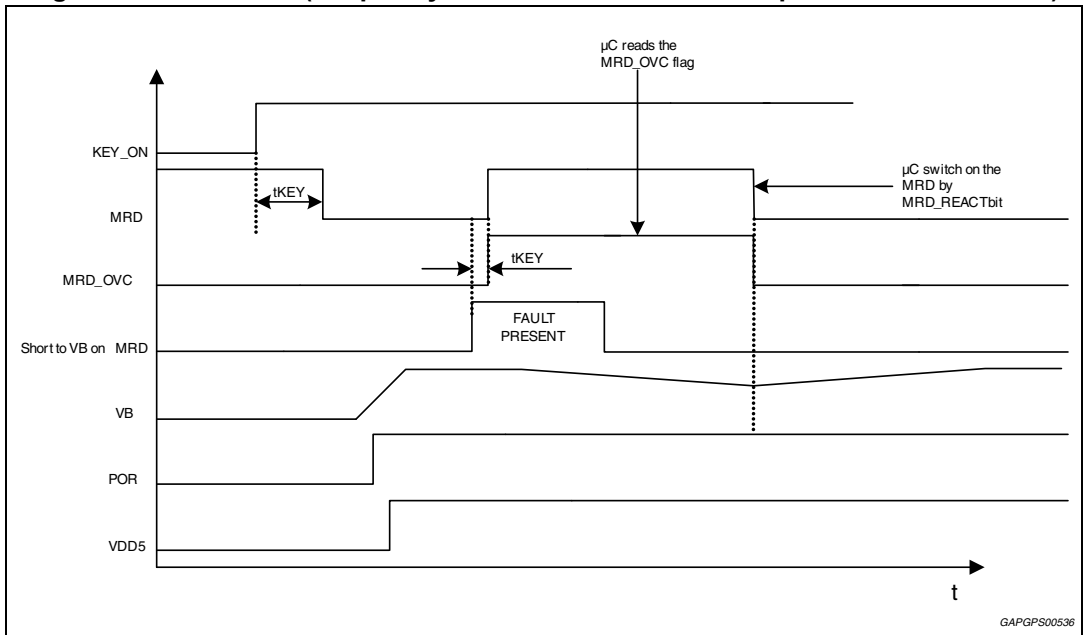

Figure 32. Scenario 8 (temporary MRD overcurrent with VB μ C commands restart)



6.8 Low-side switch function (LSa, LSb, LSd)

6.8.1 LSa function OUT 1 to 5 (Injectors)

Figure 33. LSa function OUT 1 to 5 (Injectors)

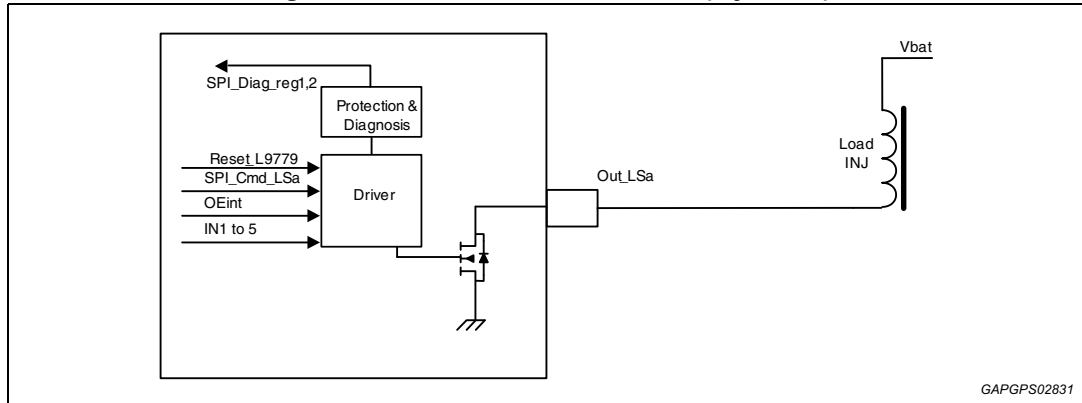

LSa functionality description

LSa are 5 protected low-side drivers with diagnosis and over current protection circuit.

They are driven by logical-AND of SPI control bit and dedicated parallel input IN1...IN5.

The maximum current for OUT1 to 4 is 2.2 A while for OUT5 is 3 A.

When Reset_L9779 signal or OUT_DIS bit is asserted OUT_LSa is switched off.

When an over current fault occurs, the driver switches off with faster slew rate in order to reduce the power dissipation.

The turn on/off time is fixed and the slew-rate is controlled.

Max Cloud = 20 nF.

Table 18. LSa electrical characteristics

Pin	Symbol	Parameter	Test condition	Min	Typ	Max	Unit
OUT 1 to 5	R _{DS-on} LSa	Drain source resistance	I _{load} = 1.25 A	-	-	0.72	Ω
	I _{OUT_ik}	Output leakage current	V _{pin} = 13.5 V	-	-	10	μA
	VS/R	Voltage S/R on/off	Load: 8 Ω, 10 nF From 80% to 30% of V _{OUT}	2	-	6	V/μs
	VS/R GateKill	FAST VR/S off when an OVC fault happens	Load: 8 Ω, 10 nF From 80% to 30% of V _{OUT}	5	-	20	V/μs
	T _{Turn-on} _LSa	Turn-on delay time	From command to 80% V _{OUT} , Load: 8 Ω, 10 nF	-	-	6	μs
	T _{Turn-off} _LSa	Turn-off delay time	From command to 30% V _{OUT} , Load: 8 Ω, 10 nF	-	-	6	μs
	V _{cl}	Output clamping voltage	I _{load} = 1.25 A	53	58	63	V
	PW _{clampSP}	Clamp single pulse ATE test	I _{load} = 1.25 A single pulse	-	-	25	mJ

Table 18. LSA electrical characteristics (continued)

Pin	Symbol	Parameter	Test condition	Min	Typ	Max	Unit
OUT 1 to 4	PW _{clampRP}	Clamp repetitive pulses Freq = 50 Hz (to be verified)	Tc ≤ 30°C; I _{OUT_n} ≤ 1.8 A 13 Mio cycles	-	-	7.5	mJ
			Tc ≤ 65°C; I _{OUT_n} ≤ 1.4 A 130 Mio cycles	-	-	4	
			Tc ≤ 80°C; I _{OUT_n} ≤ 1.4 A 214 Mio cycles	-	-	4	
			Tc ≤ 100°C; I _{OUT_n} ≤ 1.4 A 175 Mio cycle	-	-	4	
			Tc ≤ 115°C; I _{OUT_n} ≤ 1.4 A 45 Mio cycle	-	-	4	
			Tc ≤ 130°C; I _{out_n} ≤ 1.0 A 65 Mio cycle	-	-	3	
			Tc ≤ 145°C; I _{out_n} ≤ 1.0 A 6 Mio cycle	-	-	3	
	Reverse voltage	Body diode reverse current voltage drop (valid for OUT5 also)	I = -2.2 A	-0.5	-	-1.2	V
OUT5	PW _{clampSP}	Clamp single pulse	I _{load} = 1.25 A single pulse	-	-	25	mJ
	PW _{clampRP}	Clamp repetitive pulses Freq = 30 Hz	Tc < 30°C; I _{OUT5} < 0.7 A 21 Mio cycles	-	-	17	
			Tc < 65°C; I _{OUT5} < 0.7 A 70 Mio cycles	-	-	14	
			Tc < 80°C; I _{OUT5} < 0.7 A 115.5 Mio cycles	-	-	14	
			Tc < 90°C; I _{OUT5} < 0.7 A 63 Mio cycles	-	-	14	
			Tc < 100°C; I _{OUT5} < 0.7 A 31.5 Mio cycles	-	-	14	
			Tc < 105°C; I _{OUT5} < 0.7 A 10.5 Mio cycles	-	-	14	
			Tc < 110°C; I _{OUT5} < 0.7 A 7 Mio cycles	-	-	14	
			Tc < 115°C; I _{OUT5} < 0.7 A 5.95 Mio cycles	-	-	14	
			Tc < 120°C; I _{OUT5} < 0.7 A 5.25 Mio cycles	-	-	12	
			Tc < 125°C; I _{OUT5} < 0.7 A 4.9 Mio cycles	-	-	12	
			Tc < 130°C; I _{OUT5} < 0.7 A 4.55 Mio cycles	-	-	12	

Table 18. LSa electrical characteristics (continued)

Pin	Symbol	Parameter	Test condition	Min	Typ	Max	Unit
OUT5	PW _{clampRP}	Clamp repetitive pulses Freq = 30 Hz	Tc < 135°C; I _{OUT5} < 0.7 A 4.55 Mio cycles	-	-	12	mJ
			Tc < 140°C; I _{OUT5} < 0.7 A 3.5 Mio cycles	-	-	12	
			Tc < 145°C; I _{OUT5} < 0.7 A 3.5 Mio cycles	-	-	12	

Table 19. LSa diagnosis electrical characteristics

Pin	Symbol	Parameter	Test condition	Min	Typ	Max	Unit
OUT 1 to 5	R _{open load}	Min resistor value open load detection	Not tested	500	-	-	kΩ
	I _{max}	Output current	Not tested	-	2.2	-	A
	I _{OV}	Over current threshold	-	3	-	6	A
	T _{FILTEROV}	Over current filtering time	Tested by scan	2	3	4	μs
	T _{FILTERdiagoff}	Filtering open load and short to gnd diag. off	Tested by scan	35	50	65	μs
	T _{d_mask}	Diagnosis Mask time after switch-off	Tested by scan	300	-	500	μs
	V _{HVT}	Open load threshold voltage	-	V _{Outopen} +120mV	-	3	V
	V _{Outopen}	Open load output voltage	Open load condition	2.3	-	2.7	V
	V _{LVT}	Output short-circuit to GND voltage range threshold	-	1.9	-	V _{Outopen} -200mV	V
OUT 1 to 5	I _{OUT_PD}	Output diagnostic pull down current Off state	V _{pin} = 5 V	50	-	110	μA
	I _{OUT_PU}	Output diagnostic pull up current Off state	V _{pin} = 1.5 V	110	160	210	μA
	I _{topen}	Open load threshold current	-	30	-	90	μA

For OUT 5 only the following parameters are different respect to OUT1 to 4.

Table 20. LSa diagnosis electrical characteristics (OUT 5)

Pin	Symbol	Parameter	Test condition	Min	Typ	Max	Unit
OUT 5	I _{max}	Output current	Not tested	-	3	-	A
	I _{OV}	Over current threshold	-	3.7	-	6.9	A

6.8.2 LSb function OUT6, 7 (O2 heater)

Figure 34. LSb function OUT6, 7 (O2 heater)

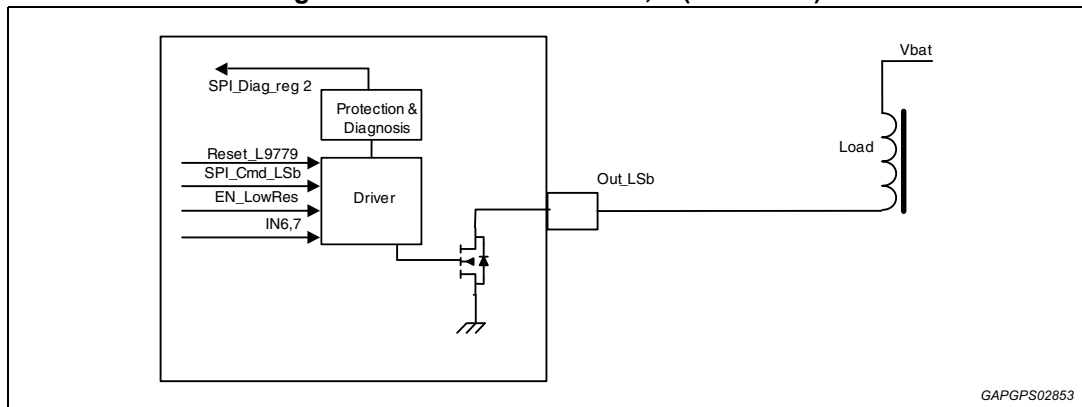

LSb functionality description

LSb are 2 protected low-side drivers with diagnosis and over current protection circuit.

They are driven by logical-AND of SPI control bit and dedicated parallel input IN6, IN7.

The turn on/off time is fixed and the slew-rate is controlled.

When an over current fault occurs, the driver switches off with faster slew rate in order to reduce the power dissipation.

The turn on/off time is fixed and the slew-rate is controlled.

Max Cload = 20 nF.

Table 21. LSb electrical characteristics

Pin	Symbol	Parameter	Test condition	Min	Typ	Max	Unit
OUT 6, 7	R _{DS-on} LSb	Drain source resistance	T = -40°C, I _{load} = 3 A	0.05	-	0.16	Ω
			T = 25°C, I _{load} = 3 A	0.13	-	0.23	Ω
			T = 130°C, I _{load} = 3 A	0.21	-	0.47	Ω
	I _{OUTIk}	Output leakage current	-	-	-	10	μA
	VS/R	Voltage S/R on/off	R = 4.5 Ω, C = 10 nF From 80% to 30% of V _{OUT}	0.5	-	2.5	V/μs
	VS/R GateKill	FAST VR/S off when an OVC fault happens	Load: 8 Ω, 10 nF From 80% to 30% of V _{OUT}	5	-	20	V/μs
	T _{Turn-on} _LSb	Turn-on delay time	From command to 80% V _{OUT} Load: 4.5 Ω, 10 nF	-	-	7.5	μs
	T _{Turn-off} _LSb	Turn-off delay time	From command to 20% V _{OUT} Load: 4.5 Ω, 10 nF	-	-	7.5	μs
	V _{Cl}	Output clamping voltage	I _{load} = 1.5 A	41	45	49	V
PW _{clampSP}	Clamp single pulse ATE test	I _{load} = 1.5 A; single pulse	-	-	25	mJ	

Table 21. LSb electrical characteristics (continued)

Pin	Symbol	Parameter	Test condition	Min	Typ	Max	Unit
OUT 6, 7	PW _{clampRP}	Clamp repetitive pulses Freq = 5 Hz Reliability Test	T _c ≤ 30 °C; I _{OUT_n} ≤ 1.8 A 13 Mio cycles	-	-	7.5	mJ
			T _c ≤ 65°C; I _{OUT_n} ≤ 1.4 A 130 Mio cycles	-	-	4	
			T _c ≤ 80°C; I _{OUT_n} ≤ 1.4 A 214 Mio cycles	-	-	4	
			T _c ≤ 100°C; I _{OUT_n} ≤ 1.4 A 175 Mio cycle	-	-	4	
			T _c ≤ 115°C; I _{OUT_n} ≤ 1.4 A 45 Mio cycle	-	-	4	
			T _c ≤ 130°C; I _{OUT_n} ≤ 1.0 A 65 Mio cycle	-	-	3	
			T _c ≤ 145°C; I _{OUT_n} ≤ 1.0 A 6 Mio cycle	-	-	3	
	Reverse voltage	Body diode reverse current voltage drop	I = -5 A	-1.3	-1	-0.5	V

Table 22. LSb diagnosis electrical characteristics

Pin	Symbol	Parameter	Test condition	Min	Typ	Max	Unit
OUT6, 7	I _{max}	Output current	Not tested	-	5	-	A
	I _{OVc}	Over current threshold	T = -40°C	8.6	-	12.4	A
			T = 25°C	8	-	11.2	A
			T = 130°C	7.8	-	9.9	A
	T _{FILTEROVc}	Over current filtering time	Tested by scan	1.5	-	2.5	µs
	T _{FILTERdiagoff} f	Filtering open load and short to GND diag. off	Tested by scan	7	-	13	µs
	T _{d_mask}	Diagnosis mask delay after switch-off	Tested by scan	300	-	500	µs
	V _{HVT}	Open load threshold voltage	-	V _{Outopen} +120mV	-	3	V
	V _{Outopen}	Open load output voltage	Open load condition	2.3	-	2.7	V
	V _{LVT}	Output short-circuit to GND threshold voltage	-	1.9	-	V _{Outopen} -200mV	V
	I _{OUT_PD}	Output diagnostic pull down current OFF STATE	V _{pin} = 5 V	50	-	110	µA
I _{OUT_PU}	Output diagnostic pull up current OFF STATE	V _{pin} = 1.5 V	-210	-	-108	µA	
I _{topen}	Open load threshold current	-	30	-	90	µA	

6.8.3 LSc function OUT20 (low current drivers)

Figure 35. LSc function OUT20 (low current drivers)

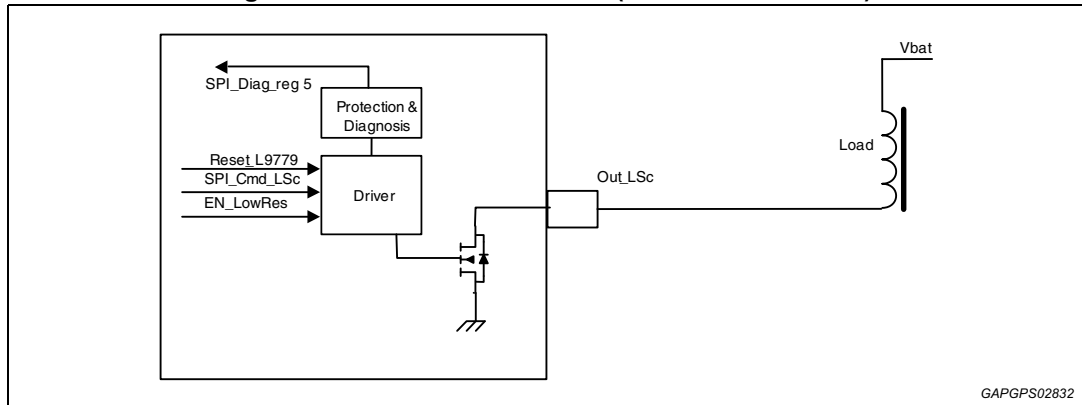

LSc functionality description

LSc is 1 protected Low-Side drivers with diagnosis and over current protection circuit. The off state diagnosis (open load and short to GND) detection can be switched off by OFF_LCDR bit.

It is driven by logical-AND of SPI control bit for OUT20.

When Reset_L9779 signal or OUT_DIS bit is asserted OUT_LSc is switched off.

When an over current fault occurs, the driver switches off with faster slew rate in order to reduce the power dissipation.

The turn on/off time is fixed. During turn-off the slope is fixed by external RC load.

Max Load = 20 nF.

Table 23. LSc electrical characteristics

Pin	Symbol	Parameter	Test condition	Min	Typ	Max	Unit
OUT20	$R_{DS-on\ LSc}$	Drain source resistance	$I_{load} = 50\text{ mA}$	-	-	20	Ω
	I_{OUT_lk}	Output leakage current	$V_{pin} = 13.5\text{ V @hot}$	-	-	10	μA
	$T_{Turn-on_LSb}$	Turn-on delay time	From command to 80% V_{OUT} ; Load: 250 Ω , 10 nF	-	-	5	μs
	$T_{Turn-off_LSb}$	Turn-off delay time	From command to 30% V_{OUT} ; Load: 250 Ω , 10 nF	-	-	5	μs
	V_{cl}	Output clamping voltage	$I_{load} = 50\text{ mA}$	40	45	50	V
	$PW_{clampSP}$	Clamp single pulse ATE test	-	-	-	3.5	mJ
	$PW_{clampRP}$	Clamp repetitive pulses Reliability Test	$T_c \leq 145\text{ }^\circ\text{C}$; $I_{OUT_n} \leq 0.03\text{ A}$ 0.5 Mio cycles	-	-	0.2	mJ
	Reverse voltage	Body diode reverse current voltage drop	$I = -50\text{ mA}$	-0.5	-1	-1.1	V

Table 24. LSc diagnosis electrical characteristics

Pin	Symbol	Parameter	Test condition	Min	Typ	Max	Unit
OUT20	I_{OVC}	Over current threshold	-	70	-	130	mA
	$T_{FILTEROVC}$	Over current filtering time	Tested by scan	2	4	5	μs
	$T_{FILTERdiagoff}$	Filtering open load and short to GND diag. off	Tested by scan	35	50	65	μs
	Td_mask	Diagnosis mask delay after switch-off	Tested by scan	300	-	500	μs
	V_{HVT}	Open load threshold voltage	-	$V_{Outopen} + 160mV$	-	3	V
	$V_{Outopen}$	Output open load voltage	-	2.3	-	2.7	V
	V_{LVT}	Output short-circuit to GND threshold voltage	-	1.9	-	$V_{Outopen} - 200mV$	V
	I_{OUT_PD}	Output diagnostic pull down current Off state	$V_{pin} = 5 V$	50	-	110	μA
	I_{OUT_PU}	Output diagnostic pull up current Off state	$V_{pin} = 1.5 V$	110	160	210	μA
	I_{topen}	Open load threshold current	-	30	-	110	μA
	$V_{S/R ON}$	Voltage R On	$R = 270 \text{ Ohm}$ $C_{load} = 10 \text{ F}$	2	-	6	$V/\mu s$
	$V_{S/R OFF}$	Voltage R Off	From 80% to 30% of V_{OUT}	5	-	14	$V/\mu s$

6.8.4 LSd function OUT13 to 18 (relay drivers)

Figure 36. LSd function OUT13 to 18 (relay drivers)

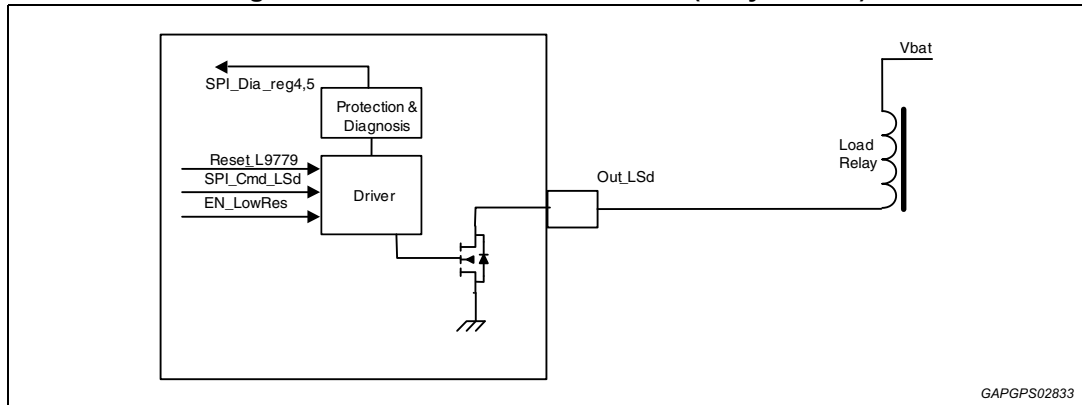

LSd functionality description

LSd are 6 protected Low-Side drivers with diagnosis, and over current protection circuit.

They are driven via SPI interface.

When Reset_L9779 signal or OUT_DIS bit is asserted OUT_LSd is switched off.

The turn on/off time is fixed and the slew-rate is controlled.

OUT13 and OUT14 are able to remain active also during crank pulse when the battery voltage on the VB pin goes below the level VB_LV for a period of time THOLD, this time lapse calculation is triggered by the falling edge of RST. In this situation VDD5 is below undervoltage threshold (VDD_UV) and the micro controller is in reset condition. During the THOLD time the VDD5 supply and the micro controller have to recover and take over control of the output. Otherwise the output is switched OFF after the THOLD time.

The low battery functionality can be enabled/disabled through bit OUT13_EN_LB and OUT14_EN_LB of CONF_REG7.

Table 25. LSd electrical characteristics

Pin	Symbol	Parameter	Test condition	Min	Typ	Max	Unit
OUT 13 to 18	$R_{DS-on\ LSd}$	Drain source resistance	$I_{load} = 0.6\ A$	-	-	1.5	Ω
	$I_{OUT\ lk}$	Output leakage current	$V_{pin} = 13.5\ V$	-	-	10	μA
	$V_{S/R}$	Voltage S/R on/off	$R = 21\ \Omega, C = 10\ nF$ From 80% to 30% of V_{OUT}	2	-	6	$V/\mu s$
	$V_{S/R\ GateKill}$	FAST $V_{R/S}$ off when an OVC fault happens	Load: $8\ \Omega, 10\ nF$; From 80% to 30% V_{OUT} ;	5	-	30	$V/\mu s$
	$T_{Turn-on\ LSd}$	Turn-on delay time	From command to 80% V_{OUT} Load: $21\ \Omega, 10\ nF$	-	-	6	μs
	$T_{Turn-off\ LSd}$	Turn-off delay time	From command to 30% V_{OUT} Load: $21\ \Omega, 10\ nF$	-	-	6	μs
	V_{cl}	Output clamping voltage	$I_{load} = 0.6\ A$	40	45	50	V

Table 25. LSd electrical characteristics (continued)

Pin	Symbol	Parameter	Test condition	Min	Typ	Max	Unit
OUT 13 to 18	PW _{clampSP}	Clamp single pulse ATE test	I _{load} = 0.6 A; single pulse	-	-	15	mJ
	PW _{clampRP}	Clamp repetitive pulses Freq = 1 Hz (to be verified) Reliability Test	T _c ≤ 30 °C; I _{OUT_n} ≤ 0.45 A 1 Mio cycles	-	-	6.5	mJ
			T _c ≤ 80 °C; I _{OUT_n} ≤ 0.3 A 25 Mio cycle	-	-	6.5	
			T _c ≤ 100°C; I _{OUT_n} ≤ 0.3A 20 Mio cycle	-	-	6.5	
			T _c ≤ 130°C; I _{OUT_n} ≤ 0.3 A 5 Mio cycle	-	-	5.5	
Reverse voltage	Body diode reverse current voltage drop	I = -0.6 A	-0.5	-1	-1.1	V	

Min/Max of Reverse Current will be added after BA characterization.

Table 26. LSd diagnosis electrical characteristics

Pin	Symbol	Parameter	Test condition	Min	Typ	Max	Unit
OUT 13 to 18	R _{open load}	Min resistor value open load detection	Not tested	500	-	-	kΩ
	I _{max}	Output current	Not tested	-	0.6	-	A
	I _{OVC}	Over current threshold	-	1	-	2	A
	T _{FILTEROVC}	Over current filtering time	Tested by scan	2	4	5	μs
	T _{FILTERdiagoff}	Filtering open load and short to GND diag. off	Tested by scan	35	50	65	μs
	T _{d_mask}	Diagnosis mask delay after switch-off	Tested by scan	300	-	500	μs
	V _{HVT}	Output voltage open load threshold	-	V _{Outopen} +120mV	-	3	V
	V _{OUTOPEN}	Output open load voltage	Open load condition	2.3	-	2.7	V
	V _{LVT}	Output short-circuit to GND threshold voltage	-	1.9	-	V _{Outopen} -200mV	V
	I _{OUT_PD}	Output diagnostic pull down current off state	V _{pin} = 5 V	50	-	110	μA
	I _{OUT_PU}	Output diagnostic pull up current off state	V _{pin} = 1.5 V	-210	-	-108	μA

Table 26. LSd diagnosis electrical characteristics (continued)

Pin	Symbol	Parameter	Test condition	Min	Typ	Max	Unit
OUT 13 to 18	I_{topen}	Open load threshold current	-	30	-	90	μA
OUT13, 14	T_{HOLD}	Switch on to off delay during low battery voltage operation	Tested by scan	400	-	800	ms
	VB_UV	VB voltage threshold for low battery function	-	-	-	4.15	V

Figure 37. Behavior of OUT13, 14, 21, 25 with $VB = VB_{UV}$ for a time shorter than T_{hold} and with a valid ON condition

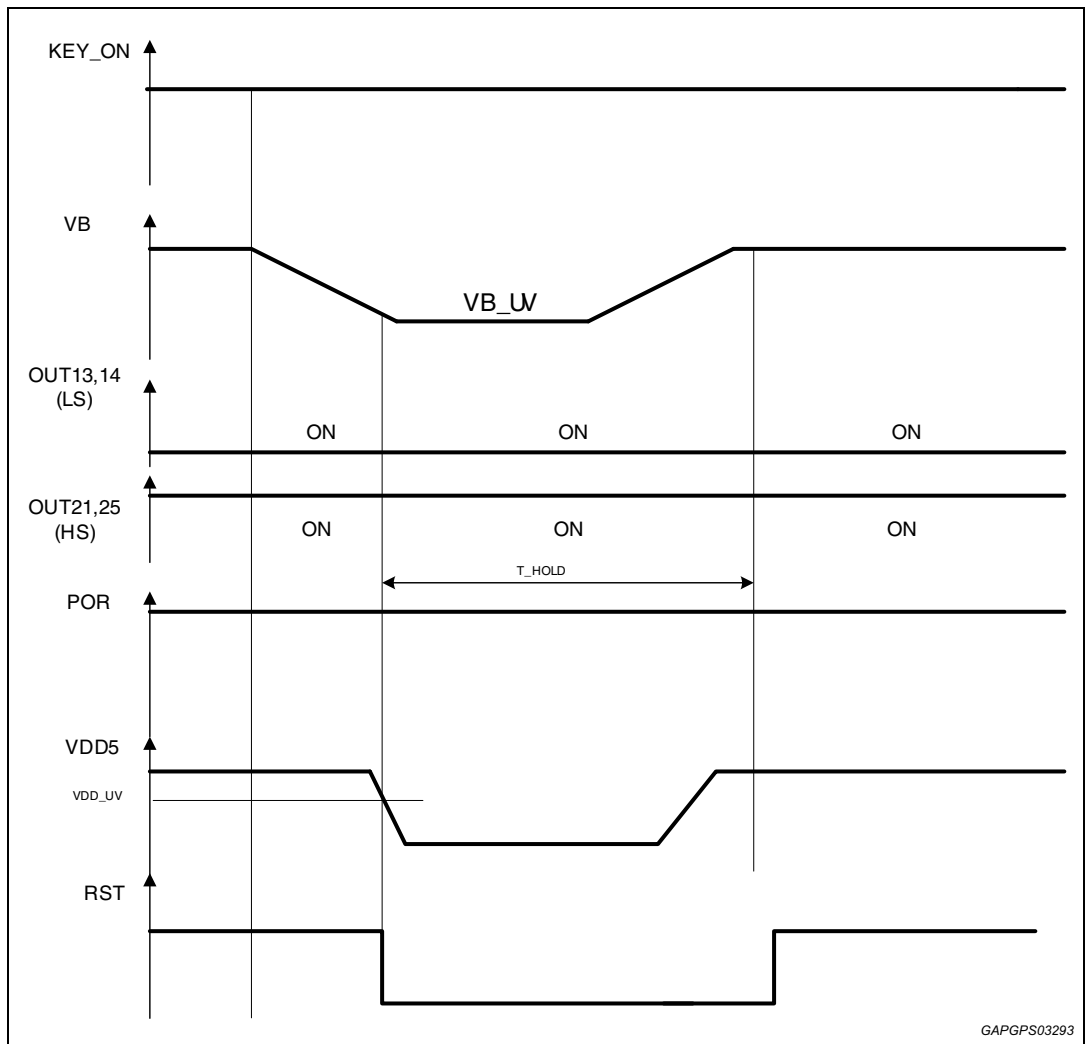

Figure 38. Behavior of OUT13, 14, 21, 25 with $VB = UB_UV$ for a time longer than T_{hold} and with a valid ON condition

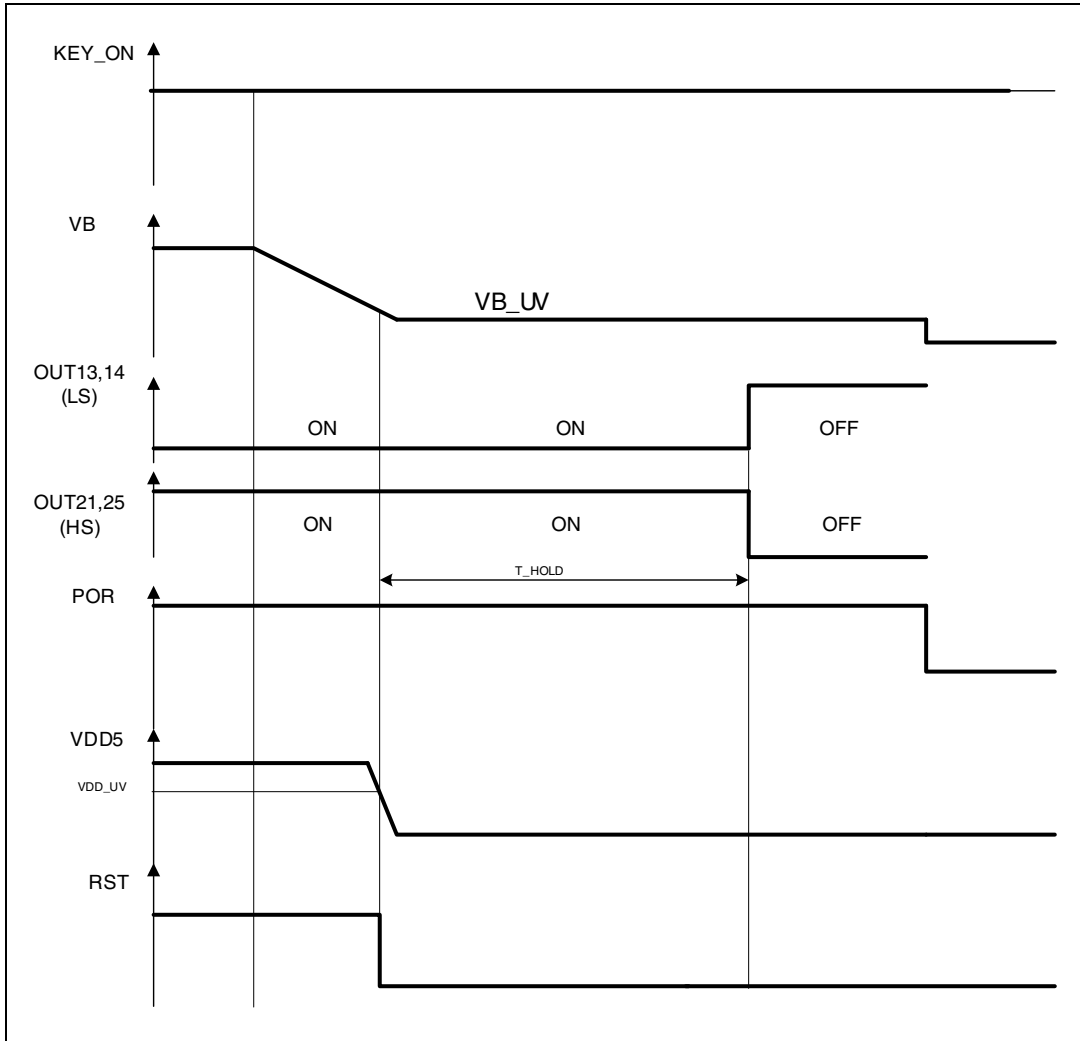
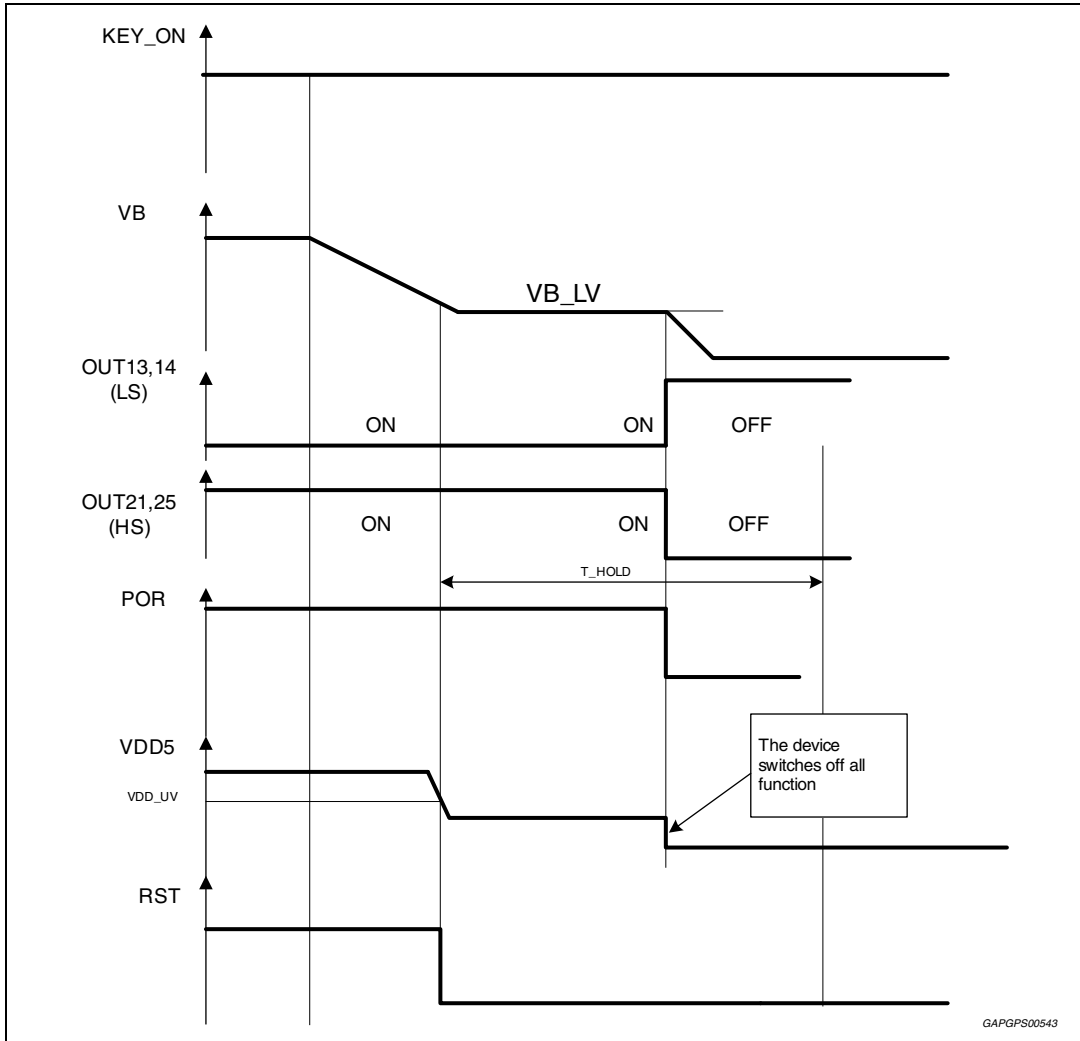

Figure 39. Behavior of OUT13, 14, 21, 25 with VB that drops lower than POR threshold during cranking



6.9 LSa, LSb, LSc, LSd diagnosis

Each channel locally detects and writes its own fault or no-fault condition (codified on 2 bit according to the table FAULT ENCODING CONDITION).

- short circuit to battery or overcurrent for all the outputs during ON condition.
- open load or short to GND during OFF condition.

The faults are latched and reset every Read Diag operation.

In OFF condition the first fault detected is latched and can be overwritten only by the ON condition fault.

Channel “on”

Short to Vb:

Current diagnosis is the result of a comparison between driver load current and internal IOVC thresholds.

If: $I_{LOAD} > IOVC$ for $t > T_{FILTEROVC}$ the driver is switched off and the fault is set, latched and reset every Read Diag operation.

When the fault occurs the driver is switched off with a controlled slew-rate.

The driver switches on AGAIN in the following conditions:

- If command goes LOW and then HIGH again
- If command remains active the driver is switched automatically on at every Read Diag operation.

Short to GND:

Not available.

Open Load:

Not available.

Channel “off”

Short to Vb:

Not available.

Short to GND & open load:

In open load condition an internal circuit drives the OUTx voltage to VOUTOPEN with a maximum pull-up/down current of IOU_T_PU and IOU_T_PD.

Diagnosis is done comparing driver output voltage with internal voltage thresholds VHVT and VLVT: if the voltage is below VLVT a short to GND is detected, if the voltage is above VLVT and below VHVT an open load is detected and if the voltage is above VHVT no fault is present.

Diagnosis status is masked for Td_{mask} time after the off event occurs to allow the output voltage to reach the proper value.

Short to GND and open load are filtered with T_{FILTERdiagoff} time.

Diag status is latched and reset at every Read Diag operation.

For LSc(OUT20) the IOOUT_PD/IOOUT_PU can be switched off by OFF_LCDR bit and therefore the Open Load and Short To GND detections are not available.

Figure 40. LSx diagnosis circuit

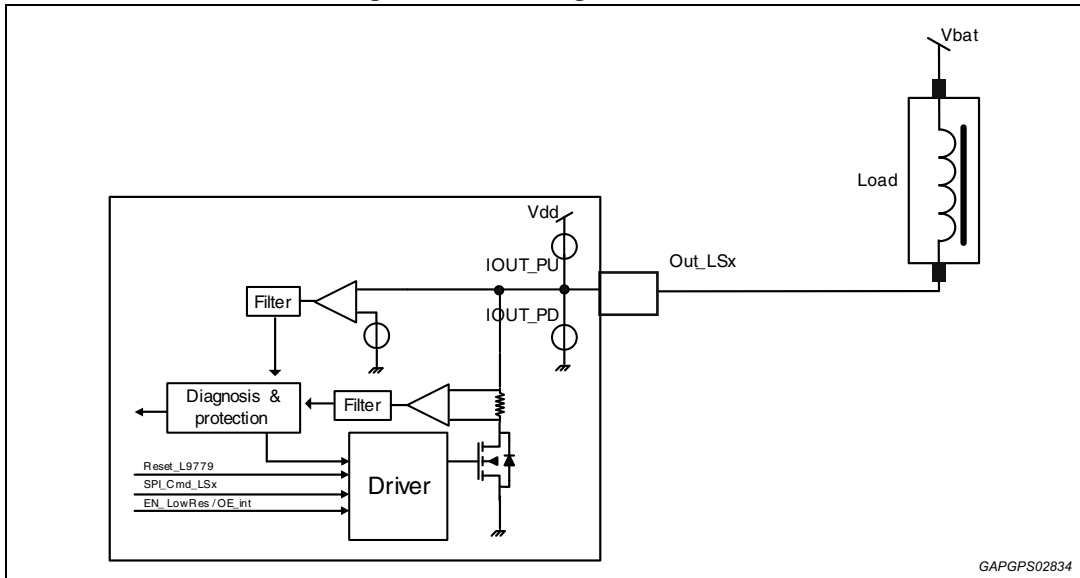

Table 27. Fault encoding condition

Bit n+1	Bit n	Description
1	1	Power stage OK no Fail
0	1	Open Load OL
1	0	Short circuit to VB/over current SGB
0	0	Short circuit to GND SCG

Figure 41. Fault encoding condition diagram

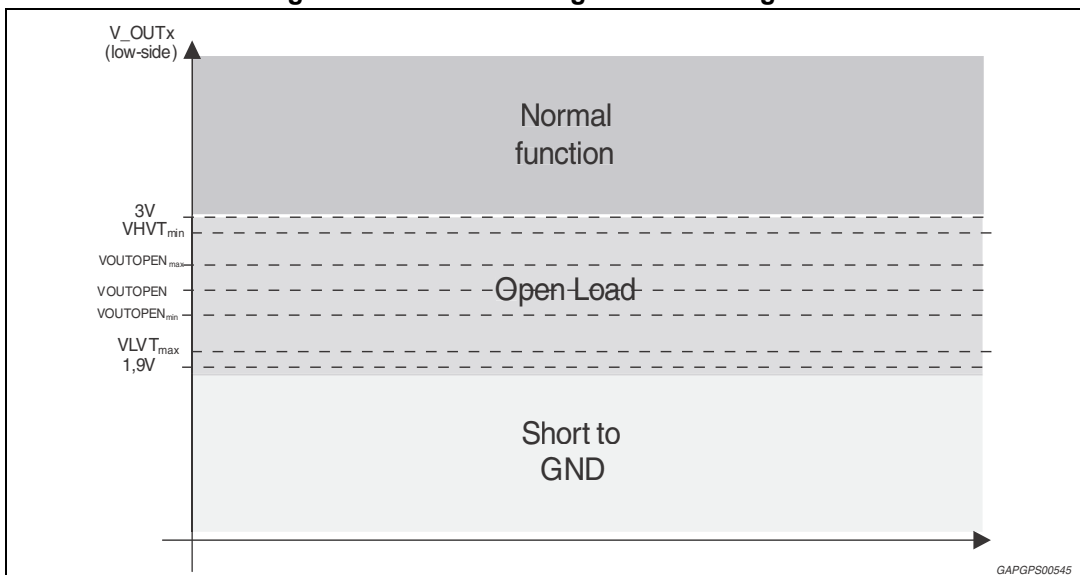
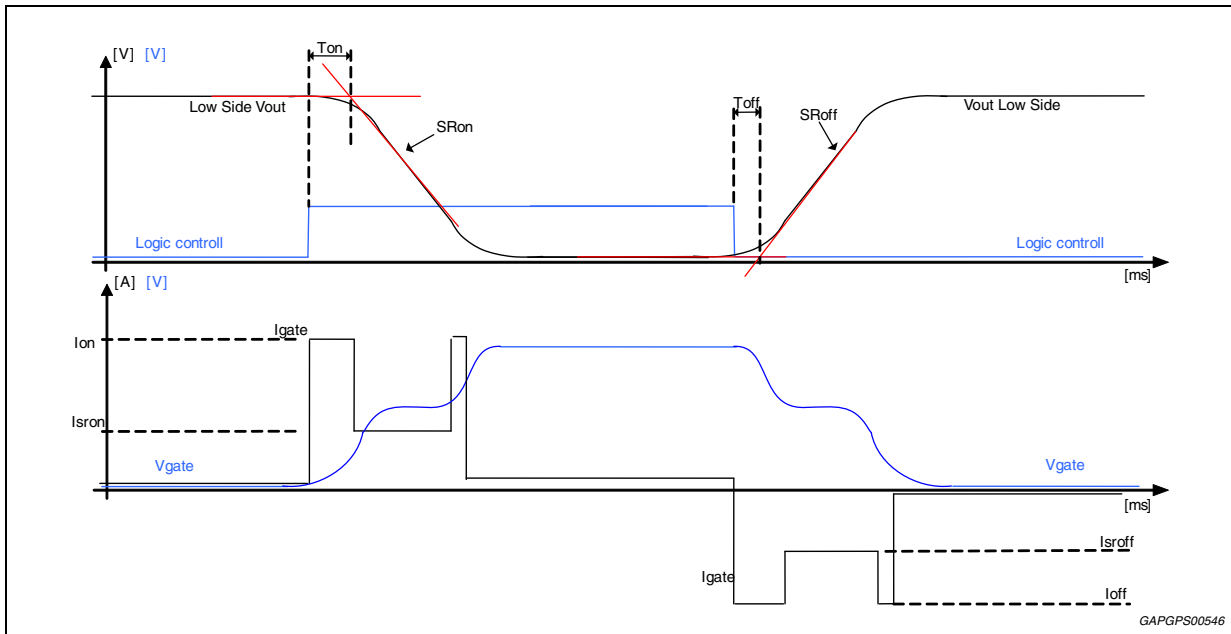
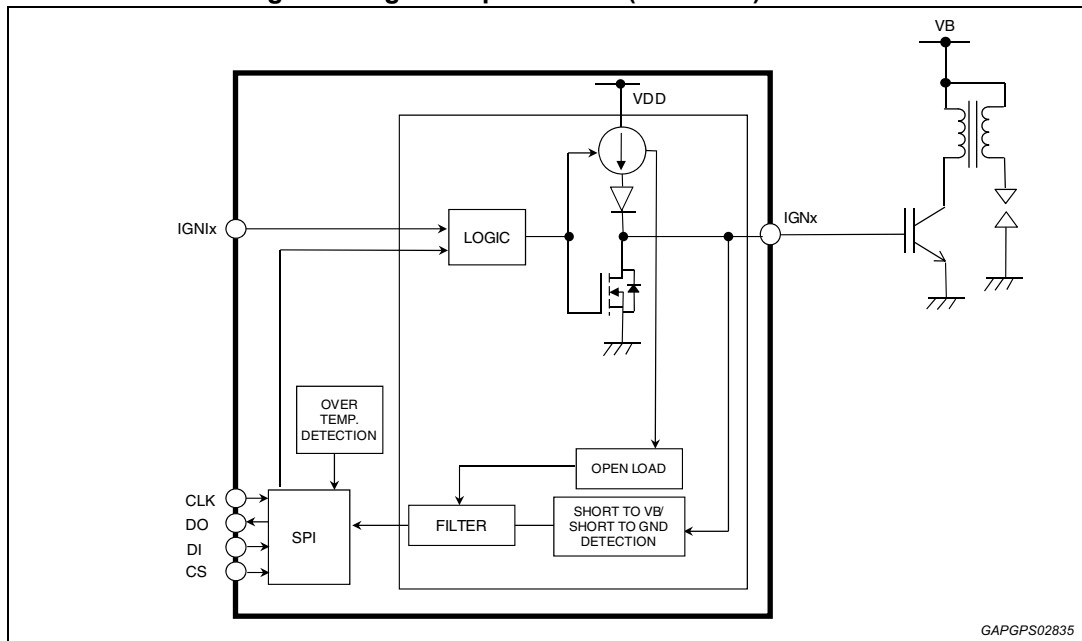

Figure 42. LSx ON/OFF slew rate control diagram



6.10 Ignition pre-drivers (IGN1 to 4)

Figure 43. Ignition-pre drivers (IGN1 to 4) circuit



6.10.1 Ignition pre-drivers functionality description

The 4 ignition pre-drivers are push-pull output with diagnosis and over current protection circuit. They can drive IGBT Darlingtons transistors.

The load is switched on with a current and switched off with I_LS_cont current.

They are driven by logical-AND of SPI control bit and dedicated parallel input IGN1...IGN4.

When Reset_L9779 signal or OUT_DIS bit is asserted, output IGNx becomes high impedance.

By SPI command it is possible to have the low-side stage always off, in this case there is an external pull down resistor that discharges The IGNx output in Off phase. This Bit is present in CONFIG_REG2 bit0 and its name is LS_IGN_OFF.

Table 28. Ignition pre-drivers electrical characteristics

Pin	Symbol	Parameter	Test condition	Min	Typ	Max	Unit
IGN1 to 4	VDD5	Supply voltage range	Info only	4.9	-	5.1	V
	Vign	Output voltage high level	I_cont = 15 mA	4.35	-		V
	I _{leak_out}	Leakage current	-	-10	-	10	μA
	I _{lim}	High-side current limitation	-	19	-	33	mA
	I_LS_cont	LS path continuous current capability	Add also the R _{DSON} Test	-	-	30	mA
	I_LS_RD S on	LS RDSON	-	3	-	14	Ω
	IOVC	High side over current detection	-	7	-	14	mA
	VLVT	Output short-circuit to Gnd threshold voltage	-	1.6	1.8	2	V
	Vign_scb	SCB detection voltage	-	VDD5 +0.1V	-	VDD5 +2V	-
	I _{ol}	OL detection current	-	100	-	850	μA
	T _{don}	Output on delay time	Clgn = 10 nF	-	-	10	μs
	T _{ign_filt}	OVC/Open load diagnosis filter time, Test by scan	-	50	-	100	μs
	T _r	Output on rise time	Clgn = 10 nF	-	-	10	μs
	T _{doff}	Output off delay time	Clgn = 10 nF	-	-	10	μs
	T _f	Output off fall time	Clgn = 10 nF	-	-	10	μs
	R _{load}	Resistive load	For info only	1	-	10	kΩ
	C _{out}	Output capacitance loads	For info only	4	-	15	nF

Figure 44. Ignition-pre drivers (IGN1 to 4) diagram

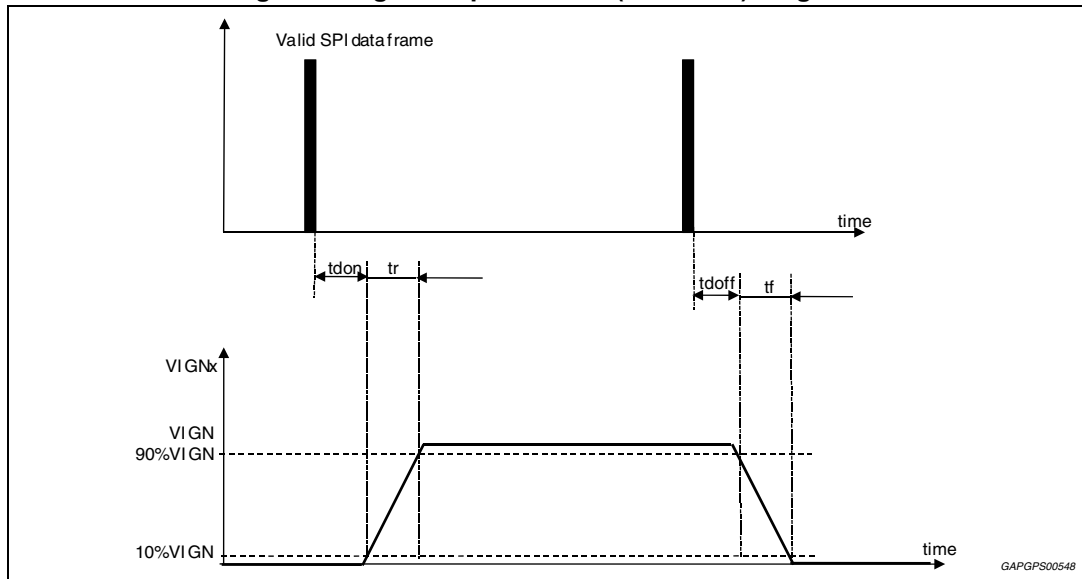

6.10.2 Ignition pre-driver diagnosis

Each channel locally detects and writes its own fault or no-fault condition (codified on 2 bit according to [Table 27: Fault encoding condition](#)).

The detected faults are:

- IGNx short circuit to battery (SCB)
- IGNx open load (OL)
- IGNx short to GND (SCG)

Short to GND

This diagnosis is made in two different ways based on the status of IGN_DIA_SGEN.

If IGN_DIA_SGEN = 1

When the IGNx is on, if for a time longer than Tign_filt, the current is bigger than IOVC, the short to GND fault is detected and the IGNx output becomes high impedance, the fault is latched and is reset at every Read Diag operation.

If IGN_DIA_SGEN = 0

When the IGNx is on, if for a time longer than Tign_filt, the voltage of IGNx is lower than VLVT, the short to GND fault is detected and the IGNx output becomes high impedance, the fault is latched and is reset every Read Diag operation.

The high impedance is removed and IGNx is driven by the command:

- after a Read Diag operation
- if command is switched OFF and ON again.

Open load

When IGNx is on, if for a time longer than Tign_filt, the current is below Iol the open-load fault is detected, latched and it is reset at every Read Diag operation. IGNx remains always driven.

Short circuit to battery

When the load is on, if the voltage of IGNx is bigger than the Vign_scb threshold for a time longer than Tign_filt the SCB fault is detected and the output IGNx becomes high impedance.

When the load is off, if the voltage of IGNx is bigger than the Vign_scb threshold for a time longer than Tign_filt the SCB fault is detected and the output IGNx becomes high impedance.

The SCB fault has a higher priority with respect to the OL fault.

According to the IGN_DIA_MODE bit, two behaviours are possible:

1. Latch mode

The fault is latched and is reset at every Read Diag operation.

The high impedance is removed and IGNx is driven by the command:

- after a Read Diag operation
- if the command is switched OFF and ON again.

2. No latch mode

The fault is not latched and if the voltage of IGNx is lower than the Vign_scb threshold for a time longer than Tign_filt the fault state disappears and the high impedance is removed.

6.11 Configurable power stages (CPS) (OUTA to OUTD)

6.11.1 Configurable power stages functionality description

L9779WD-SPI half bridges with 1 low side N-channel power stage and 1 high side P-channel power stages [OUTA to OUTD] that can be arranged as follows using the CPS_CONF bit (default H-bridge):

- The low side of each half can be connected in parallel to obtain a low side driver with lower Rdson resistance.

For three reasons outputs are switched in parallel:

- a) to increase current capability (please see electrical characteristic)
- b) to reduce power dissipation (please see electrical characteristic)
- c) to increase clamp energy capability (please see electrical characteristic) The max. clamping energy is probably less than the sum of the corresponding max. clamping energies.

Parallel connection of Low-side power stages is possible as the control bit to turn-on and off the power stages is allocated in the same register. Unlike the H-bridge configuration, no coherency check is done.

When configured for stepper motor driving the motor movement is controlled through bit EN, DIR and PWM input SPI bit (see [Table 29](#)).

In single power stage configuration HS and LS power stages (OUT21...OUT28) can be used as single power stages, and any of them can be connected in parallel to each other (same type).

Stepper is controlled by the logic AND between PWM input pin and PWM SPI bit. Thus to control it by PWM input, SPI PWM bit must be set first, and to do it by SPI PWM bit, PWM input pin must be set first.

If the bit EN=1, the writing of bit PWM from 0 to 1 leads to the next step of the turn on sequence. The writing of bit PWM to 0 left unchanged the MOS of the bridge that is ON. The step is done only if the PWM bit goes from 0 to 1.

The order of the turn-on sequence is defined by the bit DIR.

Table 29. Configuration of the stepper motor

PWM	EN	DIR	H-bridge 1 Power on	H-bridge 2 Power on
X	0	X	None	None
1	1	1	OUTA_HS, OUTB_LS	OUTD_HS, OUTC_LS
1	1	1	OUTA_HS, OUTB_LS	OUTC_HS, OUTD_LS
1	1	1	OUTB_HS, OUTA_LS	OUTC_HS, OUTD_LS
1	1	1	OUTB_HS, OUTA_LS	OUTD_HS, OUTC_LS
1	1	0	OUTA_HS, OUTB_LS	OUTD_HS, OUTC_LS
1	1	0	OUTB_HS, OUTA_LS	OUTD_HS, OUTC_LS
1	1	0	OUTB_HS, OUTA_LS	OUTC_HS, OUTD_LS
1	1	0	OUTA_HS, OUTB_LS	OUTC_HS, OUTD_LS

The initial stepper position, after power-on, is the one with OUTA_HS, OUTB_LS ON in Hbridge1 and with OUTD_HS, OUTC_LS ON in Hbridge2.

If configured as H-bridges the internal logic prohibits that the low-side and the high-side switch of the same half-bridge will be switched on simultaneously.

In the below diagram the stepper motor operation is available.

Figure 45. Stepper motor operation diagram

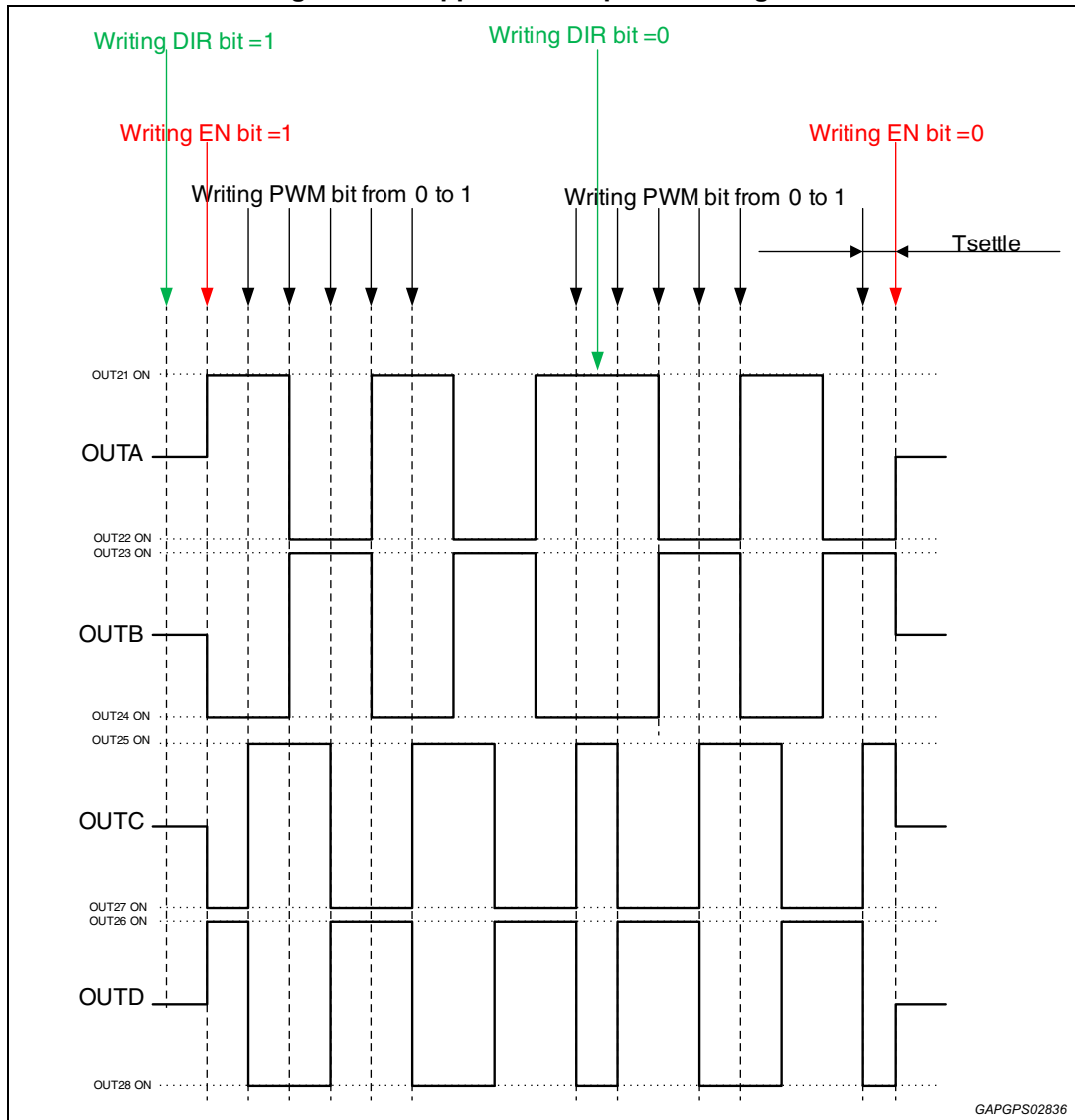

The writing of DIR bit and PWM bit cannot be done in the same time, at least two consecutive SPI frames are necessary.(if done the stepper will move one step in the old direction).

The writing of EN bit and PWM bit cannot be done in the same time, at least two consecutive SPI frames are necessary. (If done it is supposed that only the EN bit has been received).

Table 30. Half bridge 1

H-bridge1	Comment	Nominal current	Ron max	Switch off current (min.)	Clamping (typ.)
OUTA	High-side P-Ch	0.6 A	1.7 Ω	1 A	N/A
	Low-side N-Ch	0.6 A	1.5 Ω	1 A	45 V

Table 31. Half bridge 2

H-bridge2	Comment	Nominal current	Ron max	Switch off current (min.)	Clamping (typ.)
OUTB	High-side P-Ch	0.6 A	1.7 Ω	1 A	N/A
	Low-side N-Ch	0.6 A	1.5 Ω	1 A	45 V

Table 32. Half bridge 3

H-bridge3	Comment	Nominal current	Ron max	Switch off current (min.)	Clamping (typ.)
OUTC	High-side P-Ch	0.6 A	1.7 Ω	1 A	N/A
	Low-side N-Ch	0.6 A	1.5 Ω	1 A	45 V

Table 33. Half bridge 4

H-bridge4	Comment	Nominal current	Ron max	Switch off current (min.)	Clamping (typ.)
OUTD	High-side P-Ch	0.6 A	1.7 Ω	1 A	N/A
	Low-side N-Ch	0.6 A	1.5 Ω	1 A	45 V

Figure 46. Stepper motor driver: H-bridge1

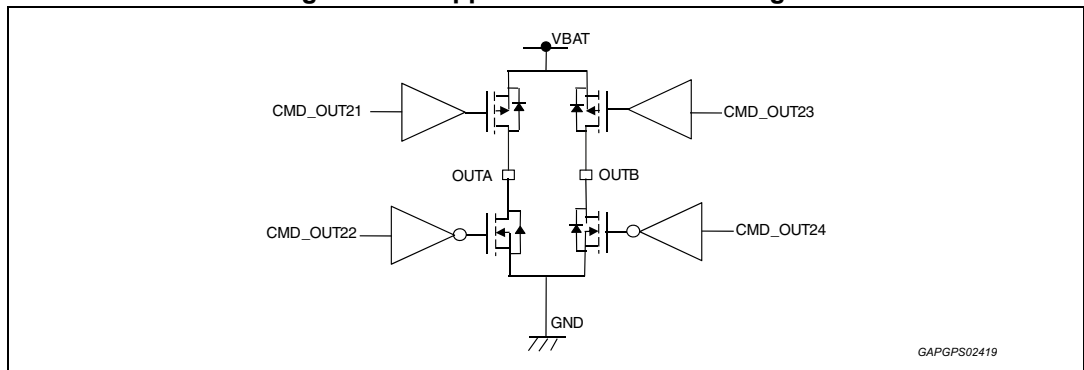
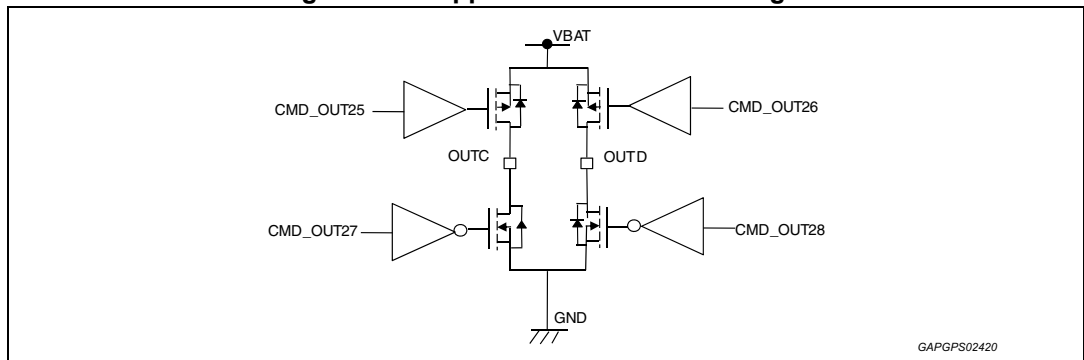

Figure 47. Stepper motor driver: H-bridge2



6.11.2 Diagnosis of configurable power stages (CPS)

All CPS have fault diagnostic functions:

- Short-circuit to battery voltage: (SCB) can be detected if switches are turned on
- Short-circuit to ground: (SCG) can be detected if switches are turned off
- Open load: (OL) can be detected if switches are turned off
- Over temperature: (OT) will be detected with the general thermal warning(OT2)

Diagnosis is different for configuration as full-bridges or as single power stages. The faults are coded in different way and are stored in diagnostic registers.

In each configuration the registers can be read via SPI. With the beginning of each read cycle the registers are cleared automatically.

In each configuration there is one central diagnostic bit F2 for fault occurrence at any output.

6.11.3 Diagnosis of CPS [OUTA to OUTD] when configured as H-bridges

Stepper motor driver OFF diagnosis (output in high impedance state).

In OFF condition Short to GND/Short to VB or Open Load condition is continuously detected through a deglitch filter Tdgc_off, after Tmask_step masking time to filter ON/ OFF transition. To avoid false diagnostic due to motor residual movement, the off command (EN bit=0) must be sent Tsettle time after the last valid on command PWM bit written to 1 (one couple of HS and LS switched on). A fault longer than deglitch time is latched.

Off state diagnostic fault can be overwritten by on state fault.

Off state fault does not prevent the stepper from switching on. The latched fault is cleared by reading the diagnosis data registers via SPI - and so resetting the diagnosis registers.

An Off state due to a wrong command sent by SPI interface does not activate the Off diagnosis.

Stepper motor driver ON diagnosis (Output driven by SPI CONTR_REG bit)

In ON condition when over current fault is detected and validated after digital filtering time Tdgc_ON, the bridge is turned OFF and the fault is latched. The bridge is turned ON again by SPI command. The latched fault is cleared by reading the diagnosis data registers via SPI and so resetting the diagnosis registers.

Over current fault has higher priority over OFF condition faults.

Each Bridge has dedicated fault diagnosis register H1_DIAG, H2_DIAG.

In ON condition if the current in the load current is lower than I_OPEN_LOAD for a time longer than Tdgc_ol_on, an Open load condition is detected

It could be necessary two steps of the stepper motor operation to detect the real kind of fault, in this case as first diagnosis the fault is "Fault detection running" and with the next PWM command it is possible to understand if the fault is an OPEN LOAD or an OVERCURRENT/SHORT to GND.

The Faults "DETECTION_RUNNING" & "OPEN LOAD" are latched during the during rise & fall edge of low-side driver command, if the fault disappeared during these phases the fault condition is no latched:

- The FAULT DETECTION RUNNING is no latched, the fault comes back to 0 if the current becomes higher than open load threshold, before the switch off of low-side driver.
- The FAULT OPEN LAOD is no latched, the fault comes back to 0 if the current becomes higher than open load threshold, before the switch off of low-side driver.

A diagnostic read will clear the "fault detection running" flag. Anyway the diagnostic will restart.

Figure 48. Stepper motor driver "off" diagnosis time diagram

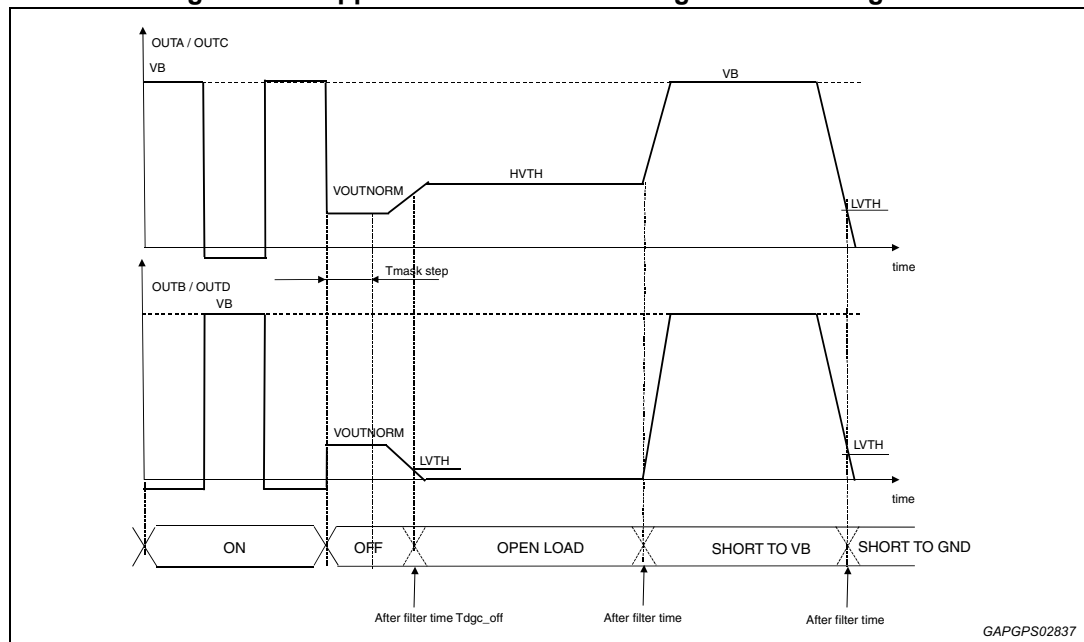
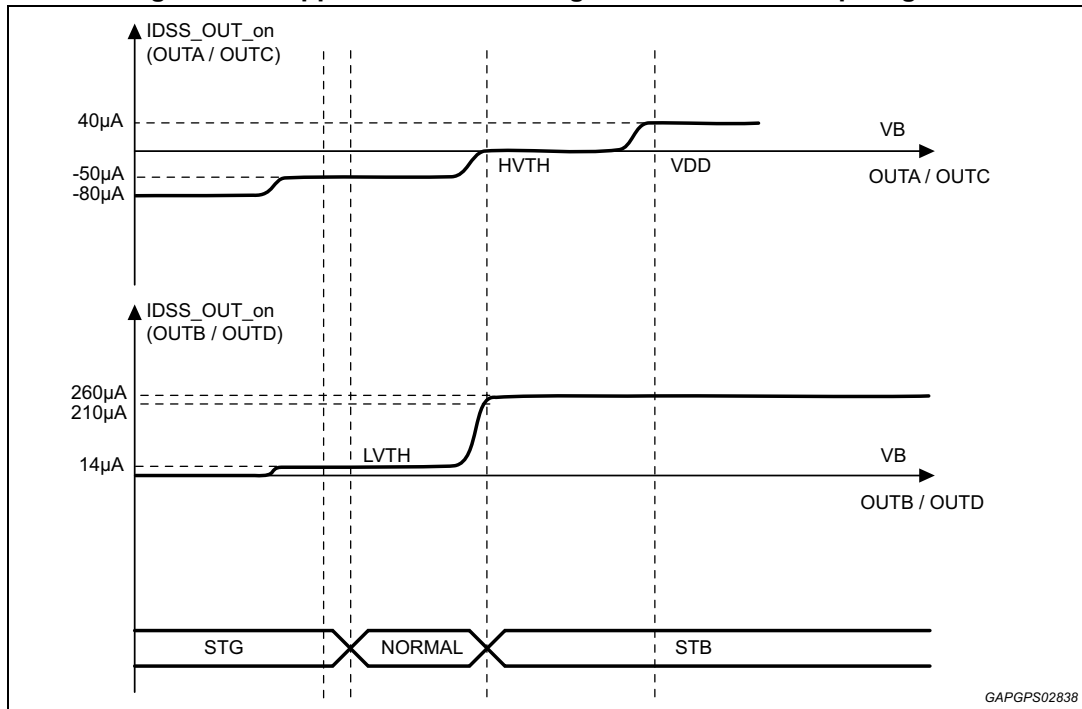

Figure 49. Stepper motor driver diagnosis I-V relationship diagram



Note: this wave shows the I/V relationship of pin current and pin voltage when OUTA(OUTC) short to OUTB(OUTD) and force the pin voltage from 0 V to VB in typical condition. For example, when pin voltage of OUTA = OUTB = 1.5 V, the pull up/down current is about -50 µA for OUTA and about 14 µA for OUTB. When pin voltage of OUTA = OUTB = 5 V, the pull up/down current is about 40 µA for OUTA and about 220 µA for OUTB.

Figure 50. Open load detection during "on" phase

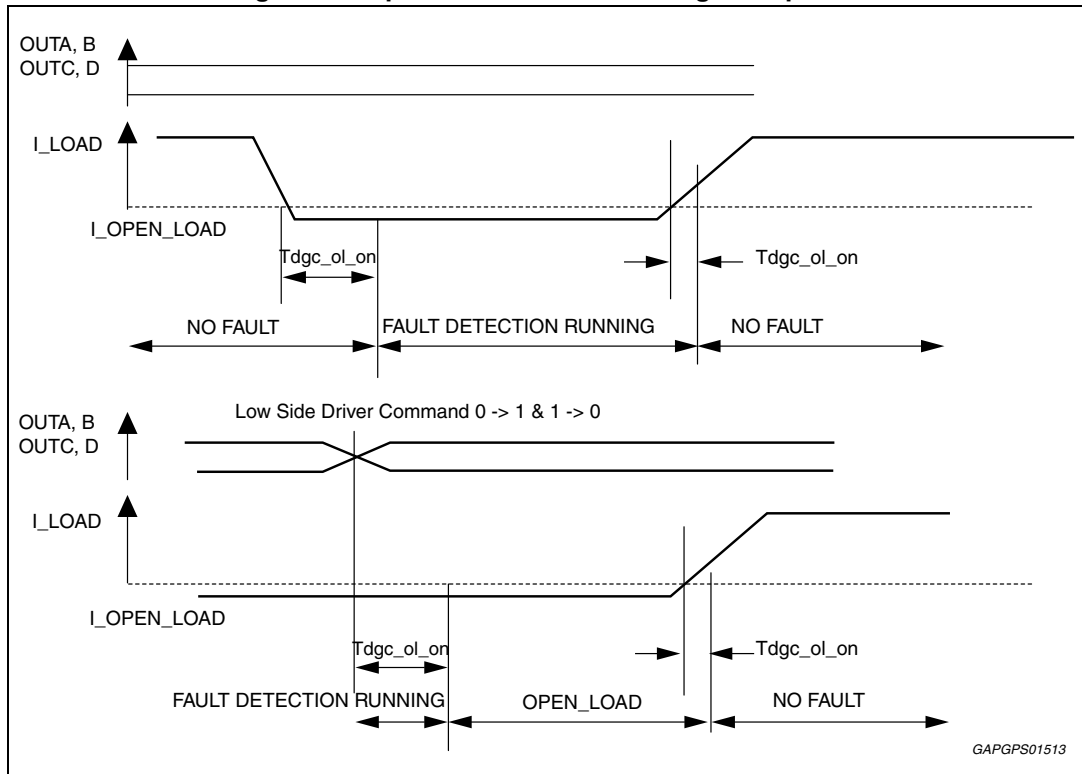

Figure 51. Open load detection during "on" phase

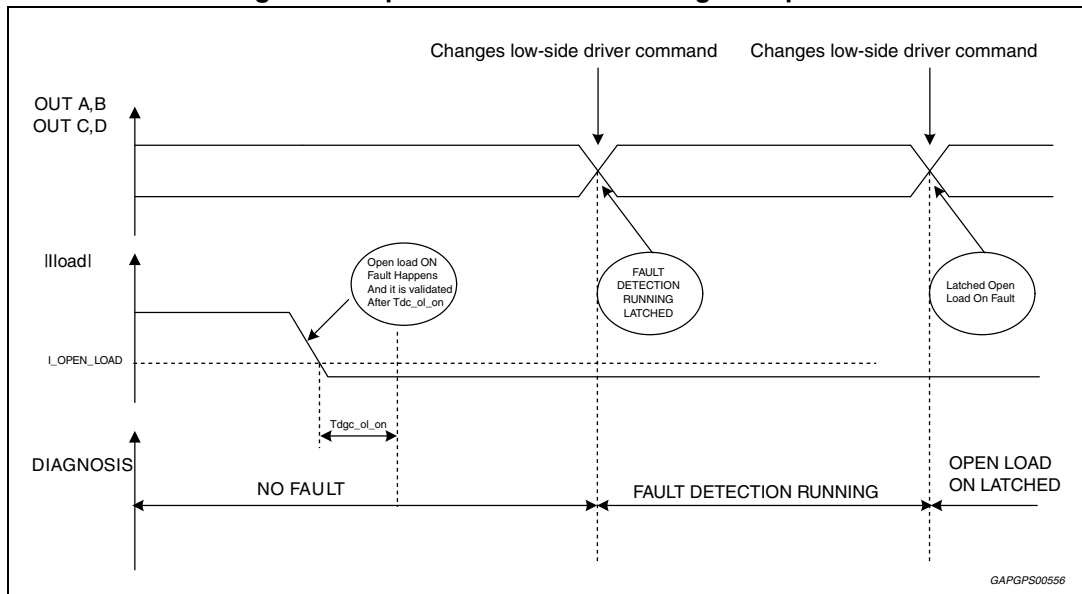

Figure 52. Short to GND detection during “on” phase

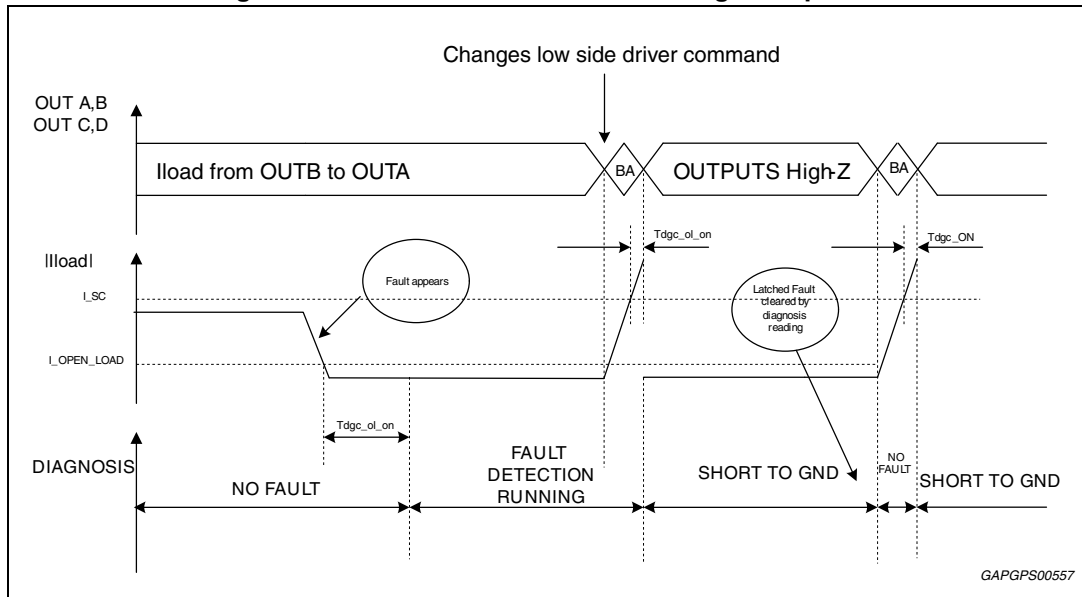

Table 34. Stepper configuration electrical characteristics

Pin	Symbol	Parameter	Test condition	Min	Typ	Max	Unit
OUT A to D	$V_{Outnorm}$	OUT(21,22), OUT(23,24), OUT(25,27), OUT(26,28) output voltage	OUT(21,22) short to OUT(23,24); OUT(25,27) short to OUT(26,28);	2.3	-	2.7	V
	H_{VTH}	Diagnostic high threshold	Driver in OFF condition	$V_{Outnorm} + 120mV$	-	3	V
	L_{VTH}	Diagnostic low threshold	Driver in OFF condition	1.9	-	$V_{Outnorm} - 200mV$	V
	I_{ovc}	Over current threshold	-	1	-	2.1	A
	I_{OPEN_LOAD}	Output open load threshold current	-	10	-	90	mA
	$I_{OUT_PD_A+B}$ or C+D	Output diagnostic pull down current OFF STATE	$V_{pin} = 5 V$	200	-	350	μA
	$I_{OUT_PU_A+B}$ or C+D	Output diagnostic pull up current OFF STATE	$V_{pin} = 1.5 V$	50	-	150	μA
	R_{openl}	Open load resistor threshold	Application note	150	-	-	k Ω
	T_{dgc_ON}	Degitch filter time in ON condition	Test by scan	-25%	10	+25%	μs
	T_{dgc_OFF}	-	Test by scan	-25%	125	+25%	μs
	$T_{dgc_ol_on}$	-	Test by scan	-25%	20	+25%	μs

Table 34. Stepper configuration electrical characteristics (continued)

Pin	Symbol	Parameter	Test condition	Min	Typ	Max	Unit
OUT21...28	Tmask_step	-	Test by scan	-25%	1	+25%	ms
	Tsettle	-	For information only; No tested	100	-	-	ms
	T_PWM	Operating frequency	For information only; No tested	50	-	-	μs

6.11.4 Diagnosis of CPS OUTA, B, C, D when configured as single low side power stages

For the low side the diagnosis is the same as LSd (see [Section 6.9](#)).

Each channel locally detects and writes its own fault or no-fault condition (codified on 2 bit according to [Table 27: Fault encoding condition](#)).

- Short circuit to battery or overcurrent for all the outputs during ON condition.
- Open load or short to GND during OFF condition.

The faults are latched and reset at every Read Diag operation.

In OFF condition the first fault detected is latched and can be overwritten only by the ON condition fault.

Electrical and diagnosis characteristics of OUTA, B, C, D when configured as single power stages

Same parameter and diagnosis function as LSd.

Table 35. Electrical and diagnosis characteristics of OUTA, B, C, D when configured as single power stages

Pin	Symbol	Parameter	Test condition	Min	Typ	Max	Unit
OUTA, OUTB, OUTC, OUTD	$R_{DS-on\ LSd}$	Drain source resistance	$I_{load} = 0.6\text{ A}$	-	-	1.5	Ω
	$I_{OUT\ lk}$	Output leakage current	$V_{pin} = 13.5\text{ V}$	-	-	10	μA
	$V_{S/R}$	Voltage S/R On/off	$R = 21\ \Omega$, $C = 10\text{nF}$ From 80% to 30% of V_{OUT}	2	-	6	V/us
	$V_{S/R\ GateKill}$	Fast VR/S off when an OVC fault happens	Load: $8\ \Omega$, 10nF - from 80% to 30% of V_{OUT}	5	-	30	V/ μs
	$T_{Turn-On_LSd}$	Turn-on delay time	From command to 80% V_{OUT} Load: $21\ \Omega$, 10nF	-	-	6	μs
	$T_{Turn-Off_LSd}$	Turn-off delay time	From command to 30% V_{OUT} Load: $21\ \Omega$, 10nF	-	-	6	μs
	V_{cl}	Output clamping voltage	$I_{load} = 0.6\text{ A}$	46	48	50	V
	$PW_{clampSP}$	Clamp single pulse ATE test	$I_{load} = 0.6\text{ A}$; single pulse	-	-	15	mJ
	$PW_{clampRP}$	Clamp repetitive pulses Freq = 1 Hz (to be verified) Reliability Test	$T_c \leq 30\text{ }^\circ\text{C}$; $I_{OUT_n} \leq 0.45\text{ A}$ 1 Mio cycles	-	-	6.5	mJ
			$T_c \leq 80\text{ }^\circ\text{C}$; $I_{OUT_n} \leq 0.3\text{ A}$ 25 Mio cycle	-	-	6.5	
	$T_c \leq 100\text{ }^\circ\text{C}$; $I_{OUT_n} \leq 0.3\text{ A}$ 20 Mio cycle		-	-	6.5		
	$T_c \leq 130\text{ }^\circ\text{C}$; $I_{OUT_n} \leq 0.3\text{ A}$ 5 Mio cycle		-	-	5.5		
	Reverse voltage	Body diode reverse current voltage drop	$I = -0.6\text{ A}$	-0.5	-1	-1.1	V

Electrical characteristics of OUTA, B, C, D when configured as single power stages connected in parallel

When the low side drivers are connected in parallel (in pair) to obtain a low side driver with a lower resistance, OUTA with OUTB and OUTC with OUTD, for example the following parameters are valid:

Table 36. Electrical characteristics of OUTA, B, C, D when configured as single power stages connected in parallel

Pin	Symbol	Parameter	Test condition	Min	Typ	Max	Unit
OUTA, OUTB, OUTC, OUTD	I _{max}	Output current	Not tested	-	1.2	-	A
	R _{DS-on LSd}	Drain source resistance	I _{load} = 1.2 A	-	-	0.75	Ω
	I _{OUT_{lk}}	Output leakage current	(1)	-	-	10	μA
	V _{S/R}	Voltage S/R on/off		2	-	6	-
	T _{Turn-on}	Turn-on delay time		-	-	6	μs
	T _{Turn-off}	Turn-off delay time		-	-	6	μs
	I _{OVC}	Over current threshold		2	-	4.2	A
	PW _{clampSP}	Clamp single pulse		I _{load} = 1 A; single pulse ⁽¹⁾	-	-	25
	PW _{clampRP}	Clamp repetitive pulses	Reliability note: I _{load} = 0.6 A Freq = 10 Hz; 36 Mpulse (1000h)	-	-	12	mJ
	I _{OUT_PD}	Output diagnostic pull down current off state	V _{pin} = 5 V	50	-	110	μA
	I _{OUT_PU}	Output diagnostic pull up current off state	(1)	-210	-	-108	μA
	ΔV _{clamp}	Delta clamping voltage between low side to be parallelized		-250	-	+250	mV

1. Not to be tested, already covered by single low side measure and guaranteed by design.

(CPS) CONFIG_REG10

Table 37. CPS table single mode parallelism

Register bit	7	3	2	1	0	The table configuration will be active if confi_reg7-bit4 is configured at Zero (Default at 1) If not specified Output Drivers are set as single (not in parallel with any other) Over Current mask time increased to 8 μ s	Enable by	Diagnostic
4Low	0	1	0	0	0	OUT22 and OUT24 and OUT27 and OUT28 Low side Parallel	OUT24	OUT22
2 LSSingle + 2 LSPar	0	0	0	1	0	OT27 and OUT28 single + OUT22 and OUT24 parallel	OUT24	OUT22
2 LSPar + 2 LSPar	0	0	1	0	0	OT27 and OUT28 single + OUT22 and OUT24 parallel	OUT24, OUT27	OUT22, OUT27
3 LSPar	1	1	1	0	0	OUT24 and OUT27 and OUT28 parallel	OUT24	OUT24

There are three configurations of CONFIG_REG10 register which allow enabling HS drivers. These configurations shall be used by taking care of not switching on HS and LS drivers simultaneously on the same OUTx path. Note that for Parallel HS configurations, HS diagnostic current is doubled.

Table 38. Three configurations of CONFIG_REG10 register

7	6	5	4	3	2	1	0	These configurations allow enabling HS drivers and LS drivers in CPS mode	Enable by	Diagnostic
0	0	0	0	0	0	0	0	Single drivers can be enabled by sending related command	CMD_OUTx	OUTx
0	0	0	1	0	0	1	0	OUT25 and OUT26 parallel + OUT22 and OUT24 parallel + all others Single	OUT24,OUT25	OUT22
0	0	1	1	0	1	1	0	OUT21 and OUT23 parallel + OUT27 and OUT28 parallel + all others Single	OUT23, OUT27	OUT27

Note: When those four single Lside and four single Hside are configured as parallel configuration, for example 2 single Lside stage to 1 Lside stage or 4 single Lside stage to 1 Lside stage, the Rdsn could be 1/2 or 1/4 as one single stage, the over current threshold could be roughly double or 4 times as single stage, but the over current detected filter time will be increased to 2 times as single stage from 4 μ s typical to 8 μ s typical by L9779WD-SPI itself, because each single stage will switch on its own overcurrent threshold no matter the configuration for off stage diagnostic, all thresholds will be kept as single stage whatever the configuration of those 4 Lside/Hside.

6.12 ISO serial line (K-LINE)

Figure 53. ISO serial line (K-LINE) circuit

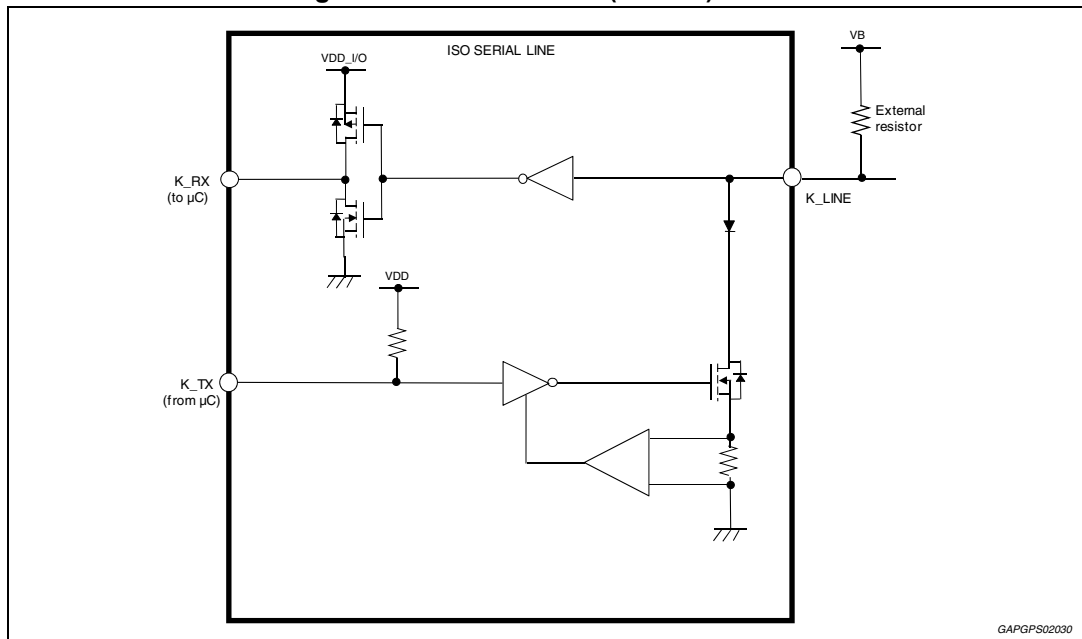

6.12.1 ISO serial line (K-LINE) functionality description

The ISO serial line is an interface containing one bidirectional line for communication between the μ P and an external diagnosis tester or antitheft device. In case of ground loss the outputs K_LINE get in high impedance state and can withstand a negative voltage up to -18 V. Short circuit to Vb protection is provided: if the K_LINE pin is shorted to battery the output is switched off after a delay of $t_{filter_K_LINE}$ and it is necessary an input change to turn on it again.

The negative transition at K_LINE pin can be driven with slew-rate limitation for optimizing the EMI behavior. This slew-rate limitation must be enabled via the ISO_SRC bit.

The K_TX signal is ignored (K_LINE pin to high level) until the RST pin is asserted.

KLIN can work up to 250kHz input frequency in typical application condition.

Table 39. ISO serial line (K-LINE) functionality electrical characteristic

Pin	Symbol	Parameter	Test condition	Min	Typ	Max	Unit
K_TX	V _{KTXL}	K_TX input low voltage	-	-0.3	-	1.1	V
	V _{KTXH}	K_TX input high voltage	-	2.3	-	VDD +0.3	V
	R _{TX_KPU}	TX_KLINE pull-up resistor	-	50	-	250	kΩ
	I _{TXsink}	Transmitter input sink current	K_LINE = 0, K_TX = High	-	-	5	μA
K_LINE	V _{KOUTL}	Transmitter output low voltage	I _{sink_K_LINE} = 35 mA, K_TX = Low	-1	-	1.5	V
	I _{KOS}	Transmitter short circuit current	K_LINE = VB, K_TX = Low	60	-	165	mA
	T _{filter_K_LINE}	Overcurrent filter time	Test by SCAN	7	10	13	μs
	I _{KREV}	Reverse battery or GND loss current	Key_on = VB = 0 V K_LINE = -18 V	-	-	10	mA
		Under voltage current	Key_on = High, K_TX = Low, VB = 13.5 V, K_LINE = -1V	-	-	1	mA
	V _{KH}	Receiver input hysteresis	-	0.08*VB	-	0.3*VB	V
	V _{KINH}	Receiver input high voltage	-	0.7* VB	-	VB	V
	V _{KINL}	Receiver input low voltage	-	-1	-	0.35*VB	V
	V _{K_SR}	K_line voltage slew - rate	From off to on: VB = 13.5 V, R _{ext} = 510 Ω C = 10 nF to GND	5.3	-	8.8	V/μs
			From on to off	Depends on external RC load		-	
T _{FT}	Transmitter fall time	CK_LINE = 10 nF, RK_LINE = 510 Ω	-	-	10	μs	
K_RX	V _{KRXL}	K_RX output low voltage	VDD_IO = 5 V or 3.3 V I _{sink} = 2 mA	-	-	0.5	V
	V _{KRXH}	K_RX output high voltage	VDD_IO = 5 V or 3.3 V I _{source} = 2 mA	VDD_IO -0.5	-	-	V
	T _{rK}	K_RX rise time	from 10% to 90% With 20 pF capacitive load	-	-	2	μs
	T _{fK}	K_RX fall time	from 90% to 10% 20 pF capacitive load	-	-	2	μs
K_TX, K_LINE	Tp_HLT	Transmitter turn-on delay time	CK_LINE = 10 nF, RK_LINE = 510 Ω	-	-	5	μs

6.13 CAN transceiver

Figure 56. CAN transceiver diagram

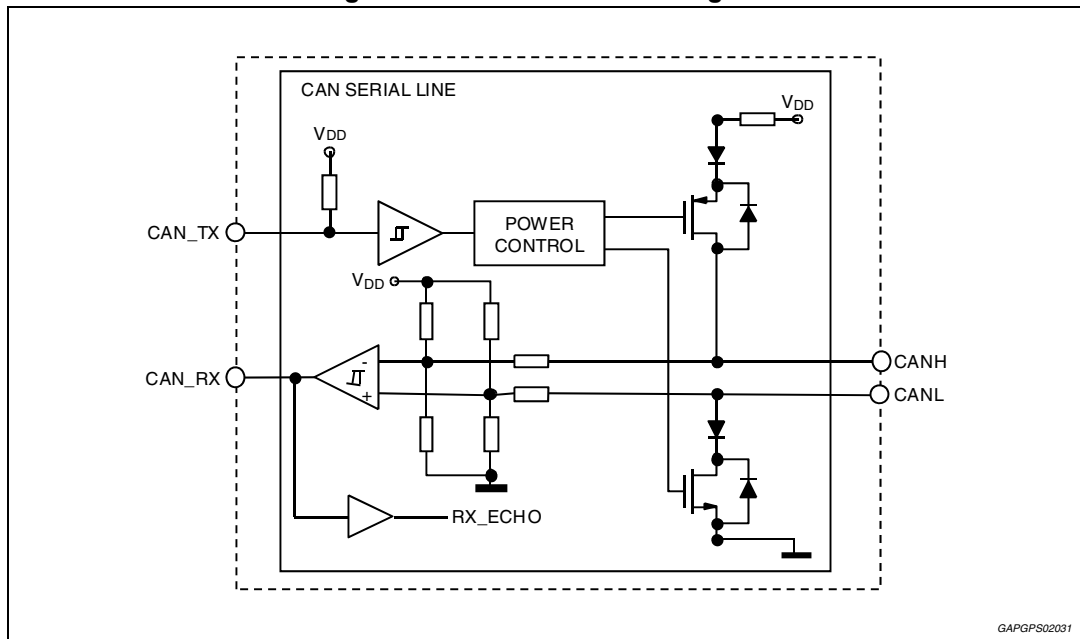

6.13.1 CAN transceiver functionality description

The CAN bus transceiver allows the connection with a microcontroller through a high speed CAN bus with transmission rates up to 1Mbit/s. The transceiver has one logic input pin (CAN_TX), one logic output pin (CAN_RX) and two input/output pins for the electrical connections to the two bus wires (CANH and CANL). The microcontroller sends data to the CAN_TX pin and it receives data from the CAN_RX pin.

In case of power loss (VB pin disconnected) or ground loss (GND pins disconnected), the transceiver doesn't disturb the communication of the remaining transceivers connected to the bus. If CANL is shorted to ground, the transceiver is able to operate with reduced EMI/RFI performances.

TX or RX=0 means Dominant state of CANH and CANL; TX or RX=1 means Recessive state compliant to ISO11898-2.

- Speed communication up to 1Mbit/s
- Function range from +40 V to -18 V DC at CAN pins
- GND disconnection fail safe at module level
- GND shift operation at system level
- ESD: Immunity against automotive transients per ISO7637 specification
- Matched output slopes and propagation delay.

The CAN_TX signal is ignored (CAN to recessive state) until the RST pin is asserted.

CAN error handling

The L9779WD-SPI provides the following 4 error handling features that are realized in different stand alone CAN transceivers / micro controllers to switch the application back to normal operation mode.

If one of the below fault happens the status bit CAN_ERROR is set.

The error handling features can be disabled through the CAN_ERR_DIS bit.

1. Dominant CAN_TX time out
 If CAN_TX is in dominant state (low) for $t > t_{dom(TxD)}$ the transmitter will be disabled, status bit will be latched and can be read and cleared by SPI. The transmitter remains disabled until the status register is cleared.
2. CAN permanent recessive
 If CAN_TX changes to dominant (low) state but CAN bus (CAN_RX pin) does not follow for 4 times, the transmitter will be disabled, status bit will be latched and can be read and cleared by SPI. The transmitter remains disabled until the status register is cleared.
3. CAN permanent dominant
 If the CAN bus state is dominant (low) for $t > t_{CAN}$ a permanent dominant status will be detected. The status bit will be latched and can be read and cleared by SPI. The transmitter will not be disabled.
4. CAN_RX permanent recessive
 If CAN_RX pin is clamped to recessive (high) state, the controller is not able to recognize a bus dominant state and could start messages at any time, which results in disturbing the overall bus communication.
 Therefore, if RX_ECHO does not follow CAN_TX for 4 times the transmitter will be disabled. The status bit will be latched and can be read and optionally cleared by SPI. The transmitter remains disabled until the status register is cleared.

CAN transceiver electrical characteristics

Table 40. CAN transceiver electrical characteristics

Pin	Symbol	Description	Test conditions	Min	Typ	Max	Unit
CAN_TX	V _{TX_CANLOW}	Input voltage dominant level	Active mode	-0.3	-	1.1	V
	V _{TX_CANHIGH}	Input voltage recessive level	Active mode	2.3	-	VDD +0.3	V
	V _{TX_CANHYS}	V _{TX_CANHIGH} - V _{TX_CANLOW}	Active mode	0.25	0.5	-	V
	R _{TX_CANPU}	CAN_TX pull up resistor	Active Mode	50	-	250	kΩ
CAN_RX	V _{RX_CANLOW}	Output voltage dominant level	Active mode, VDD_IO = 5 V or 3.3 V, 2 mA	-	-	0.5	V
	V _{RX_CANHIGH}	Output voltage recessive level		VDD_IO -0.5	-	-	V

Table 40. CAN transceiver electrical characteristics (continued)

Pin	Symbol	Description	Test conditions	Min	Typ	Max	Unit
CAN_H CAN_L	$V_{CANHdom}$	CANH voltage level in dominant state	Active mode; $V_{TXCAN} = V_{TXCANLOW}$; $R_L = 60 \Omega$	2.75	-	4.5	V
	$V_{CANLdom}$	CANL voltage level in dominant state		0.5	-	2.25	V
	$V_{DIFF,domOUT}$	Differential output voltage in dominant state: $V_{CANHdom} - V_{CANLdom}$		1.5	-	3	V
	V_{CM}	Driver symmetry: $V_{CANHdom} + V_{CANLdom}$	$R_L = 60 \Omega$; $C_{SPLIT} = 4.7 \text{ nF}$;	0.9* V_{CANSUP}	V_{CANSUP}	1.1* V_{CANSUP}	V
	$V_{CANHrec}$	CANH voltage level in recessive state	$V_{TX_CAN} = V_{TX_CANHIGH}$; No load	2	2.5	3	V
	$V_{CANLrec}$	CANL voltage level in recessive state		2	2.5	3	V
	$V_{DIFF,recOUT}$	Differential output voltage in recessive state: $V_{CANHrec} - V_{CANLrec}$		-50	-	50	mV
	$V_{CANHL,CM}$	Common mode bus voltage	Application info: Measured with respect to the ground of each CAN node	-12	-	+12	V
	$I_{OCANH,dom}$	CANH output current in dominant state	Active mode; $V_{TX_CAN} = V_{TX_CANLOW}$; $V_{CANH} = 0 \text{ V}$	-100	-75	-45	mA
	$I_{OCANL,dom}$	CANL output current in dominant state	Active mode; $V_{TX_CAN} = V_{TX_CANLOW}$; $V_{CANL} = 5 \text{ V}$	45	75	100	mA
	$I_{Leakage}$	Input leakage current	Unpowered device; $V_{BUS} = 5 \text{ V}$	0	-	250	μA
	R_{in}	Internal resistance	Active mode $V_{TX_CAN} = V_{TX_CANHIGH}$; No load	25	-	45	k Ω
	$R_{in,diff}$	Differential internal resistance	Active mode & STBY mode; $V_{TX_CAN} = V_{TX_CANHIGH}$; No load	50	-	85	k Ω
	C_{in}	Internal capacitance	Guaranteed by design	-	20	-	pF
	$C_{in,diff}$	Differential internal capacitance	Guaranteed by design	-	10	-	pF
V_{THdom}	Differential receiver threshold voltage recessive to dominant state	Active mode	-	-	0.9	V	

Table 40. CAN transceiver electrical characteristics (continued)

Pin	Symbol	Description	Test conditions	Min	Typ	Max	Unit
CAN_H CAN_L	V_{THrec}	Differential receiver threshold voltage dominant to recessive state	Active mode	0.5	-	-	V
	SR_H	CANH slew rate between 10% and 90%	-	5	-	35	V/ μ s
	SR_L	CANL slew rate between 10% and 90%	-	5	-	35	V/ μ s
	DIFF_SR	Slew rate difference between CANH and CANL	-	-	-	60	%
	SR_{VDIFF}	Slew rate of $V_{diff} = V_{CANH} - V_{CANL}$	-	12	-	100	V/ μ s
	V_{THhys}	$V_{THdom} - V_{THrec}$ hysteresis	-	25	-	50	mV

Table 41. CAN transceiver timing characteristics

Symbol	Description	Test conditions	Min	Typ	Max	Unit
$t_{TXpd,hl}$	Propagation delay TX_CAN to RX_CAN (High to Low) Guaranteed by design.	Active mode; 50% V_{TX_CAN} to 50% V_{RX_CAN} ; $C_L = 100$ pF; $C_{RX_CAN} = 15$ pF; $R_L = 60$ Ω ;	0	-	255	ns
		$C_{RX_CAN} = 100$ pF @ T_{room} and T_{cold}	-	-	265	ns
		$C_{RX_CAN} = 100$ pF @ T_{hot}	-	-	275	ns
$t_{TXpd,lh}$	Propagation delay TX_CAN to RX_CAN (Low to High) Guaranteed by design.	Active mode; 50% V_{TX_CAN} to 50% V_{RX_CAN} ; $C_L = 100$ pF; $C_{RX_CAN} = 15$ pF; $R_L = 60$ Ω ;	0	-	255	ns
		$C_{RX_CAN} = 100$ pF @ T_{room} and T_{cold}	-	-	265	ns
		$C_{RX_CAN} = 100$ pF @ T_{hot}	-	-	275	ns
$t_{dom(TX_CAN)}$	TX_CAN dominant time-out	Tested by scan	525	700	875	μ s
t_{CAN}	CAN permanent dominant time-out	Tested by scan	-	700	-	μ s

Figure 57. CAN transceiver switching waveforms

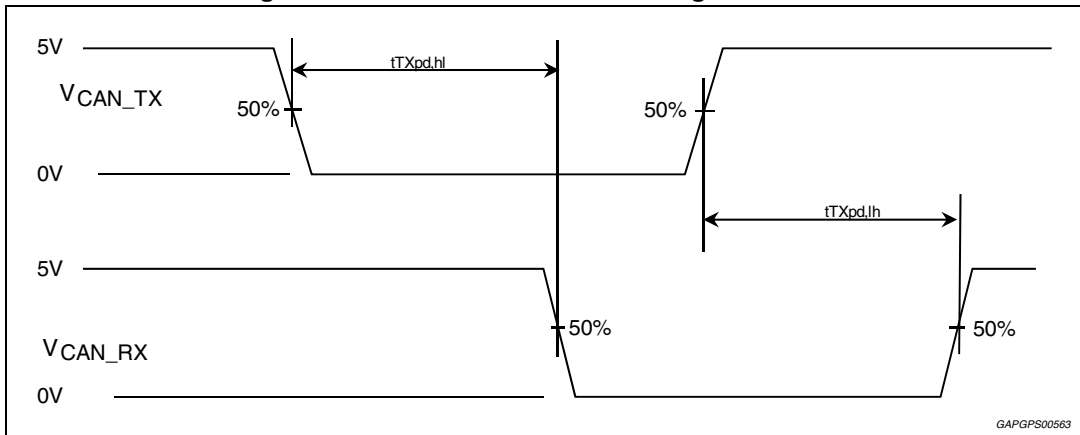
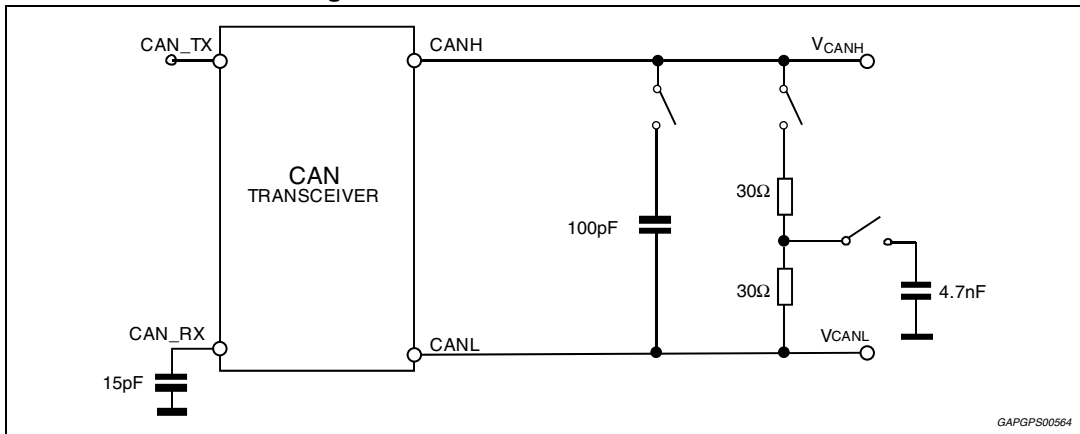
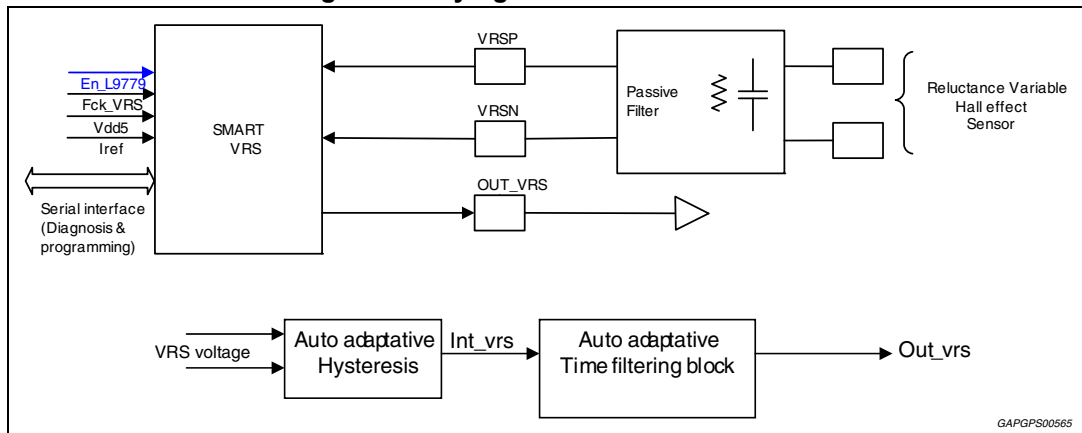

Figure 58. CAN transceiver test circuit



6.14 Flying wheel interface function

Figure 59. Flying wheel interface circuit



6.14.1 Flying wheel interface functionality description

The flying wheel interface is an interface between the microprocessor and the flying wheel sensor: it handles signals coming from magnetic pick-up sensor or Hall Effect sensor and feeds the digital signal to Microcontroller that extracts flying wheel rotational position, angular speed and acceleration.

This circuit implements an auto adaptive hysteresis and filter time algorithm that can be configured via SPI using VRS_mode bit.

If the auto adaptive hysteresis is OFF the hysteresis value can be selected using VRS_Hyst bit.

If fault is present (OL / SC GND / SC VB) the functionality is not guaranteed.

6.14.2 Auto-adaptive sensor filter

Two main VRS configuration sets are available for VRS, by means of CONFIG_REG1 register: fully adaptive VRS mode (default) and limited adaptive VRS mode.

Auto-adaptive hysteresis (fully adaptive mode)

When enabled the auto adaptive hysteresis works as described below.

Input signals difference is obtained through a full differential amplifier; its output, DV signal, is fed to peak detection circuit and then to A/D converter implemented with 4 voltage comparators (5 levels) (Pvi).

Output of A/D is sent to Logic block ([Table 43: Hysteresis threshold precision](#)) that implements correlation function between Peak voltage and hysteresis value; hysteresis value is used by square filtering circuit which conditions DV signal.

Figure 60. Auto adaptive hysteresis diagram

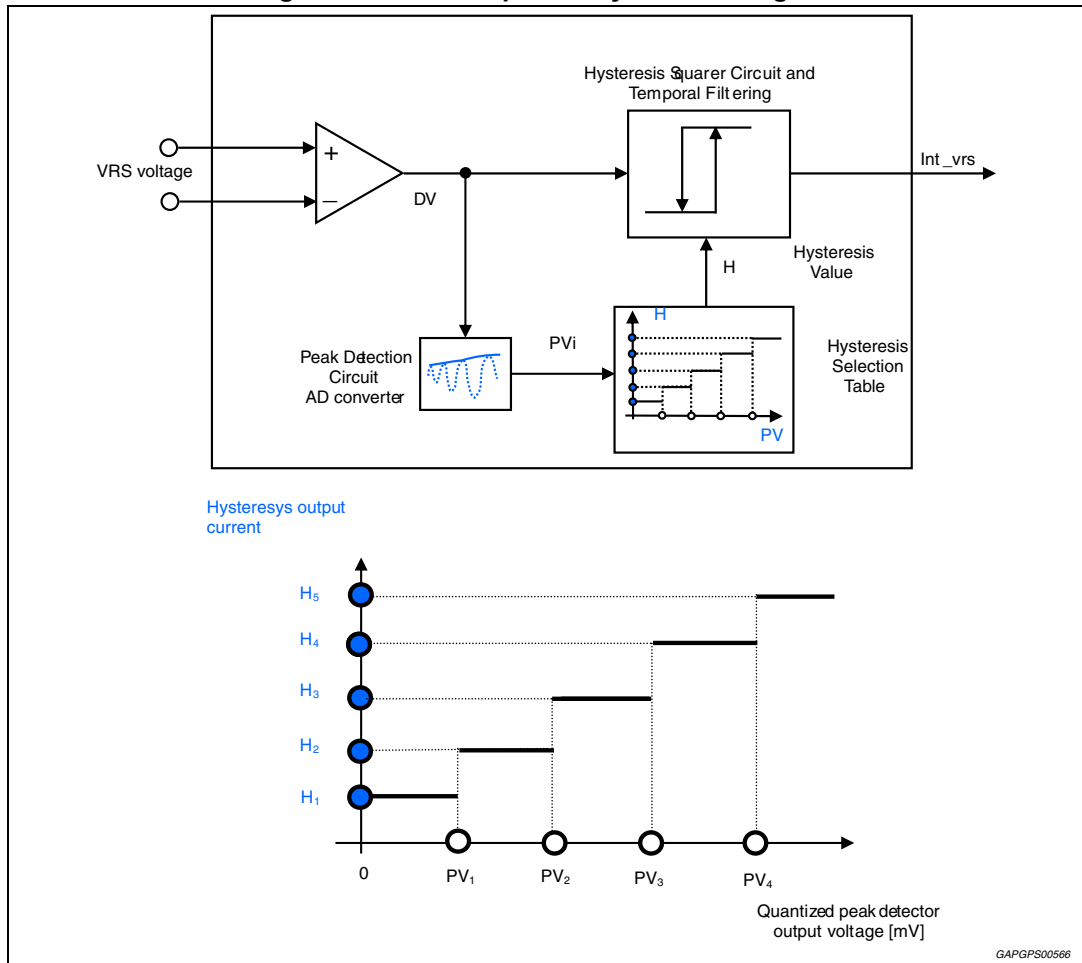

Figure 61. VRS interface block diagram

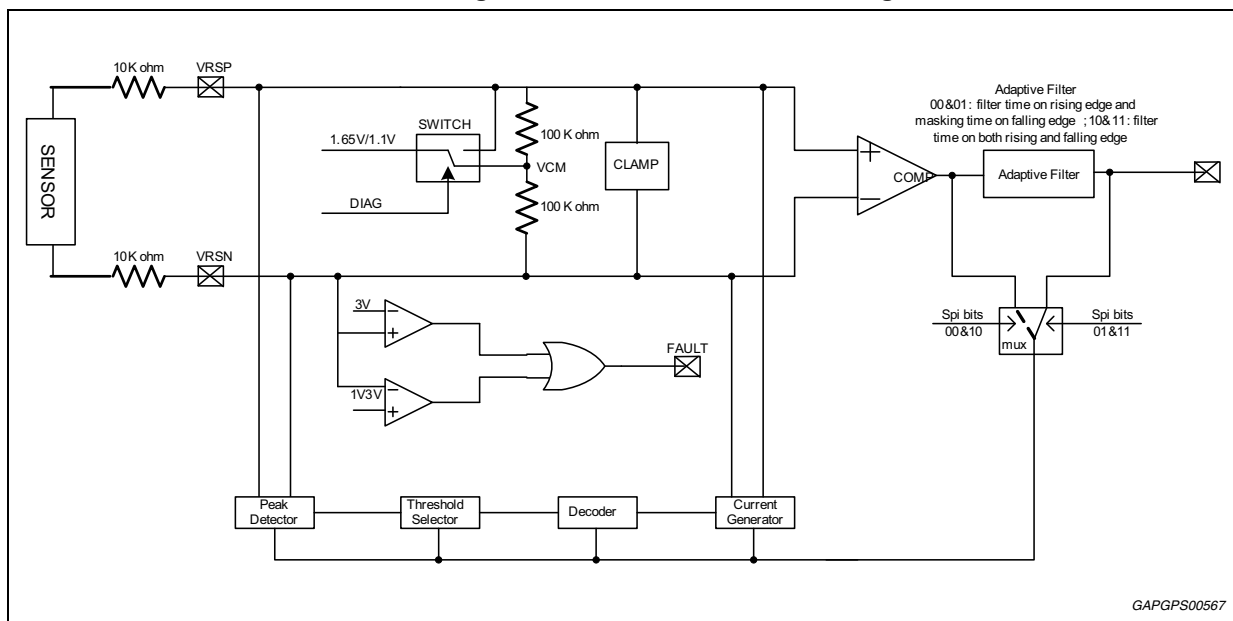

Table 42. Pick voltage detector precision

Pick voltage [PV]	Min	Typ	Max	Unit
PV1	600	930	1300	mV
PV2	1200	1600	1950	mV
PV3	1990	2300	2600	mV
PV4	2660	3000	3380	mV

Table 43. Hysteresis threshold precision

Hysteresis current [H]	Value			Unit	Correspondent value on 20 kΩ ext. resistor	Unit
	Min	Typ	Max		Typ	
HI1	3	5	7	μA	100	mV
HI2	7	10	13.5	μA	200	mV
HI3	12.8	17	23	μA	347	mV
HI4	23	32	41	μA	644	mV
HI5	35	51	65	μA	1020	mV

Note: For a single IC, there is no overlap of parameters PVX (PV1<PV2<PV3<PV4) and HIX(HI1<HI2<HI3<HI4<HI5), which are guaranteed by design

Auto-adaptative time filter (fully adaptive mode)

This characteristic is useful to set the best internal filter time depending on the input signal frequency.

Tfilter time depends on duration of the previous period Tn according to the following formula:

$$T_{filter(n+1)} = 1/32 * T_n \text{ if } Int_vrs > T_{filter(n)}$$

The filtering time purpose is filtering very short spikes.

The digital filtering time is applied to internal squared signal (int_vrs), obtained by Voltage comparators.

The output of time filtering block is out_vrs signal.

The filtering time Tfilter is applied to int_vrs signal in two different ways:

- Rising edge: if int_vrs high level lasts less than Tfilter out_vrs is not set to high level
In absence of any spikes during input signal rising edge out_vrs signal is expected with a delay of Tfilter time
- Falling edge: the falling edge of int_vrs is not delayed through time filtering block: after falling edge for a time Tfilter any other transition on int_vrs signal is ignored.

Tmaxfilter = 200 μs typ.

Tmin filter = 4 μs typ.

The default value after reset is Tmaxfilter.

The Tfilter function is reset by the enable of FLYING WHEEL function.

Figure 62. Auto-adaptive time filter (rising edge)

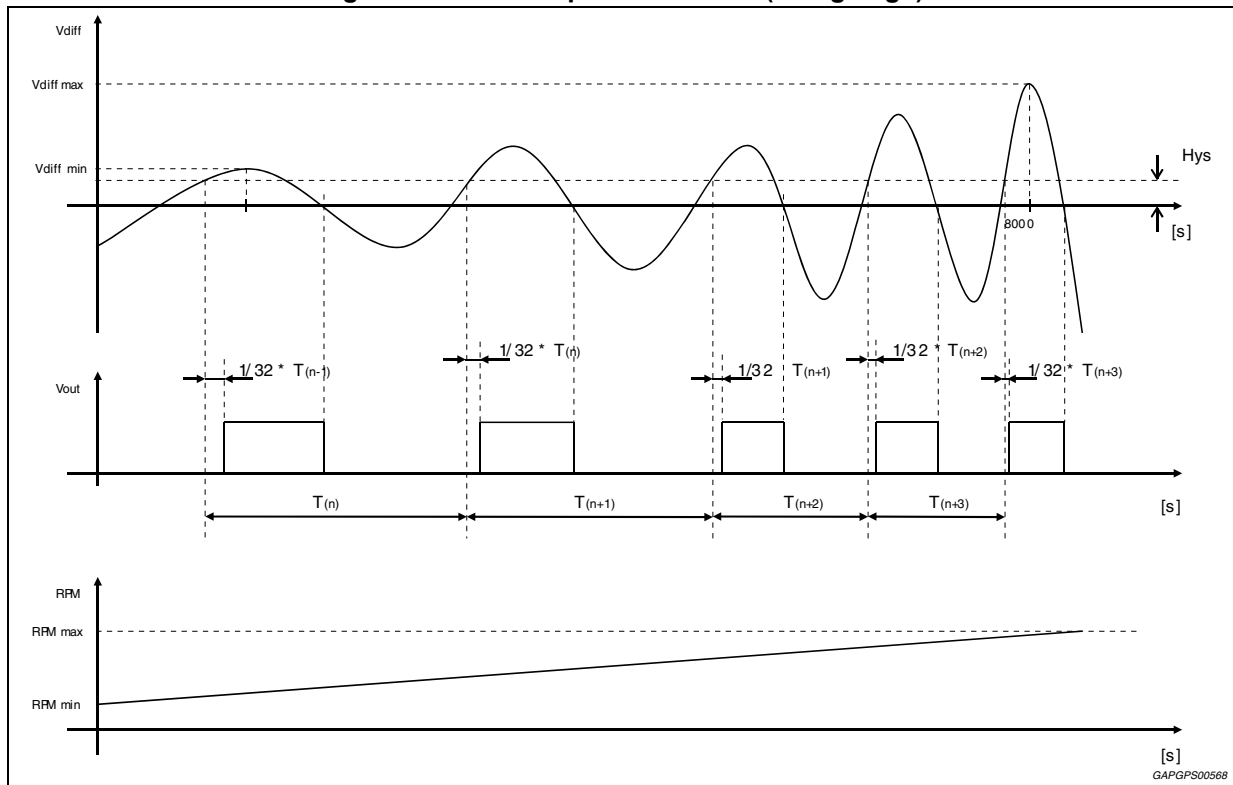
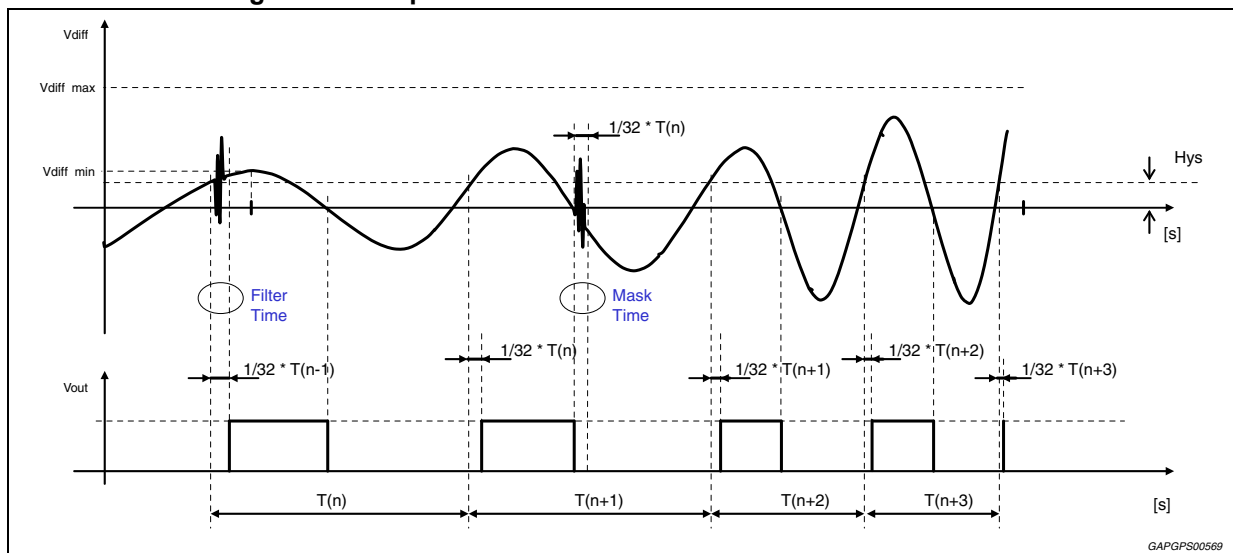

Figure 63. Adaptive filter function when the SPI bit are 00 or 01



Software option configuration requirement for VRS function:

- By SPI command it is possible to configure different options of the VRS function:
- The hysteresis changing is driven by a feedback signal coming from COMP output OR from adaptive filter
 - The adaptive filter can be either on the rising edge or on both edges of the VRS output.

Table 44. SPI command possible configuration of different option of VRS function

SPI Bit	00	01	10	11 ⁽¹⁾
Function	Feed back from COMP output. VRS input signal from low to high, add $1/32 * T_n$ filter time. VRS output from high to low with $1/32 * T_n$ masking time.	Feed back from after adaptive filter block instead of from COMP output (specifically as shown in Figure 64) VRS output signal from low to high, add $1/32 * T_n$ filter tune. VRS output from high to low with $1/32 * T_n$ masking time.	VRS input signal from high to low, add $1/32 * T_n$ filter time. VRS output from high to low with $1/32 * T_n$ filter time.	Realize 01 and 10 functions Feed back from after adaptive filter block instead of from COMP output. VRS output signal from low to high, add $1/32 * T_n$ filter time. VRS output from high to low with $1/32 * T_n$ filter time. Feed back from after adaptive filter block instead of from COM output. VRS output signal from low to high, add $1/32 * T_n$ filter time. VRS output from high to low with $1/32 * T_n$ filter time.

1. If SPI CONFIG_REG7-bit4 is set (High) VRS filter time is fixed to $4 \mu s \pm 1.25 \mu s$.

Figure 64. Adaptive Filter Function when the SPI bit are 10 or 11

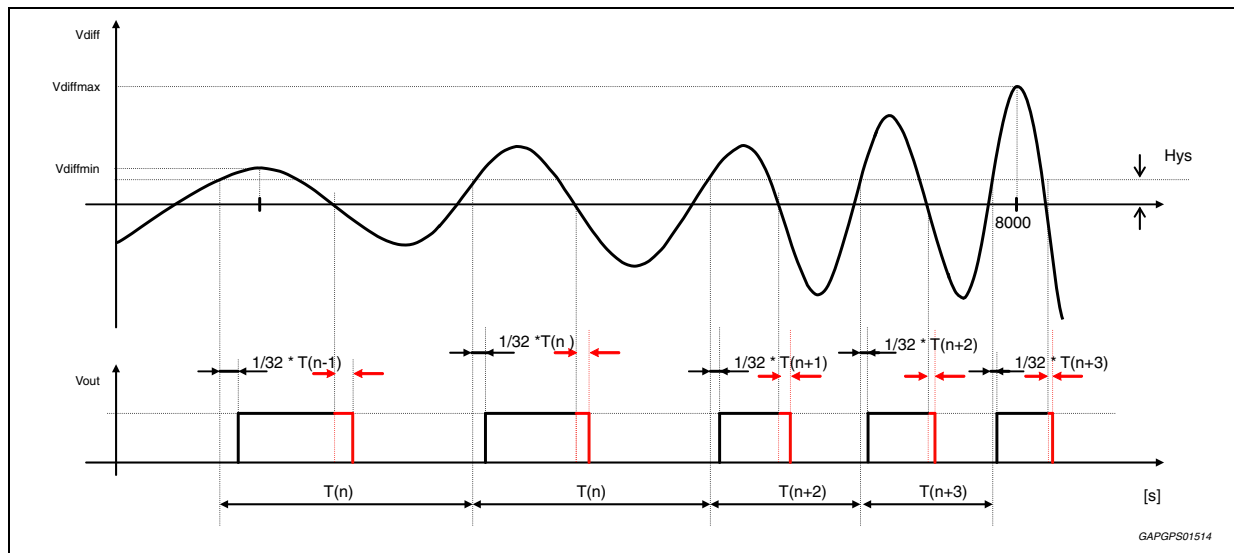

Limited adaptive mode

Auto time adaptive filter is fixed to $4 \mu s$ (typical).

Auto amplitude adaptive filter is limited to a minimum hysteresis as set by related VRS register.

Note that in case the VRS input amplitude is persistently lower than the minimum hysteresis setting, VRS output deadlock can be removed by setting CONFIG_REG5 bit5 to 1, which forces the hysteresis to 5 μ A. This procedure is not glitch free. Once a new minimum hysteresis value has been set, CONFIG_REG5 bit5 must return to 0.

VRS diagnostic is not available when limited adaptive mode is selected.

6.14.3 Application circuits

Figure 65. Variable reluctance sensor

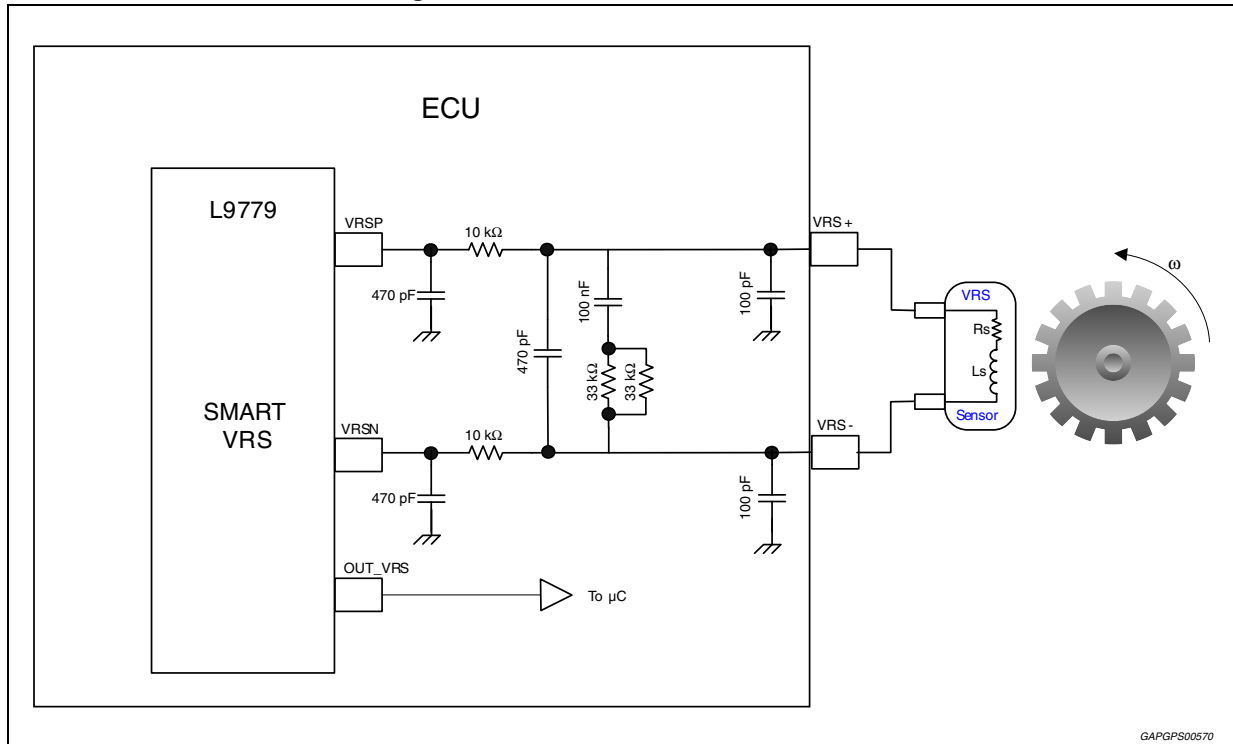

GAPGPS00570

Figure 66. VRs typical characteristics

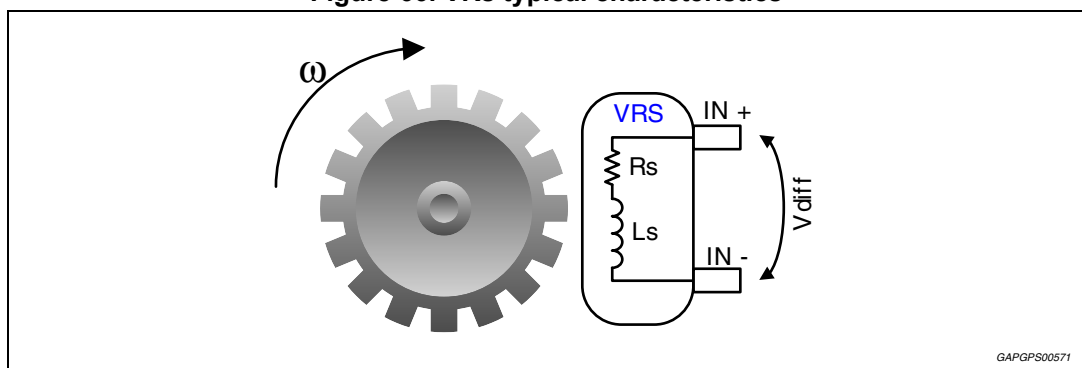

GAPGPS00571

Table 45. VRs typical characteristics

Symbol	Parameter	Min	Typ	Max	Unit
Rs	Sensor resistance	300	600	1000	Ω
Ls	Sensor inductor	-	250	-	mH
Vdiff	Sensor output voltage	-200	-	+200	V
Tout	Output period	5000	-	100	μ s

Figure 67. Hall effect sensor configuration 1

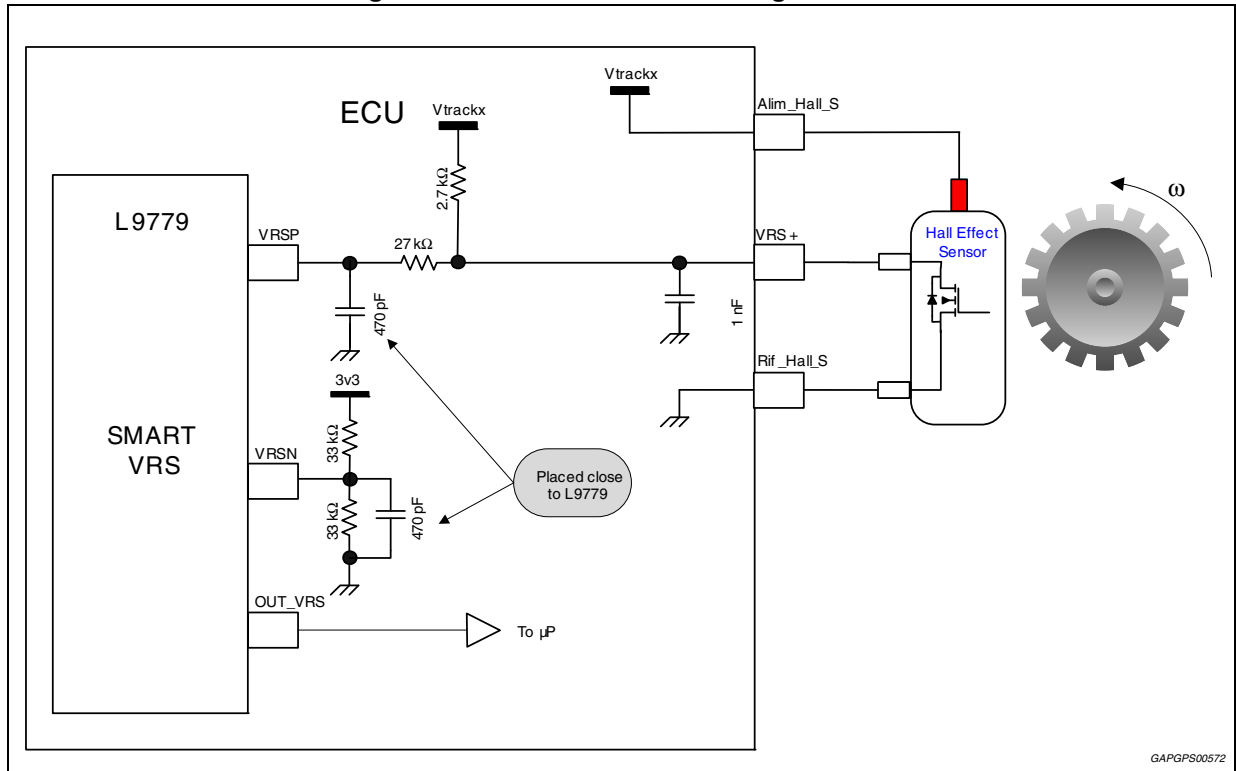

6.14.4 Diagnosis test

After the request of diagnosis by SPI, the diagnosis routine tests the sensor presence or vacancy and the short circuit to GND or Vbat. When the system is in diagnosis status the flying wheel interface function doesn't operate. The diagnosis procedure has an operation time of about min 5ms due to the external transient

The result of diagnosis routine is valid only if the engine is switched off and if the sensor is a variable reluctance sensor.

In the last operation of the diagnosis protocol writes the diagnosis result in VRSdiag bit and writes the operative status in VRSstatus bit. If a new request is sent the new value is overwritten.

Figure 69. Diagnosis test diagram

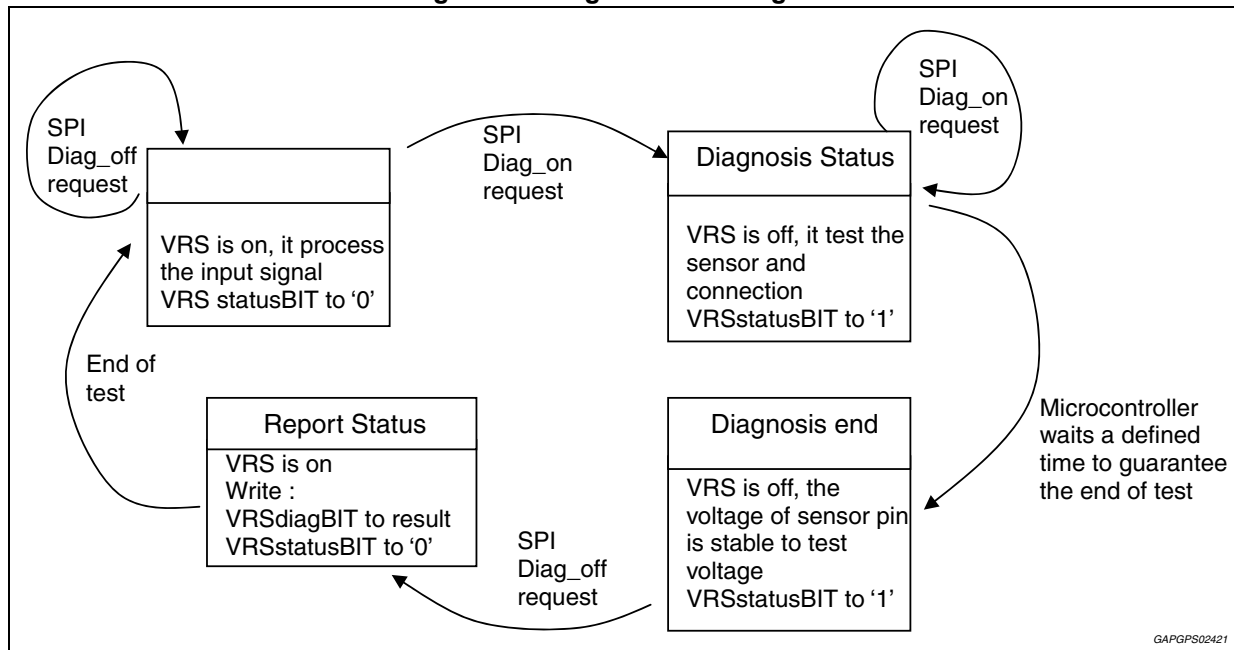

Table 46. Diagnosis test electrical characteristics

Pin	Symbol	Parameter	Test condition	Min	Typ	Max	Unit
VrsP VrsM	V_{iThL}	Input high-to-low differential threshold voltage	-	-50	0	50	mV
	V_{CM}	Common mode operating range	Not to be tested. It is an application note.	0	1.65	3	V
	V_{clpH}	Input high clamping voltage	$ VRS_INP = VRS_INM = 20\text{ mA}$	3.3 -0.3	-	3.3 +0.3	V
	V_{clpL}	Input low clamping voltage	$ VRS_INP = VRS_INM = 20\text{ mA}$	-1.5	-	-0.3	V
	$V_{openload}$	Output open load voltage	$VRS_INP = VRS_INM$ $V_{openload}$ Mode R enabled	1.5	(3.3) /2	1.8	V

Table 46. Diagnosis test electrical characteristics (continued)

Pin	Symbol	Parameter	Test condition	Min	Typ	Max	Unit	
VrsP	I_{bvrsp}	Input bias current Vrsp	VRS_INP = Vopenload Mode R enabled	-	-	2	μ A	
VrsM	I_{bvrsM}	Input bias current V _{rsm}	VRS_INM = Vopenload Mode R enabled	-	-	2	μ A	
Out_ Vrs	V_{OL}	Output low voltage	VDD_IO = 5 V or 3.3 V Isink current = 2 mA	-	-	0.5	V	
	V_{OH}	Output high voltage	VDD_IO = 5 V or 3.3 V Isource current = 2 mA	VDD_IO -0.5	-	-	V	
	I_{lk_outvrs}	Input leakage current to GND	-	-	-	-	1	μ A
		Input leakage current to VDD_IO	-	-	-	-	1	μ A
	$T_{d_on_outvrs}$	Delay on falling edge	Test Ext cap = 300pF	-	-	1	μ s	
	$T_{d_off_outvrs}$	Delay on rising edge	Input signal Tperiod = 4 ms	-	-	150	μ s	
	$T_{r_Out_vrs}$	MRX rise time	Test Ext cap = 300pF	-	-	150	ns	
$T_{f_Out_vrs}$	MRX fall time	Test Ext cap = 300pF	-	-	150	ns		
VrsP VrsM	$V_{outdiag}$	Output diag voltage	Vrs_INP = open; diag mode	0,9	(3.3)/3	1.3	V	
	$I_{outdiag}$	Output diag Current	Vrs_INP = open; Vrs_INM = GND; diag mode	50	65	80	μ A	
	V_{outsh} $V_{bdiag\ th}$	Output Short- circuit range to VBAT Open Load threshold	Vrs_INP = open; Vrs_INM = Vramp; diag mode	2,8	3	3,2	V	
	$V_{outsh\ gnd\ diag\ th}$	Output Short-to GND range threshold	Vrs_INP = open; Vrs_INM = Vramp; diag mode	1.1	1.3	1.5	V	

Note: When VrsP and VrsM are both in input high clamping condition, the clamp voltage of VrsP is 30mV(typical) higher than VrsM.

6.15 Monitoring module (watchdog)

Table 47. WDA_INT electrical characteristics

Pin	Symbol	Parameter	Test condition	Min	Typ	Max	Unit
WDA_INT	V _{WDA_low}	Output low voltage	3.5 V < VDD5 I _{WDA} < 4 mA	-	-	0.4	V
			2.2 V < VDD5 < 3.5V I _{WDA} < 1 mA	-	-	0.4	V
	I _{WDA}	Input leakage current	-	-	-	1	μA
	V _{WDA_in_low}	Input voltage low level	-	-0.3	-	1.1	V
	V _{WDA_in_high}	Input voltage high level	-	2.3	-	VDD _{IO} +0.3	V
	V _{WDA_in_hys}	Input voltage hysteresis	-	300	-	800	mV
	R _{pullup}	Internal pull-up resistor	-	50	-	150	kΩ
	f _{CLK1}	WDA clock CLK1	-	-5%	64	5%	kHz

6.15.1 WDA - Watchdog (algorithmic)

Basic feature

Via SPI bus a WDA "question" must be read from a SPI register. A correct response must be written back via SPI in a well defined timing. If response or timing is not correct, then the WDA error counter EC is increased. If the error counter is increased to values greater than 4, some output functions are shut off. If the error counter reaches values greater than 7 (overflow), then a RST reset may be generated if this is previously configured via SPI.

On the other way round, with a RST event also the WDA output pin goes to low.

Note that after startup, reset or an overflow the initial value of the error counter is 6.

If WDA resets are enabled via SPI: The number of RST events generated by an error counter overflow is limited by the reset counter RST_CNT. If RST_CNT reaches the value of 7, then RST resets via WDA are no longer generated.

In case many WDA events occur during after-run power latch mode, the power latch mode is terminated by the AB1 counter: With each error counter overflow, the AB1 counter is increased. If it reaches a value greater than 7, then the after-run power latch mode is terminated.

6.15.2 Monitoring module - WDA Functionality

Figure 70. WDA block diagram

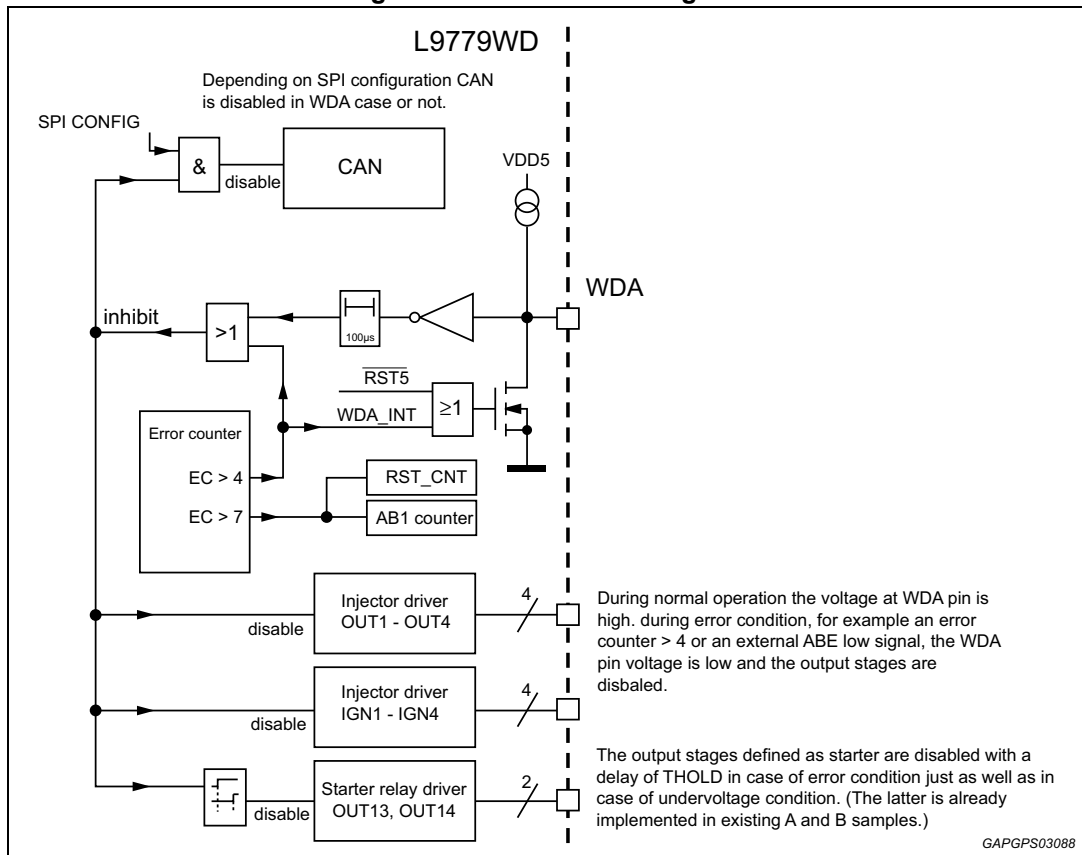

Each time the watchdog error counter is $EC > 7$ the AB1-counter AB1_CNT increases. When this counter is $AB1_CNT = 7$ and a further error occurs, the after-run will be terminated. The AB1-counter is not cleared when $EC < 7$. AB1-counter is cleared when $EC < 5$ and $\langle WDA_INT \rangle = '0'$, and is reset by RST_UV.

The monitoring module works independently of the controller functionality. The monitoring module generates various questions, which the controller must fetch and correctly respond to within a defined time window. The monitoring module checks whether the response is returned in a time window and if the response is fully correct.

The question is a 4-bit word. This 4-bit word can be fetched by the controller using a read access to register REQULO. The monitoring module also calculates the expected correct response, which is compared to the actual response from the controller.

The response is a 32-bit word consisting of the 4 bytes RESP_BYTE3, RESP_BYTE2, RESP_BYTE1 and RESP_BYTE0. The 4 bytes are sent to the monitoring module via SPI in the order RESP_BYTE3 - RESP_BYTE2 - RESP_BYTE1 - RESP_BYTE0 using four times the command WR_RESP - once for each answer byte.

The monitoring cycle is started by (the end of) writing of RESP_BYTE0 (least significant response byte) or by a write access to the RESPTIME register. The cycle starts with a variable wait time (response time, set by register RESPTIME), followed by a fixed time window. When a monitoring cycle ends (the end of the fixed time window has been reached) a new monitoring cycle is started automatically.

A correct response within the time window (at a response time > 0ms) decreases an ERROR COUNTER by one. An incorrect response, a response outside the time window or response time = 0ms leads to the incrementing of the ERROR COUNTER by one.

" within the time window" means that the end of writing the last answer byte - i.e. RESP_BYTE0 - falls into the fixed time window mentioned above (see picture below). Except the last answer byte, the previous answer bytes may also be written earlier than the beginning of the time window.

The question sequence is deterministic. A question will be repeated until it is answered correctly both in value and in time. Then the next question is placed in the sequence.

The ERROR COUNTER (EC) is a 3-bit counter. Various actions are activated depending on the value of the counter.

The result of the comparison of the controller response and the calculated correct response, as well as the next question, are available in the registers REQUIH/REQULO after receiving the µC response (LSB of RESP_BYTE0) and can be read by the controller.

Monitoring cycle

Figure 71. Monitoring cycle diagram

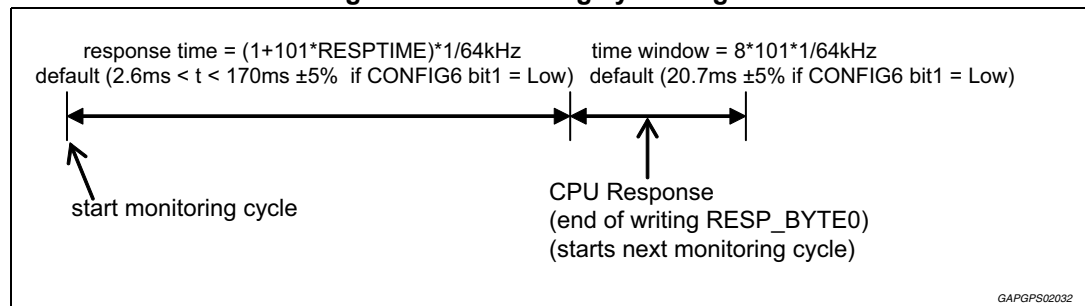

Generating questions

The generation of the 4-bit question (REQU [3-0]) is realized with a 4-bit counter and a 4-bit Markov chain. The 4-bit counter only changes into the next state during the sequencer-run when the previous question has been answered correctly in value and in time.

The Markov chain changes into the next state on the 1111b -> 0000b transition of the 4-bit counter if the previous question has been answered correctly in value and in time.

Neither the counter state nor the Markov chain states are changed by a sequencer-run because of a write-access to the RESPTIME register or the expiration of the time window.

The 4-bit counter and Markov chain are set to 0000b when RST_UV is active.

The singularity of the Markov chain is 0000b. To leave the singularity (after power-up, error state), the feedback path (M3 + M2 + M1 + M0) is realized. The "real" feedback logic of the Markov chain is the XOR gate (M3 XOR M2).

The following diagram shows the 4-bit Markov chain.

ERROR COUNTER (EC) and reactions, AB1 COUNTER (AB1_CNT) and generation of the monitoring module reset

Various actions are initiated for specific counter states of the ERROR COUNTER EC. The counter reset state is 6.

For ERROR COUNTER (EC) > 4, <WDA_INT> is set to '1', thus activating the open-drain output [WDA] that is low-active.

Table 48. Error counter

ERROR COUNTER	0 ... 4	5	6 ... 7	Over flow EC > 7
WDA_INT	low – i.e. '0'	high – i.e. '1'	high – i.e. '1'	high – i.e. '1'
[WDA]	inactive – i.e. '1'	active – i.e. '0'	active – i.e. '0'	active – i.e. '0'
AB1-COUNTER	0	unchanged	unchanged	incremented by 1
AB1	low – i.e. '0'	unchanged	unchanged	AB1_CNT < 7: low AB1_CNT 6 → 7: low AB1_CNT 7 → 7: high

Shutdown in an error state in "afterrun"

If the ERROR COUNTER reaches the value "7" and a further error occurs the AB1 COUNTER AB1_CNT is incremented by one during a sequencer-run.

The state "EC = 7 and a further error occurs" is also called ERROR COUNTER overflow ("EC" > 7).

If ERROR COUNTER > 4 AND a soft-reset is detected then the COUNTER AB1_CNT is also incremented by one. The counter AB1_CNT is a 3 bit counter.

Behaviour of AB1_CNT:

- asynchronous reset to "000" with RST_UV
- synchronous reset to "000" IF <WDA_INT> = LOW (EC < 5)
- IF (AB1_CNT < 7) AND ((sequencer-run AND "EC" > 7) OR soft-reset) THEN
AB1_CNT = AB1_CNT + 1
ELSE unchanged.

The counter cannot be decremented and can be only reset to "000" by an active RST_UV signal (asynchronous) or <WDA_INT> = '0' (synchronous).

The signal AB1 becomes active '1' when AB1_CNT = "111" and a further error is detected when the sequencer runs or when AB1_CNT = "111" and a soft-reset is detected.

In "afterrun", the active AB1 signal causes a shut-down of the main relay and the voltage regulators. This function ensures a secure shutdown of the system in an error state of the µC in "afterrun".

Behaviour of AB1:

- asynchronous reset to "0" with RST_UV
- synchronous reset to "0" IF <WDA_INT> = '0' (EC < 5)
- IF (AB1_CNT = 7) AND ((sequencer-run AND further error) OR soft-reset) THEN
AB1 = 1
ELSE unchanged.

Generation of a monitoring module reset

The monitoring module may cause a reset at the pin [RST] named "monitoring module reset" in conjunction with the internal signal WD_RST. The generation of a monitoring module reset depends on the state of the bit <INIT_WDR>.

<INIT_WDR> = '0' (reset state):

If <INIT_WDR> = '0', the signal <WD_RST> remains always inactive '0' and the monitoring module can never generate a reset. The error counter can only be decremented via correct responses. If <INIT_WDR> = '0' the state of the reset counter <RST_CNT> remains unchanged when an ERROR COUNTER overflow occurs (description of the reset counter <RST_CNT> see below).

<INIT_WDR> = '1':

If <INIT_WDR> = '1', an ERROR COUNTER overflow activates a reset [RST] (signal <WD_RST> becomes active). The signal <WD_RST> becomes active (i.e. '1') due to an ERROR COUNTER overflow when the value of the 3 bit reset counter <RST_CNT(2-0)> is 0..6. If the value of <RST_CNT> = "111" and an ERROR COUNTER overflow occurs <WD_RST> remains inactive (i.e. '0') and no reset is generated.

The "reset counter" <RST_CNT> is incremented by one during a sequencer-run due to an ERROR COUNTER overflow when <INIT_WDR> = '1' and <RST_CNT> is between 0 and 6. If <RST_CNT> = 7 and an ERROR COUNTER overflow occurs, the counter state remains 7. The counter can not be decremented and can only reset to zero by an active RST_UV signal.

The occurrence of a monitoring module reset is indicated via the flag <WDG_RST> = '1'. Reading the flag via SPI clears it automatically.

In effect maximum 7 monitoring module resets can be generated between 2 active RST_UV signal. (see also state table for <INIT_WDR> = '1' below).

The state of the "reset counter" <RST_CNT> can be read via SPI but cannot be changed.

Table 49. State for <INIT_WDR> = 1

RST_CNT old	"EC" > 7 and sequencer-run	RST_CNT new	WD_RST
000 .. 111	no	= RST_CNT old	'0', no monitoring module reset
000 .. 110	yes	= RST_CNT old + 1	'1', thus monitoring module reset
111	yes	= RST_CNT old = 111	'0', no monitoring module reset

In a factory testmode the pin [WDA] is always active '0'; the internal signal <WDA_INT> is not changed by the factory testmodes.

Note: There is no impact on internal power stages from active pin [WDA] in factory testmode.

Table 50. Reset-behaviour of <WDA_INT>, AB1 and <WD_RST>

Signal	Reset source	Reset state
WDA_INT	RST_UV	'1', i.e. pin WDA is active
AB1	RST_UV	'0', i.e. inactive
WD_RST	RST_UV	'0', i.e. inactive

Response comparison

The 2-bit counter <RESP_CNT (1-0)> counts the received bytes of the 32-bit response and controls the generation of the expected response. Its default value is "11" (corresponds to "waiting for RESP_BYTE3").

The <RESP_ERR> flag is set '1' when a response byte is incorrect. The flag remains '0' if the 32-bit response is correct. The ERROR COUNTER is updated with the flag. The default state of the flag is '0'.

The 2-bit counter <RESP_CNT(1-0)> and the <RESP_ERR> flag are reset to their corresponding default values at a sequencer-run. The reset condition of the counter <RESP_CNT (1-0)> and the <RESP_ERR> flag are the corresponding default states.

Procedure of the sequential response comparison:

<RESP_CNT(1-0)> = "11": switch the expected response for RESP_BYTE3 to the comparator

Write access: RESP_BYTE3

Set <RESP_CNT> to "10", update <RESP_ERR> flag

<RESP_CNT(1-0)> = "10": switch the expected response for RESP_BYTE2 to the comparator

Write access: RESP_BYTE2

set <RESP_CNT> to "01", update <RESP_ERR> flag

<RESP_CNT(1-0)> = "01": switch the expected response for RESP_BYTE1 to the comparator

Write access: RESP_BYTE1

set <RESP_CNT> to "00", update <RESP_ERR> flag

<RESP_CNT(1-0)> = "00": switch the expected response for RESP_BYTE0 to the comparator

Write access: RESP_BYTE0

Start sequencer (SEQU_START signal), set <RESP_CNT> to "11", update <RESP_ERR> flag (update ERROR COUNTER)

Sequencer clears <RESP_ERR> flag to '0'

SEQU_START = ¬(RESP_CNT1) AND ¬(RESP_CNT0) AND "response byte write"

Expected Responses:

$RESP_SOLL7 = REQU2 \text{ XOR } RESP_CNT0$

$RESP_SOLL6 = REQU0 \text{ XOR } RESP_CNT0$

$RESP_SOLL5 = REQU3 \text{ XOR } RESP_CNT0$

$RESP_SOLL4 = REQU1 \text{ XOR } RESP_CNT0$

$RESP_SOLL3 = ((REQU2 \text{ XOR } REQU0) \text{ XOR } REQU3) \text{ XOR } RESP_CNT1$

$RESP_SOLL2 = ((REQU0 \text{ XOR } REQU3) \text{ XOR } REQU1) \text{ XOR } RESP_CNT1$

$RESP_SOLL1 = ((REQU2 \text{ XOR } REQU0) \text{ XOR } REQU1) \text{ XOR } RESP_CNT1$

$RESP_SOLL0 = (RESP_CNT1 \text{ XOR } REQU3) \text{ XOR } REQU0$

Table 51. Expected responses

question REQU (3-0)	RESP_BYTE3	RESP_BYTE2	RESP_BYTE1	RESP_BYTE0
0	FF	0F	F0	00
1	B0	40	BF	4F
2	E9	19	E6	16
3	A6	56	A9	59
4	75	85	7A	8A
5	3A	CA	35	C5
6	63	93	6C	9C
7	2C	DC	23	D3
8	D2	22	DD	2D
9	9D	6D	92	62
A	C4	34	CB	3B
B	8B	7B	84	74
C	58	A8	57	A7
D	17	E7	18	E8
E	4E	BE	41	B1
F	01	F1	0E	FE

Reset behaviour

All monitoring module registers are reset by RST_UV. The following monitoring module components are also reset by RST_PRL:

Table 52. Reset behaviour

Component:	Reset Condition:
ERROR COUNTER	110b
Register for "EC>7"	,0'
Register RESPTIME	Maximum value: 0011 1111b
timer state	"000...00"

Note: The signal RST_PRL (partial reset) is active when RST or SW_RST (Softreset) is active.

Access during a sequencer-run

A sequencer-run (which means the same as a monitoring cycle) is initiated by the writing of a response (i.e. all answer bytes <RESP_BYTE3..0>) or a write to <RESPTIME> or by reaching "end of time window". It must not be interrupted by a new access, i.e. the monitoring module completes the action already started:

- A sequencer-run was initiated by a "response write": The sequencer completes its task with the data of the previous access and the new data are ignored.
- A sequencer-run was initiated by a "response-time write": The sequencer uses the response-time of the previous access, the error counter is correspondingly incremented by one and the <CHRT> bit (REQUHI register) is set and the new data are ignored. <CHRT> will be reset by reading and by the next start of a sequencer run (not reset by the sequencer run that is started by a "response-time write"!)
- A sequencer-run was initiated by "end of time window": The sequencer finishes the started run, the error counter is incremented by one and the new data are ignored.

The writing of a response-time during a sequencer-run must not set the <CHRT> bit (REQUHI register). The new response-time value is also not accepted. The writing of a response during a sequencer-run must not set the <W_RESP> bit, the new response is also not accepted.

Clock and time references

The monitoring module must work independently of the micro-controller clock so that it can monitor the timing of the micro-controller. Therefore, a separate oscillator is necessary. This oscillator is integrated in the L9779WD-SPI and provides a clock CLK1 for the monitoring module. Clocked with CLK1, a divider generates the base time of $101 \cdot 1/f_clk = 101 \cdot 1/64\text{kHz} = 1.58 \text{ ms}$ for the response-time and $8 \cdot 101 \cdot 1/64\text{kHz} = 8 \cdot 1.58 \text{ ms} = 12.6 \text{ ms}$ for the fixed time window. Accuracy of CLK1 is $\pm 5\%$ (or better).

The response-time is adjustable by the controller in the range 0ms to about 100ms (register RESPTIME). The response-time can be calculated with the equation $\text{response-time} = (1 + 101 \cdot \text{RESPTIME}) \cdot 1/f_clk$ (where f_CLK depends on CONFIG6 bit1 value: if High - default- f_clk = 64 kHz, if Low f_clk = 39 kHz).

The RESPTIME register is set to '0011 1111'b after a reset. The ERROR COUNTER is incremented by one if the controller changes the response-time. If the response-time is set



to 0ms, then the ERROR COUNTER is incremented by one even if a correct response is received within the time window. The maximum error reaction time is given by: maximum response-time, response at the end of a time-window and ERROR COUNTER 0 ' 5 * (100ms + 12.6ms) = 563ms.

Note that clock-tolerances have to be taken into account additionally.

Watchdog influence on power up/down management unit

The watchdog AB1 counter is increased every time the watchdog error counter is $EC > 7$, which means it has an overflow. If the AB1 counter reaches the value of 7 and a further error occurs, the system will be switched off same as it would happen in case of the already existing PWL_EN_TIMEOUTN signal.

Watchdog influence on smart power reset

WDA has influence on the RST pin only if the WDA error counter is $EC > 7$ and the resulting reset signal "WD_RST" is enabled by SPI configuration bit "INIT_WDR" in WR_RESPTIME command.

Watchdog influence on Lsa functions ([Section 6.8.1](#))

For Lsa functions OUT1, OUT2, OUT3, OUT4 (not OUT5).

In case of an internal WDA event (e.g. the WDA error counter is $EC > 4$ which results in the signal WDA_INT being set) or in case of the WDA pin being pulled low externally, the output stages OUT1, OUT2, OUT3, OUT4 go to inactive state.

Watchdog influence on LSd functions OUT13, OUT14 (starter relay drivers) [Section 6.8.4](#)

In case of an internal WDA event (e.g. the WDA error counter is $EC > 4$ which results in the signal WDA_INT being set) or in case of the WDA pin being pulled low externally, the OUT13 and OUT14 stages go to inactive state after the time delay THOLD if the WDA event is still active.

Watchdog influence on Ignition drivers IGN1, IGN2, IGN3, IGN4

In case of an internal WDA event (e.g. the WDA error counter is $EC > 4$ which results in the signal WDA_INT being set) or in case of the WDA pin is pulled low externally, the output stages go to inactive state.

Watchdog influence on CAN transceiver

The WDA has influence on the CAN if the SPI configuration bit CAN_TDI is set.

Once the CAN_TDI bit is set, in case of an internal WDA event (e.g. the WDA error counter is $EC > 4$ which results in the signal WDA_INT being set) or in case of the WDA pin is pulled low externally, the CAN goes to receive-only mode (RxOnly).

6.16 Serial interface

The L9779WD-SPI offers the possibility to communicate with a μ C using the Serial Peripheral Interface (SPI).

The serial communication is used:

- to set the parameter
- to read diagnosis
- to activate, to deactivate and to use the Query/Answer protocol
- to activate, to deactivate and to use the low side drivers
- to activate test mode (ST reserved)

6.16.1 SPI interface

The SPI interface consists of an input shift register, output shift register and four control signals. DIN is the data input to the input shift register. DO is the data output from the output shift register. SCK is the clock source input while CS is the active low chip select input.

6.16.2 SPI protocol

All SPI communications are executed in exact 16 bit increments. The L9779WD-SPI contains a data validation method through the SCK input to keep transmissions with not exactly 16 bits from being written to the device. The SCK input counts the number of received clocks and should the clock counter exceed or count fewer than 16 clocks, the received message is discarded without changes to internal registers.

The general format of the 16 bit transmission for global SPI interface is shown here below:

	D15	D14	D13	D12	D11	D10	D9	D8	D7	D6	D5	D4	D3	D2	D1	D0
DIN	X	ADD(4)	ADD(3)	ADD(2)	ADD(1)	ADD(0)	X	DATA IN or SUBADDRESS (if ADD[4:0]= 0x10)								Parity
DO	SPI error	ADD(4)	ADD(3)	ADD(2)	ADD(1)	ADD(0)	W/R	DATA OUT								Parity

Data to the device (i.e. DIN) consists of a five address bit, eight data bit and data parity. DIN data is the data to be written to the register indicated by address bit. Data returned from the device (i.e. DO) consists of SPI error bit, five address bit, eight data bit and data parity. DO data will be the contents of the register indicated by the address bits.

The communications is controlled through CS, enabling and disabling communication. When CS is at logic high, all SPI communication I/O is tri-stated and no data is accepted. When CS is low, data is latched on the rising edge of SCLK and data is shifted on the falling edge. The DIN pin receives serial data from the master with MSB first. Likewise for DO, data is read MSB first, LSB last. The failed transmission is indicated in the SPI_ERR bit.

[Table 55](#) reports register addresses. Registers differ between write-only and read-only registers.

Write-only registers return all zeroes in MISO DO-DATA OUT field of next frame, with the exception of CLOCK_UNLOCK_RSRST and START_REACT, which return LOCK and OUT_DIS status bit.

Read-only registers (ID and Diagnostic) have unique address 0x10 and are selected by 5bit sub-address in MOSI DI-DATA IN field. MISO DO returns 1 at D9 bit and 5bit sub address in ADD[4:0] field.

Timing characteristics

Figure 73. Timing characteristics diagram

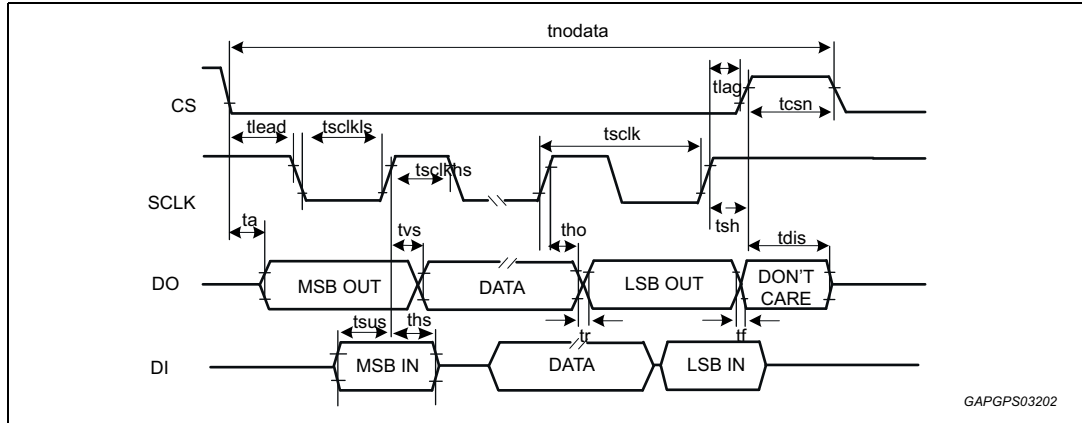

Table 53. Timing characteristics

Symbol	Parameter	Conditions	Min	Max	Units
f_{op}	Transfer frequency	Design Information	-	8	MHz
t_{sclk}	SCK period	Design Information	125	-	ns
t_{lead}	Enable Lead time	Design Information	525	-	ns
t_{lag}	Enable lag time	Design Information	50	-	ns
t_{sklks}	SCK high time	Design Information	38	-	ns
t_{sklks}	SCK low time	Design Information	38	-	ns
t_{sus}	DIN input setup time	Design Information	20	-	ns
t_{th}	DIN input hold time	Design Information	20	-	ns
t_a	DO access time	50 pF load	-	60	ns
t_{dis}	DO disable time	50 pF load	-	100	ns
t_{vs}	DO output valid time	50 pF load	-	66	ns
t_{tho}	DO output hold time	50 pF load	0	-	ns
t_r	DO rise time	50 pF load	-	30	ns
t_f	DO fall time	50 pF load	-	30	ns
t_{csn}	CS negated time	Design Information	640	-	ns
t_{sh}	SCK hold time	Design Information	20	-	ns
t_{csgrt}	CS noise glitch rejection time	-	50	300	ns
t_{nodata}	SPI interframe time	Design Information	1.5	-	μ s

Electrical characteristics

Table 54. Electrical characteristics

Pin	Symbol	Parameter	Test condition	Min	Typ	Max	Unit
SCK	SCK _L	Low input level	-	-0.3	-	1.1	V
	SCK _H	High input level	-	2.3	-	VDD5 +0.3	V
	V _{HYST}	Hysteresis	-	0.1	-	-	V
	I _{IN}	Input current	-	-	-	5	µA
DIN	SCK _L	Low input level	-	-0.3	-	1.1	V
	SCK _H	High input level	-	2.3	-	VDD5 +0.3	V
	V _{HYST}	Hysteresis	-	0.1	-	-	V
	I _{IN}	Input current	-	-	-	5	µA
DO	VDO _L	DO output low level	Isink current = 2 mA	-	-	0.5	V
	VDO _H	DO output high level	Isource current = 2 mA	VDD5 -0.5	-	-	V
CS	EN _L	Low input level	-	-0.3	-	1.1	V
	EN _H	High input level	-	2.3	-	VDD5 +0.3	V
	V _{HYST}	Hysteresis	-	0.1	-	-	V
	I _{IN}	Input current	-	-	-	5	µA
	R _{PU}	Pull up resistor	-	50	-	250	kΩ

6.16.3 SPI registers

Table 55. SPI registers

Register	R/W	Address	Description
CONFIG_REG1	W	0x01	Configuration registers
CONFIG_REG2	W	0x02	
CONFIG_REG3	W	0x03	
CONFIG_REG4	W	0x04	
CONFIG_REG5	W	0x05	
CONFIG_REG6	W	0x06	
CONFIG_REG7	W	0x07	
CONFIG_REG9/SPI RESPTIME	W	0x11	
CONFIG_REG10/CPS	W	0x12	

Table 55. SPI registers (continued)

Register	R/W	Address	Description
LOCK_UNLOCK_SW_RST	W	0x0C	Disable writing of all configuration bits/ software reset for the device
START_REACT	W	0x0D	Enable power stages/MRD reactivate
WD_ANSW/WDA RESP CONFIG_REG8	W	0x0E	Communicate the WD appropriate answer to WD query/U1A9 WDA Response to query
CONTR_REG1	W	0x08	Control register to switch on/off the OUT
CONTR_REG2	W	0x09	
CONTR_REG3	W	0x0A	
CONTR_REG4	W	0x0B	
Following Registers have 0x10+subaddress SPI format			
IDENT_REG	R	0x10+0x00	Identifier (000)
DIA_REG1	R	0x10+0x01	Diagnosis information of device
DIA_REG2	R	0x10+0x02	
DIA_REG3	R	0x10+0x03	
DIA_REG4	R	0x10+0x04	
DIA_REG5	R	0x10+0x05	
DIA_REG6	R	0x10+0x06	
DIA_REG7	R	0x10+0x07	
DIA_REG8	R	0x10+0x08	
DIA_REG9	R	0x10+0x09	
DIA_REG10	R	0x10+0x0A	
DIA_REG11	R	0x10+0x0B	
DIA_REG12	R	0x10+0x0C	Diagnostic register 12
DIA_REG13	R	0x10+0x0D	WDA RESPTIME
DIA_REG14	R	0x10+0x0E	WDA REQULO
DIA_REG15	R	0x10+0x0F	WDA REQUHI
DIA_REG16	R	0x10+0x10	WDA RST_AB1_CNT

Command register

Table 56. CLOCK_UNLOCK_SW_RST

Bit	DIN	DO
15	X	SPI ERROR
14	ADD(4)	ADD(4)
13	ADD(3)	ADD(3)
12	ADD(2)	ADD(2)
11	ADD(1)	ADD(1)
10	ADD(0)	ADD(0)
9	X	0
8	X	0
7	X	0
6	X	0
5	X	0
4	X	0
3	X	0
2	SW_RESET	0
1	LOCK	LOCK
0	Odd Parity	Odd Parity

This command disables (“lock”) writing of all configuration registers. The commands have no relevant data as command data bit – they may be set to ‘1’ or ‘0’.

Default state is configuration registers not locked.

The content of lockable bit is valid both if the bits are locked or if they are unlocked. Writing data to the bit is possible if the bits are unlocked; the new values become valid during the execution of the write command.

This command generates a L9779WD-SPI internal reset initiated by the µC’s software (“software reset”) that clears all the configuration and diagnostic registers and switch-off all the drivers.

The command has no relevant data as command data bit – they may be set to ‘1’ or ‘0’.

Table 57. START_REACT

Bit	DIN	DO
15	X	SPI ERROR
14	ADD(4)	ADD(4)
13	ADD(3)	ADD(3)
12	ADD(2)	ADD(2)
11	ADD(1)	ADD(1)

Table 57. START_REACT (continued)

Bit	DIN	DO
10	ADD(0)	ADD(0)
9	X	0
8	X	0
7	X	0
6	X	0
5	X	0
4	X	0
3	STOP	0
2	START	0
1	MRD_REACT	OUT_DIS
0	Odd Parity	Odd Parity

The command START sets the bit <OUT_DIS> to '0'. With <OUT_DIS> = '0' the outputs [OUT1...OUT10] [OUT13...OUT28] and [IGN1...IGN4] can be activated using control registers. After a reset (default state) the bit is <OUT_DIS>='1' and the outputs are disabled (so any SPI data frame writing control registers is ignored and the power stages are all switched off).

The command has no relevant data as command data bit – they may be set to '1' or '0'.

This command allows the μ C turning on the MRD if it is switched off due to over current.

Configuration registers

CONFIG_REG1

Configuration register 1

7	6	5	4	3	2	1	0
RESERVED						VRS mode	MRD_OT_DID
-						W	W

Address: 0 0001
Type: W (write access: WRITE_CONFIG1)
Reset: 0000 1000
 [7:5] RESERVED
 [4:2] RESERVED
 [1] VRS mode:
 0 = limited adaptive (default)
 1 = full adaptive
 [0] MRD_OT_DIS: Disables OT switch_off for MRD:
 0 = MRD OT switches off the driver
 1 = MRD OT does NOT switch off the driver

CONFIG_REG2

Configuration register 2

7	6	5	4	3	2	1	0
RESERVED						Charge pump OFF	LS_IGN_OFF
-						W	W

Address: 0 0010
Type: W (write access: WRITE_CONFIG2)
Reset: 0000 1000
 [7:5] RESERVED
 [4:2] RESERVED
 [1] Charge pump OFF
 0= ON (default)
 1= OFF
 [0] LS_IGN_OFF Control LS stage of IGN driver
 0 = normal behaviour
 1 = LS of IGN driver always OFF

CONFIG_REG3**Configuration register 3**

7	6	5	4	3	2	1	0
RESERVED						EN_FALLING_FILT	HYS_FB_SEL
-						W	

Address: 0 0011

Type: W (write access: WRITE_CONFIG3)

Reset: 0000 1000

[7:5] RESERVED

[4:2] RESERVED

[1] EN_FALLING_FILT:

0 = Falling edge filter disabled

1 = Falling edge filter enabled

[0] HYS_FB_SEL:

0 = VRS hyst. Feedback connected before adaptative filter

1 = VRS hyst. Feedback connected after adaptative filter

CONFIG_REG4

Configuration register 4

7	6	5	4	3	2	1	0
PWL_TIMEOUT_CONF[2:0]			OFF_LCDR	RESERVED		ISO_SRC	LOCK
W				-		W	

Address: 0 0100

Type: W (write access: WRITE_CONFIG4)

Reset: 0000_0010

[7:5] PWL_TIMEOUT_CONF[2:0]: Power latch mode time-out configuration.

- 000: Disabled (default)
- 001: 4.7 minutes ±5%
- 010: 9 minutes ±5%
- 011: 19 minutes ±5%
- 100: 28 minutes ±5%
- 101: 37 minutes ±5%
- 110: 75 minutes ±5%
- 111: 470 ms ±5%

[4] OFF_LCDR: Off state diagnosis for Low-current drive
 1 = Off state diagnosis and the bias current of OUT20 is active
 0 = Off state diagnosis and the bias current of OUT20 is disabled

[3:2] RESERVED

[1] ISO_SRC: Slew-rate control for the ISO9141 serial interface (K-Line)
 0 = No slew rate limitation
 1 = Slew-rate limitation active

[0] LOCK: Lock bit status. Set by LOCK command and cleared with UNLOCK command
 1 = ALL configuration registers are locked and cannot be changed
 0 = all configuration registers can be changed



CONFIG_REG5

Configuration register 5

7	6	5	4	3	2	1	0
RESERVED	RESERVED	VRS_DIAG	VRS_MODE1	VRS_MODE0	VRS_HYST2	VRS_HYST1	VRS_HYST0
-	-	W					

Address: 0 0101

Type: W (write access: WRITE_CONFIG5)

Reset: 1101_1000

[7:6] RESERVED: not used

[5] If fully adaptive mode selected:

VRS diag: VRS diagnosis enable

1: diagnosis function is enabled

0: diagnosis function is disabled

If limited adaptive mode selected:

Forces VRS minimum hysteresis ($5 \hat{I}/4A$)

1: minimum hysteresis forced

0: normal operation as per VRS_HYST configuration

[4:3] VRS_MODE

00: Internal auto-adaptive hysteresis OFF, internal auto-adaptive filter time OFF

01: Internal auto-adaptive hysteresis ON, internal auto-adaptive filter time OFF

10: Internal auto-adaptive hysteresis OFF, internal auto-adaptive filter time ON

11: Internal auto-adaptive hysteresis ON, internal auto-adaptive filter time ON

[2:0] VRS_HYST

000: Hys current = 17 μ A (Hys VRS = 347 mV with 10 k Ω ext resistors) [default]

001: Hys current = 5 μ A (Hys VRS=100mV with 10 k Ω ext resistors)

010: Hys current = 10 μ A (Hys VRS=200mV with 10 k Ω ext resistors)

011: Hys current = 17 μ A (Hys VRS=347mV with 10 k Ω ext resistors)

100: Hys current = 32 μ A (Hys VRS=644mV with 10 k Ω ext resistors)

101: Hys current = 51 μ A (Hys VRS=967mV with 10 k Ω ext resistors)

110: Hys current = 17 μ A (Hys VRS=347mV with 10 k Ω ext resistors)

111: Hys current = 0 μ A (used only for test purpose)

Note: When VRS limited amplitude adaptive mode is set, VRS_HYST limits the minimum hysteresis to the set value.

When VRS limited mode is set, filter time must be enabled at operation start, and shall never be disabled afterwards.

When VRS limited mode is set, VRS diagnostic function is not available.

CONFIG_REG6

Configuration register 6

7	6	5	4	3	2	1	0
CAN_ERR_EN	NL_RST	PWL_EN_N/ SEO_EN_N	PSOFF	VDD5_UV RST mask	VDD5_UV WDA mask	WDA time base setting (RESPTIME)	PWL/SEO timeout
W							

Address: 0 0110

Type: W (write access: WRITE_CONFIG6)

Reset: 0010 0010

- [7] CAN_ERR_EN: CAN error handling
1: CAN error handling enabled
0: CAN error handling disabled
- [6] NL_RST: Reset generation during Power latch mode when KEY_ON 0 --> 1
1: reset generated
0: reset not generated
- [5] PWL_EN_N: Power latch mode enable
PWL_EN_N/SEO_EN_N: Power latch/secure engine off mode enable
1: power latch mode function is disabled (default)
0: power latch mode function is enabled
- [4] PSOFF: Power supply off (VDD5, VTRK1, VTRK2, Charge-pump, internal supply) when KEY_ON = 0 and PWL_EN_N = 0
0: switch off power supply and switch off MRD
1: do not switch off power supply and switch off MRD
- [3] VDD5_UV RST mask
1: mask VDD5_UV with generating RST event
0: mask removed (default), VDD5_UV event generates RST
- [2] VDD5_UV WDA mask
1: mask VDD5_UV with generating WDA event
0: mask removed (default). Any VDD5_UV event pulls WDA pin low and disables safety drivers
- [1] WDA time base setting
This bit selects the RESPTIME time base
1: (default) sets time base to 1/64 kHz
0: sets time base to 1/39 kHz
- [0] PWL/SEO timeout
0: PWL timeout counter has priority over SEO (default)
1: SEO timeout counter has priority over PW

CONFIG_REG7

Configuration register 7

7	6	5	4	3	2	1	0
IGN_DIA_MODE	IGN_DIA_SGEN	TD_MASK_X2	CPS/Stepper Unlock	OUTC_HS_EN_LB	OUTA_HS_EN_LB	OUT14_EN_LB	OUT13_EN_LB
W							

Address: 0 0111

Type: W (write access: WRITE_CONFIG7)

Reset: 0101 0000

- [7] IGN_DIA_MODE: IGN diagnosis mode for short to battery:
1: latch mode
0: no latch mode
- [6] IGN_DIA_SGEN: IGN diagnosis enable for short to ground:
1: Current diagnosis enabled
0: Voltage diagnosis disabled
- [5] TD_MASK_X2:
0: Td_mask as specified in respective tables for OUT13 to OUT28
1: Td_mask doubled for OUT13 to OUT28
- [4] CPS/Stepper Unlock bit:
1: Stepper mode selected (default)
0: CPS mode selected
- [3] OUTC_HS_EN_LB: Low battery function enable
1: LB function is enabled for OUTC_HS
0: LB function is disabled for OUTC_HS
- [2] OUTA_HS_EN_LB: Low battery function enable
1: LB function is enabled for OUTA_HS
0: LB function is disabled for OUTA_HS
- [1] OUT14_EN_LB: Low battery function enable
1: LB function is enabled for OUT14
0: LB function is disabled for OUT14
- [0] OUT13_EN_LB: Low battery function enable
1: LB function is enabled for OUT13
0: LB function is disabled for OUT13

Note: The bit OUTA_HS, OUTC_HS_EN_LB has priority over the CPS_CONFx bit, this means that if one of OUT21,25_EN_LB is set to 1 the OUT21...28 become independent power stages.

WD_ANSW/WDA RESP/CONFIG_REG8

Configuration register 8

7	6	5	4	3	2	1	0
RESP	RESP	RESP	RESP	RESP	RESP	RESP	RESP
W							

Address: 0 1110

Type: W

Reset: -

[7:0] RESP: the answer of the μ C to the monitoring module question of the U-Chip - to the U-Chip-internal logic of the monitoring module.

CONFIG_REG9/SPI RESPTIME

Configuration register 9

7	6	5	4	3	2	1	0
INIT_WDR	CAN_TDI	RESPTIME	RESPTIME	RESPTIME	RESPTIME	RESPTIME	RESPTIME
W							

Address: 1 0001

Type: W

Reset: -

- [7] IINIT_WDR (enable WDA reset)
- [6] CAN_TDI (disable CAN in case of WDA event)
- [5:0] RESPTIME of the monitoring module



CONFIG_REG10 (CPS Configuration register)

Configuration register 10

7	6	5	4	3	2	1	0
see Table 37							CPS_CONF
W							

Address: 1 0010
Type: WR_CPS
Reset: -

[7:1] See [Table 37](#)

- [0] CPS_CONF (CPS mode is enabled if REG7 bit4 is cleared first)
- 1: OUTA...OUTD are configured as 2 full-bridge for stepper motor driving (default)
- 0: OUTA...OUTD are configured as half bridges

IDENT_REG/DIA_REG[1:5]

Diagnostic register 1, 2, 3, 4, 5

	7	6	5	4	3	2	1	0
DIA_REG1	OUT4_DIAG		OUT3_DIAG		OUT2_DIAG		OUT1_DIAG	
DIA_REG2	0	0	OUT7_DIAG		OUT6_DIAG		OUT5_DIAG	
DIA_REG3	OUT14_DIAG		OUT13_DIAG		WDA_STATUS	1	0	0
DIA_REG4	OUT18_DIAG		OUT17_DIAG		OUT16_DIAG		OUT15_DIAG	
DIA_REG5	RESERVED				OUT20_DIAG		0	0

Address: 1 0000
Subaddress: 0000 0001,
 0000 0010,
 0000 0011,
 0000 0100,
 0000 0101
Type: R (Read only)
Reset: 0000 0000

- DIA_REG1:[7:6] OUT4_DIAG: Diagnosis bit of power stage OUT4
 - 00: Short-circuit to ground (SCG)
 - 01: Open load (OL)
 - 10: Short-circuit to BAT (SCB)
 - 11: Power stage OK NO FAIL
- DIA_REG1:[5:4] OUT3_DIAG: Diagnosis bit of power stage OUT3
 - 00: Short-circuit to ground (SCG)
 - 01: Open load (OL)
 - 10: Short-circuit to BAT (SCB)
 - 11: Power stage OK NO FAIL



- DIA_REG1:[3:2] OUT2_DIAG: Diagnosis bit of power stage OUT2
00: Short-circuit to ground (SCG)
01: Open load (OL)
10: Short-circuit to BAT (SCB)
11: Power stage OK NO FAIL
- DIA_REG1:[1:0] OUT1_DIAG: Diagnosis bit of power stage OUT1
00: Short-circuit to ground (SCG)
01: Open load (OL)
10: Short-circuit to BAT (SCB)
11: Power stage OK NO FAIL
- DIA_REG2:[7:6] 00
- DIA_REG2:[5:4] OUT7_DIAG: Diagnosis bit of power stage OUT7
00: Short-circuit to ground (SCG)
01: Open load (OL)
10: Short-circuit to BAT (SCB)
11: Power stage OK NO FAIL
- DIA_REG2:[3:2] OUT6_DIAG: Diagnosis bit of power stage OUT6
00: Short-circuit to ground (SCG)
01: Open load (OL)
10: Short-circuit to BAT (SCB)
11: Power stage OK NO FAIL
- DIA_REG2:[1:0] OUT5_DIAG: Diagnosis bit of power stage OUT5
00: Short-circuit to ground (SCG)
01: Open load (OL)
10: Short-circuit to BAT (SCB)
11: Power stage OK NO FAIL
- DIA_REG3:[7:6] OUT14_DIAG: Diagnosis bit of power stage OUT14
00: Short-circuit to ground (SCG)
01: Open load (OL)
10: Short-circuit to BAT (SCB)
11: Power stage OK NO FAIL
- DIA_REG3:[5:4] OUT13_DIAG: Diagnosis bit of power stage OUT13
00: Short-circuit to ground (SCG)
01: Open load (OL)
10: Short-circuit to BAT (SCB)
11: Power stage OK NO FAIL
- DIA_REG3:[3] WDA STATUS: status of WDA pin, not latched
- DIA_REG3:[2] RESERVED: not used
- DIA_REG3:[1:0] 00
- DIA_REG4:[7-6] OUT18_DIAG: Diagnosis bit of power stage OUT18
00: Short-circuit to ground (SCG)
01: Open load (OL)
10: Short-circuit to BAT (SCB)
11: Power stage OK NO FAIL

DIA_REG4:[5-4] OUT17_DIAG: Diagnosis bit of power stage OUT17
00: Short-circuit to ground (SCG)
01: Open load (OL)
10: Short-circuit to BAT (SCB)
11: Power stage OK NO FAIL

DIA_REG4:[3-2] OUT16_DIAG: Diagnosis bit of power stage OUT16
00: Short-circuit to ground (SCG)
01: Open load (OL)
10: Short-circuit to BAT (SCB)
11: Power stage OK NO FAIL

DIA_REG4:[1-0] OUT15_DIAG: Diagnosis bit of power stage OUT15
00: Short-circuit to ground (SCG)
01: Open load (OL)
10: Short-circuit to BAT (SCB)
11: Power stage OK NO FAIL

DIA_REG5:[7:4] RESERVED: All bit read 1

DIA_REG5:[3-2] OUT20_DIAG: Diagnosis bit of power stage OUT20
00: Short-circuit to ground (SCG)
01: Open load (OL)
10: Short-circuit to BAT (SCB)
11: Power stage OK NO FAIL

DIA_REG5:[1-0] 00

Note: All diagnosis bits (including OT1, F1, OT2, F2) will be cleared automatically by reading – i.e. if a diagnosis bit indicates a fault this fault has occurred after the last read access to this register.

Diagnostic register 6 and 7

DIA_REG6

Diagnostic register 6

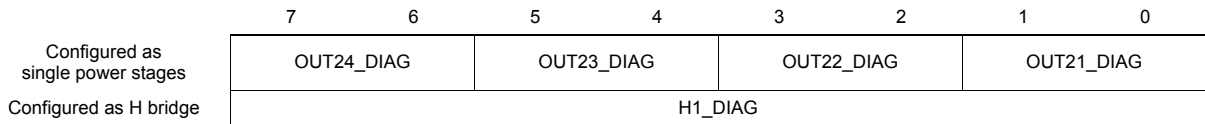

Address: 1 0000
Subaddress: 0000 0110
Type: R (Read only)
Reset: 0000 0000

Configured as single power stages

- [7-6] OUT24_diag[1:0]: Diagnosis bit of OUT24
 00: Short-circuit to ground
 01: Open load (OL)
 10: Short-circuit to BAT (SCB)
 11: Power stage OK NO FAIL
- [5-4] OUT23_diag[1:0]: Diagnosis bit of OUT23
 00: Short-circuit to VB
 01: Open load (OL)
 10: Short-circuit to GND
 11: Power stage OK NO FAIL
- [3-2] OUT22_diag[1:0]: Diagnosis bit of OUT22
 00: Short-circuit to ground
 01: Open load (OL)
 10: Short-circuit to BAT (SCB)
 11: Power stage OK NO FAIL
- [1-0] OUT21_diag[1:0]: Diagnosis bit of OUT21
 00: Short-circuit to VB
 01: Open load (OL)
 10: Short-circuit to GND
 11: Power stage OK NO FAIL

Configured as H bridge

- [7-0] H1_diag[7:0]: Diagnosis bit of H1 bridge
 00000001: Short to Ground (OFF)
 00000101: Short to VBAT (OFF)
 00000100: Open Load (OFF)
 00000010: Open Load (ON)
 00000011: Over current (ON)
 00000111: Fault detection running (ON)
 11111111: Power stages OK NO FAULT
 All other combinations: NOT USED



DIA_REG7

Diagnostic register 7

	7	6	5	4	3	2	1	0
Configured as single power stages	OUT28_DIAG		OUT27_DIAG		OUT26_DIAG		OUT25_DIAG	
Configured as H bridge	H2_DIAG							

Address: 1 0000
Subaddress: 0000 0111
Type: R (Read only)
Reset: 0000 0000

Configured as single power stages

- [7-6] OUT28_DIAG[1:0]: Diagnosis bit of OUT28
 00: Short-circuit to ground
 01: Open load (OL)
 10: Short-circuit to BAT (SCB)
 11: Power stage OK NO FAIL
- [5-4] OUT27_DIAG[1:0]: Diagnosis bit of OUT27
 00: Short-circuit to ground
 01: Open load (OL)
 10: Short-circuit to BAT (SCB)
 11: Power stage OK NO FAIL
- [3-2] OUT26_DIAG[1:0]: Diagnosis bit of OUT26
 00: Short-circuit to VB
 01: Open load (OL)
 10: Short-circuit to GND
 11: Power stage OK NO FAIL
- [1-0] OUT25_DIAG[1:0]: Diagnosis bit of OUT25
 00: Short-circuit to VB
 01: Open load (OL)
 10: Short-circuit to GND
 11: Power stage OK NO FAIL

Configured as H bridge

- [7-0] H2_diag[7:0]: Diagnosis bit of H2 bridge
 00000001: Short to Ground (OFF)
 00000101: Short to VBAT (OFF)
 00000100: Open Load (OFF)
 00000010: Open Load (ON)
 00000011: Over current (ON)
 00000111: Fault detection running (ON)
 11111111: Power stages OK NO FAULT
 All other combinations: NOT USED

DIA_REG8

Diagnostic register 8

7	6	5	4	3	2	1	0
IGN4_DIAG[1:0]		IGN3_DIAG[1:0]		IGN2_DIAG[1:0]		IGN1_DIAG[1:0]	

Address: 1 0000

Subaddress: 0000 1000

Type: R (Read only)

Reset: 0000 0000

- [7:6] IGN4_DIAG[1:0]: Diagnosis bit of IGN4
 - 00: Short-circuit to ground (SCG)
 - 01: Open load (OL)
 - 10: Short-circuit to BAT (SCB)
 - 11: Power stage ok NO FAIL
- [5:4] IGN3_DIAG[1:0]: Diagnosis bit of IGN3
 - 00: Short-circuit to ground (SCG)
 - 01: Open load (OL)
 - 10: Short-circuit to BAT (SCB)
 - 11: Power stage ok NO FAIL
- [3:2] IGN2_DIAG[1:0]: Diagnosis bit of IGN2
 - 00: Short-circuit to ground (SCG)
 - 01: Open load (OL)
 - 10: Short-circuit to BAT (SCB)
 - 11: Power stage ok NO FAIL
- [1:0] IGN1_DIAG[1:0]: Diagnosis bit of IGN1
 - 00: Short-circuit to ground (SCG)
 - 01: Open load (OL)
 - 10: Short-circuit to BAT (SCB)
 - 11: Power stage ok NO FAIL

DIA_REG9

Diagnostic register 9

7	6	5	4	3	2	1	0
KEY_ON_STATUS	MRD_OVC	VRS_STAT	VRS_DIAG	VTRK2_DIAG[1:0]		VTRK1_DIAG[1:0]	
R/W							

Address: 1 0000

Subaddress: 0000 1001

Type: R (Read only)

Reset: 0000 0000

- [7] KEY_ON_STATUS
 - 1: KEY_ON voltage above KEY_ON_H
 - 0: KEY_ON voltage below KEY_ON_L
- [6] MRD_OVC
 - 1: Current MRD status is OFF due to previous Over current
 - 0: Current MRD status is ON (no OVC detected)
- [5] VRS_STAT
 - 1: Diag ON
 - 0: Diag OFF
- [4] VRS_DIAG
 - 0: No Fault
 - 1: Generic fault detected
- [3-2] VTRK2_DIAG[1:0]: Diagnosis bit of VTRK2
 - 00: Not used
 - 01: Overload condition/out of regulation
 - 10: Overvoltage (OV) or over temperature (OT) (Lower priority respect to Overload condition)
 - 11: Sensor supply VTRK ok NO FAIL
- [1-0] VTRK1_DIAG[1:0]: Diagnosis bit of VTRK1
 - 00: Not used
 - 01: Overload condition/out of regulation
 - 10: Overvoltage (OV) or over temperature (OT) (Lower priority respect to overload condition)
 - 11: Sensor supply VTRK OK NO FAIL

DIA_REG10

Diagnostic register 10

7	6	5	4	3	2	1	0
TNL_RST	F1	CRK_RST	F2	VDD5_OV	V3V3_UV	OUT_DIS	OV_RST

Address: 1 0000

Subaddress: 0000 1010

Type: R (Read only)

Reset: 0000 0000

- [7] TNL_RST
0: No reset generated
1: Reset generated by TNL
- [6] F1
0: No fault
1: any fault occurred in OUT1...10, OUT13...20, IGN1...4
- [5] CRK_RST
0: No reset generated
1: Reset generated by VDD_UV (t<THOLD)
- [4] F2
0: No fault
1: any fault occurred in OUT21...28
- [3] VDD5_OV
0: No fault
1: Overvoltage on VDD5 regulator
- [2] V3V3_UV
0: No fault
1: Undervoltage on V3V3 regulator
- [1] OUT_DIS
0: All OUT can be switched ON
1: All OUT disabled (except MRD and supplies)
- [0] OV_RST
0: No fault
1: Power stages were switched off due to battery overvoltage

Note: <OUT_DIS>: this bit has to be set to 0 with the command START before power stages OUTx and IGNx can be activated. As long as <OUT_DIS>=1 any data for these power stages are ignored. It is not affected by reading, and it is reset by POR, software reset SW_RST command and when the RST pin is asserted.



DIA_REG11

Diagnostic register 11

7	6	5	4	3	2	1	0
OT1	OT2	OT3	OT4	VDD5UV_RST	CAN_ERROR	WD_FAULT_LATCHED	0

Address: 1 0000

Subaddress: 0000 1011

Type: R (Read only)

Reset: 0000 0000

- [7] OT1
0: No fault
1: Over temperature occurred in VTRK1,2
- [6] OT2
0: No fault
1: Over temperature occurred in the OUTx and IGNx
- [5] OT3
0: No fault
1: Over temperature occurred in MRD
- [4] OT4
0: No fault
1: Over temperature occurred in V3V3
- [3] VDD5UV_RST
0: No reset generated
1: Reset generated by VDD_UV (t>THOLD)
- [2] CAN_ERROR
0: No fault
1: fault present (one of the 4 possible error on CAN)
- [1] WD_FAULT_LATCHED
1: WDA has generated a RST event
0: no event
- [0] 0

DIA_REG12

Diagnostic register 12

7	6	5	4	3	2	1	0
RESERVED	WD_FAULT_LATCHED	SEO OUT1-4	SEO OUT1314	WD_FAULT	RESERVED		KEY_ON_FLT

Address: 1 0000

Subaddress: 0000 1100

Type: R (Read only)

Reset: 0000 0000

[7] RESERVED

[6] WDA_FAULT latched:
 1: WDA has generated a RST event
 0: no event

[5] SEO event when the OUT1-4 are switched off after 225 ms

[4] SEO event when the OUT13-14 after 600ms when KEY is OFF

[3] WDA_FAULT not latched:
 1: WDA has generated a RST event (the DIA_REG12 is read by READ_DATA 7 but the bit WD_FAULT_LATCHED is reset by READ_DATA5).
 0: no event

[2:1] RESERVED: not used

[0] KEY_ON_FLT: Key on after filter

Watchdog related SPI registers

SPI registers WDA_RESPTIME,REQULO, REQUHI, RST_AB1_CNT are defined as here below:

DIA_REG13/WDA_RESPTIME**Diagnostic register 13**

7	6	5	4	3	2	1	0
0	0	RESPTIME5	RESPTIME4	RESPTIME3	RESPTIME2	RESPTIME1	RESPTIME0
R							

Address: 1 0000

Subaddress: 0000 1101

Type: R (Read only)

Reset: 0011 1111b (reset source: Bit 5-0: RST_UV, RST_PRL; Bit 6-7: RST_UV)

[7] 0

[6] 0

[5-0] RESPTIME (5-0): Response-time = $(1 + 101 \cdot \text{RESPTIME}(5-0)) \cdot 1/f_{\text{clk}}$ with $f_{\text{clk}} = 64\text{kHz}$

The error counter is incremented by one on a controller write access to this register!
not locked by command LOCK

<RESPTIME(5..0)> may be written by the command WR_RESPTIME

DIA_REG14/REQULO**Diagnostic register 14**

7	6	5	4	3	2	1	0
WDA_INT	ERR_CNT2	ERR_CNT1	ERR_CNT0	REQU3	REQU2	REQU1	REQU0
R							

Address: 1 0000

Subaddress: 0000 1110

Type: R (Read only)

Reset: 1110 0000b (reset source: Bit 6-4: RST_UV, RST_PRL; Bit 7, 3-0: RST_UV)

[7] WDA_INT: '1': ERROR COUNTER > 4

[6-4] ERR_CNT (2-0): value of the ERROR COUNTER

[3-0] REQU (3-0): 4-bit question

DIA_REG15/REQUHI

Diagnostic register 15

7	6	5	4	3	2	1	0
RESP_CNT1	RESP_CNT0	RESP_ERR	RESP_Z0	CHRT	W_RESP	NO_RESP	RESP_TO_EARLY
R							

Address: 1 0000

Subaddress: 0000 1111

Type: R (Read only)

Reset: 1100 0000b (reset source: RST_UV, Bit 4 additionally RST_PRL)

- [7-6] RESP_CNT(1-0):
'1': Response before time window was opened; reset to zero at sequencer-run⁽¹⁾
- [5] RESP_ERR:
'1': 1 byte of the 32-bit response is incorrect⁽¹⁾
- [4] RESP_Z0:
'1': Controller set response-time to 0ms; a correct response within the time window nevertheless increments the error counter by one '0': Response-time is greater than 0ms
- [3] CHRT:
'1': Controller has changed response-time; reset to zero after a read access and after the next sequencer run
- [2] W_RESP:
'1': incorrect response in value; reset to zero at sequencer-run ⁽¹⁾
- [1] NO_RESP:
'1': no response; timer is restarted automatically; reset to zero after a read access
- [0] RESP_TO_EARLY:
'1': Response before time window was opened; reset to zero at sequencer-run ⁽¹⁾

1. Sequencer-run: A sequencer-run is initiated by the writing of a complete response (RESP_BYTE3âRESP_BYTE0) or by writing of a response-time <RESPTIME> or by reaching the end of a time window. In case WDA reference time base (1/f_clk) has to be changed to f_clk = 39 kHz, CONFIG6 bit1 has to be written to 0 before sequencer-run is started.

RESP_TO_EARLY = '1':

monitoring module has received a response before beginning of the time window and therefore this was rejected. Reception of a response means "end of reception of RESP_BYTE0" after the other response bytes (i.e. RESP_BYTE3, RESP_BYTE2, RESP_BYTE1 - in this order!) have been received.

NO_RESP = '1':

monitoring module has received no response at all or a response too late after the time window already closed. However, a response too late might be read as RESP_TO_EARLY, as a too late response is at the same time a too early response concerning the next WDG cycle. Which results in the NO_RESP monitoring being overwritten by a RESP_TO_EARLY monitoring.

This means that no "end of reception of RESP_BYTE0" was detected before the end of the time window - neither during the time window nor before beginning of the time window. (Remember: RESP_BYTE0 is the last of four response bytes!)



W_RESP = '1':

an error occurred during the sequencer run before.

RESP_ERR = '1':

an error occurred during the actual sequencer run. The bit will be set to '1' after receiving any incorrect answer byte and will remain '1' until the end of the actual sequencer run (no matter if the other answer bytes in this sequencer run are correct or not).

At the end of a sequencer run the error bit W_RESP will be set to the actual value of RESP_ERR, and thereafter the error bit RESP_ERR will be cleared to '0'.

RESP_CNT = '11': waiting for RESP_BYTE3

RESP_CNT = '10': waiting for RESP_BYTE2 (after RESP_BYTE3 was received)

RESP_CNT = '01': waiting for RESP_BYTE1 (after RESP_BYTE2 was received)

RESP_CNT = '00': waiting for RESP_BYTE0 (after RESP_BYTE1 was received)

DIAG_REG16/RST_AB1_CNT

Diagnostic register 16

7	6	5	4	3	2	1	0
0	0	AB1_CNT2	AB1_CNT1	AB1_CNT0	RST_CNT2	RST_CNT1	RST_CNT0
R							

Address: 1 0000

Subaddress: 0001 0000

Type: R (Read only)

Reset: 0000 0000b (reset source: Bit 6...0: only RST_UV; RST_PRL has no effect)

[7] 0

[6] 0

[5-3] AB1_CNT (2-0)

[2-0] RST_CNT (2-0) reset counter RST_CNT

Control registers CONTR1 to 4

They control the output stages OUT1...10, OUT13...20, OUT21...28 and IGNn.

CMD = 1 OUTPUT ON
 CMD = 0 OUTPUT OFF

CONTR_REG1

Control register 1

7	6	5	4	3	2	1	0
CMD_OUT1	CMD_OUT2	CMD_OUT3	CMD_OUT4	CMD_OUT5	CMD_OUT20	RESERVED	RESERVED
W							

Address: 0 1000

Type: Via DATA frame

Reset: 0000 0000 (ALL outputs switched OFF)

- [7] CMD_OUT1
 - 1: OUT1 - Power stage switched ON
 - 0: OUT1 - Power stage switched OFF
- [6] CMD_OUT2
 - 1: OUT2 - Power stage switched ON
 - 0: OUT2 - Power stage switched OFF
- [5] CMD_OUT3
 - 1: OUT3 - Power stage switched ON
 - 0: OUT3 - Power stage switched OFF
- [4] CMD_OUT4
 - 1: OUT4 - Power stage switched ON
 - 0: OUT4 - Power stage switched OFF
- [3] CMD_OUT5
 - 1: OUT5 - Power stage switched ON
 - 0: OUT5 - Power stage switched OFF
- [2] CMD_OUT20
 - 1: OUT20 - Power stage switched ON
 - 0: OUT20 - Power stage switched OFF
- [1] RESERVED
- [0] RESERVED

CONTR_REG2

Control register 2

7	6	5	4	3	2	1	0
CMD_OUT15	CMD_OUT14	DON'T CARE	RESERVED	CMD_IGN1	CMD_IGN2	CMD_IGN3	CMD_IGN4

Address: 0 1001
Type: Via DATA frame
Reset: 0000 0000 (ALL outputs switched OFF)

- [7] CMD_OUT15
 1: OUT15 - Power stage switched ON
 0: OUT15 - Power stage switched OFF
- [6] CMD_OUT14
 1: OUT14 - Power stage switched ON
 0: OUT14 - Power stage switched OFF
- [5] DON'T CARE
- [4] RESERVED
- [3] CMD_IGN1
 1: IGN1 - Power stage switched ON
 0: IGN1 - Power stage switched OFF
- [2] CMD_IGN2
 1: IGN2 - Power stage switched ON
 0: IGN2 - Power stage switched OFF
- [1] CMD_IGN3
 1: IGN3 - Power stage switched ON
 0: IGN3 - Power stage switched OFF
- [0] CMD_IGN4
 1: IGN4 - Power stage switched ON
 0: IGN4 - Power stage switched OFF

CONTR_REG3

Control register 3

	7	6	5	4	3	2	1	0
CPS_CONF = 0	CMD_OUT22	CMD_OUT21	CMD_OUT16	CMD_OUT13	CMD_OUT17	CMD_OUT18	CMD_OUT7	CMD_OUT6
CPS_CONF = 1	DIR	ENABLE						

Address: 0 1010

Type: Via DATA frame

Reset: 0000 0000 (ALL outputs switched OFF)

- 0 CMD_OUT6
 - 1: OUT6 - Power stage switched ON
 - 0: OUT6 - Power stage switched OFF
- 1 CMD_OUT7
 - 1: OUT7 - Power stage switched ON
 - 0: OUT7 - Power stage switched OFF
- 2 CMD_OUT18
 - 1: OUT18 - Power stage switched ON
 - 0: OUT18 - Power stage switched OFF
- 3 CMD_OUT17
 - 1: OUT17 - Power stage switched ON
 - 0: OUT17 - Power stage switched OFF
- 4 CMD_OUT13
 - 1: OUT13 - Power stage switched ON
 - 0: OUT13 - Power stage switched OFF
- 5 CMD_OUT16
 - 1: OUT16 - Power stage switched ON
 - 0: OUT16 - Power stage switched OFF
- 6 CMD_OUT21
 - 1: OUT21 - Power stage switched ON (High side driver)
 - 0: OUT21 - Power stage switched OFF
 - Note: If CPS_CONF=0 (single power stages configuration)*
 - ENABLE
 - 0: stepper motor driver disabled
 - 1: stepper motor driver enabled
 - Note: If CPS_CONF=1 (stepper motor driving configuration)*
- 7 CMD_OUT22
 - 1: OUT22 - Power stage switched ON
 - Note: If CPS_CONF=0 (single power stages configuration)*
 - 0: OUT22 - Power stage switched OFF
 - DIR
 - 0: forward direction
 - 1: backward direction
 - Note: if CPS_CONF=1 (stepper motor driving configuration)*

Note: The meaning of some CONTR_REG3 bit depends on the configuration of bit CPS_CONF of CONF_REG1.

CONTR_REG4**Control register 4**

	7	6	5	4	3	2	1	0
CPS_CONF = 0	RESERVED		CMD_OUT28	CMD_OUT27	CMD_OUT26	CMD_OUT25	CMD_OUT24	CMD_OUT23
CPS_CONF = 1	RESERVED							PWM

Address: 0 1011**Type:****Reset:** 0000 0000 (ALL outputs switched OFF)

[6-7] RESERVED: NOT used

[5] CMD_OUT28

- 1: OUT28 Power stage switched ON
- 0: OUT28 Power stage switched OFF

[4] CMD_OUT27

- 1: OUT27 Power stage switched ON
- 0: OUT27 Power stage switched OFF

[3] CMD_OUT26

- 1: OUT26 - Power stage switched ON (High side driver)
- 0: OUT26 - Power stage switched OFF

[2] CMD_OUT25

- 1: OUT25 - Power stage switched ON (High side driver)
- 0: OUT25 - Power stage switched OFF

[1] CMD_OUT24

- 1: OUT24 - Power stage switched ON
- 0: OUT24 - Power stage switched OFF

[0] If CPS_CONF=0 (single power stages configuration)

CMD_OUT23

- 1: OUT23 Power stage switched ON
- 0: OUT23 Power stage switched OFF

if CPS_CONF=1 (stepper motor driving configuration)

PWM

- 1 → 0: no step change in the driving sequence
- 0 → 1: step change in the driving sequence (next step applied)

Note: The meaning of some CONTR_REG4 bit depends on the configuration of bit CPS_CONF of CONF_REG1.

7 Package information

In order to meet environmental requirements, ST offers these devices in different grades of ECOPACK® packages, depending on their level of environmental compliance. ECOPACK® specifications, grade definitions and product status are available at: www.st.com.

ECOPACK® is an ST trademark.

7.1 HiQUAD-64 package information

Figure 74. HiQUAD-64 package outline

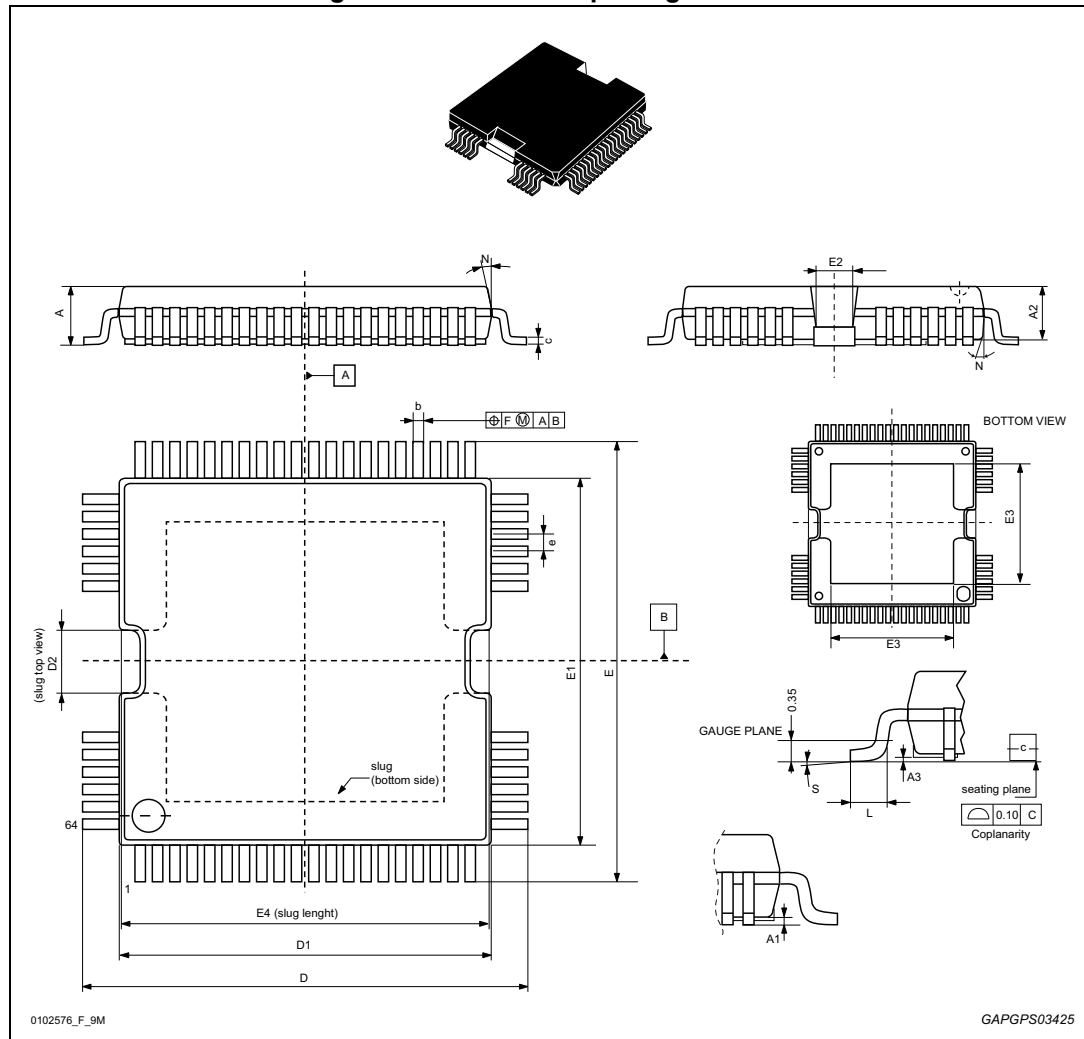

Table 58. HiQUAD-64 package mechanical data

Ref	Dimensions					
	Millimeters			Inches ⁽¹⁾		
	Min.	Typ.	Max.	Min.	Typ.	Max.
A	-	-	3.15	-	-	0.1240
A1	0	-	0.25	0	-	0.0098
A2	2.50	-	2.90	0.0984	-	0.1142
A3	0	-	0.10	0	-	0.0039
b	0.22	-	0.38	0.0087	-	0.0150
c	0.23	-	0.32	0.0091	-	0.0126
D ⁽²⁾	17.00	-	17.40	0.6693	-	0.6850
D1	13.90	14.00	14.10	0.5472	0.5512	0.5551
D2	2.65	2.80	2.95	0.1043	0.1102	0.1161
E	17.00	-	17.40	0.6693	-	0.6850
E1 ⁽¹⁾	13.90	14.00	14.10	0.5472	0.5512	0.5551
E2	2.35	-	2.65	0.0925	-	0.1043
E3	9.30	9.50	9.70	0.3661	0.3740	0.3819
E4	13.30	13.50	13.70	0.5236	0.5315	0.5394
e	-	0.65	-	-	0.0256	-
F	-	0.12	-	-	0.0047	-
G	-	0.10	-	-	0.0039	-
L	0.80	-	1.10	0.0315	-	0.0433
N	-	-	10°	-	-	10°
s	0°	-	7°	0°	-	7°

1. Values in inches are converted from mm and rounded to 4 decimal digits.
2. Dimensions D and E1 do not include mold flash or protrusions. Mold flash or protrusions shall not exceed 0.15mm (.006inc.).

8 Revision history

Table 59. Document revision history

Date	Revision	Changes
08-Apr-2015	1	Initial release.
08-May-2015	2	Updated Table 30 , 31 , 32 and 33 for the pins OUTA/B/C/D (High-side) the “Ron max” value is changed in 1.7 Ω .

IMPORTANT NOTICE – PLEASE READ CAREFULLY

STMicroelectronics NV and its subsidiaries ("ST") reserve the right to make changes, corrections, enhancements, modifications, and improvements to ST products and/or to this document at any time without notice. Purchasers should obtain the latest relevant information on ST products before placing orders. ST products are sold pursuant to ST's terms and conditions of sale in place at the time of order acknowledgement.

Purchasers are solely responsible for the choice, selection, and use of ST products and ST assumes no liability for application assistance or the design of Purchasers' products.

No license, express or implied, to any intellectual property right is granted by ST herein.

Resale of ST products with provisions different from the information set forth herein shall void any warranty granted by ST for such product.

ST and the ST logo are trademarks of ST. All other product or service names are the property of their respective owners.

Information in this document supersedes and replaces information previously supplied in any prior versions of this document.

© 2015 STMicroelectronics – All rights reserved

