

|     |      |           |     |               |         |     |      |
|-----|------|-----------|-----|---------------|---------|-----|------|
| LOC | DIST | REVISIONS |     |               |         |     |      |
| CM  | 53   | P         | LTR | DESCRIPTION   | DATE    | DWN | APVD |
|     |      | B         |     | ECO-07-027216 | 16NOV07 | KW  | CC   |

1. TO BE USED WITH APPROPRIATE .156 MATE-N-LOK™ PINS.
2. DIMENSIONS IN BRACKETS ARE IN INCHES.

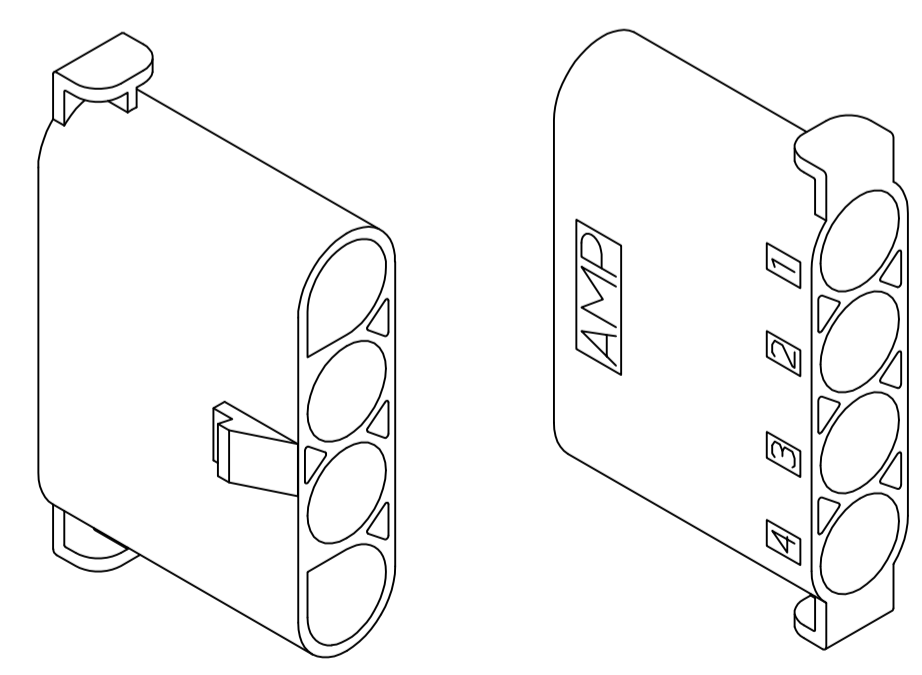
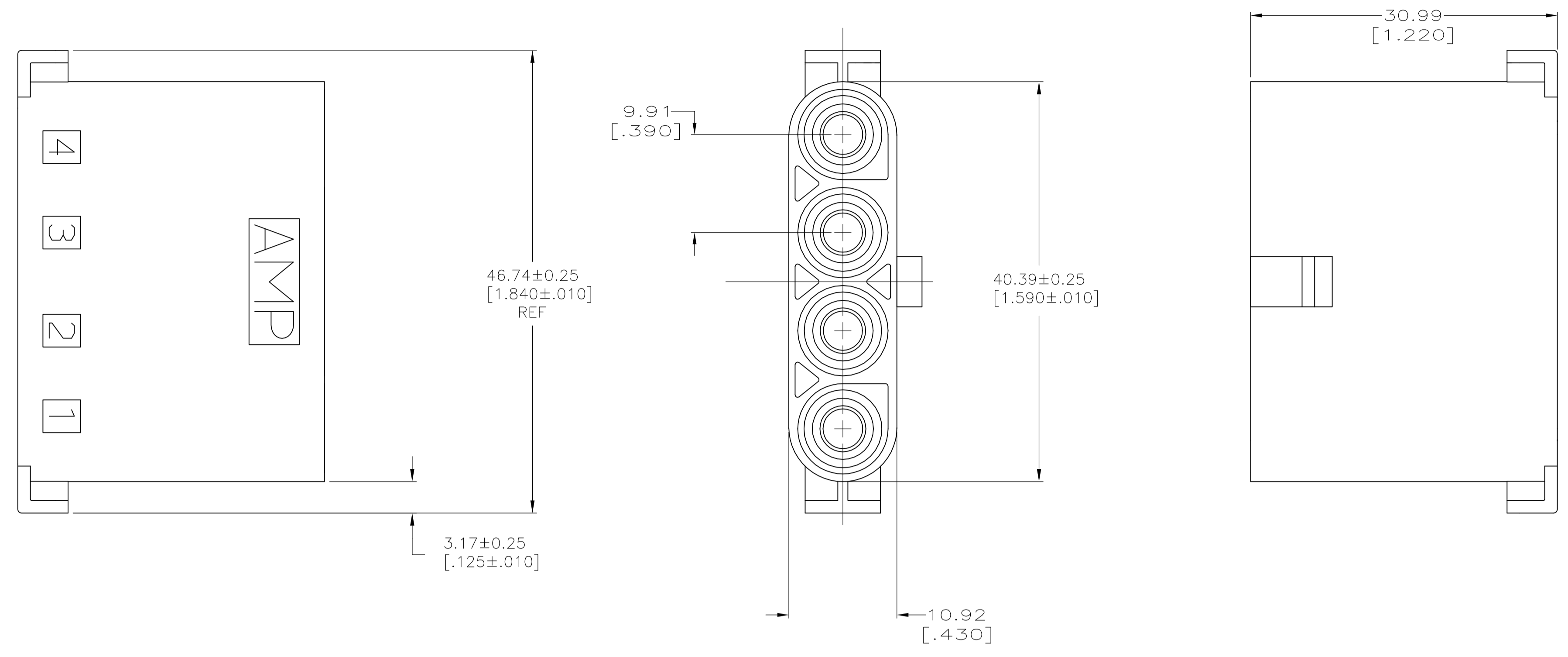

3-DIMENSIONAL MODEL VIEWS

794117-1  
PART NUMBER

METRIC

|  |  |                  |         |  |  |
|--|--|------------------|---------|--|--|
| THIS DRAWING IS A CONTROLLED DOCUMENT. |  | DIN              | 4-19-96 | Tyco Electronics Corporation           |  |
|  |  | CHK              | 4-19-96 | Harrisburg, PA 17105-3608              |  |
|  |  | APVD             | 4-30-96 | NAME                                   |  |
|  |  | PRODUCT SPEC     |         | CAP, 4 CIRCUIT,<br>.156 MATE-N-LOK(TM) |  |
|  |  | APPLICATION SPEC |         | RESTRICTED TO                          |  |
|  |  | WEIGHT           |         | SCALE 3:1 SHEET 1 OF 1 REV B           |  |
|  |  | CUSTOMER DRAWING |         | A1 00779 C=794117                      |  |