

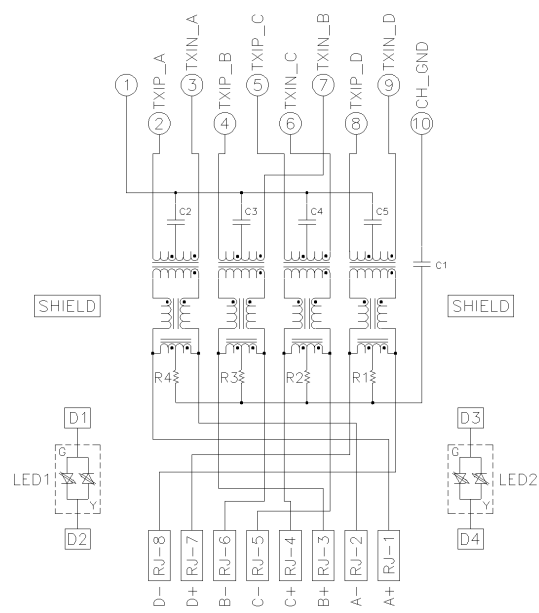

**7G07 SERIES GIGABIT CIRCUIT**

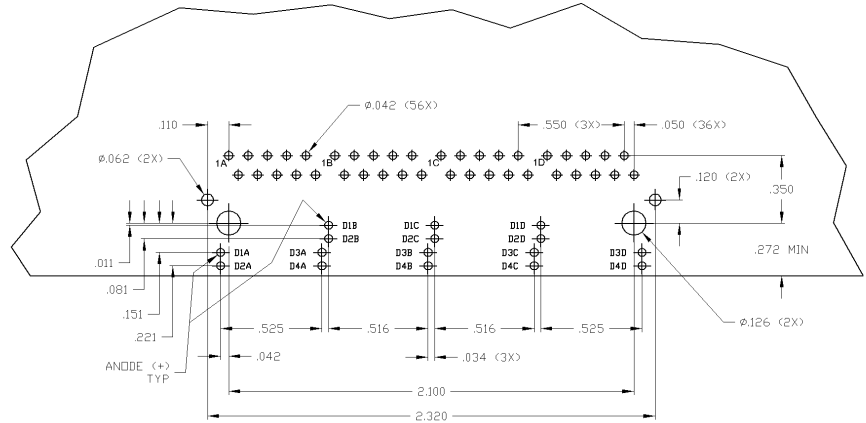

C1 = 1000pF, 2kV CAPACITOR  
 R1-R4 = 75 OHMS, 1/16W RESISTORS  
 C2-C5 = 0.1µF, 50V CAPACITORS

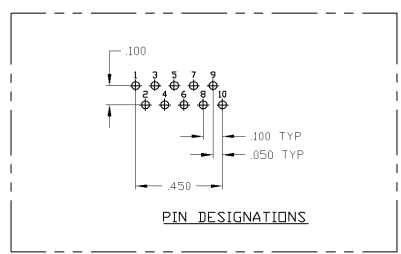

**SUGGESTED PCB LAYOUT**  
(Component Side)

THIS DRAWING IS A CONTROLLED DOCUMENT.		REV. CONTROLLED	ISSUED BY	DATE	REVISIONS
DATE	BY	APP'D	CHK'D	REV	DATE
0	0	0	0	0	0
1	1	1	1	1	1
2	2	2	2	2	2
3	3	3	3	3	3
4	4	4	4	4	4
5	5	5	5	5	5
6	6	6	6	6	6
7	7	7	7	7	7
8	8	8	8	8	8
9	9	9	9	9	9
10	10	10	10	10	10
11	11	11	11	11	11
12	12	12	12	12	12
13	13	13	13	13	13
14	14	14	14	14	14
15	15	15	15	15	15
16	16	16	16	16	16
17	17	17	17	17	17
18	18	18	18	18	18
19	19	19	19	19	19
20	20	20	20	20	20
21	21	21	21	21	21
22	22	22	22	22	22
23	23	23	23	23	23
24	24	24	24	24	24
25	25	25	25	25	25
26	26	26	26	26	26
27	27	27	27	27	27
28	28	28	28	28	28
29	29	29	29	29	29
30	30	30	30	30	30
31	31	31	31	31	31
32	32	32	32	32	32
33	33	33	33	33	33
34	34	34	34	34	34
35	35	35	35	35	35
36	36	36	36	36	36
37	37	37	37	37	37
38	38	38	38	38	38
39	39	39	39	39	39
40	40	40	40	40	40
41	41	41	41	41	41
42	42	42	42	42	42
43	43	43	43	43	43
44	44	44	44	44	44
45	45	45	45	45	45
46	46	46	46	46	46
47	47	47	47	47	47
48	48	48	48	48	48
49	49	49	49	49	49
50	50	50	50	50	50
51	51	51	51	51	51
52	52	52	52	52	52
53	53	53	53	53	53
54	54	54	54	54	54
55	55	55	55	55	55
56	56	56	56	56	56
57	57	57	57	57	57
58	58	58	58	58	58
59	59	59	59	59	59
60	60	60	60	60	60
61	61	61	61	61	61
62	62	62	62	62	62
63	63	63	63	63	63
64	64	64	64	64	64
65	65	65	65	65	65
66	66	66	66	66	66
67	67	67	67	67	67
68	68	68	68	68	68
69	69	69	69	69	69
70	70	70	70	70	70
71	71	71	71	71	71
72	72	72	72	72	72
73	73	73	73	73	73
74	74	74	74	74	74
75	75	75	75	75	75
76	76	76	76	76	76
77	77	77	77	77	77
78	78	78	78	78	78
79	79	79	79	79	79
80	80	80	80	80	80
81	81	81	81	81	81
82	82	82	82	82	82
83	83	83	83	83	83
84	84	84	84	84	84
85	85	85	85	85	85
86	86	86	86	86	86
87	87	87	87	87	87
88	88	88	88	88	88
89	89	89	89	89	89
90	90	90	90	90	90
91	91	91	91	91	91
92	92	92	92	92	92
93	93	93	93	93	93
94	94	94	94	94	94
95	95	95	95	95	95
96	96	96	96	96	96
97	97	97	97	97	97
98	98	98	98	98	98
99	99	99	99	99	99
100	100	100	100	100	100