

APPROVED: _____
 DATE: _____ TITLE: _____

Rev	AWO #	Description	Date	Appr
-		RELEASED	11/1/22	
A		UPDATE SPEC.	11/30/22	JJ/RC

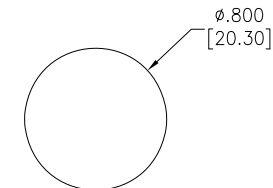
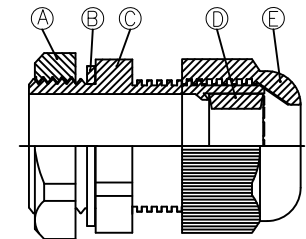
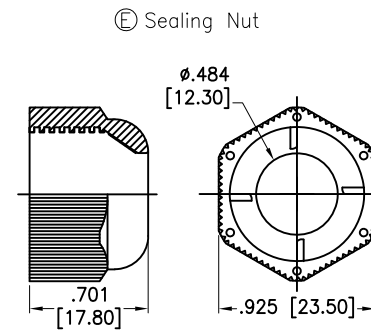
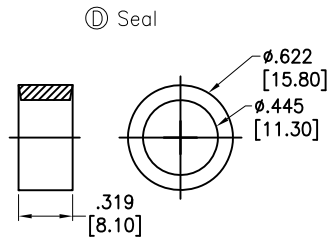
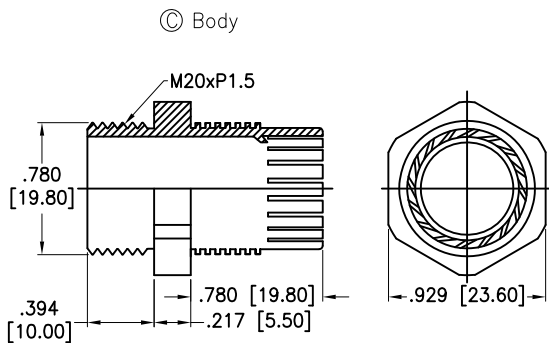
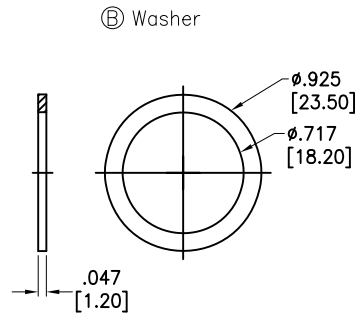
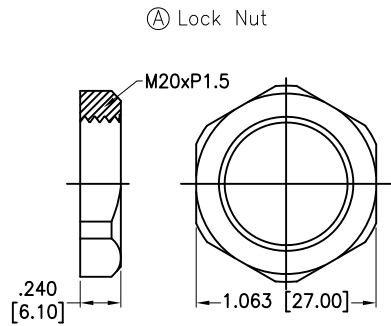

RECOMMENDED
 PANEL CUT-OUT
 (.106 [2.7] MAX PANEL THICKNESS)

SPECIFICATIONS:

Material:

Lock Nut: PA66, rated UL 94V-2

Body: PA66, rated UL 94V-2

Sealing Nut: PA66, rated UL 94V-2

Washer: Nitrile Butylene

Seal: Nitrile Butylene

Mechanical:

Cable range O.D.: ϕ .236~ ϕ .433 [6.00~11.00mm]

Nut Torque: 2Nm Max.

Environmental:

Waterproof: IP68

Lead free, RoHS compliant.



UNLESS OTHERWISE SPECIFIED ALL DIMENSIONS ARE INCHES [MM]. TOLERANCES: EXCEPT AS NOTED

INCHES		HOLES	
.X	± .10	Ø.X	± .10
.XX	± .020	Ø.XX	± .015
.XXX	± .015	Ø.XXX	± .010



909 Rahway Avenue,
 Union, NJ 07083
 Phone: 908-687-5000
 Fax: 908-687-5710

DRAWN	JJ	11/1/22
CHECKED	RC	11/1/22
APPROVED		

TITLE		
WATERPROOF CONNECTOR, M20, 1 HOLE, CABLE GLAND, WATERPROOF: IP68		

THIS DRAWING CONTAINS INFORMATION THAT IS PROPRIETARY AND SHOULD NOT BE USED WITHOUT PRIOR WRITTEN PERMISSION FROM ADAM TECH

SIZE	PART NO.	REV.
X	CG-P-M20	A
REF: S00211C	SCALE: NTS	SHEET 1 OF 1