

1

2

3

4

5

6

7

Signature	Revision History	Date	Rev.
Sean	For Bulk Production	FEB,27,2013	01

RoHS Compliant

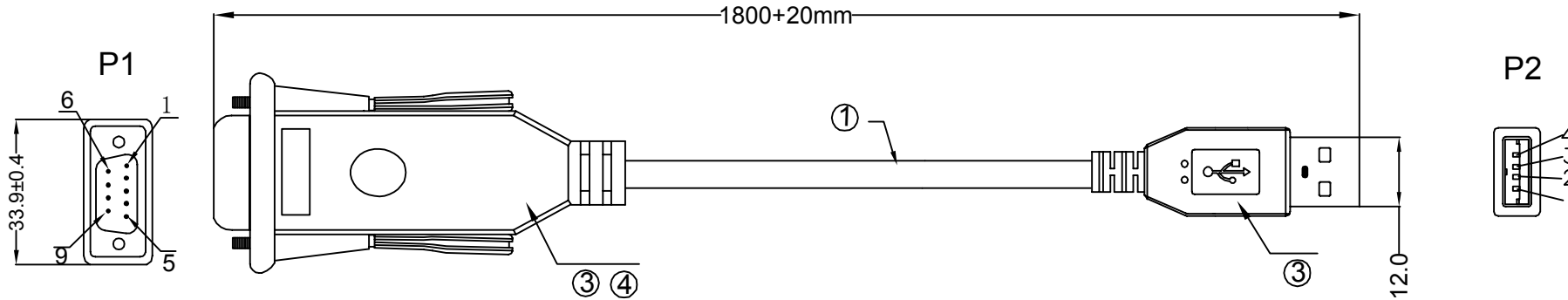

NOTES:

1.CABLE: UL 2725 USB CABLE #28\*4C+28 OD:4.5MM COLOR: BLACK

2.CONNECTOR:

P1 : D-SUB 9PIN MALE, HSG COLOR: BLUE / Thumbscrew ( 4#40)

P2 : USB A TYPE MALE , SOLDER, WHITE INSULATION, GOLD PLATED CONTACTS, NICKEL PLATED SHELL

3.HOOD: MOLDED TYPE,PVC 45P,COLOR:BLACK.

4.PCBA: Bonding

5.ELECTRICLE TEST:

(1)100% OPEN SHORT & MIS WIRE TEST.

(2)CONTACT RESISTANCE 3 ohm Max .

(3)INSULATION RESISTANCE 10M ohm Min .

(4)HI-POT TEST:DC 300V/10ms

PIN ASSIGNMENT	
P1(PCB)	P2
1 ——— RED ———	1
2 ——— WHITE ———	2
3 ——— GREEN ———	3
5 ——— BLACK ———	4

	Date	Name
Drawn by	FEB,27,2013	Sean
Checked by	FEB,27,2013	Joe
Approved by	FEB,27,2013	Andy

Part No.  
**DA-70119**  
 EAN:4016032117940

**ASSMANN**  
 Electronic GmbH

Title  
 D-SUB 9Pin Male TO USB A/M CABLE  
 D-SUB 9PIN FEMALE TO D-SUB 25PIN MALE Adapter

Scale	N/A	Sheet
Unit	MM	1/3

STxxxxx

1

2

3

4

5

6

7

1

2

3

4

5

6

7

Signature	Revision History	Date	Rev.
Sean	For Bulk Production	FEB,27,2013	01

RoHS Compliant

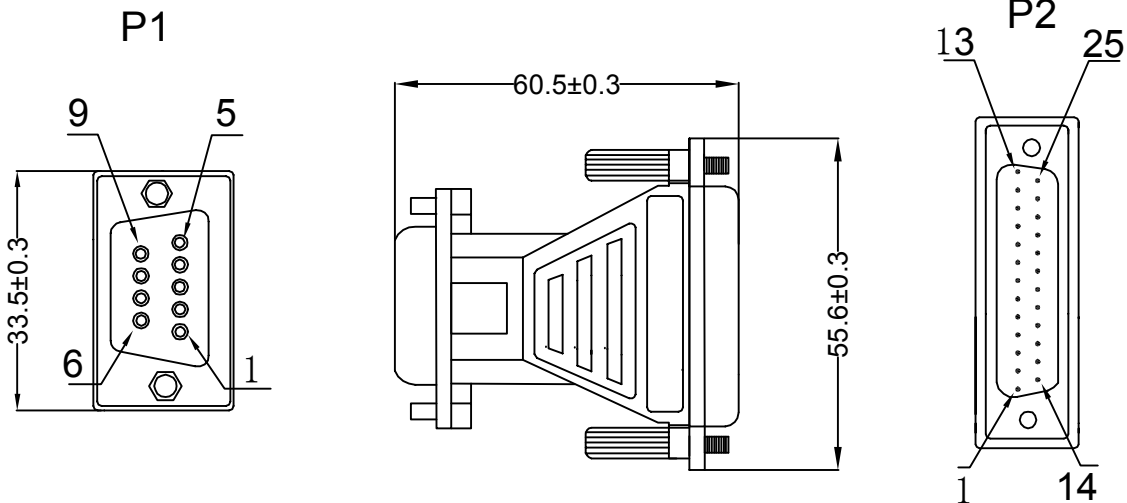

PIN ASSIGNMENT		
P1		P2
1	_____	8
2	_____	3
3	_____	2
4	_____	20
5	_____	7
6	_____	6
7	_____	4
8	_____	5
9	_____	22

NOTES:

1.CONNECTOR:

P1 : D-SUB 9PIN FEMALE, HSG COLOR: BLUE

P2 : D-SUB 25PIN MALE, HSG COLOR: BLUE / Thumbscrew ( 4#40)

3.HOOD: MOLDED TYPE,PVC 45P,COLOR:BLACK.

4.PCBA: Bonding

5.ELECTRICLE TEST:

(1)100% OPEN SHORT & MIS WIRE TEST.

	Date	Name
Drawn by	FEB,27,2013	Sean
Checked by	FEB,27,2013	Joe
Approved by	FEB,27,2013	Andy

Part No.

DA-70119

EAN:4016032117940

Title

D-SUB 9Pin Male TO USB A/M CABLE  
D-SUB 9PIN FEMALE TO D-SUB 25PIN MALE Adapter

Scale	N/A	Sheet
Unit	MM	2/3

ASSMANN  
Electronic GmbH

STxxxxx

1

2

3

4

5

6

7

1

2

3

4

5

6

7

# Package Details

**RoHS Compliant**

Signature	Revision History	Date	Rev.
Sean	For Bulk Production	FEB,27,2013	01

A

A

## Single Cable

P/N	Cable Length	Rolling Size (Single Cable)	Bag Size (Single Cable)	Article Weight (Single Cable)
DA-70119	1.8m	mm max.	mm	0.166g

B

B

## Inner Packing Unit

P/N	Cable Length	Quantity (Inner Packing Unit)	Type (Inner Packing Unit)	Size (Inner Packing Unit)	Weight (Inner Packing Unit)
DA-70119	--	--	--	-- mm	-- kg

C

C

D

D

## CARTON DETAILS

P/N	Cable Length	Quantity (Carton)	Measurement (Carton)	N.W. (Carton)	N.W. (Carton)
DA-70119	1.8m	24pcs	40*30*30CM	4.0kg	5.0kg

E

E

F

F

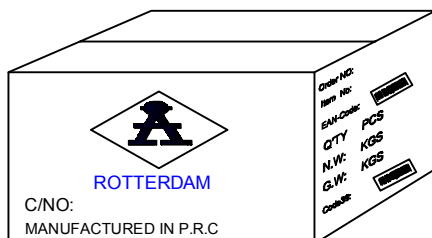

G

G

H

H

- \* "ROTTERDAM" is for Sea Freight shipment
- \* "COLOGNE" is for Air Freight shipment
- \* "LUDENSCHIED" is for Fedex or UPS shipment



		Date	Name	Part No.  <b>DA-70119</b>  EAN:4016032117940
Drawn by	FEB,27,2013	Sean		
Checked by	FEB,27,2013	Joe		
Approved by	FEB,27,2013	Andy		
<b>ASSMANN</b> Electronic GmbH				Title D-SUB 9Pin Male TO USB A/M CABLE D-SUB 9PIN FEMALE TO D-SUB 25PIN MALE Adapter
				Scale Unit

1

2

3

4

5

6

7