

MC74HC4051A, MC74HC4052A, MC74HC4053A



ON Semiconductor®

www.onsemi.com

Analog Multiplexers/ Demultiplexers

High-Performance Silicon-Gate CMOS

The MC74HC4051A, MC74HC4052A and MC74HC4053A utilize silicon-gate CMOS technology to achieve fast propagation delays, low ON resistances, and low OFF leakage currents. These analog multiplexers/demultiplexers control analog voltages that may vary across the complete power supply range (from V_{CC} to V_{EE}).

The HC4051A, HC4052A and HC4053A are identical in pinout to the metal-gate MC14051AB, MC14052AB and MC14053AB. The Channel-Select inputs determine which one of the Analog Inputs/Outputs is to be connected, by means of an analog switch, to the Common Output/Input. When the Enable pin is HIGH, all analog switches are turned off.

The Channel-Select and Enable inputs are compatible with standard CMOS outputs; with pullup resistors they are compatible with LSTTL outputs.

These devices have been designed so that the ON resistance (R_{on}) is more linear over input voltage than R_{on} of metal-gate CMOS analog switches.

For a multiplexer/demultiplexer with injection current protection, see HC4851A and HC4852A.

Features

- Fast Switching and Propagation Speeds
- Low Crosstalk Between Switches
- Diode Protection on All Inputs/Outputs
- Analog Power Supply Range ($V_{CC} - V_{EE}$) = 2.0 to 12.0 V
- Digital (Control) Power Supply Range ($V_{CC} - GND$) = 2.0 to 6.0 V
- Improved Linearity and Lower ON Resistance Than Metal-Gate Counterparts
- Low Noise
- In Compliance with the Requirements of JEDEC Standard No. 7A
- Chip Complexity: HC4051A – 184 FETs or 46 Equivalent Gates
HC4052A – 168 FETs or 42 Equivalent Gates
HC4053A – 156 FETs or 39 Equivalent Gates
- NLV Prefix for Automotive and Other Applications Requiring Unique Site and Control Change Requirements; AEC-Q100 Qualified and PPAP Capable
- These Devices are Pb-Free, Halogen Free/BFR-Free and are RoHS Compliant

This document contains information on some products that are still under development. ON Semiconductor reserves the right to change or discontinue these products without notice.

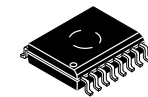

SOIC-16 WIDE
DW SUFFIX
CASE 751G

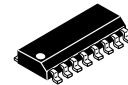

SOIC-16
D SUFFIX
CASE 751B

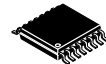

TSSOP-16
DT SUFFIX
CASE 948F



QFN16
MN SUFFIX
CASE 485AW

MARKING DIAGRAMS

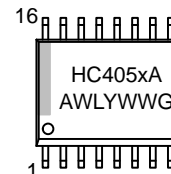

SOIC-16 WIDE

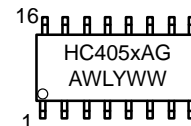

SOIC-16

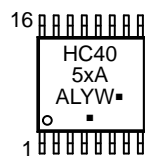

TSSOP-16

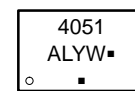

QFN16

x = 1, 2 or 3
A = Assembly Location
WL, L = Wafer Lot
YY, Y = Year
WW, W = Work Week
G or ■ = Pb-Free Package

(Note: Microdot may be in either location)

ORDERING INFORMATION

See detailed ordering and shipping information in the package dimensions section on page 13 of this data sheet.

MC74HC4051A, MC74HC4052A, MC74HC4053A

**LOGIC DIAGRAM
MC74HC4051A
Single-Pole, 8-Position Plus Common Off**

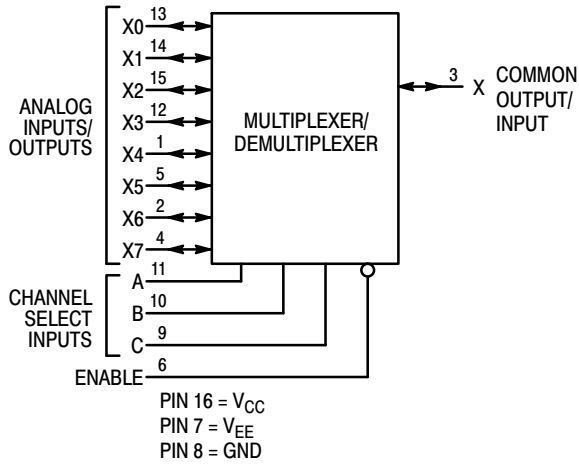

FUNCTION TABLE – MC74HC4051A

| Control Inputs | | ON Channels | | |
|----------------|--------|-------------|---|------|
| Enable | Select | | | |
| | C | B | A | |
| L | L | L | L | X0 |
| L | L | L | H | X1 |
| L | L | H | L | X2 |
| L | L | H | H | X3 |
| L | H | L | L | X4 |
| L | H | L | H | X5 |
| L | H | H | L | X6 |
| L | H | H | H | X7 |
| H | X | X | X | NONE |

X = Don't Care

Pinout: MC74HC4051A (Top View)

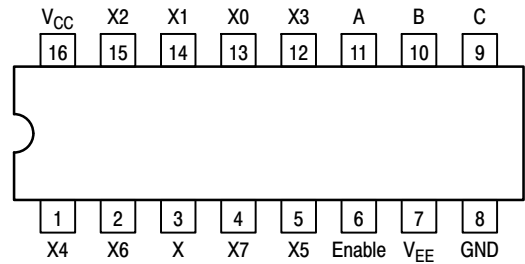

**LOGIC DIAGRAM
MC74HC4052A
Double-Pole, 4-Position Plus Common Off**

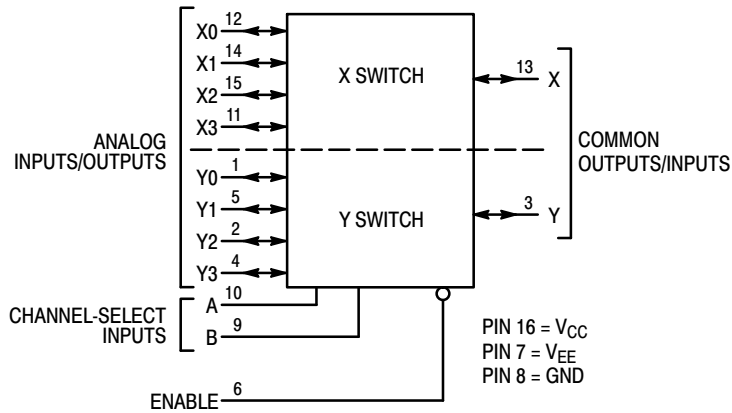

FUNCTION TABLE – MC74HC4052A

| Control Inputs | | ON Channels | |
|----------------|--------|-------------|-------|
| Enable | Select | | |
| | B | A | |
| L | L | L | Y0 X0 |
| L | L | H | Y1 X1 |
| L | H | L | Y2 X2 |
| L | H | H | Y3 X3 |
| H | X | X | NONE |

X = Don't Care

Pinout: MC74HC4052A (Top View)

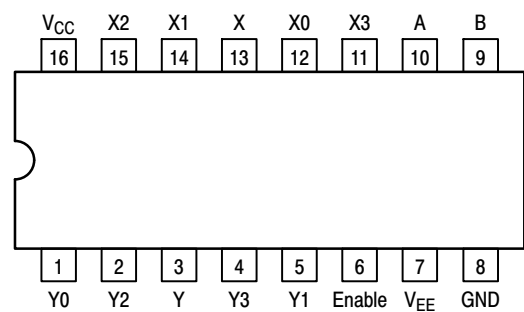

MC74HC4051A, MC74HC4052A, MC74HC4053A

FUNCTION TABLE – MC74HC4053A

LOGIC DIAGRAM
MC74HC4053A
Triple Single-Pole, Double-Position Plus Common Off

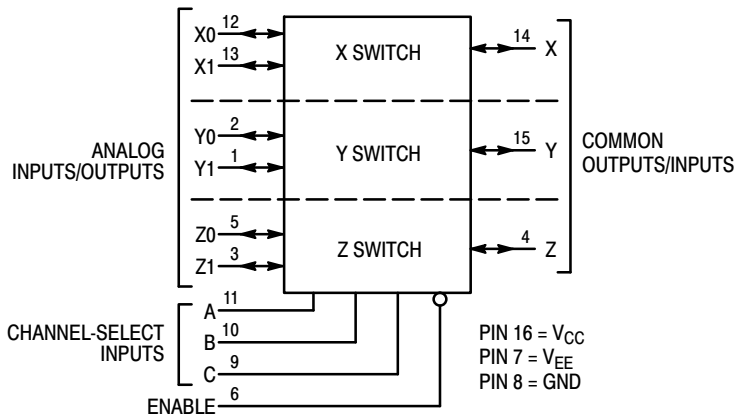

NOTE: This device allows independent control of each switch. Channel-Select Input A controls the X-Switch, Input B controls the Y-Switch and Input C controls the Z-Switch

| Control Inputs | | ON Channels | | | |
|----------------|--------|-------------|---|---|----------|
| Enable | Select | C | B | A | |
| L | L | L | L | L | Z0 Y0 X0 |
| L | L | L | L | H | Z0 Y0 X1 |
| L | L | L | H | L | Z0 Y1 X0 |
| L | L | L | H | H | Z0 Y1 X1 |
| L | H | L | L | L | Z1 Y0 X0 |
| L | H | L | L | H | Z1 Y0 X1 |
| L | H | H | L | L | Z1 Y1 X0 |
| L | H | H | L | H | Z1 Y1 X1 |
| H | X | X | X | X | NONE |

X = Don't Care

Pinout: MC74HC4053A (Top View)

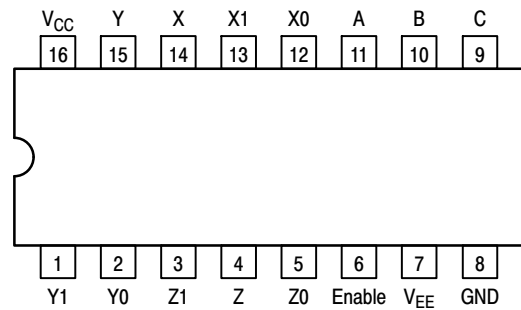

MAXIMUM RATINGS

| Symbol | Parameter | Value | Unit |
|------------------|------------------------------------------------------------------------------------|------------------------------------------------|------|
| V _{CC} | Positive DC Supply Voltage (Referenced to GND) (Referenced to V _{EE}) | -0.5 to +7.0 -0.5 to +14.0 | V |
| V _{EE} | Negative DC Supply Voltage (Referenced to GND) | -7.0 to +5.0 | V |
| V _{IS} | Analog Input Voltage | V _{EE} - 0.5 to V _{CC} + 0.5 | V |
| V _{in} | Digital Input Voltage (Referenced to GND) | -0.5 to V _{CC} + 0.5 | V |
| I | DC Current, Into or Out of Any Pin | ±25 | mA |
| P _D | Power Dissipation in Still Air, SOIC Package† TSSOP Package† | 500 450 | mW |
| T _{stg} | Storage Temperature Range | -65 to +150 | °C |
| T _L | Lead Temperature, 1 mm from Case for 10 Seconds SOIC or TSSOP Package | 260 | °C |

This device contains protection circuitry to guard against damage due to high static voltages or electric fields. However, precautions must be taken to avoid applications of any voltage higher than maximum rated voltages to this high-impedance circuit. For proper operation, V_{in} and V_{out} should be constrained to the range GND ≤ (V_{in} or V_{out}) ≤ V_{CC}. Unused inputs must always be tied to an appropriate logic voltage level (e.g., either GND or V_{CC}). Unused outputs must be left open.

Stresses exceeding those listed in the Maximum Ratings table may damage the device. If any of these limits are exceeded, device functionality should not be assumed, damage may occur and reliability may be affected.

†Derating: SOIC Package: -7 mW/°C from 65° to 125°C
TSSOP Package: -6.1 mW/°C from 65° to 125°C

MC74HC4051A, MC74HC4052A, MC74HC4053A

RECOMMENDED OPERATING CONDITIONS

| Symbol | Parameter | Min | Max | Unit | |
|------------|--------------------------------------------------------------------------------|----------------------------------------------------------------------------------------------------------|------------------|---------------------------|----|
| V_{CC} | Positive DC Supply Voltage (Referenced to GND) (Referenced to V_{EE}) | 2.0 2.0 | 6.0 12.0 | V | |
| V_{EE} | Negative DC Supply Voltage, Output (Referenced to GND) | -6.0 | GND | V | |
| V_{IS} | Analog Input Voltage | V_{EE} | V_{CC} | V | |
| V_{in} | Digital Input Voltage (Referenced to GND) | GND | V_{CC} | V | |
| V_{IO}^* | Static or Dynamic Voltage Across Switch | | 1.2 | V | |
| T_A | Operating Temperature Range, All Package Types | -55 | +125 | °C | |
| t_r, t_f | Input Rise/Fall Time (Channel Select or Enable Inputs) | $V_{CC} = 2.0\text{ V}$ $V_{CC} = 3.0\text{ V}$ $V_{CC} = 4.5\text{ V}$ $V_{CC} = 6.0\text{ V}$ | 0 0 0 0 | 1000 600 500 400 | ns |

Functional operation above the stresses listed in the Recommended Operating Ranges is not implied. Extended exposure to stresses beyond the Recommended Operating Ranges limits may affect device reliability.

*For voltage drops across switch greater than 1.2 V (switch on), excessive V_{CC} current may be drawn; i.e., the current out of the switch may contain both V_{CC} and switch input components. The reliability of the device will be unaffected unless the Maximum Ratings are exceeded.

DC CHARACTERISTICS — Digital Section (Voltages Referenced to GND) $V_{EE} = \text{GND}$, Except Where Noted

| Symbol | Parameter | Condition | V_{CC} V | Guaranteed Limit | | | Unit |
|----------|----------------------------------------------------------------------|------------------------------------------------------------------------------------------------------------------------|---------------|------------------|-------|--------|------|
| | | | | -55 to 25°C | ≤85°C | ≤125°C | |
| V_{IH} | Minimum High-Level Input Voltage, Channel-Select or Enable Inputs | $R_{on} = \text{Per Spec}$ | 2.0 | 1.50 | 1.50 | 1.50 | V |
| | | | 3.0 | 2.10 | 2.10 | 2.10 | |
| | | | 4.5 | 3.15 | 3.15 | 3.15 | |
| | | | 6.0 | 4.20 | 4.20 | 4.20 | |
| V_{IL} | Maximum Low-Level Input Voltage, Channel-Select or Enable Inputs | $R_{on} = \text{Per Spec}$ | 2.0 | 0.5 | 0.5 | 0.5 | V |
| | | | 3.0 | 0.9 | 0.9 | 0.9 | |
| | | | 4.5 | 1.35 | 1.35 | 1.35 | |
| | | | 6.0 | 1.8 | 1.8 | 1.8 | |
| I_{in} | Maximum Input Leakage Current, Channel-Select or Enable Inputs | $V_{in} = V_{CC}$ or GND, $V_{EE} = -6.0\text{ V}$ | 6.0 | ± 0.1 | ± 1.0 | ± 1.0 | μA |
| I_{CC} | Maximum Quiescent Supply Current (per Package) | Channel Select, Enable and $V_{IS} = V_{CC}$ or GND; $V_{EE} = \text{GND}$ $V_{IO} = 0\text{ V}$ $V_{EE} = -6.0$ | 6.0 | 1 | 10 | 20 | μA |
| | | | 6.0 | 4 | 40 | 80 | |

MC74HC4051A, MC74HC4052A, MC74HC4053A

DC CHARACTERISTICS — Analog Section

| Symbol | Parameter | Condition | V _{CC} | V _{EE} | Guaranteed Limit | | | Unit |
|------------------|------------------------------------------------------------------------------------|-----------------------------------------------------------------------------------------------------------------------------------------------------------------|-------------------|-------------------------|-------------------|-------------------|-------------------|------|
| | | | | | -55 to 25°C | ≤85°C | ≤125°C | |
| R _{on} | Maximum "ON" Resistance | V _{in} = V _{IL} or V _{IH} ; V _{IS} = V _{CC} to V _{EE} ; I _S ≤ 2.0 mA (Figures 1, 2) | 4.5 4.5 6.0 | 0.0 - 4.5 - 6.0 | 190 120 100 | 240 150 125 | 280 170 140 | Ω |
| | | V _{in} = V _{IL} or V _{IH} ; V _{IS} = V _{CC} or V _{EE} (Endpoints); I _S ≤ 2.0 mA (Figures 1, 2) | 4.5 4.5 6.0 | 0.0 - 4.5 - 6.0 | 150 100 80 | 190 125 100 | 230 140 115 | |
| ΔR _{on} | Maximum Difference in "ON" Resistance Between Any Two Channels in the Same Package | V _{in} = V _{IL} or V _{IH} ; V _{IS} = 1/2 (V _{CC} - V _{EE}); I _S ≤ 2.0 mA | 4.5 4.5 6.0 | 0.0 - 4.5 - 6.0 | 30 12 10 | 35 15 12 | 40 18 14 | Ω |
| I _{off} | Maximum Off-Channel Leakage Current, Any One Channel | V _{in} = V _{IL} or V _{IH} ; V _{IO} = V _{CC} - V _{EE} ; Switch Off (Figure 3) | 6.0 | - 6.0 | 0.1 | 0.5 | 1.0 | μA |
| | Maximum Off-Channel Leakage Current, Common Channel | V _{in} = V _{IL} or V _{IH} ; V _{IO} = V _{CC} - V _{EE} ; Switch Off (Figure 4) | 6.0 6.0 6.0 | - 6.0 - 6.0 - 6.0 | 0.2 0.1 0.1 | 2.0 1.0 1.0 | 4.0 2.0 2.0 | |
| I _{on} | Maximum On-Channel Leakage Current, Channel-to-Channel | HC4051A | 6.0 | - 6.0 | 0.2 | 2.0 | 4.0 | μA |
| | | HC4052A | 6.0 | - 6.0 | 0.1 | 1.0 | 2.0 | |
| | | HC4053A | 6.0 | - 6.0 | 0.1 | 1.0 | 2.0 | |

AC CHARACTERISTICS (C_L = 50 pF, Input t_r = t_f = 6 ns)

| Symbol | Parameter | V _{CC} V | Guaranteed Limit | | | Unit | |
|----------------------------------------|-----------------------------------------------------------------------|----------------------------------------------------------------|------------------|-------|--------|------|----|
| | | | -55 to 25°C | ≤85°C | ≤125°C | | |
| t _{PLH} , t _{PHL} | Maximum Propagation Delay, Channel-Select to Analog Output (Figure 9) | 2.0 | 270 | 320 | 350 | ns | |
| | | 3.0 | 90 | 110 | 125 | | |
| | | 4.5 | 59 | 79 | 85 | | |
| | | 6.0 | 45 | 65 | 75 | | |
| t _{PLH} , t _{PHL} | Maximum Propagation Delay, Analog Input to Analog Output (Figure 10) | 2.0 | 40 | 60 | 70 | ns | |
| | | 3.0 | 25 | 30 | 32 | | |
| | | 4.5 | 12 | 15 | 18 | | |
| | | 6.0 | 10 | 13 | 15 | | |
| t _{PZL} , t _{PHZ} | Maximum Propagation Delay, Enable to Analog Output (Figure 11) | 2.0 | 160 | 200 | 220 | ns | |
| | | 3.0 | 70 | 95 | 110 | | |
| | | 4.5 | 48 | 63 | 76 | | |
| | | 6.0 | 39 | 55 | 63 | | |
| t _{PZL} , t _{PZH} | Maximum Propagation Delay, Enable to Analog Output (Figure 11) | 2.0 | 245 | 315 | 345 | ns | |
| | | 3.0 | 115 | 145 | 155 | | |
| | | 4.5 | 49 | 69 | 83 | | |
| | | 6.0 | 39 | 58 | 67 | | |
| C _{in} | Maximum Input Capacitance, Channel-Select or Enable Inputs | | 10 | 10 | 10 | pF | |
| C _{I/O} | Maximum Capacitance (All Switches Off) | Analog I/O | | 35 | 35 | 35 | pF |
| | | Common O/I: HC4051A | | 130 | 130 | 130 | |
| | | HC4052A | | 80 | 80 | 80 | |
| | | HC4053A | | 50 | 50 | 50 | |
| | Feed-through | | 1.0 | 1.0 | 1.0 | | |
| C _{PD} | Power Dissipation Capacitance (Figure 13)* | Typical @ 25°C, V _{CC} = 5.0 V, V _{EE} = 0 V | | | pF | | |
| | | HC4051A | 45 | | | | |
| | HC4052A | 80 | | | | | |
| | HC4053A | 45 | | | | | |

* Used to determine the no-load dynamic power consumption: P_D = C_{PD} V_{CC}²f + I_{CC} V_{CC}.

MC74HC4051A, MC74HC4052A, MC74HC4053A

ADDITIONAL APPLICATION CHARACTERISTICS (GND = 0 V)

| Symbol | Parameter | Condition | V _{CC} V | V _{EE} V | Limit* | | | Unit |
|--------|---------------------------------------------------------------------------------|----------------------------------------------------------------------------------------------------------------------------------------------------------------------------------------------------------------|----------------------|----------------------|--------|-----|-----|------------------|
| | | | | | 25°C | | | |
| BW | Maximum On-Channel Bandwidth or Minimum Frequency Response (Figure 6) | f _{in} = 1MHz Sine Wave; Adjust f _{in} Voltage to Obtain 0dBm at V _{OS} ; Increase f _{in} Frequency Until dB Meter Reads -3dB; R _L = 50Ω, C _L = 10pF | 2.25 | -2.25 | '51 | '52 | '53 | MHz |
| | | | 4.50 | -4.50 | 80 | 95 | 120 | |
| | | | 6.00 | -6.00 | 80 | 95 | 120 | |
| - | Off-Channel Feed-through Isolation (Figure 7) | f _{in} = Sine Wave; Adjust f _{in} Voltage to Obtain 0dBm at V _{IS} f _{in} = 10kHz, R _L = 600Ω, C _L = 50pF | 2.25 | -2.25 | -50 | | | dB |
| | | 4.50 | -4.50 | -50 | | | | |
| - | Feedthrough Noise. Channel-Select Input to Common I/O (Figure 8) | V _{in} ≤ 1MHz Square Wave (t _r = t _f = 6ns); Adjust R _L at Setup so that I _S = 0A; Enable = GND R _L = 600Ω, C _L = 50pF | 2.25 | -2.25 | 25 | | | mV _{PP} |
| | | 4.50 | -4.50 | 105 | | | | |
| - | Crosstalk Between Any Two Switches (Figure 12) (Test does not apply to HC4051A) | f _{in} = Sine Wave; Adjust f _{in} Voltage to Obtain 0dBm at V _{IS} f _{in} = 10kHz, R _L = 600Ω, C _L = 50pF | 2.25 | -2.25 | -50 | | | dB |
| | | 4.50 | -4.50 | -50 | | | | |
| - | Crosstalk Between Any Two Switches (Figure 12) (Test does not apply to HC4051A) | f _{in} = 1.0MHz, R _L = 50Ω, C _L = 10pF | 2.25 | -2.25 | -60 | | | dB |
| | | 4.50 | -4.50 | -60 | | | | |
| THD | Total Harmonic Distortion (Figure 14) | f _{in} = 1kHz, R _L = 10kΩ, C _L = 50pF THD = THD _{measured} - THD _{source} V _{IS} = 4.0V _{PP} sine wave | 2.25 | -2.25 | 0.10 | | | % |
| | | V _{IS} = 8.0V _{PP} sine wave | 4.50 | -4.50 | 0.08 | | | |
| | | V _{IS} = 11.0V _{PP} sine wave | 6.00 | -6.00 | 0.05 | | | |

*Limits not tested. Determined by design and verified by qualification.

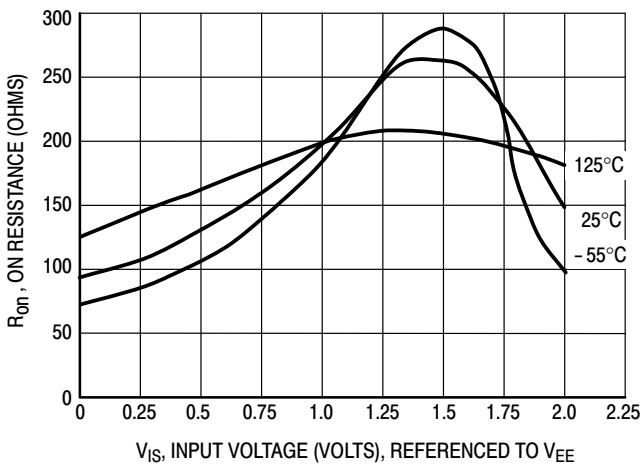

Figure 1a. Typical On Resistance, V_{CC} - V_{EE} = 2.0 V

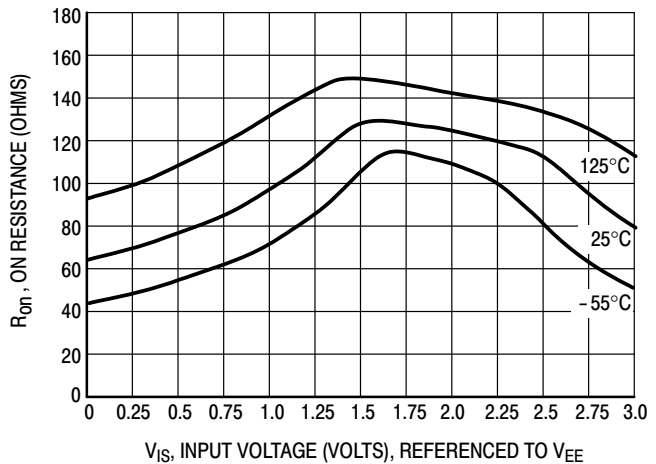

Figure 1b. Typical On Resistance, V_{CC} - V_{EE} = 3.0 V

MC74HC4051A, MC74HC4052A, MC74HC4053A

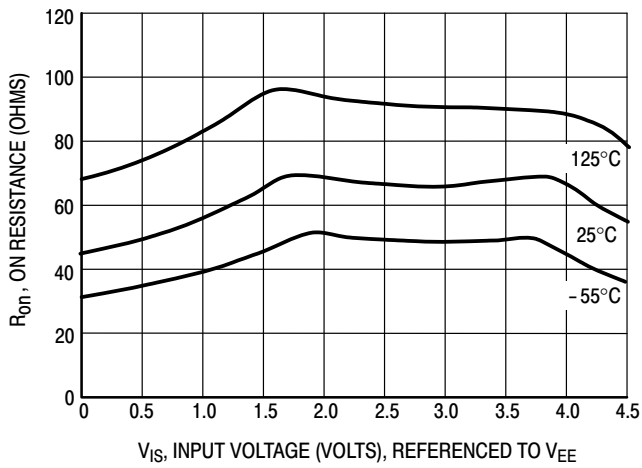

Figure 1c. Typical On Resistance, $V_{CC} - V_{EE} = 4.5 \text{ V}$

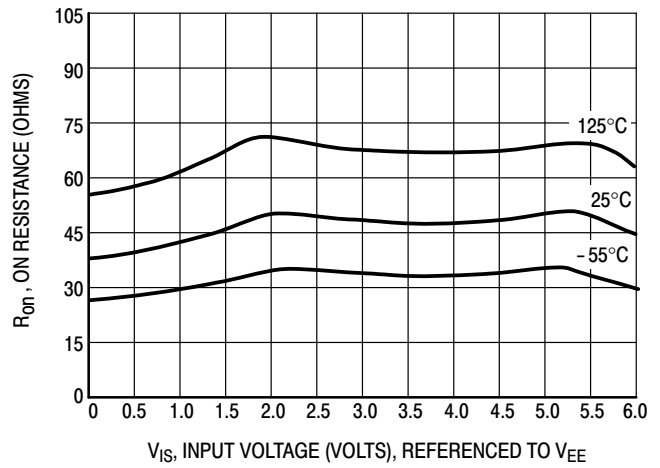

Figure 1d. Typical On Resistance, $V_{CC} - V_{EE} = 6.0 \text{ V}$

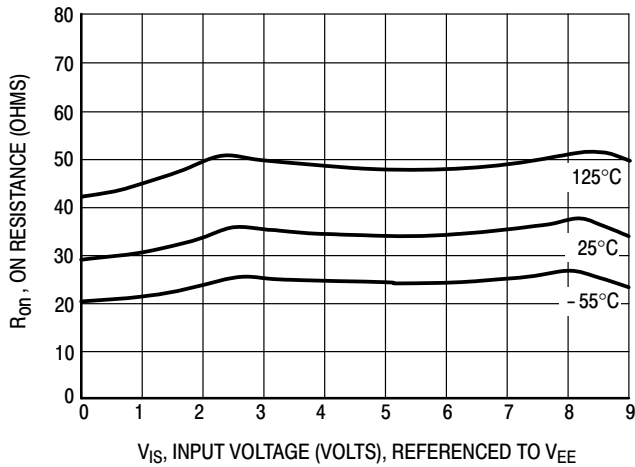

Figure 1e. Typical On Resistance, $V_{CC} - V_{EE} = 9.0 \text{ V}$

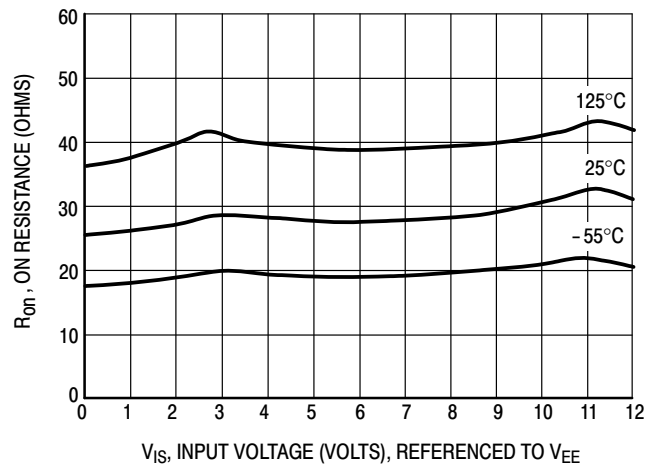

Figure 1f. Typical On Resistance, $V_{CC} - V_{EE} = 12.0 \text{ V}$

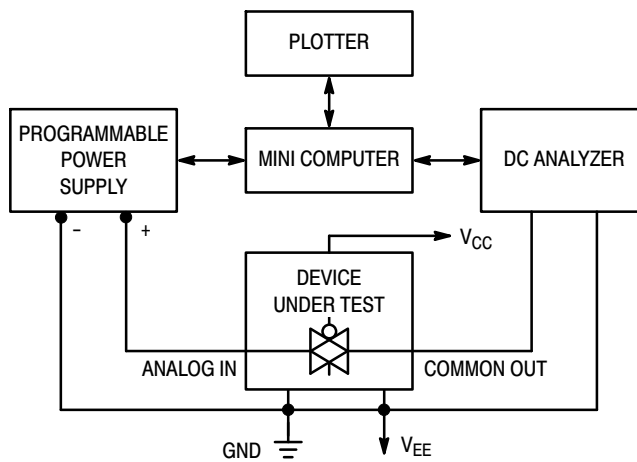

Figure 2. On Resistance Test Set-Up

MC74HC4051A, MC74HC4052A, MC74HC4053A

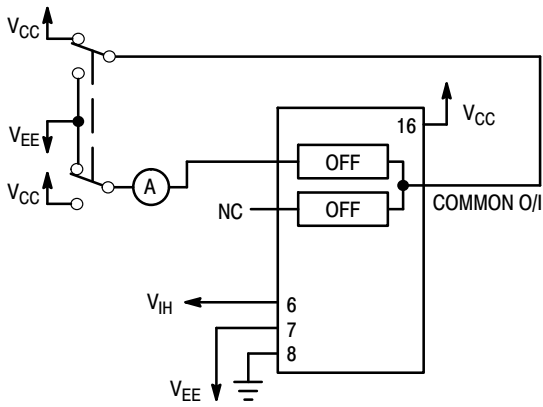

Figure 3. Maximum Off Channel Leakage Current, Any One Channel, Test Set-Up

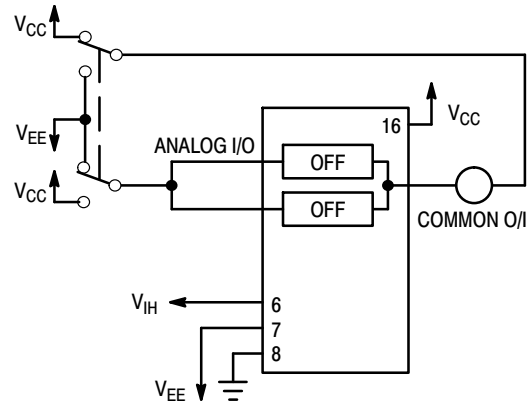

Figure 4. Maximum Off Channel Leakage Current, Common Channel, Test Set-Up

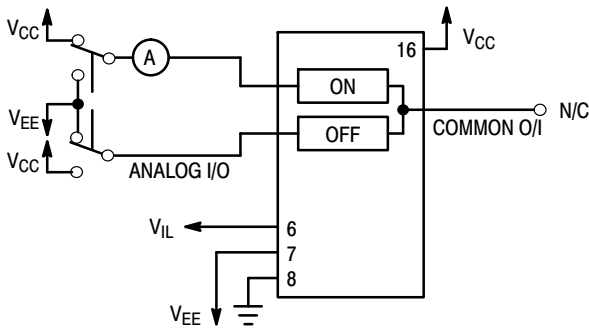

Figure 5. Maximum On Channel Leakage Current, Channel to Channel, Test Set-Up

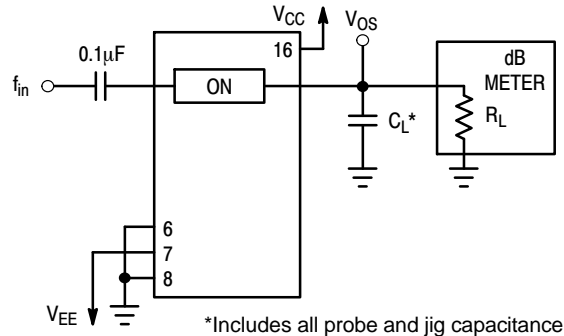

Figure 6. Maximum On Channel Bandwidth, Test Set-Up

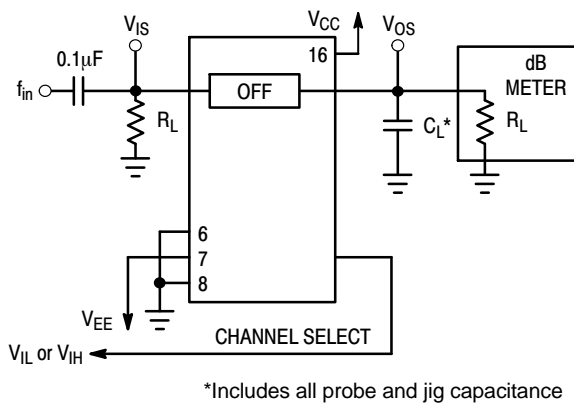

Figure 7. Off Channel Feedthrough Isolation, Test Set-Up

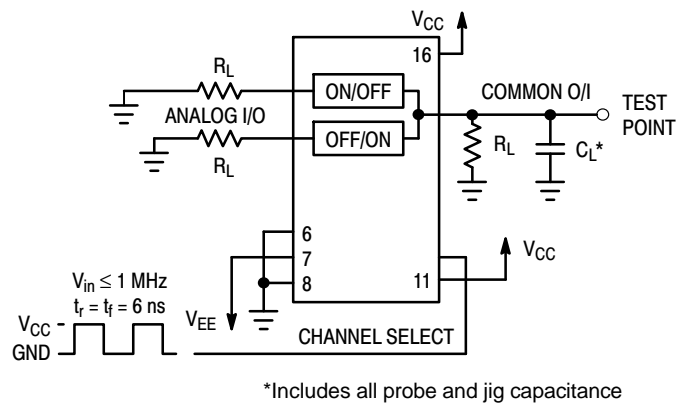

Figure 8. Feedthrough Noise, Channel Select to Common Out, Test Set-Up

MC74HC4051A, MC74HC4052A, MC74HC4053A

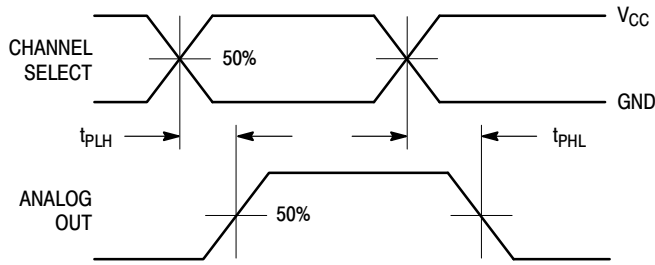
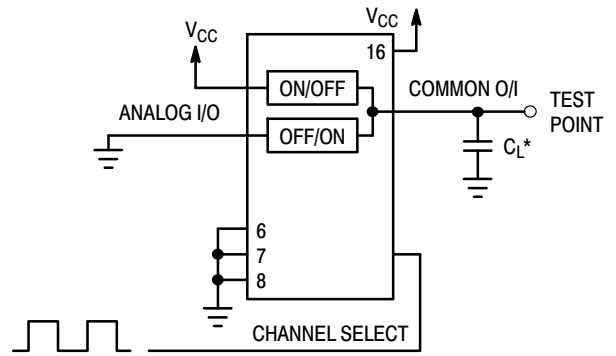

Figure 9a. Propagation Delays, Channel Select to Analog Out



*Includes all probe and jig capacitance

Figure 9b. Propagation Delay, Test Set-Up Channel Select to Analog Out

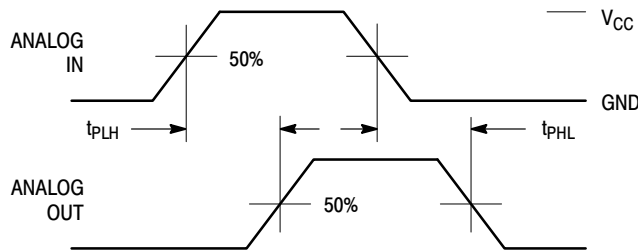
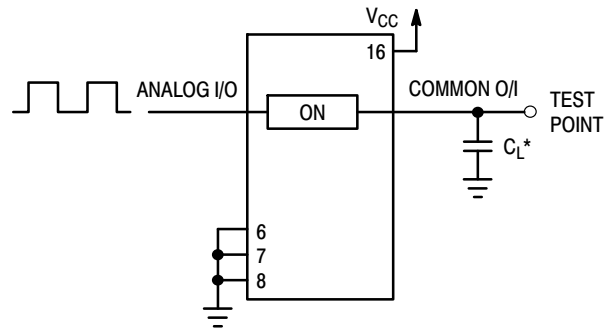

Figure 10a. Propagation Delays, Analog In to Analog Out



*Includes all probe and jig capacitance

Figure 10b. Propagation Delay, Test Set-Up Analog In to Analog Out

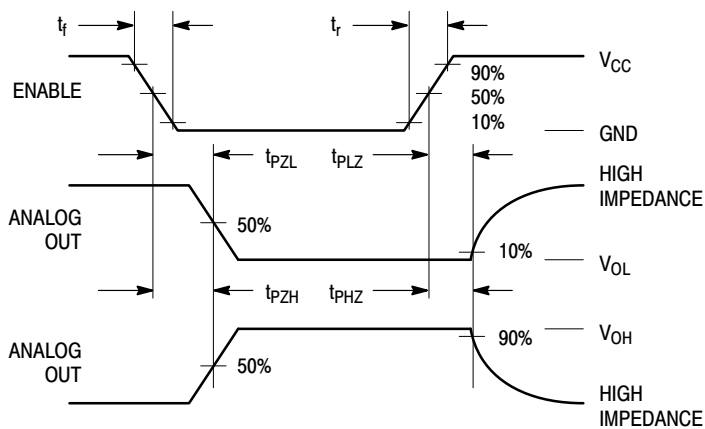

Figure 11a. Propagation Delays, Enable to Analog Out

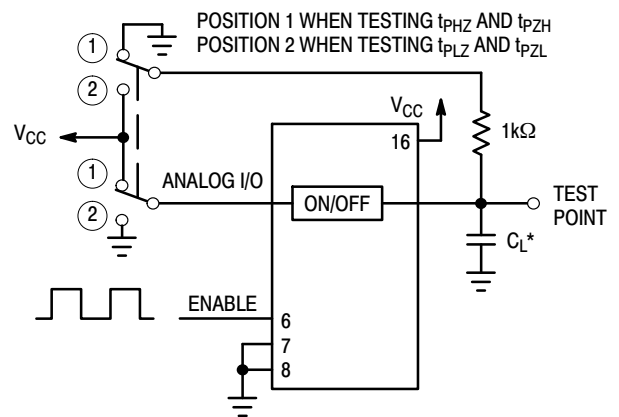
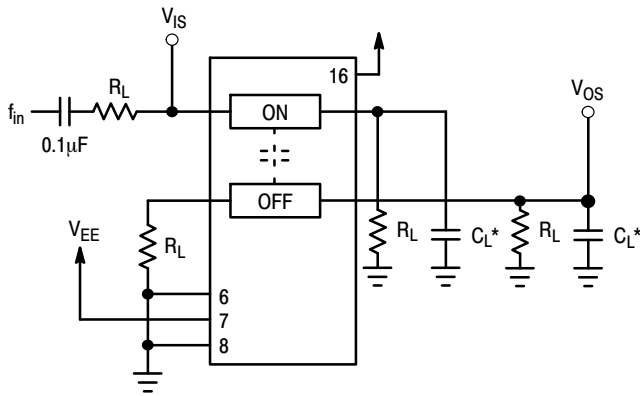

Figure 11b. Propagation Delay, Test Set-Up Enable to Analog Out

MC74HC4051A, MC74HC4052A, MC74HC4053A



*Includes all probe and jig capacitance

Figure 12. Crosstalk Between Any Two Switches, Test Set-Up

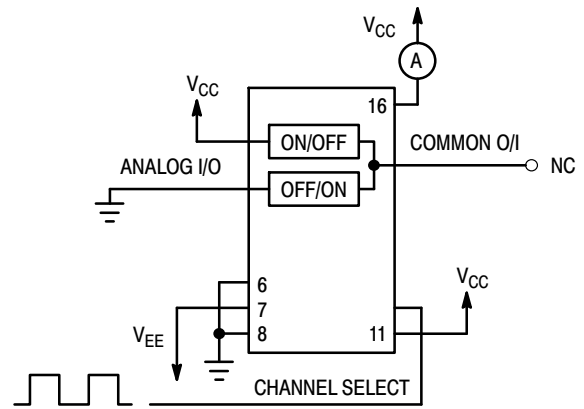
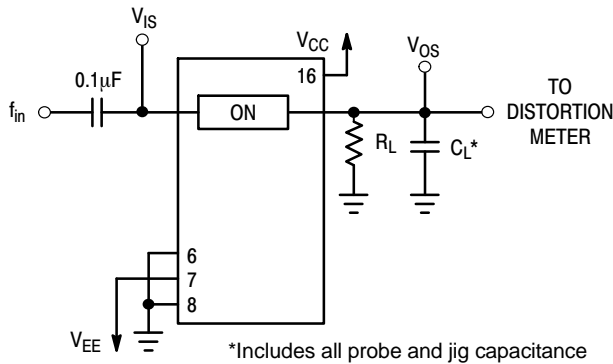

Figure 13. Power Dissipation Capacitance, Test Set-Up



*Includes all probe and jig capacitance

Figure 14a. Total Harmonic Distortion, Test Set-Up

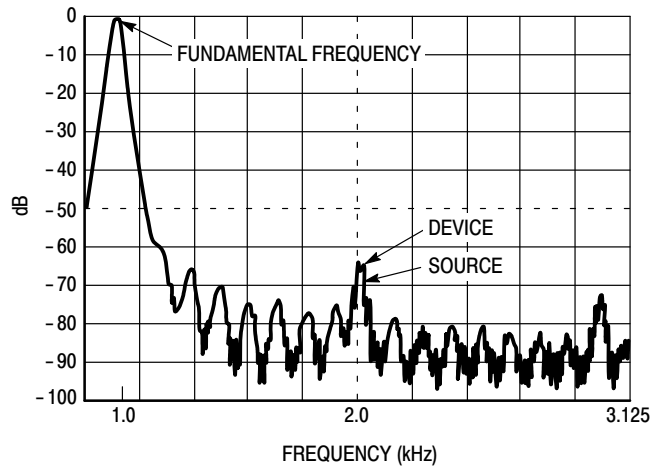

Figure 14b. Plot, Harmonic Distortion

APPLICATIONS INFORMATION

The Channel Select and Enable control pins should be at V_{CC} or GND logic levels. V_{CC} being recognized as a logic high and GND being recognized as a logic low. In this example:

$$\begin{aligned} V_{CC} &= +5V = \text{logic high} \\ \text{GND} &= 0V = \text{logic low} \end{aligned}$$

The maximum analog voltage swings are determined by the supply voltages V_{CC} and V_{EE} . The positive peak analog voltage should not exceed V_{CC} . Similarly, the negative peak analog voltage should not go below V_{EE} . In this example, the difference between V_{CC} and V_{EE} is ten volts. Therefore, using the configuration of Figure 15, a maximum analog signal of ten volts peak-to-peak can be controlled. Unused analog inputs/outputs may be left floating (i.e., not connected). However, tying unused analog inputs and

outputs to V_{CC} or GND through a low value resistor helps minimize crosstalk and feed-through noise that may be picked up by an unused switch.

Although used here, balanced supplies are not a requirement. The only constraints on the power supplies are that:

$$\begin{aligned} V_{CC} - \text{GND} &= 2 \text{ to } 6 \text{ volts} \\ V_{EE} - \text{GND} &= 0 \text{ to } -6 \text{ volts} \\ V_{CC} - V_{EE} &= 2 \text{ to } 12 \text{ volts} \\ &\text{and } V_{EE} \leq \text{GND} \end{aligned}$$

When voltage transients above V_{CC} and/or below V_{EE} are anticipated on the analog channels, external Germanium or Schottky diodes (D_x) are recommended as shown in Figure 16. These diodes should be able to absorb the maximum anticipated current surges during clipping.

MC74HC4051A, MC74HC4052A, MC74HC4053A

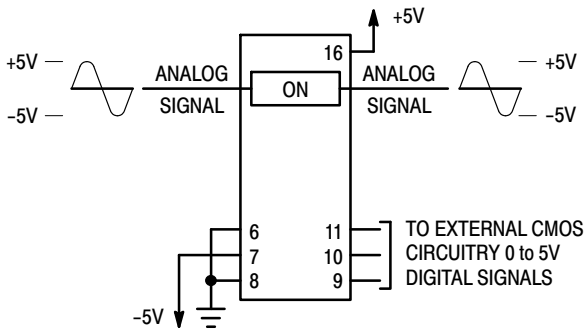

Figure 15. Application Example

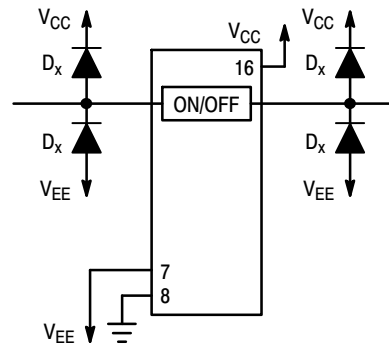
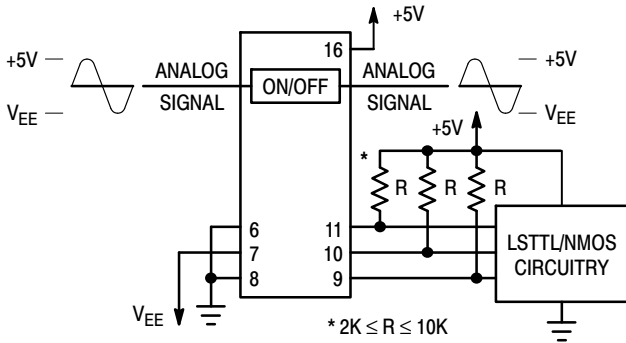
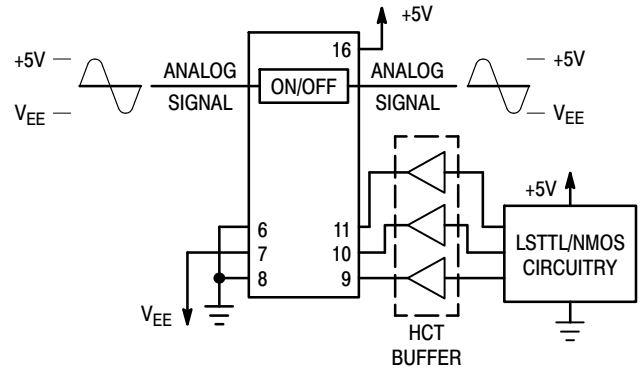

Figure 16. External Germanium or Schottky Clipping Diodes



a. Using Pull-Up Resistors



b. Using HCT Interface

Figure 17. Interfacing LSTTL/NMOS to CMOS Inputs

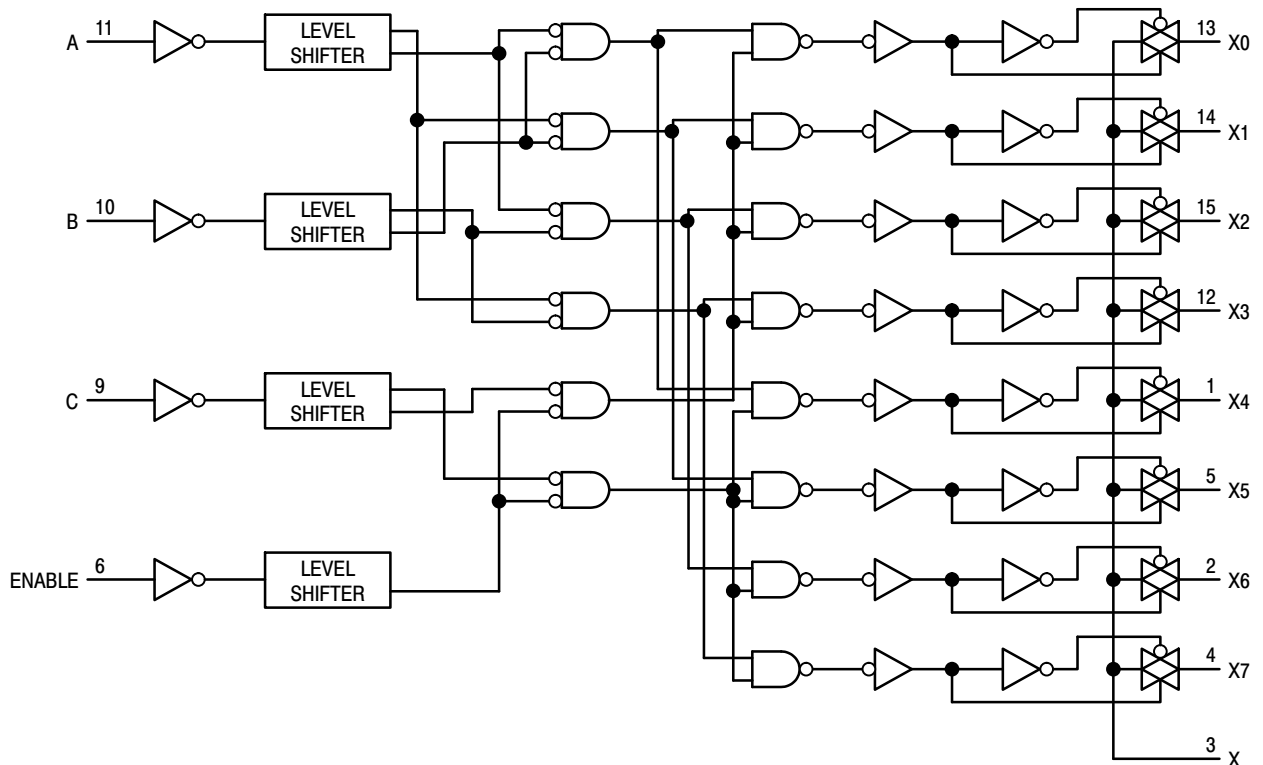

Figure 18. Function Diagram, HC4051A

MC74HC4051A, MC74HC4052A, MC74HC4053A

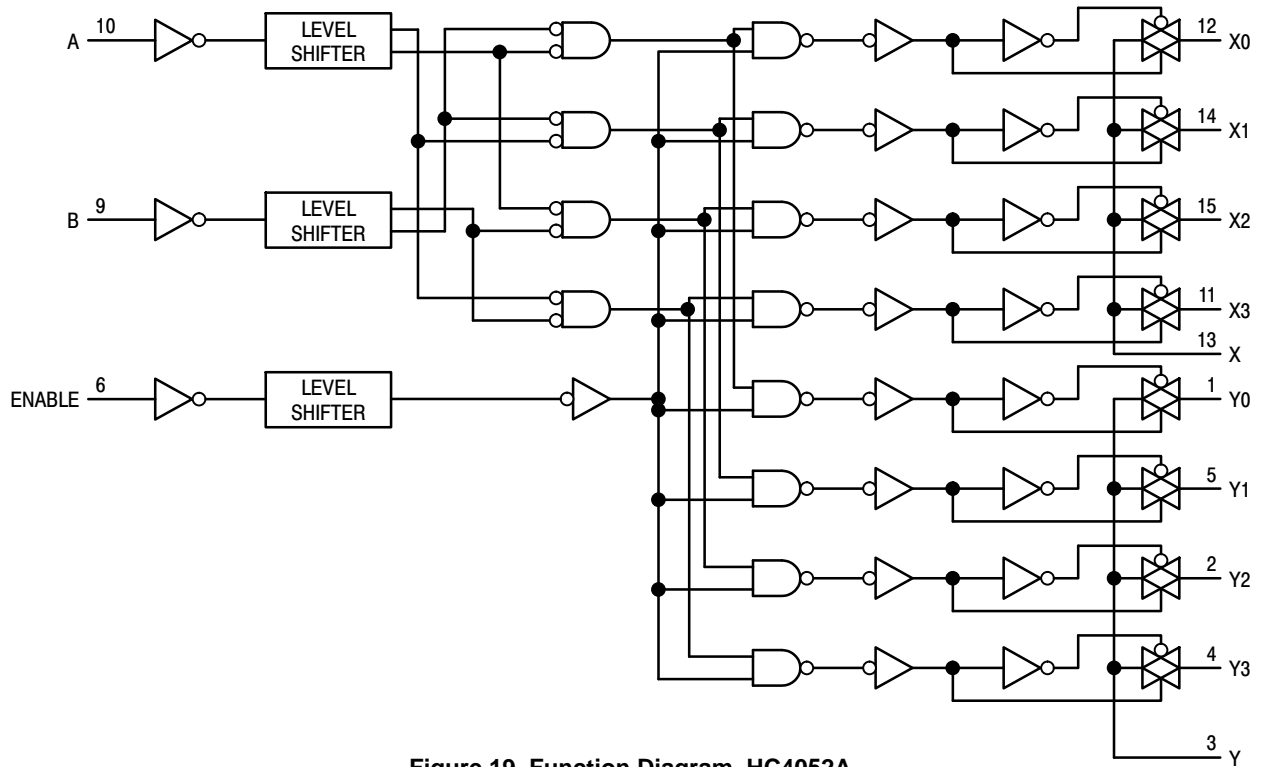

Figure 19. Function Diagram, HC4052A

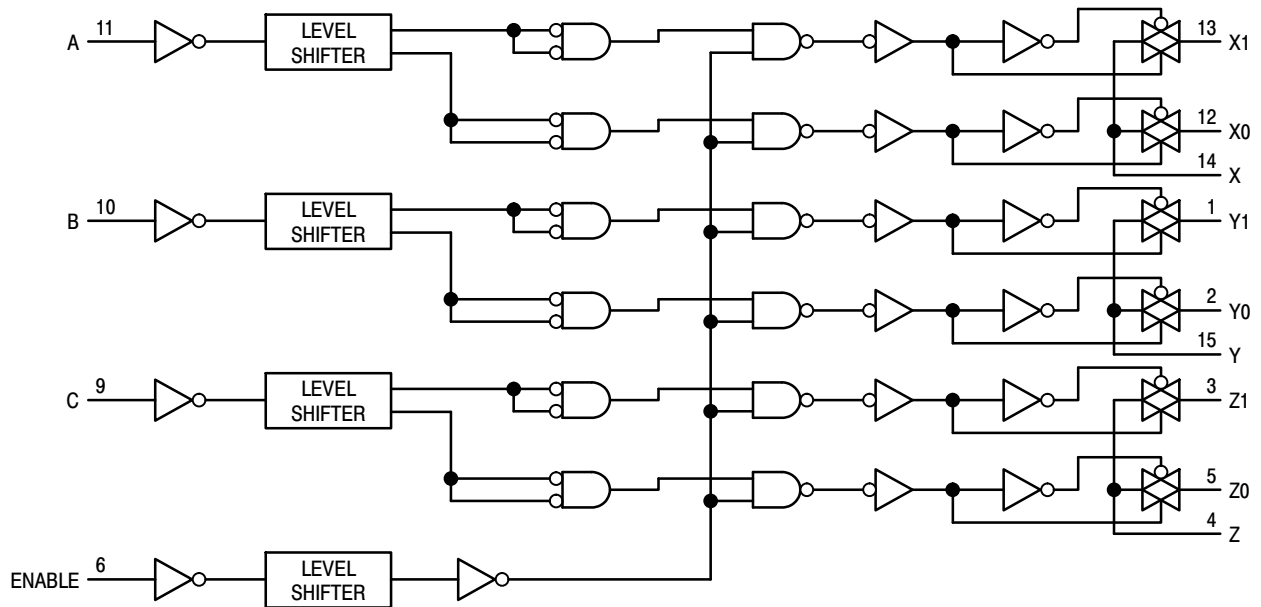

Figure 20. Function Diagram, HC4053A

MC74HC4051A, MC74HC4052A, MC74HC4053A

ORDERING INFORMATION

| Device | Package | Shipping† |
|--------------------------------------|---------------------------|--------------------------|
| MC74HC4051ADG | SOIC-16 (Pb-Free) | 48 Units / Rail |
| MC74HC4051ADR2G | | 2500 Units / Tape & Reel |
| NLV74HC4051ADR2G* | | 2500 Units / Tape & Reel |
| MC74HC4051ADWG | SOIC-16 WIDE (Pb-Free) | 48 Units / Rail |
| MC74HC4051ADWR2G | | 1000 Units / Tape & Reel |
| NLVHC4051ADWR2G* | | 1000 Units / Tape & Reel |
| MC74HC4051ADTG | TSSOP-16 (Pb-Free) | 96 Units / Rail |
| MC74HC4051ADTR2G | | 2500 Units / Tape & Reel |
| NLVHC4051ADTR2G* | | 2500 Units / Tape & Reel |
| NLVHC4051AMNTWG* (In Development) | QFN16 (Pb-Free) | 3000 Units / Tape & Reel |

| | | |
|--------------------------------------|---------------------------|--------------------------|
| MC74HC4052ADG | SOIC-16 (Pb-Free) | 48 Units / Rail |
| MC74HC4052ADR2G | | 2500 Units / Tape & Reel |
| NLV74HC4052ADR2G* | | 2500 Units / Tape & Reel |
| MC74HC4052ADWG | SOIC-16 WIDE (Pb-Free) | 48 Units / Rail |
| MC74HC4052ADWR2G | | 1000 Units / Tape & Reel |
| MC74HC4052ADTG | | 96 Units / Rail |
| MC74HC4052ADTR2G | TSSOP-16 (Pb-Free) | 2500 Units / Tape & Reel |
| NLV74HC4052ADTR2G* | | 2500 Units / Tape & Reel |
| NLVHC4052ADTR2G* | | 2500 Units / Tape & Reel |
| NLVHC4052AMNTWG* (In Development) | QFN16 (Pb-Free) | 3000 Units / Tape & Reel |

| | | |
|--------------------|---------------------------|--------------------------|
| MC74HC4053ADG | SOIC-16 (Pb-Free) | 48 Units / Rail |
| MC74HC4053ADR2G | | 2500 Units / Tape & Reel |
| NLV74HC4053ADR2G* | | 2500 Units / Tape & Reel |
| MC74HC4053ADWG | SOIC-16 WIDE (Pb-Free) | 48 Units / Rail |
| NLV74HC4053ADWRG* | | 1000 Units / Tape & Reel |
| MC74HC4053ADWR2G | | 1000 Units / Tape & Reel |
| NLV74HC4053ADWR2G* | | 1000 Units / Tape & Reel |
| MC74HC4053ADTG | TSSOP-16 (Pb-Free) | 96 Units / Rail |
| MC74HC4053ADTR2G | | 2500 Units / Tape & Reel |
| NLVHC4053ADTR2G* | | 2500 Units / Tape & Reel |

†For information on tape and reel specifications, including part orientation and tape sizes, please refer to our Tape and Reel Packaging Specifications Brochure, BRD8011/D.

*NLV Prefix for Automotive and Other Applications Requiring Unique Site and Control Change Requirements; AEC-Q100 Qualified and PPAP Capable.

MC74HC4051A, MC74HC4052A, MC74HC4053A

PACKAGE DIMENSIONS

TSSOP-16
CASE 948F
ISSUE B

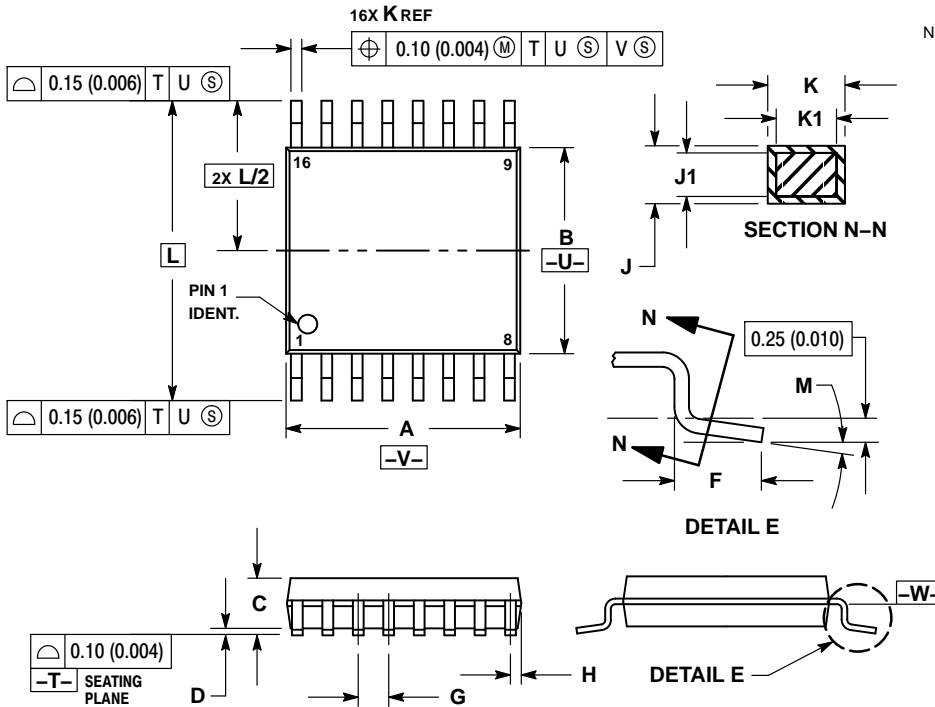

NOTES:

1. DIMENSIONING AND TOLERANCING PER ANSI Y14.5M, 1982.
2. CONTROLLING DIMENSION: MILLIMETER.
3. DIMENSION A DOES NOT INCLUDE MOLD FLASH, PROTRUSIONS OR GATE BURRS. MOLD FLASH OR GATE BURRS SHALL NOT EXCEED 0.15 (0.006) PER SIDE.
4. DIMENSION B DOES NOT INCLUDE INTERLEAD FLASH OR PROTRUSION. INTERLEAD FLASH OR PROTRUSION SHALL NOT EXCEED 0.25 (0.010) PER SIDE.
5. DIMENSION K DOES NOT INCLUDE DAMBAR PROTRUSION. ALLOWABLE DAMBAR PROTRUSION SHALL BE 0.08 (0.003) TOTAL IN EXCESS OF THE K DIMENSION AT MAXIMUM MATERIAL CONDITION.
6. TERMINAL NUMBERS ARE SHOWN FOR REFERENCE ONLY.
7. DIMENSION A AND B ARE TO BE DETERMINED AT DATUM PLANE -W-.

SOLDERING FOOTPRINT*

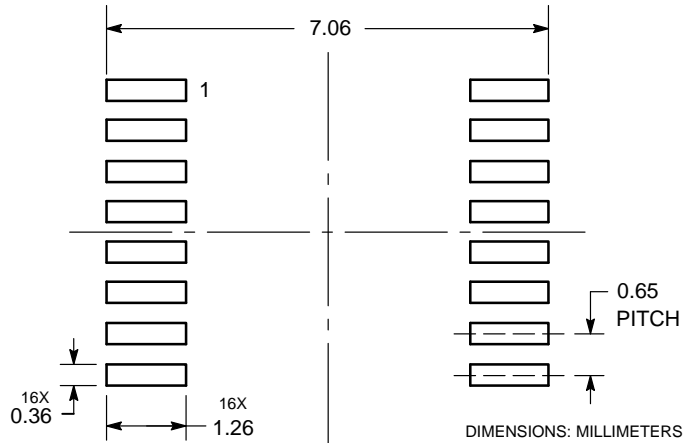

*For additional information on our Pb-Free strategy and soldering details, please download the ON Semiconductor Soldering and Mounting Techniques Reference Manual, SOLDERRM/D.

MC74HC4051A, MC74HC4052A, MC74HC4053A

PACKAGE DIMENSIONS

SOIC-16 WB
CASE 751G-03
ISSUE D

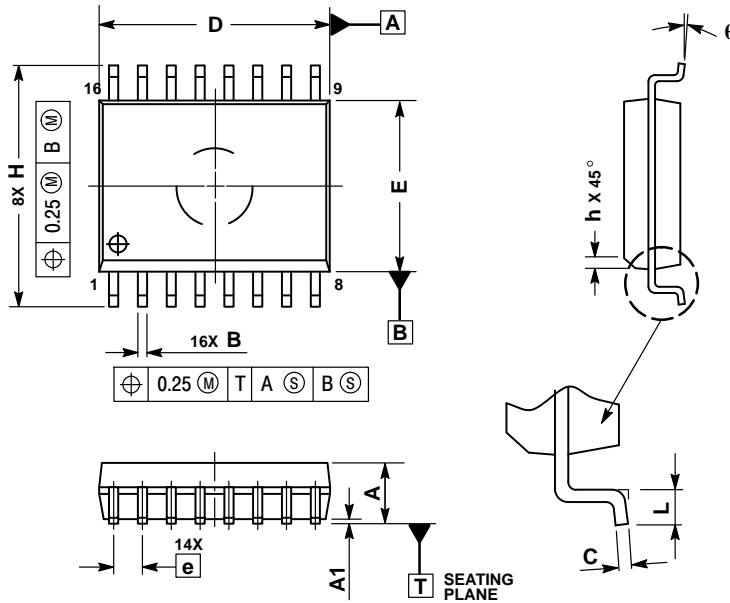

NOTES:

1. DIMENSIONS ARE IN MILLIMETERS.
2. INTERPRET DIMENSIONS AND TOLERANCES PER ASME Y14.5M, 1994.
3. DIMENSIONS D AND E DO NOT INCLUDE MOLD PROTRUSION.
4. MAXIMUM MOLD PROTRUSION 0.15 PER SIDE.
5. DIMENSION B DOES NOT INCLUDE DAMBAR PROTRUSION. ALLOWABLE DAMBAR PROTRUSION SHALL BE 0.13 TOTAL IN EXCESS OF THE B DIMENSION AT MAXIMUM MATERIAL CONDITION.

| DIM | MILLIMETERS | |
|-----|-------------|-------|
| | MIN | MAX |
| A | 2.35 | 2.65 |
| A1 | 0.10 | 0.25 |
| B | 0.35 | 0.49 |
| C | 0.23 | 0.32 |
| D | 10.15 | 10.45 |
| E | 7.40 | 7.60 |
| e | 1.27 BSC | |
| H | 10.05 | 10.55 |
| h | 0.25 | 0.75 |
| L | 0.50 | 0.90 |
| q | 0° 7° | |

SOLDERING FOOTPRINT*

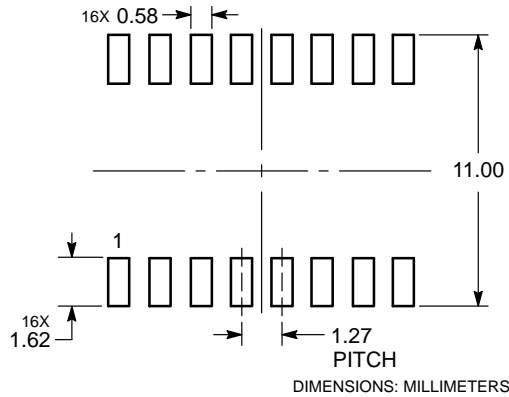

*For additional information on our Pb-Free strategy and soldering details, please download the ON Semiconductor Soldering and Mounting Techniques Reference Manual, SOLDERRM/D.

MC74HC4051A, MC74HC4052A, MC74HC4053A

PACKAGE DIMENSIONS

SOIC-16
CASE 751B-05
ISSUE K

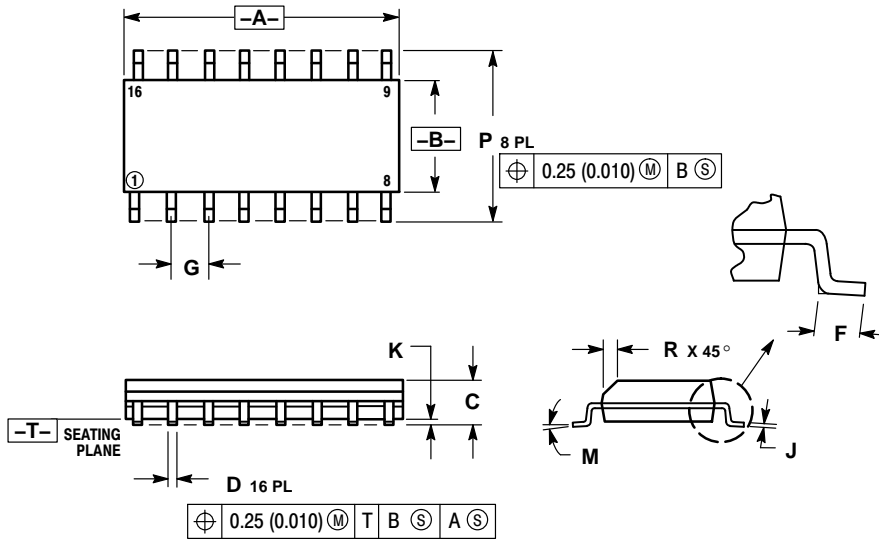

NOTES:

1. DIMENSIONING AND TOLERANCING PER ANSI Y14.5M, 1982.
2. CONTROLLING DIMENSION: MILLIMETER.
3. DIMENSIONS A AND B DO NOT INCLUDE MOLD PROTRUSION.
4. MAXIMUM MOLD PROTRUSION 0.15 (0.006) PER SIDE.
5. DIMENSION D DOES NOT INCLUDE DAMBAR PROTRUSION. ALLOWABLE DAMBAR PROTRUSION SHALL BE 0.127 (0.005) TOTAL IN EXCESS OF THE D DIMENSION AT MAXIMUM MATERIAL CONDITION.

| DIM | MILLIMETERS | | INCHES | |
|-----|-------------|-------|-----------|-------|
| | MIN | MAX | MIN | MAX |
| A | 9.80 | 10.00 | 0.386 | 0.393 |
| B | 3.80 | 4.00 | 0.150 | 0.157 |
| C | 1.35 | 1.75 | 0.054 | 0.068 |
| D | 0.35 | 0.49 | 0.014 | 0.019 |
| F | 0.40 | 1.25 | 0.016 | 0.049 |
| G | 1.27 BSC | | 0.050 BSC | |
| J | 0.19 | 0.25 | 0.008 | 0.009 |
| K | 0.10 | 0.25 | 0.004 | 0.009 |
| M | 0° | 7° | 0° | 7° |
| P | 5.80 | 6.20 | 0.229 | 0.244 |
| R | 0.25 | 0.50 | 0.010 | 0.019 |

SOLDERING FOOTPRINT*

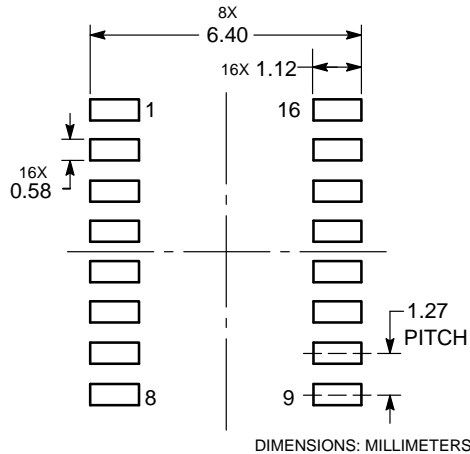

*For additional information on our Pb-Free strategy and soldering details, please download the ON Semiconductor Soldering and Mounting Techniques Reference Manual, SOLDERRM/D.

MC74HC4051A, MC74HC4052A, MC74HC4053A

PACKAGE DIMENSIONS

QFN16, 2.5x3.5, 0.5P
CASE 485AW
ISSUE O

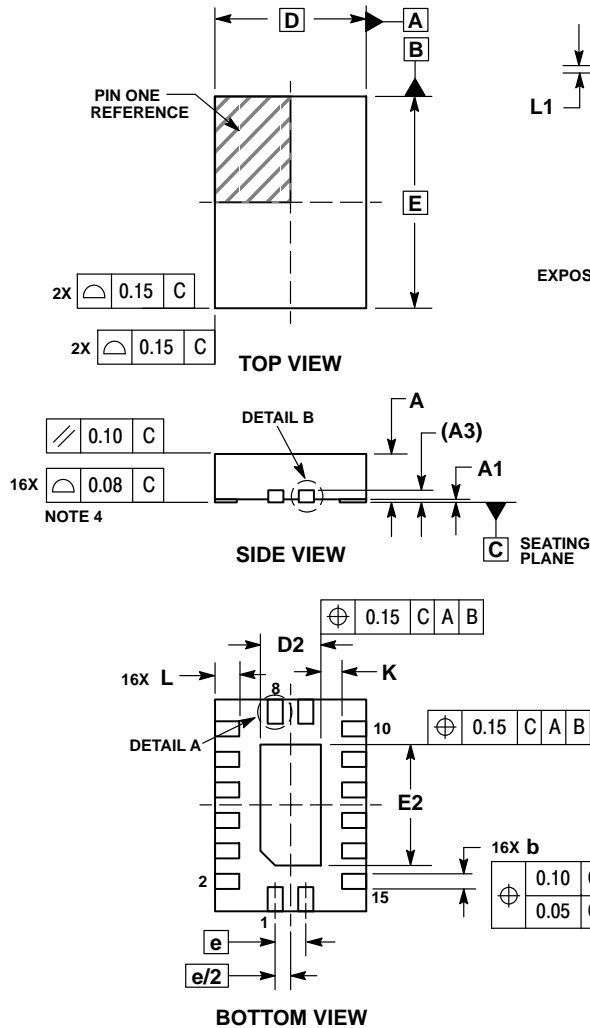

NOTES:

1. DIMENSIONING AND TOLERANCING PER ASME Y14.5M, 1994.
2. CONTROLLING DIMENSION: MILLIMETERS.
3. DIMENSIONS b APPLIES TO PLATED TERMINAL AND IS MEASURED BETWEEN 0.15 AND 0.30 MM FROM TERMINAL.
4. COPLANARITY APPLIES TO THE EXPOSED PAD AS WELL AS THE TERMINALS.

| DIM | MILLIMETERS | |
|-----|-------------|------|
| | MIN | MAX |
| A | 0.80 | 1.00 |
| A1 | 0.00 | 0.05 |
| A3 | 0.20 | REF |
| b | 0.20 | 0.30 |
| D | 2.50 | BSC |
| D2 | 0.85 | 1.15 |
| E | 3.50 | BSC |
| E2 | 1.85 | 2.15 |
| e | 0.50 | BSC |
| K | 0.20 | --- |
| L | 0.35 | 0.45 |
| L1 | --- | 0.15 |

SOLDERING FOOTPRINT*

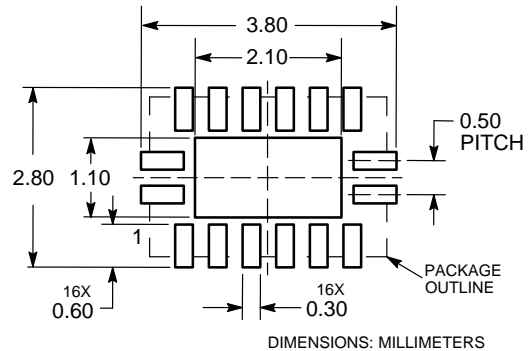

*For additional information on our Pb-Free strategy and soldering details, please download the ON Semiconductor Soldering and Mounting Techniques Reference Manual, SOLDERRM/D.

ON Semiconductor and are trademarks of Semiconductor Components Industries, LLC dba ON Semiconductor or its subsidiaries in the United States and/or other countries. ON Semiconductor owns the rights to a number of patents, trademarks, copyrights, trade secrets, and other intellectual property. A listing of ON Semiconductor's product/patent coverage may be accessed at www.onsemi.com/site/pdf/Patent-Marking.pdf. ON Semiconductor reserves the right to make changes without further notice to any products herein. ON Semiconductor makes no warranty, representation or guarantee regarding the suitability of its products for any particular purpose, nor does ON Semiconductor assume any liability arising out of the application or use of any product or circuit, and specifically disclaims any and all liability, including without limitation special, consequential or incidental damages. Buyer is responsible for its products and applications using ON Semiconductor products, including compliance with all laws, regulations and safety requirements or standards, regardless of any support or applications information provided by ON Semiconductor. "Typical" parameters which may be provided in ON Semiconductor data sheets and/or specifications can and do vary in different applications and actual performance may vary over time. All operating parameters, including "Typicals" must be validated for each customer application by customer's technical experts. ON Semiconductor does not convey any license under its patent rights nor the rights of others. ON Semiconductor products are not designed, intended, or authorized for use as a critical component in life support systems or any FDA Class 3 medical devices or medical devices with a same or similar classification in a foreign jurisdiction or any devices intended for implantation in the human body. Should Buyer purchase or use ON Semiconductor products for any such unintended or unauthorized application, Buyer shall indemnify and hold ON Semiconductor and its officers, employees, subsidiaries, affiliates, and distributors harmless against all claims, costs, damages, and expenses, and reasonable attorney fees arising out of, directly or indirectly, any claim of personal injury or death associated with such unintended or unauthorized use, even if such claim alleges that ON Semiconductor was negligent regarding the design or manufacture of the part. ON Semiconductor is an Equal Opportunity/Affirmative Action Employer. This literature is subject to all applicable copyright laws and is not for resale in any manner.

PUBLICATION ORDERING INFORMATION

LITERATURE FULFILLMENT:
Literature Distribution Center for ON Semiconductor
19521 E. 32nd Pkwy, Aurora, Colorado 80011 USA
Phone: 303-675-2175 or 800-344-3860 Toll Free USA/Canada
Fax: 303-675-2176 or 800-344-3867 Toll Free USA/Canada
Email: orderlit@onsemi.com

N. American Technical Support: 800-282-9855 Toll Free
USA/Canada
Europe, Middle East and Africa Technical Support:
Phone: 421 33 790 2910
Japan Customer Focus Center
Phone: 81-3-5817-1050

ON Semiconductor Website: www.onsemi.com
Order Literature: <http://www.onsemi.com/orderlit>
For additional information, please contact your local Sales Representative