

Switching Power Supply Type SPD 960W 3 phases DIN rail mounting



- Universal AC 3 phases input full range
- Can also be used as single phase 480VAC
- Installation on DIN rail 7.5 or 15mm
- PFC as standard
- High efficiency up to 93%
- Power ready output
- Parallel connection feature (except "L" version)
- Compact dimensions
- UL, cUL listed and TUV/CE

Product Description

The Switching power supplies SPD XX9603 series are suitable for those applications where high DC power is required. Besides the PFC as standard, it also features the parallel connection with active current sharing on the high end versions.

Ordering Key

SP D 24 960 3 L

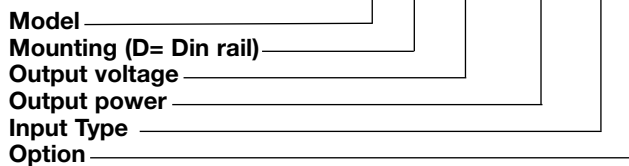

- Input type:** 3 = three phase
(or single phase 400/500VAC³)
- Option:** Nil = standard version
L = without active current sharing feature

Approvals



Output performances

MODEL NO.	INPUT VOLTAGE	OUTPUT WATTAGE	OUTPUT VOLTAGE	OUTPUT CURRENT	EFF. (min.)	EFF. (typ.)
Single Output Models						
SPD24	3ø 480 VAC	960 WATTS	+ 24 VDC	40 A	90%	92%
SPD24...L	3ø 480 VAC	960 WATTS	+ 24 VDC	40 A	90%	92%
SPD48	3ø 480 VAC	960 WATTS	+ 48 VDC	20 A	91%	93%

Output data

Line regulation	± 0.5%	Hold up time Vi nom ,Io nom	15ms
Load regulation		Voltage fall time (Io nom)	150ms max
Single mode	± 1%	Rated continuous loading	
Parallel mode	± 5%	24V Model	40A @ 24VDC/33.8A @ 28.5VDC
Minimum load	0	48V Model	20A @ 48VDC/17A @ 56VDC
Turn on time (full resistive load)		Reverse voltage	
Vi nom, Io nom	1000ms	24V Model	35VDC
Vi nom, Io nom with 7000µF CAP	1500ms	48V Model	63VDC
Transient recovery time	2ms	Capacitor load	7000µF
Ripple and noise	80mVpp	Voltage rise time	
Output voltage accuracy	+ 1%	Vi nom Io nom	150ms
Temperature coefficient	± 0.03%/°C	Vi nom, Io nom with 7000µF CAP	500ms

Input data

Rated input voltage	400 - 500VAC	Power dissipation	
Voltage range		Vi: 400 VAC, lo nom 24V Model	98W
AC	340 - 575VAC MAX *	48V Model	55W
DC	480 - 820VDC MAX *	Frequency range	47- 63Hz
Rated input current (Vi: 340VAC, lo nom) Typ.	2.4A	Leakage current	
Inrush current		Input-Output	0.25mA
Vi nom, lo nom 24V/48V models	30 - 35A	Input-FG	3.5mA
Cold start 24L model	50 - 60A		
		*not suitable for 600 V applications	

Controls and Protections

Overload	120-140%	Contact rating at 60vdc	0.3A
Input fuse	T5A/500VAC internal/phase	Over voltage protection	VDC
Output short circuit	Hiccup mode		Min. Max.
Power ready output (only 24V model) On threshold	≥17.6 -19.4VDC	24V Model	30 33
Electrical isolation	500VDC	48V Model	60 68
		Internal surge voltage protection	Varistor
		(IEC 61000-4-5)	

General data (@ nominal line, full load, 25°C)

Ambient temperature	-40°C to 71°C	MTBF (Bellcore issue 6 @ 40°C, GB)	
Derating (>61°C to +71°C)	3.5%/°C	24V Model	352000 Hours
Ambient humidity	20 ~ 90%RH	24L Model	381000 Hours
Storage	-40°C to +85°C	48V Model	390000
Protection degree	IP20	Case material	Metal
Cooling	Free air convection	Dimensions LxWxD mm(inch)	1262(4.97)x275.8(10.86)x118.8(4.68)
Pollution degree	2	Weight	3400g

Norms and Standards

Vibration resistance	meet IEC 60068-2-6 (Mounting by rail: 10-500Hz, 2G, along X, Y, Z each Axis, 60 min for each Axis)	CCC	GB4943, GB9254, GB17625.1
Shock resistance	meet IEC 60068-2-27 (15G, 11ms, 3 Axis, 6 faces, 3 times for each face)	CE	EN 61000-6-3, EN 55022 Class B, EN 61000-3-2, EN 61000-3-3, EN 61000-6-2, EN 55024, EN 61000-4-2 Level 4, EN 61000-4-3 Level 3, EN 61000-4-4 Level 4, EN 61000-4-5 L-N Level 3, L/N-FG Level 4, EN 61000-4-6 Level 3, EN 61000-4-8 Level 4, EN 61000-4-11, ENV 50204 Level 2, EN 61204-3
UL / cUL	UL508 listed, UL60950-1, Recognized, ISA 12.12.01 (Class 1, Division 2, Groups A, B, C and D)		
TUV	EN 60950-1, CB scheme EN 61558-1, EN 61558-2-17 (meet EN 60204)		

Block diagrams

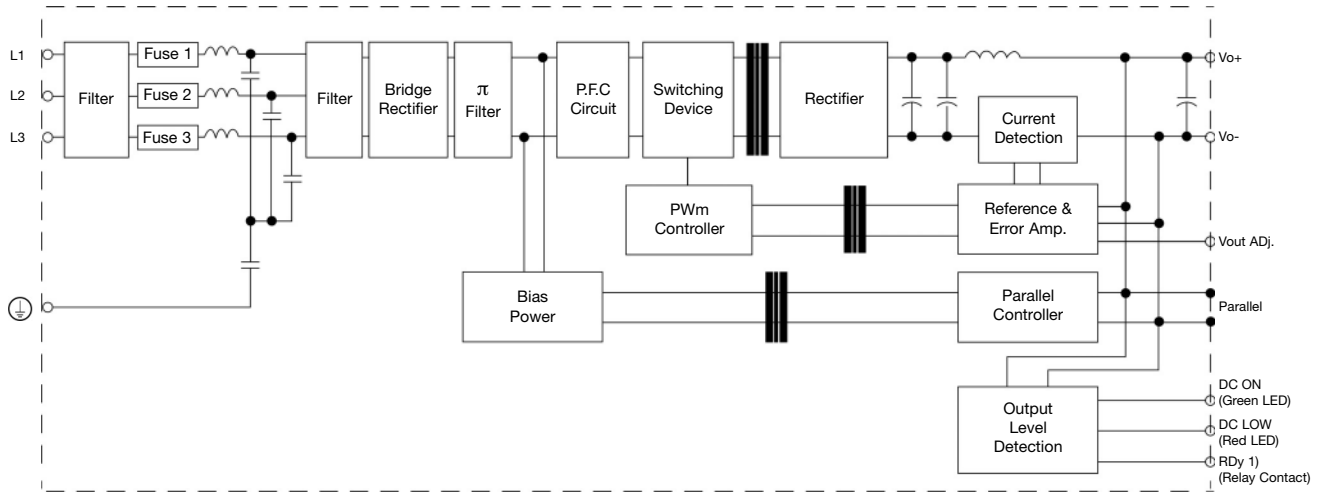

Pin Assignment and Front Controls

Pin No.	Designation	Description
1, 2	V-	Negative output terminal
3, 4	V+	Positive output terminal
5	G	Parallel GND PIN for current share
6	P	Parallel PIN for current share
7	RDY	A normal open relay contact for DC ON level control
8		(Never connect except 24V model)
9	L3	Input terminals
10	L2	Input terminals
11	L1	Input terminal
12		Ground this terminal to minimize high-frequency emission
	DC ON	Operation indicator LED
	DC LO	DC LOW voltage indicator LED
	Vout Adj	Trimmer-potentiometer for Vout adjustment

Parallel Connection

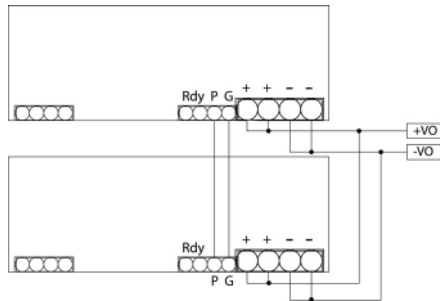

Derating Diagram

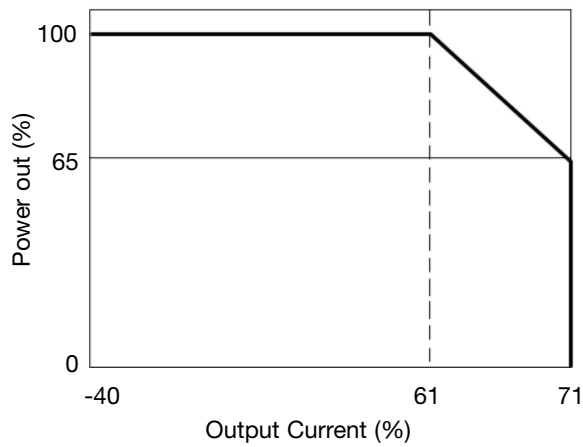

Typ. Efficiency Curve

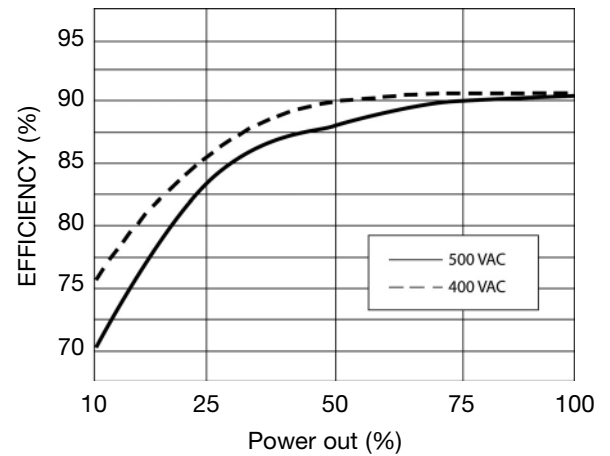

Typ. Current Limited Curve

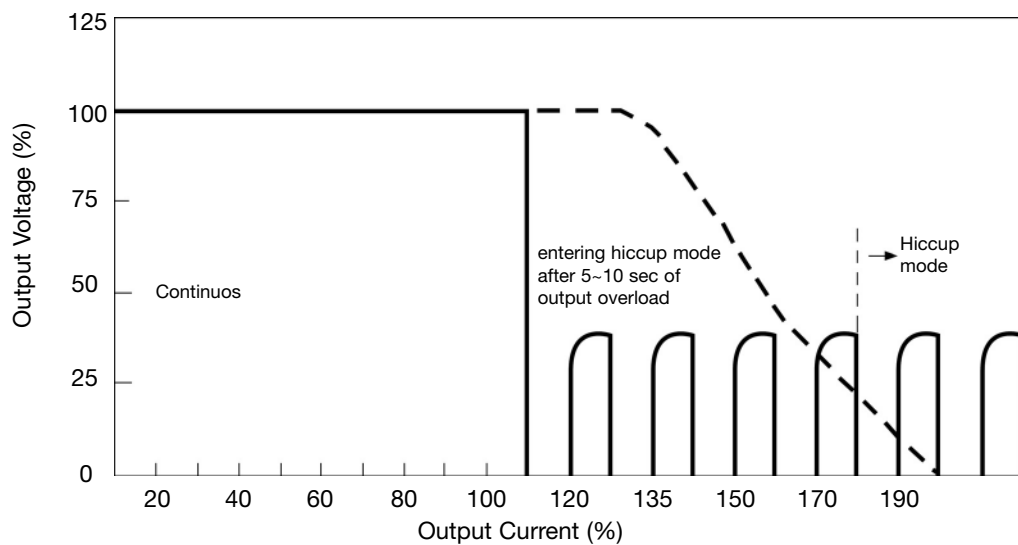

Mechanical Drawings mm/inches

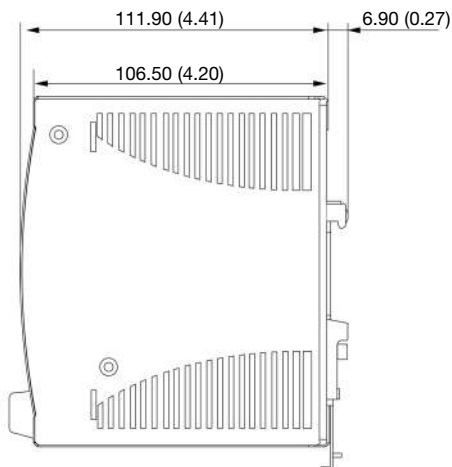
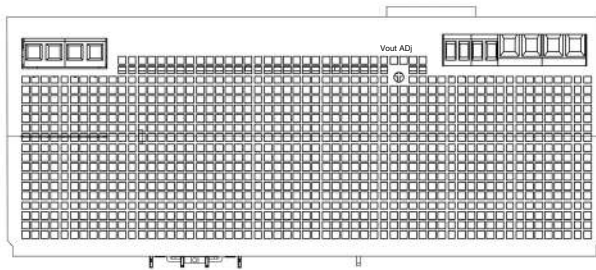
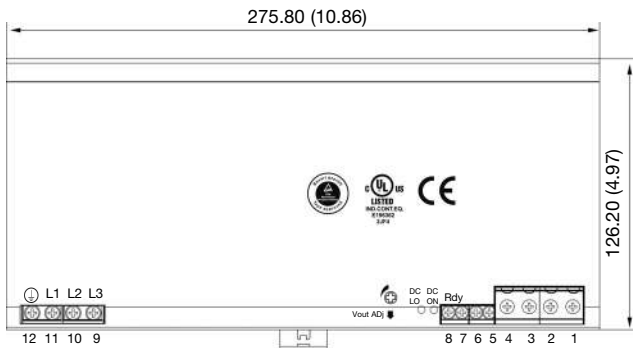

Installation

Ventilation and cooling

Normal convection
All sides 25mm free space
for cooling is recommended

Conductors sections

From Pin1 to Pin4

10-24AWG (0.2-4mm²) flexible
or solid cable 8mm stripping
recommend

From Pin5 to Pin8

6-20AWG (0.5-10mm²) flexible
or solid cable 8mm stripping
recommend

From Pin9 to Pin12

10-24AWG (0.2-4mm²) flexible
or solid cable 8mm stripping
recommend

Max. torque for screws terminals

From Pin1 to Pin4

1.008Nm (9.0lb-in)

From Pin5 to Pin8

1.763Nm (15.6lb-in)

From Pin9 to Pin12

0.616Nm (5.5lb-in)