

QDD-400-CUXM-C

Cisco® Compatible and TAA Compliant - 400GBase-CU QSFP-DD to QSFP-DD PAM-4 Direct Attach Cable (Passive Twinax, Up to 2.5m)

Features

- Compliant with QSFP-DD MSA Specification Rev 3.4
- SFF-8679 electrical interface compliant
- SFF-8636 management interface support
- Compliant with IEEE802.3Bj, By, IEEE802.3CD Standard
- Support 25G and 50G (PAM4) electrical data rates/channel
- I2C for EEPROM communication
- Pull to Release latch design
- Excellent EMI/EMC performance 360-degree cable shield termination
- Advantage dual side pre-solder automated assembly technologies
- Low loss, stronger mechanical features, more flexible
- QSFP-DD modules will be backwards compatible, allowing them to support existing QSFP modules and provide flexibility for end users and system designers
- ROHS-6 Compliant



Applications

- Data center & Networking Equipment
- Servers/Storage Devices
- High Performance Computing (HPC)
- Switches/Routers

Product Description

This is a Cisco® compatible TAA compliant 400GBase-CU QSFP-DD to QSFP-DD PAM-4 direct attach cable that operates over passive copper with a maximum reach up to 2.5m (8.2ft). It has been programmed, uniquely serialized, and data-traffic and application tested to ensure it is 100% compliant and functional. This direct attach cable is TAA (Trade Agreements Act) compliant, and is built to comply with MSA (Multi-Source Agreement) standards. We stand behind the quality of our products and proudly offer a limited lifetime warranty.

ProLabs' direct attach cables are RoHS compliant and lead-free.

TAA refers to the Trade Agreements Act (19 U.S.C. & 2501-2581), which is intended to foster fair and open international trade. TAA requires that the U.S. Government may acquire only "U.S. – made or designated country end products."



Order Information

Part Number	Description
QDD-400-CU1M-C	Cisco® QDD-400-CU1M Compatible and TAA Compliant - 400GBase-CU QSFP-DD to QSFP-DD PAM-4 Direct Attach Cable (Passive Twinax, 1m)
QDD-400-CU2M-C	Cisco® QDD-400-CU2M Compatible and TAA Compliant - 400GBase-CU QSFP-DD to QSFP-DD PAM-4 Direct Attach Cable (Passive Twinax, 2m)
QDD-400-CU2-5M-C	Cisco® QDD-400-CU2-5M Compatible and TAA Compliant - 400GBase-CU QSFP-DD to QSFP-DD PAM-4 Direct Attach Cable (Passive Twinax, 2.5m)

Regulatory Compliance

Certification	Standard
Laser Eye Safety	IEC: 60825-1, 3 rd Edition FDA: CFR-21 Sections 1040.10 and 1040.11
Product Safety	TUV: EN62368-1 UL/CSA 60950-1
EMC/EMI	FCC: Part 15 sb.B EN: 55032/55024

Schematic

WIRING TABLE---QSFP-DD TO QSFP-DD

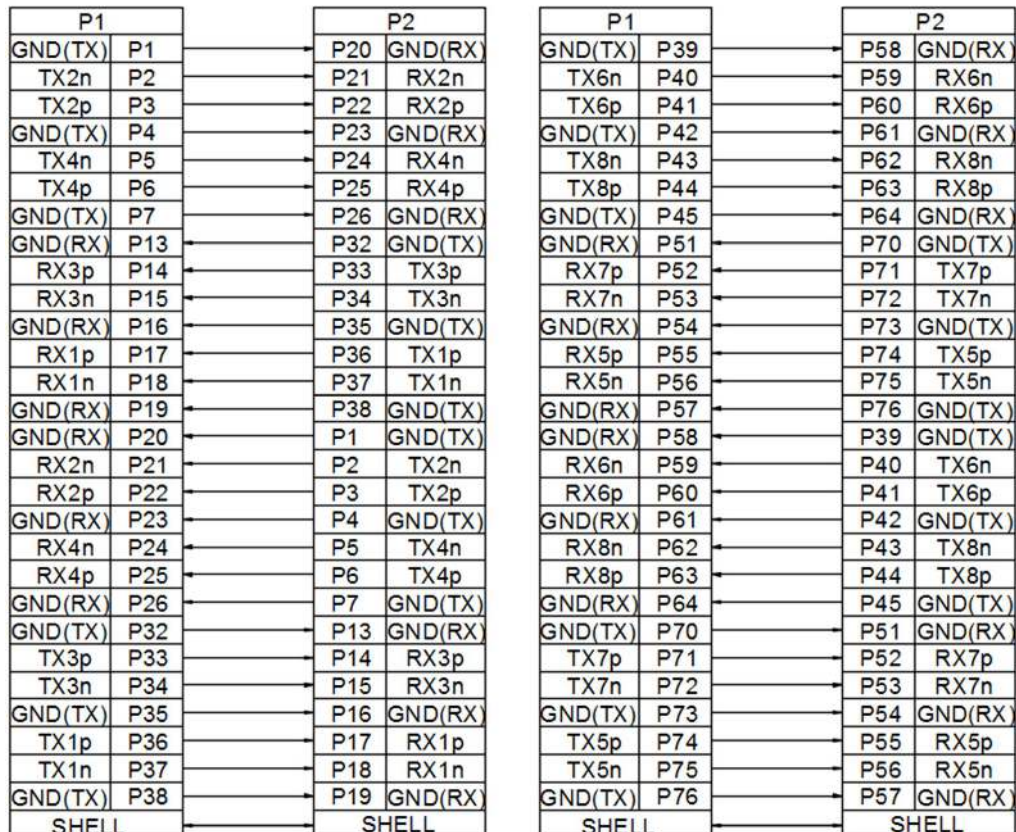

QSFP-DD 30AWG

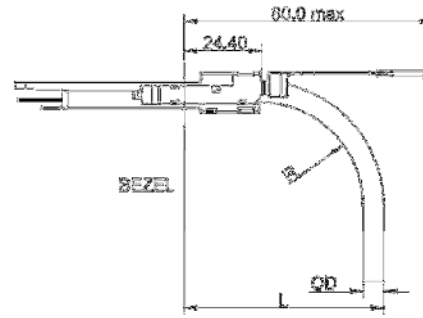
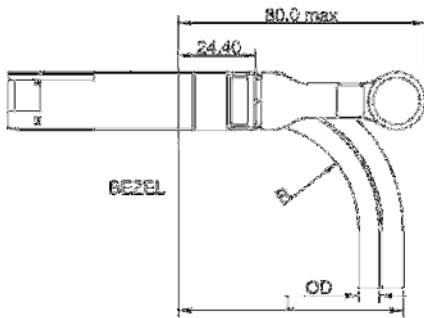

QSFP-DD Horizontal Direction			
CABLE GAUGE	DIAMETER "OD"	MIN. BEND RADIUS "R"	MIN. BEND SPACE "L"
30AWG	6.7MM	23.5MM	72MM

QSFP-DD Vertical Direction			
CABLE GAUGE	DIAMETER "OD"	MIN. BEND RADIUS "R"	MIN. BEND SPACE "L"
30AWG	6.7MM	30.5MM	65MM

QSFP-DD 28AWG

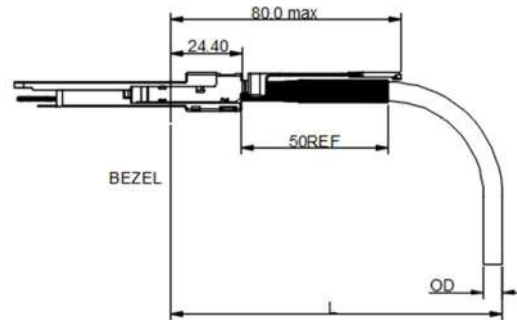
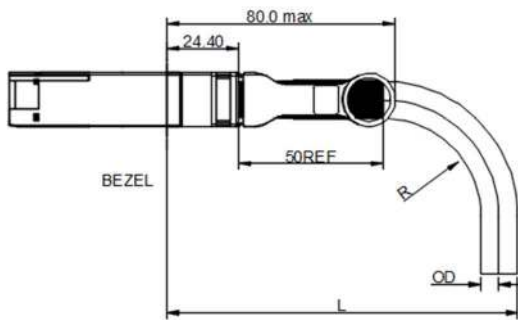

QSFP-DD Horizontal Direction			
CABLE GAUGE	DIAMETER "OD"	MIN. BEND RADIUS "R"	MIN. BEND SPACE "L"
28AWG	7.9MM	39.5MM	130MM

QSFP-DD Vertical Direction			
CABLE GAUGE	DIAMETER "OD"	MIN. BEND RADIUS "R"	MIN. BEND SPACE "L"
28AWG	7.9MM	39.5MM	122MM

QSFP-DD 26AWG

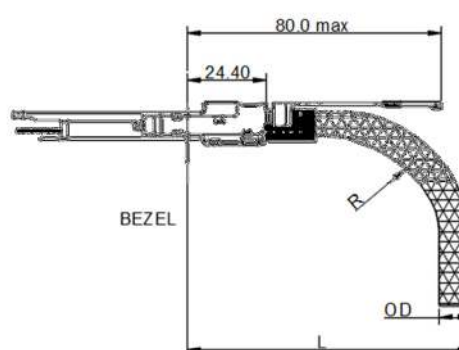
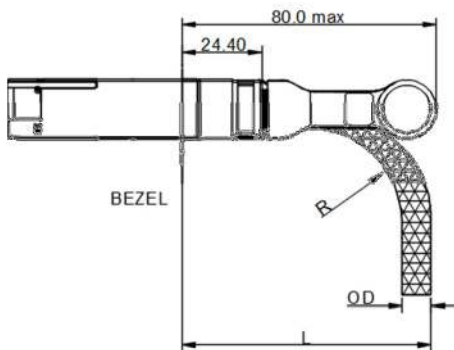

QSFP-DD Horizontal Direction			
CABLE GAUGE	DIAMETER "OD"	MIN. BEND RADIUS "R"	MIN. BEND SPACE "L"
26AWG	11.4MM	55MM	105MM

QSFP-DD Vertical Direction			
CABLE GAUGE	DIAMETER "OD"	MIN. BEND RADIUS "R"	MIN. BEND SPACE "L"
26AWG	11.4MM	55MM	105MM

Mechanical Structure Characteristics of Plug

- Raw Cable -- Support 26~30AWG, 100ohm, Silver plated, vw-1, RoHS2.0.
- PCB --High Speed Very low loss material M6,8 Layers Design; Gold finger plated gold 30u" min., nickel plated 150~700u"; pad: immersion gold 1u" min., nickel plated 100u"min. 94v-0, RoHS2.0;
- Upper shell -- Zinc Die-cast, with Cu plated 280u" min. overall and Ni plated 120u" min.
- Bottom shell -- Zinc Die-cast, with Cu plated 280u" min. overall and Ni plated 120u" min.
- Latch-- Stainless steel, SUS304 + PA66 CM3004, black;
- Spring -- Stainless steel, SUS301EH;
- Rivet -- Stainless Steel, SUS304;
- SR (Strain Relief) -- PVC, 45P, BLACK, RoHS2.0.
- Dust Cover—PVC, 60P, Blue, ANTI-STATIC, RoHS2.0.

2-Wires EEPROM Interface

The QSFP-DD passive cable EEPROM is compliant with CMIS3.0 specification. Each connector contains a 256 bytes EEPROM at device address A0(h). The information for addresses 0 to 255 is listed below.

A0h Address	Name	Value	Description
0	Identifier	18	Type of Serial Module -- See SFF-8024,19h: OSFP 8X Pluggable Transceiver
1	Version ID	30	the upper nibble is the whole number part and the lower nibble is the decimal part. Example: 21h indicates version 2.1.
2	Flat_mem	80	Upper memory flat or paged.0b=Paged memory 1b=Flat memory (only page 00h implemented)
	CLEI present		CLEI code present in upper page 00h
	Reserved		Reserved
	TWI Maximum speed		Indicates maximum two-wire serial speed supported by module 00b=Module supports up to 400 KHz 01b=Module supports up to 1 MHz 10b=Reserved 11b=Reserved
	Reserved		Reserved
3	Reserved	03	Reserved
	Module state		Current state of Module 001b: ModuleLowPwr state (Flat memory passive cable assemblies)
	Interrupt		Digital state of IntL Interrupt output signal 0b=IntL asserted 1b=IntL not asserted (default)
4~7	Bank 0 lane flag	00	Indicates that one or more of the flag bits from bank 0
8	Reserved	00	Reserved
	Module state changed flag		Indicates change of Module state
9~13	Module Interrupt Flags	00	Module Interrupt Flags
14~25	Module monitors	00	Module monitors Temperature MSB
26~30	Module Global Controls	00	ForceLowPwr,Software Reset,Custom
31~36	Module Level Flag Masks	00	Module Level Flag Masks
37~63	Reserved	00	Reserved
64~84	Custom	00	Custom
85	Module Type Encodings	03	00h: Undefined 01h: Optical Interfaces: MMF 02h: Optical interfaces: SMF 03h: Passive Cu 04h: Active Cable 005: Base-T
86	Module Host Electrical interface codes (ApSel:0001b)	1D	1A:100GBASE-CR4 NRZ 1D:400G CR8 PAM4
87	Module Media interface codes (ApSel:0001b)	01	01: Copper cable
88	Host/Media Lane Count (ApSel:0001b)	88	7-4: Host Lane Count 3-0: Media Lane Count
89	Lane Assignment (ApSel:0001b)	00	code 1: if application is allowed on a given host lane. bits 0-7 correspond to host lanes 1-8
90	Module Host Electrical interface codes (ApSel:0010b)	00	Module Host-Media Interface Advertising Codes
91	Module Media interface	00	Module Host-Media Interface Advertising Codes

	codes (ApSel:0010b)		
92	Host/Media Lane Count (ApSel:0010b)	00	Module Host-Media Interface Advertising Codes
93	Lane Assignment (ApSel:0010b)	00	Module Host-Media Interface Advertising Codes
94	Module Host Electrical interface codes (ApSel:0011b)	00	Module Host-Media Interface Advertising Codes
95	Module Media interface codes (ApSel:0011b)	00	Module Host-Media Interface Advertising Codes
96	Host/Media Lane Count (ApSel:0011b)	00	Module Host-Media Interface Advertising Codes
97	Lane Assignment (ApSel:0011b)	00	Module Host-Media Interface Advertising Codes
98	Module Host Electrical interface codes (ApSel:0100b)	00	Module Host-Media Interface Advertising Codes
99	Module Media interface codes (ApSel:0100b)	00	Module Host-Media Interface Advertising Codes
100	Host/Media Lane Count (ApSel:0100b)	00	Module Host-Media Interface Advertising Codes
101	Lane Assignment (ApSel:0100b)	00	Module Host-Media Interface Advertising Codes
102	Module Host Electrical interface codes (ApSel:0101b)	00	Module Host-Media Interface Advertising Codes
103	Module Media interface codes (ApSel:0101b)	00	Module Host-Media Interface Advertising Codes
104	Host/Media Lane Count (ApSel:0101b)	00	Module Host-Media Interface Advertising Codes
105	Lane Assignment (ApSel:0101b)	00	Module Host-Media Interface Advertising Codes
106	Module Host Electrical interface codes (ApSel:0110b)	00	Module Host-Media Interface Advertising Codes
107	Module Media interface codes (ApSel:0110b)	00	Module Host-Media Interface Advertising Codes
108	Host/Media Lane Count (ApSel:0110b)	00	Module Host-Media Interface Advertising Codes
109	Lane Assignment (ApSel:0110b)	00	Module Host-Media Interface Advertising Codes
110	Module Host Electrical interface codes (ApSel:0111b)	00	Module Host-Media Interface Advertising Codes
111	Module Media interface codes (ApSel:0111b)	00	Module Host-Media Interface Advertising Codes
112	Host/Media Lane Count (ApSel:0111b)	00	Module Host-Media Interface Advertising Codes
113	Lane Assignment (ApSel:0111b)	00	Module Host-Media Interface Advertising Codes
114	Module Host Electrical interface codes (ApSel:1000b)	00	Module Host-Media Interface Advertising Codes
115	Module Media interface codes (ApSel:1000b)	00	Module Host-Media Interface Advertising Codes
116	Host/Media Lane Count (ApSel:1000b)	00	Module Host-Media Interface Advertising Codes
117	Lane Assignment (ApSel:1000b)	00	Module Host-Media Interface Advertising Codes
118~125	Password Entry and Change	00	Password Entry and Change
126	Bank Select Byte	00	The module shall ignore the Bank Select byte if the Page Select byte is outside of the 10h to 1Fh range (inclusive). In this case the Bank Select byte shall revert to bank 0 and read/write operations shall be to bank 0.
127	Page Select Byte	00	Writing the value of a non-supported page shall not be accepted by the module. In such cases the Page Select byte shall revert to 0 and read/write operations shall be to upper page 00h.

128	Identifier	18	Identifier Type of Module
129~144	Vendor name	*	Vendor name (ASCII)
145	Vendor OUI	3C	Vendor IEEE company ID
146		18	
147		A0	
148~163	Vendor PN	*	Part number provided by vendor
164	Vendor rev	41	Vendor rev A
165		20	Vendor rev A
166~181	Vendor SN	*	Vendor Serial Number (ASCII)
182~189	Date code	*	Date code (ASCII)
190~199	CLEI code	00	Common Language Equipment Identification code
200	Module Card Power Class	00	000: Power class 1; 001: Power class 2 010: Power class 3; 011: Power class 4 100: Power class 5; 101: Power class 6 110: Power class 7; 111: Power class 8
201	Max Power	06	Maximum power consumption in multiples of 0.25 W rounded up to the next whole multiple of 0.25 W
202	Cable assembly Length multiplier field	*	Multiplier for value in bits 5-0. 00 = multiplier of .1 01 = multiplier of 1 10 = multiplier of 10 11 = multiplier of 100
	Cable assembly Length Base Length field		Link length base value. To calculate actual link length use multiplier in bits 7-6.
203	Media connector Type	23	Type of connector present in the module. See SFF-8024 for codes. 23h: Non-separable Connector
204	Copper cable Attenuation 5GHz	*	Passive copper cable attenuation at 5 GHz in 1 dB increments
205	Copper cable Attenuation 7GHz	*	Passive copper cable attenuation at 7 GHz in 1 dB increments
206	Copper cable Attenuation 12.89GHz	*	Passive copper cable attenuation at 12.89 GHz in 1 dB increments
207	Copper cable Attenuation 25.8GHz	*	Passive copper cable attenuation at 25.8 GHz in 1 dB increments
208	Reserved	00	Reserved
209	Reserved	00	Reserved
210	Near end implementation lane 8	00	0b=Lane 8 implemented in near end 1b=Lane 8 not implemented in near end
211	Reserved	02	Reserved
	Implemented lanes in far end		See Table for config code of discrete far end connectors
212	Media interface technology	0A	0A: Copper cable unequalized
213~220	Reserved	00	Reserved
221	Custom	00	Custom
222	Checksum	*	Include bytes 128-221
223~251	User custom info NV	00	User custom info NV
252~255	User custom info NV	00	User custom info NV

Pin Descriptions

PIN	Logic	Symbol	Description	Notes
1		GND	Ground	1
2	CML-I	Tx2n	Transmitter Inverted Data Input	
3	CML-I	Tx2p	Transmitter Non-Inverted Data Input	
4		GND	Ground	1
5	CML-I	Tx4n	Transmitter Inverted Data Input	
6	CML-I	Tx4p	Transmitter Non-Inverted Data Input	
7		GND	Ground	1
8	LVTTTL-I	ModSelL	Module Select	
9	LVTTTL-I	ResetL	Module Reset	
10		VccRx	+3.3V Power Supply Receiver	2
11	LVC MOS-I/O	SCL	2-wire serial interface clock	
12	LVC MOS-I/O	SDA	2-wire serial interface data	
13		GND	Ground	1
14	CML-O	Rx3p	Receiver Non-Inverted Data Output	
15	CML-O	Rx3n	Receiver Inverted Data Output	
16		GND	Ground	1
17	CML-O	Rx1p	Receiver Non-Inverted Data Output	
18	CML-O	Rx1n	Receiver Inverted Data Output	
19		GND	Ground	1
20		GND	Ground	1
21	CML-O	Rx2n	Receiver Inverted Data Output	
22	CML-O	Rx2p	Receiver Non-Inverted Data Output	
23		GND	Ground	1
24	CML-O	Rx4n	Receiver Inverted Data Output	
25	CML-O	Rx4p	Receiver Non-Inverted Data Output	
26		GND	Ground	1
27	LVTTTL-O	ModPrsL	Module Present	
28	LVTTTL-O	IntL	Interrupt	
29		VccTx	+3.3V Power Supply Transmitter	2
30		Vccl	+3.3V Power Supply	2
31	LVTTTL-I	InitMode	Initialization mode; In legacy QSFP applications, the InitMode pad is called LPMODE	
32		GND	Ground	1
33	CML-I	Tx3p	Transmitter Non-Inverted Data Input	
34	CML-I	Tx3n	Transmitter Inverted Data Input	
35		GND	Ground	1
36	CML-I	Tx1p	Transmitter Non-Inverted Data Input	
37	CML-I	Tx1n	Transmitter Inverted Data Input	
38		GND	Ground	1

PIN		Symbol	Description	Notes
39		GND	Ground	1
40	CML-I	Tx6n	Transmitter Inverted Data Input	
41	CML-I	Tx6p	Transmitter Non-Inverted Data Input	
42		GND	Ground	1
43	CML-I	Tx8n	Transmitter Inverted Data Input	
44	CML-I	Tx8p	Transmitter Non-Inverted Data Input	
45		GND	Ground	1
46		Reserved	For future use	3
47		VSI	Module Vendor Specific 1	3
48		VccRx1	3.3V Power Supply	2
49		VS2	Module Vendor Specific 2	3
50		VS3	Module Vendor Specific 3	3
51		GND	Ground	1
52	CML-O	Rx7p	Receiver Non-Inverted Data Output	
53	CML-O	Rx7n	Receiver Inverted Data Output	
54		GND	Ground	1
55	CML-O	Rx5p	Receiver Non-Inverted Data Output	
56	CML-O	Rx5n	Receiver Inverted Data Output	
57		GND	Ground	1
58		GND	Ground	1
59	CML-O	Rx6n	Receiver Inverted Data Output	
60	CML-O	Rx6p	Receiver Non-Inverted Data Output	
61		GND	Ground	1
62	CML-O	Rx8n	Receiver Inverted Data Output	
63	CML-O	Rx8p	Receiver Non-Inverted Data Output	
64		GND	Ground	1
65		NC	No Connect	3
66		Reserved	For future use	3
67		VccTx1	3.3V Power Supply	2
68		Vcc2	3.3V Power Supply	2
69		Reserved	For future use	3
70		GND	Ground	1
71	CML-I	Tx7p	Transmitter Non-Inverted Data Input	
72	CML-I	Tx7n	Transmitter Inverted Data Input	
73		GND	Ground	1
74	CML-I	Tx5p	Transmitter Non-Inverted Data Input	
75	CML-I	Tx5n	Transmitter Inverted Data Input	
76		GND	Ground	1

Notes:

1. QSFP-DD uses common ground (GND)for all signals and supply (power). All are common within the QSFP-DD module and all module voltages are referenced to this potential unless otherwise noted. Connect these directly to the host board signal-common ground plane.
2. VccRx, VccRx1, Vcc1, Vcc2, VccTx and VccTx1 shall be applied concurrently. Requirements defined for the host side of the Host Card Edge Connector are listed in Table 6. VccRx, VccRx1, Vcc1, Vcc2, VccTx and VccTx1 may be internally connected within the module in any combination. The connector Vcc pins are each rated for a maximum current of 1000 mA.
3. All Vendor Specific, Reserved and No Connect pins may be terminated with 50 ohms to ground on the host. Pad 65 (No Connect) shall be left unconnected within the module. Vendor specific and Reserved pads shall have an impedance to GND that is greater than 10 kOhms and less than 100 pF.
4. Plug Sequence specifies the mating sequence of the host connector and module. The sequence is 1A, 2A, 3A, 1B, 2B, 3B. (see Figure 2 for pad locations) Contact sequence A will make, then break contact with additional QSFP-DD pads. Sequence 1A, 1B will then occur simultaneously, followed by 2A, 2B, followed by 3A,3B.

Electrical Pin-out Details

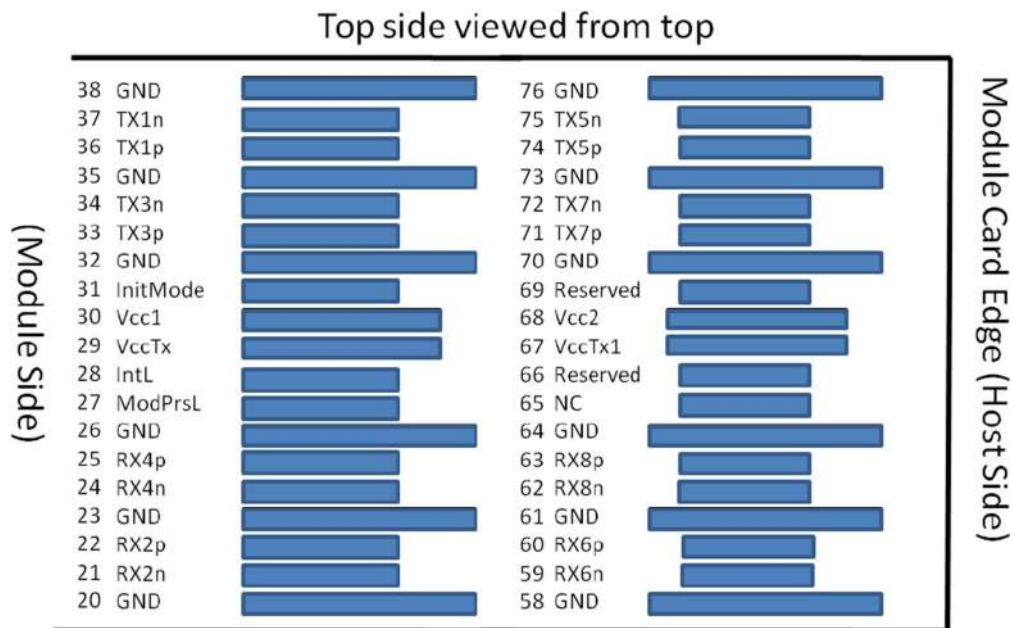

Bottom side viewed from bottom

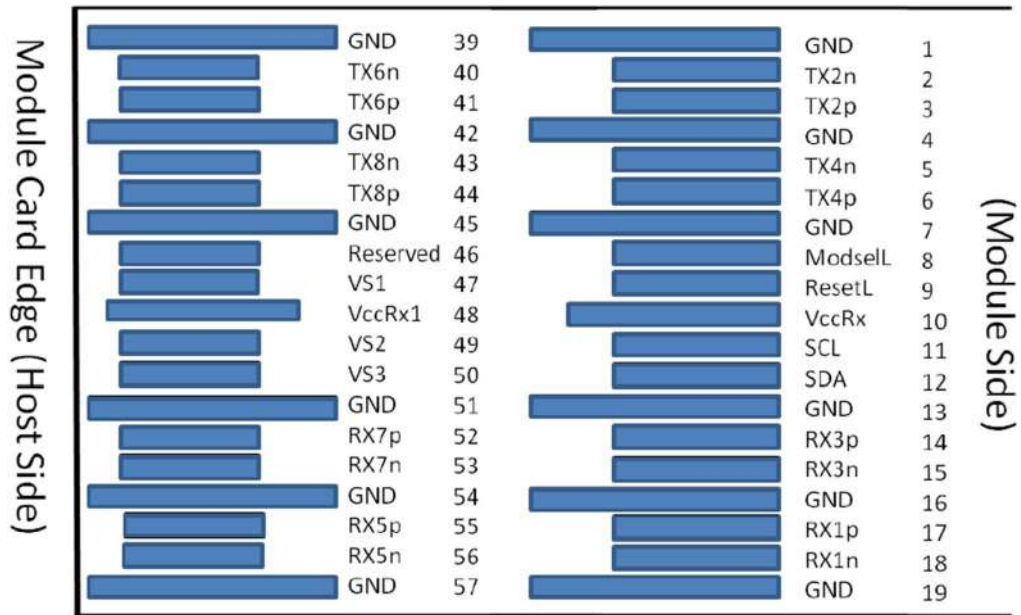

Mechanical Specifications

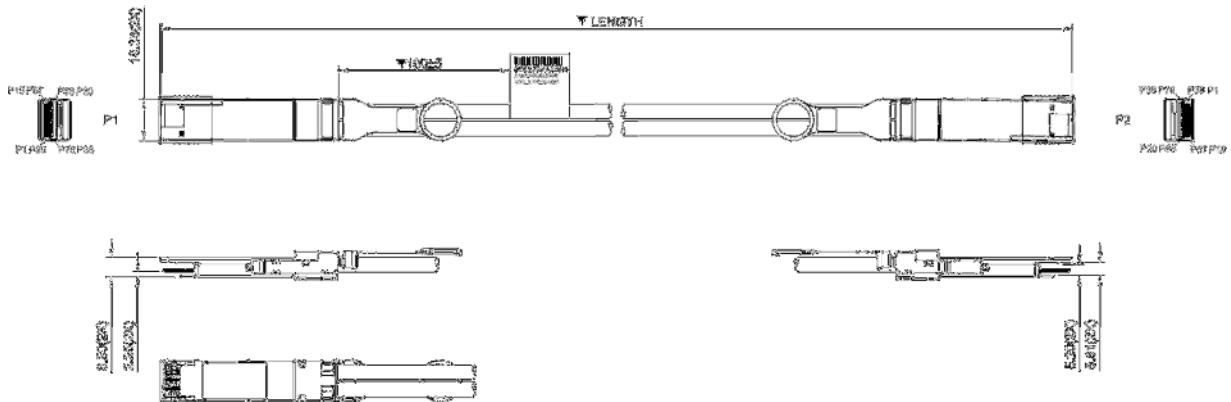

Electrical Test Characteristics

Item		Requirement	Test Condition
Differential Impedance	Cable Impedance	100 +10/-5 Ω	Rise time of 30ps (at the SMA) (20 % - 80 %).
	Paddle Card Impedance	100 ± 10 Ω	
	Cable Termination Impedance	100 +10 / -15 Ω	
Differential (Input/Output) Return loss SDD11/SDD22		$\text{Return_loss}(f) \geq \begin{cases} 16.5-2\sqrt{f} & 0.05 \leq f < 4.1 \\ 10.66-14\log_{10}(f/5.5) & 4.1 \leq f \leq 19 \end{cases}$ <p>Where f is the frequency in GHz Return loss(f) is the return loss at frequency f</p>	10MHz ≤ f ≤ 26.5GHz
Differential to common-mode (Input/Output) Return loss SCD11/SCD22		$\text{Return_loss}(f) \geq \begin{cases} 22-(20/25.78) f & 0.01 \leq f < 12.85 \\ 15-(6/25.78) f & 12.89 \leq f \leq 19 \end{cases}$ <p>Where f is the frequency in GHz Return_loss(f) is the Differential to common-mode return loss at frequency f</p>	10MHz ≤ f ≤ 26.5GHz
Common-mode to Common-mode (Input/Output) Return loss SCC11/SCC22		$\text{Return_loss}(f) \geq 2\text{dB} \quad 0.2 \leq f \leq 19$ <p>Where f is the frequency in GHz Return_loss(f) is the common-mode to common-mode return loss at frequency f</p>	10MHz ≤ f ≤ 26.5GHz
Differential Insertion Loss		(Differential Insertion Loss Max. For TPa to TPb Including Test fixture)	10MHz ≤ f ≤ 19GHz
		Passive Cable: -17.16dB Min. @13.28GHz	10MHz ≤ f ≤ 26.5GHz
Differential to common-mode			10MHz ≤ f ≤ 26.5GHz
Conversion Loss-Differential Insertion Loss (SCD21-SD22)		$\text{Conversion_loss}(f) - \text{IL}(f) \geq \begin{cases} 10 & 0.01 \leq f < 12.89 \\ 27-(29/22) f & 12.89 \leq f < 15.7 \\ 6.3 & 15.7 \leq f \leq 19 \end{cases}$ <p>Where f is the frequency in GHz Conversion_loss (f) is the cable assembly differential to common-mode conversion loss IL(f) is the cable assembly insertion loss</p>	
ICN		<p>a is the IL@13.28GHz</p> $3 \leq a \leq 7.65: 9 \text{ mV Max}$ $7.65 \leq a \leq 26: 12.75 - 0.49 * a \text{ mV Max}$	10MHz ≤ f ≤ 26.5GHz

Other Electrical Performance Requirement

Item	Description	Test condition	Judgment
3.2.1	Insulation Resistance	EIA-364-21, DC 300V 1 minute.	Meet Spec. 10M ohm (Min.)
3.2.2	Dielectric Withstanding Voltage	EIA-364-20, apply a voltage of 300V DC for 1 minute between adjacent terminals, and between adjacent terminals and ground.	Meet Spec. NO disruptive discharge.
3.2.3	Low Level Contact Resistance (LLCR)	EIA-364-23, apply a maximum voltage of 20mV and a current of 100mA.	Meet Spec. 70 milliohms Max. From initial.
3.2.4	Continuity	Verify the continuous electrical path of all expected connections	No unexpected opens, shorts, or high resistance areas.

Mechanical Test Characteristics

#	Item	Industry Spec	Test Condition	Requirement
3.3.1	Vibration	EIA-364-28	Clamp & vibrate per EIA-364-28F,TC-VII, Test condition letter – D, 15 minutes in X, Y & Z axis.	No evidence of physical damage
3.3.2	Mechanical Shock	EIA-364-27C	Clamp and Shock per EIA-364-27C, TC-G,3 times in 6 directions, 100g, 6ms	No evidence of physical damage
3.3.3	Cable Flex	EIA-364-41C	Flex cable 180° for 20 cycles (±90° from nominal position) at 12 cycles per minute with a 1.0kg load applied to the cable jacket. Flex in the boot area 90° in each direction from vertical. Per EIA-364-41C	No evidence of physical damage
3.3.4	Cable Plug Retention in Cage	EIA-364-38B	Cable plug is clamped with the cable hanging vertically. A 90N load is applied (gradually) to the cable jacket for a 1-minute duration. Force to be applied axially with no damage to plug latch. Per EIA-364-38B	90N Min. No evidence of physical damage per QSFP-DD MSA
3.3.5	Cable Retention in Plug	EIA-364-38B	Cable plug is fixtured with the bulk cable hanging vertically. A 90N axial load is applied (gradually) to the cable jacket and held for 1 minute. Per EIA-364-38B	90N Min. No evidence of physical damage
3.3.6	Cable Plug Insertion	EIA-364-13B	Per EIA-364-13B	90N Max per QSFP-DD MSA
3.3.7	Cable Plug Extraction	EIA-364-13B	Place axial load on latch pull to de-latch plug. Per EIA-364-13B,	30N Max. per QSFP-DD MSA
3.3.8	Latch Pull Strength	EIA-364-38B	Per EIA-364-38B	90N Min. No evidence of physical damage
3.3.9	Durability	EIA-364-09	EIA-364-09, perform plug & unplug cycles: Plug and receptacle mate rate: 250times/hour. 50times for QSFP-DD module (CONNECTOR TO PCB)	50 cycles, No evidence of physical damage

Environmental Test Characteristics

#	Item	Industry Spec	Test condition	Requirement
3.4.1	Operating Temperature	/	Cable operating temperature range.	-20°C to +80°
3.4.2	Storage Temp. Range (in packed condition)	/	Cable storage temp. range in packed condition.	-40°C to +80°C
3.4.3	Thermal Shock	EIA-364-32D	EIA-364-32D: method A, TC-1, -55°C to 85°C,100 cycles	1. No Physical Damage 2. MeetΔLLCR 3. Meet 3.1 SDD21
3.4.4	Cyclic Temperature& Humidity	EIA-364-31	EIA-364-31 Method III, Test condition B	1. No Physical Damage 2. MeetΔLLCR 3. Meet 3.1 SDD21
3.4.5	Salt spraying	EIA-364-26B	48 hours salt spraying after shell corrosive area less than 5%	no physical crack
3.4.6	Mixed Flowing Gas	EIA-364-65	EIA-364-65 Class IIA 14 days	1. MeetΔLLCR 2. Meet 3.1 SDD21
3.4.7	Temperature Life	EIA-364-17B	EIA-364-17B, With 85±2°C and 85±2% RH condition for 500 hours	1. No Physical Damage 2. MeetΔLLCR 3. Meet 3.1 SDD21 stressing
3.4.8	Cold bend	/	Condition: -20°C±2°C, mandrel diameter is 6 times the cable diameter.	4h, no physical crack
3.4.9	Flame Retardant Grade	VW-1	/	VW-1

About ProLabs

Our experience comes as standard; for over 15 years ProLabs has delivered optical connectivity solutions that give our customers freedom and choice through our ability to provide seamless interoperability. At the heart of our company is the ability to provide state-of-the-art optical transport and connectivity solutions that are compatible with over 90 optical switching and transport platforms.

Complete Portfolio of Network Solutions

ProLabs is focused on innovations in optical transport and connectivity. The combination of our knowledge of optics and networking equipment enables ProLabs to be your single source for optical transport and connectivity solutions from 100Mb to 400G while providing innovative solutions that increase network efficiency. We provide the optical connectivity expertise that is compatible with and enhances your switching and transport equipment.

Trusted Partner

Customer service is our number one value. ProLabs has invested in people, labs and manufacturing capacity to ensure that you get immediate answers to your questions and compatible product when needed. With Engineering and Manufacturing offices in the U.K. and U.S. augmented by field offices throughout the U.S., U.K. and Asia, ProLabs is able to be our customers best advocate 24 hours a day.

Contact Information

ProLabs US

Email: sales@prolabs.com

Telephone: 952-852-0252

ProLabs UK

Email: salessupport@prolabs.com

Telephone: +44 1285 719 600