

MATERIAL NUMBER	OLD PART NUMBER
120115-0017	702P401

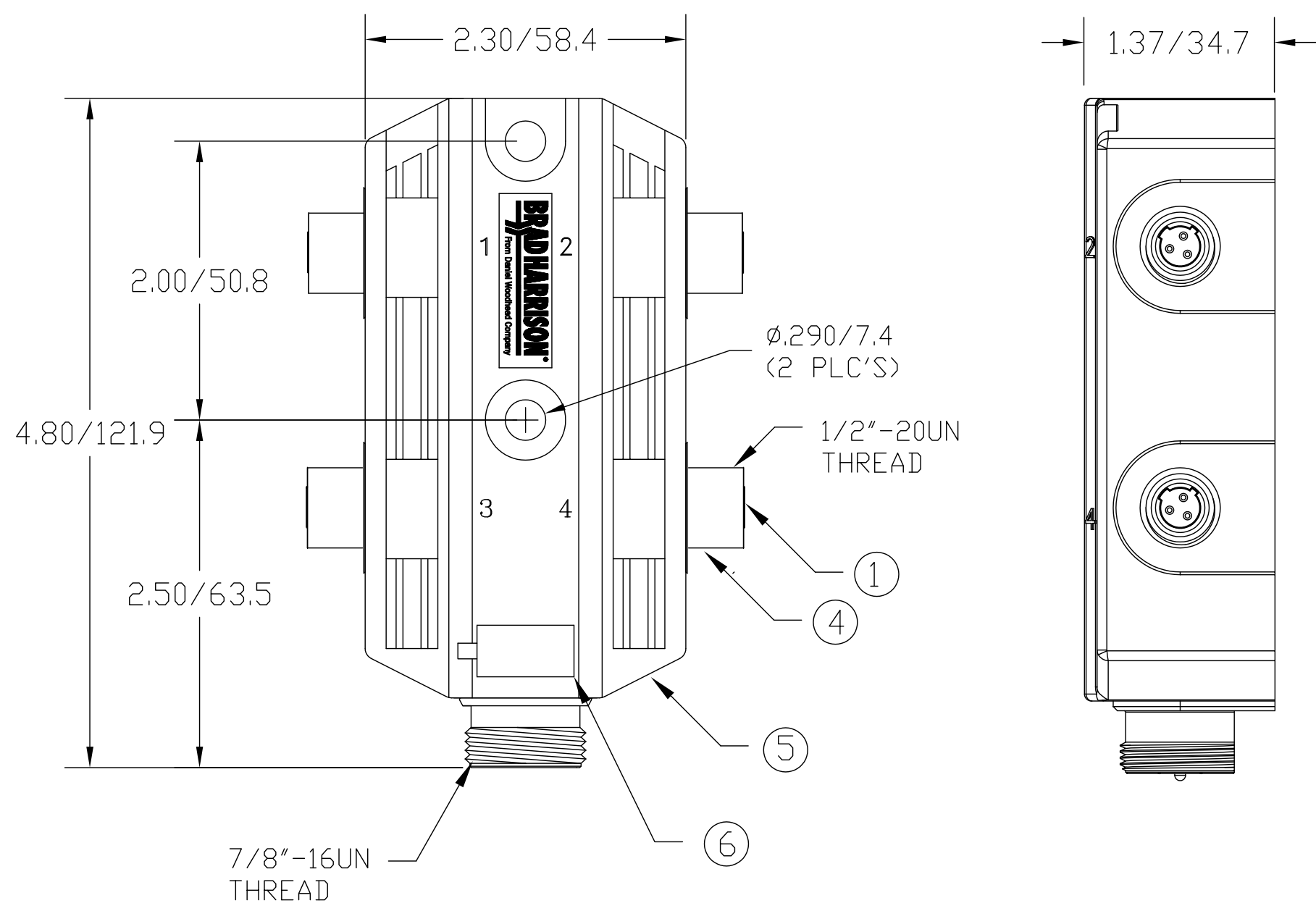

SCHEMATIC

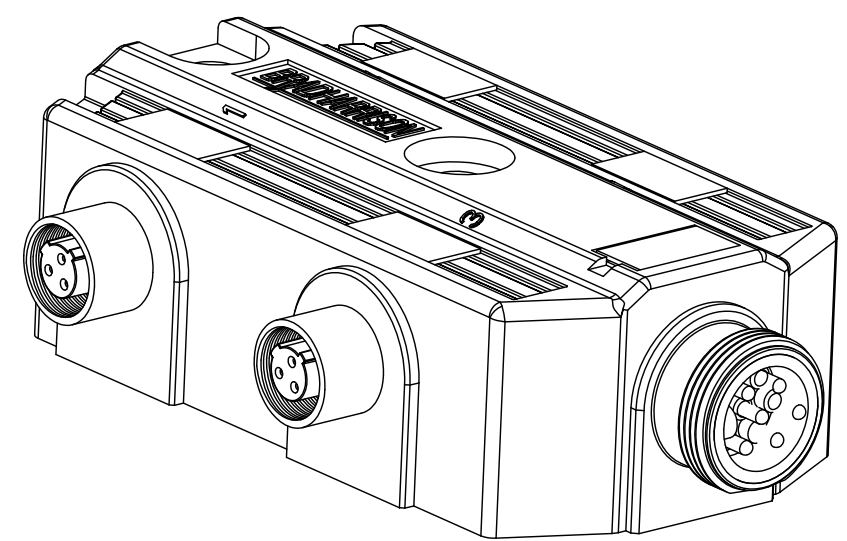
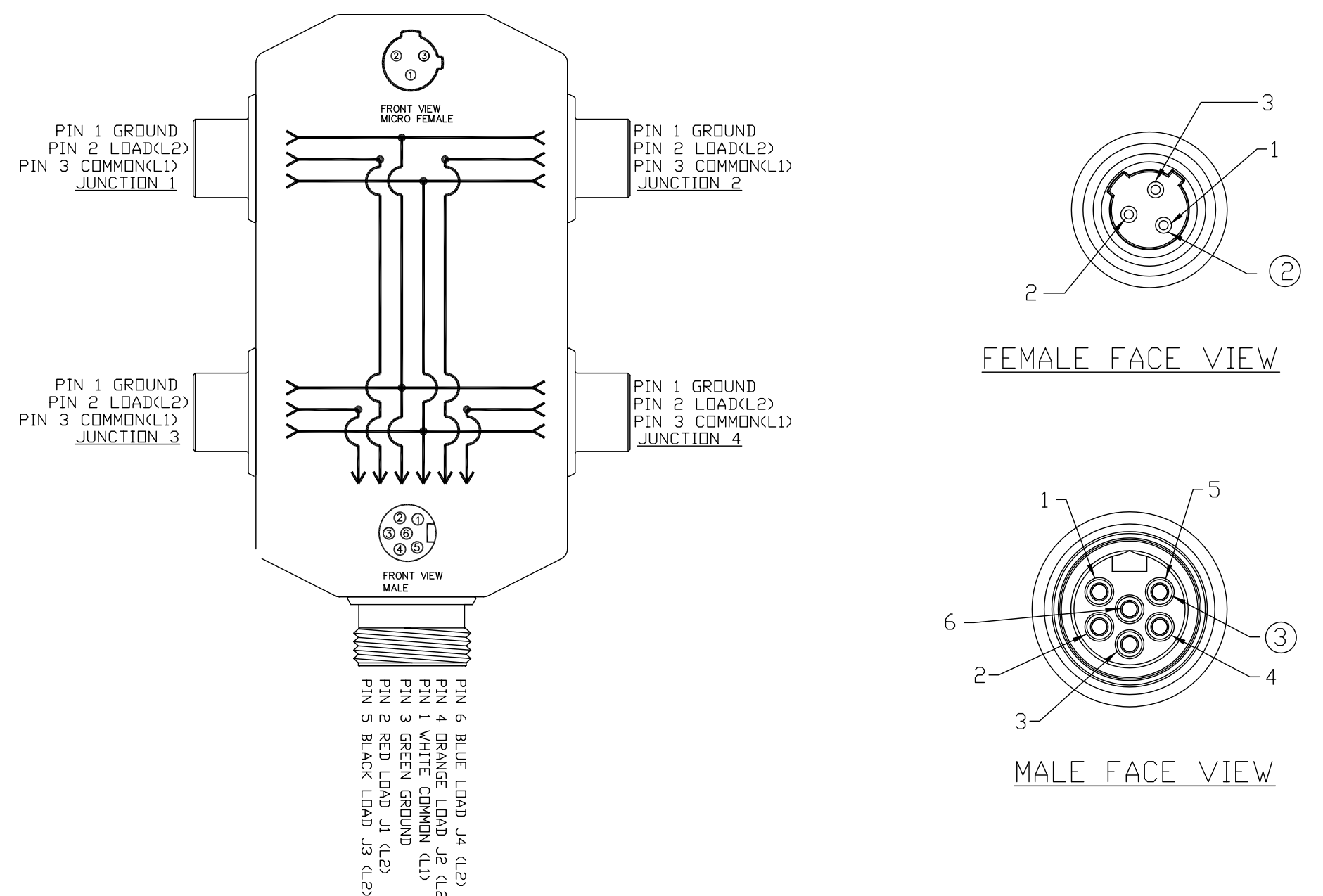

VOLTAGE RATING	120 VAC/VDC
AMPERAGE RATING PER PORT	4 AMPS
AMPERAGE RATING PER UNIT	8 AMPS
PROTECTION	IP67
OPERATING TEMPERATURE	-25°C TO 90°C

ITEM	COMPONENT	MATERIAL	FINISH
1	INSERT	NLYON	BLACK
2	CONTACT SOCKET	COPPER ALLOY	GOLD OVER NICKEL
3	CONTACT PIN	COPPER ALLOY	GOLD OVER NICKEL
4	RECEPTACLE SHELL	ZINC DIE CAST	BLACK E-COATED
5	HOUSING	PBT	BLACK
6	LABEL	ABS	WHITE
	POTTING MATERIAL	EPOXY	AMBER

DK PINOUT, EPOXY COLOR EC NO: WEU2010-0200 DRWN: VOU 11/23/09 CH'KD: TWOLDEGE 2009/12/1 APPR: JFMURPHY 2009/12/15	QUALITY SYMBOL ▽=0 ◻=0
	DESCRIPTION

GENERAL TOLERANCES (UNLESS SPECIFIED) 4 PLACES ±--- 3 PLACES ±--- 2 PLACES ±--- 1 PLACE ±0.3	DIMENSION STYLE IN/MM
	SCALE ---

DRAWN BY BW	DATE 2009/03/26
CHECKED BY LH	DATE 2009/03/26
APPROVED BY JFMURPHY	DATE 2009/12/15
MATERIAL NO. SEE CHART	DOCUMENT NO. SD-120115-001

THIRD ANGLE PROJECTION
TITLE MICRO DUALKEY 4 PORT 3 POLE MPIS
MOLEX INCORPORATED
SHEET NO. 1 OF 1