

TLE4998P8(D)

High Performance Programmable Single/Dual Linear Hall Sensor

Data Sheet

Revision 1.1, 2017-01

Edition 2017-01

**Published by
Infineon Technologies AG
81726 Munich, Germany**

**© 2017 Infineon Technologies AG
All Rights Reserved.**

Legal Disclaimer

The information given in this document shall in no event be regarded as a guarantee of conditions or characteristics. With respect to any examples or hints given herein, any typical values stated herein and/or any information regarding the application of the device, Infineon Technologies hereby disclaims any and all warranties and liabilities of any kind, including without limitation, warranties of non-infringement of intellectual property rights of any third party.

Information

For further information on technology, delivery terms and conditions and prices, please contact the nearest Infineon Technologies Office (www.infineon.com).

Warnings

Due to technical requirements, components may contain dangerous substances. For information on the types in question, please contact the nearest Infineon Technologies Office.

Infineon Technologies components may be used in life-support devices or systems only with the express written approval of Infineon Technologies, if a failure of such components can reasonably be expected to cause the failure of that life-support device or system or to affect the safety or effectiveness of that device or system. Life support devices or systems are intended to be implanted in the human body or to support and/or maintain and sustain and/or protect human life. If they fail, it is reasonable to assume that the health of the user or other persons may be endangered.

Table of Contents

	Table of Contents	3
1	Overview	4
1.1	Features	4
1.2	Target Applications	5
1.3	Pin Configuration	5
2	General	6
2.1	Block Diagram	6
2.2	Functional Description	6
2.3	Principle of Operation	7
2.4	Transfer Functions	7
3	Maximum Ratings	8
4	Operating Range	9
5	Electrical, Thermal and Magnetic Parameters	10
5.1	Electrical Characteristics	10
5.2	Magnetic Characteristics	11
5.3	Electrical and Magnetic Characteristics in Undervoltage Range	12
5.4	Magnetic Field Direction Definition	12
6	Application Circuit	13
7	Configuration and Calibration Parameters	14
8	Error Detection	16
8.1	Voltages Outside the Operating Range	16
8.2	EEPROM Error Correction	16
9	PG-TDSO-8 Package Outlines	17
9.1	Distance Chip to package	17
9.2	Moisture Sensitivity Level (MSL)	17
9.3	PG-TDSO-8 Package Marking	18

1 Overview



Characteristic	Supply Voltage	Supply Current	Magnetic Range	Interface	Temperature
Programmable Single/Dual Die Linear Hall Sensor	4.5~5.5 V	6 mA	±50mT ±100mT ±200mT	PWM Open Drain Output	-40°C to 125°C



Figure 1-1 SMD package PG-TDSO-8 for the TLE4998P8(D)

1.1 Features

- Integration of two individual programmable Linear Hall sensor IC's with PWM open-drain output signal
- 20-bit Digital Signal Processing
- Digital temperature and stress compensation
- 12-bit overall resolution
- Operating automotive temperature range -40°C to 125°C
- Minimal drift of output signal over temperature and lifetime
- Programmable parameters stored in EEPROM with single bit error correction:
 - PWM output frequency
 - Magnetic range, sensitivity (gain), offset, and polarity of the output slope
 - Bandwidth
 - Clamping levels
 - Customer temperature compensation coefficients for all common magnets
- Re-programmable until memory lock
- Supply voltage 4.5 - 5.5 V (4.1 - 16 V extended range)
- Configurable magnetic range: ±50 mT, ±100 mT, or ±200 mT
- Reverse-polarity and overvoltage protection for all pins
- Output short-circuit protection
- On-board diagnostics (overvoltage, EEPROM error)
- Digital readout of the magnetic field and internal temperature in calibration mode
- Programming and operation of multiple sensors with common power supply
- Two-point calibration of magnetic transfer function without iteration steps

Note: Product qualification is based on "AEC Q100 Rev. G" grade 1 (Automotive Electronics Council - Stress test qualification for integrated circuits)

Table 1-1 Ordering Information

Product Name	Marking	Ordering Code	Package
TLE4998P8	P8S	SP000902772	single sensor, PG-TDSO-8-1
TLE4998P8D	P8D	SP000902776	dual sensor, PG-TDSO-8-2

1.2 Target Applications

- Robust replacement of potentiometers: No mechanical abrasion, resistant to humidity, temperature, pollution and vibration
- Linear and angular position sensing in automotive and industrial applications with highest accuracy requirements
- Suited for safety applications such as pedal position, throttle position and steering torque sensing

1.3 Pin Configuration

Figure 1-2 shows the location of the Hall elements in the package and the pin configuration of the TLE4998P8(D).

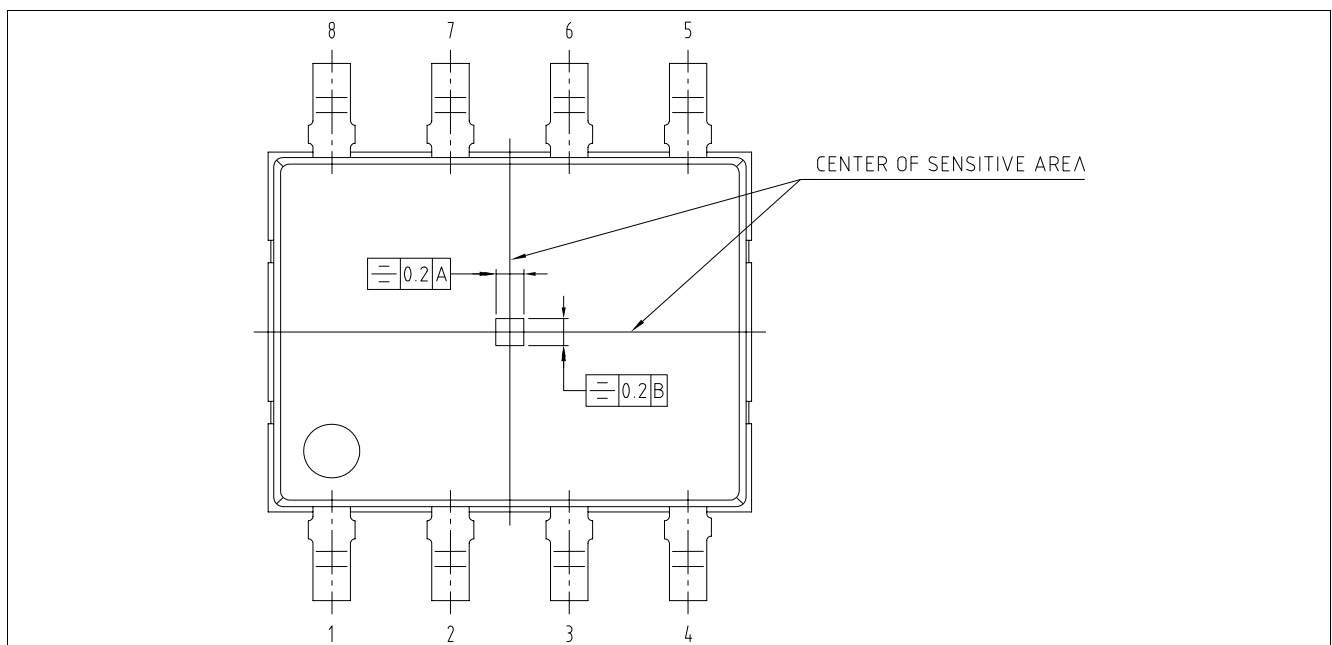

Figure 1-2 Pin Configuration of PG-TDSO-8 Package

Table 1-2 TLE4998P8(D) Pin Definitions and Functions

Pin No.	Symbol	TLE4998P8 Function	TLE4998P8D Function
1	TST	Test pin (connection to GND is recommended)	Test pin (top die, connection to GND is recommended)
2	V_{DD}	Supply voltage / programming interface	Supply voltage / programming interface (top die)
3	GND	Ground	Ground (top die)
4	OUT	Output / programming interface	Output / programming interface (top die)
5	OUT	Not connected	Output / programming interface (bottom die)
6	GND	Not connected	Ground (bottom die)
7	V_{DD}	Not connected	Supply voltage / programming interface (bottom die)
8	TST	Not connected	Test pin (bottom die, connection to GND is recommended)

2 General

All further given specifications are regarded to both implemented sensor IC's, or otherwise noted.

2.1 Block Diagram

Figure 2-1 shows is a simplified block diagram.

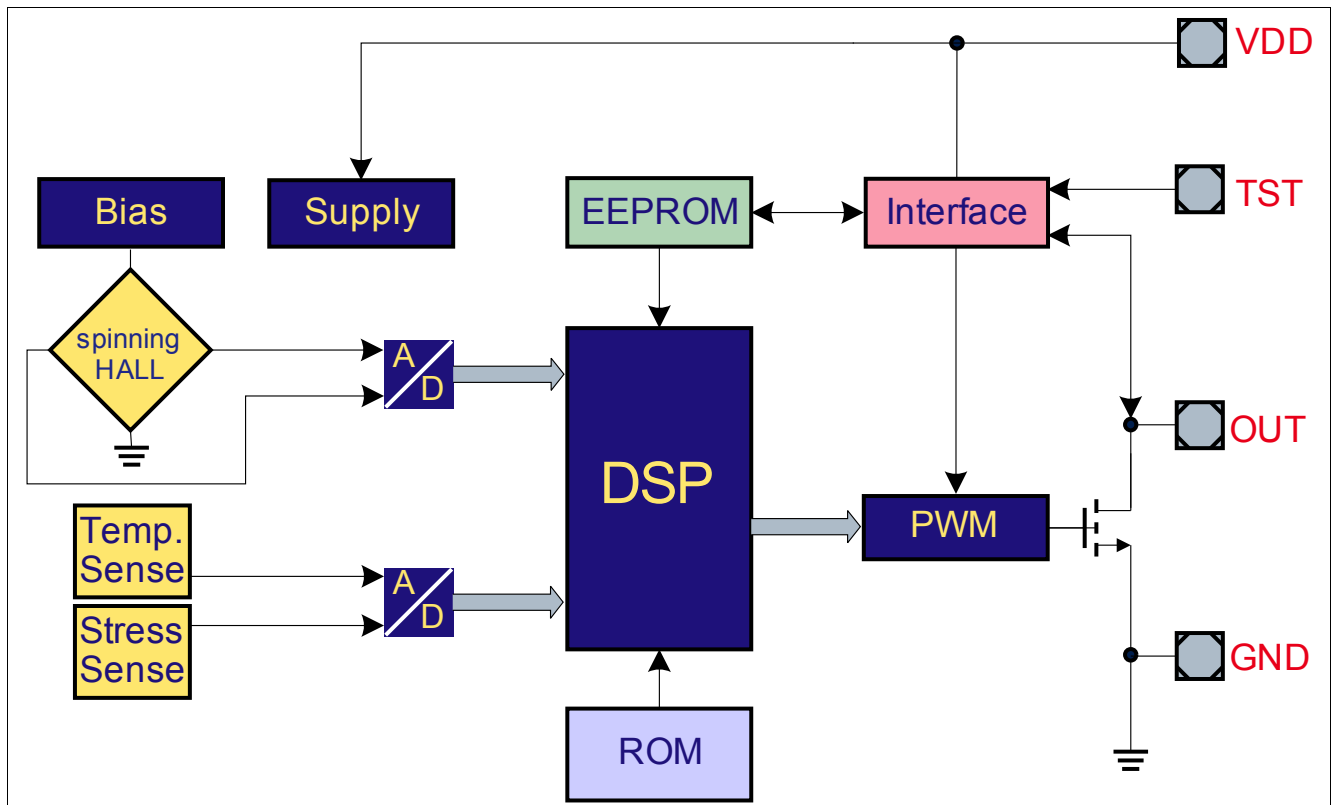

Figure 2-1 Block Diagram of the TLE4998P8(D) with the PWM interface

2.2 Functional Description

The linear Hall IC TLE4998P8(D) has been designed specifically to meet the requirements of highly accurate angle and position detection.

The sensor provides a digital PWM signal, which is well suited for direct decoding by any unit measuring a duty cycle of a rectangular signal (usually a timer/capture unit in a microcontroller).

The output stage is an open-drain driver pulling the output pin to low only. Therefore, the high level needs to be obtained by an external pull-up resistor. This output type has the advantage that the receiver may use an even lower supply voltage (e.g. 3.3 V). In this case the pull-up resistor must be connected to the given receiver supply.

The IC is produced in BiCMOS technology with high voltage capability and it also has reverse-polarity protection.

Digital signal processing using a 16-bit DSP architecture together with digital temperature and stress compensation guarantees excellent stability over the whole temperature range and life time.

The PWM output frequency can be selected within the range of 122 Hz up to 1953 Hz.

2.3 Principle of Operation

- A magnetic flux is measured by a Hall-effect cell
- The output signal from the Hall-effect cell is converted from analog to digital signals
- The chopped Hall-effect cell and continuous-time A/D conversion ensure a very low and stable magnetic offset
- A programmable low-pass filter to reduce noise
- The temperature is measured and A/D converted
- Temperature compensation is done digitally using a second-order function
- Digital processing of the output value is based on zero field and sensitivity value
- The output value range can be clamped by digital limiters
- The final output value is transferred in a rectangular, periodic signal with varying duty cycle (Pulse Width Modulation)
- The duty cycle is proportional to the 12-bit output value

2.4 Transfer Functions

The examples in [Figure 2-2](#) show how different magnetic field ranges can be mapped to the desired output value ranges.

- Polarity Mode:
 - **Bipolar:** Magnetic fields can be measured in both orientations. The limit points do not necessarily have to be symmetrical around the zero field point
 - **Unipolar:** Only north- or south-oriented magnetic fields are measured
- Inversion: Both gain can be set to positive values, negative values or positive/negative values.

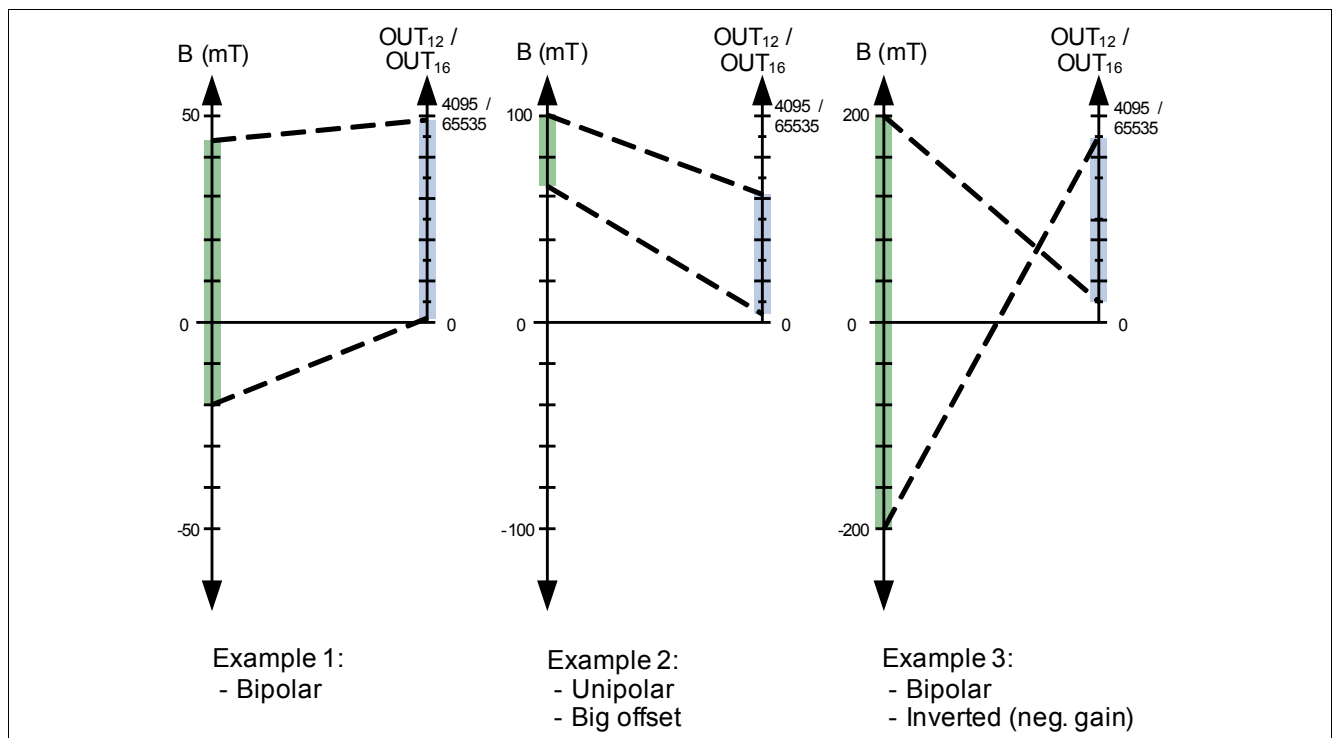

Figure 2-2 Examples of Operation

3 Maximum Ratings

All further given specifications are regarded to each of the implemented sensors IC's, or otherwise noted.

Table 3-1 Absolute Maximum Ratings

Parameter	Symbol	Values			Unit	Note / Test Condition
		Min.	Typ.	Max.		
Junction temperature	T_J	- 40	–	160 ¹⁾	°C	–
Voltage on V_{DD} pin with respect to ground	V_{DD}	-18	–	18.35	V	2)3)
Supply current @ overvoltage V_{DD} max.	I_{DDov}	–	–	15	mA	–
Reverse supply current @ V_{DD} min.	I_{DDrev}	-1	–	0	mA	–
Voltage on output pin with respect to ground	V_{OUT}	-1 ⁴⁾	–	18.35 ⁵⁾	V	–
Magnetic field	B_{MAX}	-	–	1	T	–
ESD protection	V_{ESD}	–	–	±2	kV	According HBM ANSI/ESDA/JEDEC JS-001

- 1) For limited time of 96 h. Depends on customer temperature lifetime cycle. Please ask Infineon for support.
- 2) Higher voltage stress than absolute maximum rating, e.g. 150% in latch-up tests is not applicable. In such cases, $R_{series} \geq 100 \Omega$ for current limitation is required.
- 3) Max 1h, in operating temperature range.
- 4) I_{DD} can exceed 10 mA when the voltage on OUT is pulled below -1 V (-5 V at room temperature).
- 5) $V_{DD} = 5 V$, open drain permanent low, for max. 10 minutes

Attention: Stresses above those listed under “Absolute Maximum Ratings” may cause permanent damage to the device. This is a stress rating only and functional operation of the device at these or any other conditions above those indicated in the operational sections of this specification is not implied. Furthermore, only single error cases are assumed. More than one stress/error case may also damage the device.

Exposure to absolute maximum rating conditions for extended periods may affect device reliability. During absolute maximum rating overload conditions the voltage on VDD pins with respect to ground (VSS) must not exceed the values defined by the absolute maximum ratings. Lifetime statements are an anticipation based on an extrapolation of Infineon’s qualification test results. The actual lifetime of a component depends on its form of application and type of use etc. and may deviate from such statement. The lifetime statement shall in no event extend the agreed warranty period.

4 Operating Range

The following operating conditions must not be exceeded in order to ensure correct operation of the TLE4998P8(D). All parameters specified in the following sections refer to these operating conditions and each of the implemented sensors IC's if applicable or unless otherwise indicated.

Table 4-1 Operating Range

Parameter	Symbol	Values			Unit	Note / Test Condition
		Min.	Typ.	Max.		
Supply voltage	V_{DD}	4.5	–	5.5	V	–
		4.1	–	16 ¹⁾²⁾	V	Extended range
Supply undervoltage	V_{DDuv}	V_{DDpon} ³⁾	–	4.1	V	Extended range
Output pull-up voltage ⁴⁾	$V_{pull-up}$	–	–	18.35	V	–
Load resistance ⁴⁾	R_L	1	–	–	k Ω	–
Output current ⁴⁾	I_{out}	0	–	5	mA	–
Load capacitance ⁴⁾	C_L	1	–	8	nF	–
Ambient temperature ⁵⁾	T_A	-40	–	125	$^{\circ}\text{C}$	max. 1200 h at 125 $^{\circ}\text{C}$ ⁶⁾

- 1) For supply voltages > 12 V, a series resistance $R_{series} \geq 100 \Omega$ is recommended
- 2) The open drain switch off, due to overvoltage on the V_{DD} line, can take place in the range of 16.65 V to 18.35 V, as defined in [Chapter 8.1](#) of the data sheet.
- 3) V_{DDpon} ... power-on reset level, see [Table 5-1](#)
- 4) Output protocol characteristics depend on these parameters, R_L must be according to max. output current
- 5) $R_{THja} \leq 150 \text{ K/W}$.
- 6) Maximum exposure time at other ambient temperatures between -40 $^{\circ}\text{C}$ and 125 $^{\circ}\text{C}$ shall be calculated based on the values specified in this table using the Arrhenius model.

Note: Keeping signal levels within the limits specified in this table ensures operation without overload conditions.

5 Electrical, Thermal and Magnetic Parameters

All specification values are valid over temperature and lifetime, unless noted otherwise.

5.1 Electrical Characteristics

Table 5-1 Electrical Characteristics

Parameter	Symbol	Values			Unit	Note / Test Condition
		Min.	Typ.	Max.		
Supply current	I_{DD}	3	6	8	mA	–
Thermal resistance ¹⁾	R_{thJA}	–	150	–	K/W	junction to air
	R_{thJC}	–	85	–	K/W	junction to case
Power-on time ²⁾	t_{Pon}	–	0.7	2	ms	$\leq \pm 5\%$ target out value $\leq \pm 1\%$ target out value
		–	15	20		
Power-on reset level ³⁾	V_{DDpon}	3.1	3.5	3.9	V	
Output impedance	Z_{OUT}	19	30	44	k Ω	
Output fall time	t_{fall}	2	3.5	5	μ s	V_{OUT} 4.5 V to 0.5 V ⁴⁾
Output rise time	t_{rise}	–	20	–	μ s	V_{OUT} 0.5 V to 4.5 V ⁴⁾
Output low saturation voltage	V_{OUTsat}	–	0.3	0.6	V	$I_{OUTsink} = 5$ mA
		–	0.2	0.4	V	$I_{OUTsink} = 2.2$ mA
Output noise (rms)	OUT_{noise}	–	–	2	LSB ₁₂	With LP filter setting, from 80 Hz until 1390 Hz ⁵⁾
Oscillator frequency variation	$\Delta f / f$	-20	–	20	%	Nominal oscillator frequency: 8MHz

- 1) Values derived from a simulation with a 4-layer PCB
- 2) Response time to set up output data at power on when a constant field is applied. The first value given has a $\pm 5\%$ error, the second value has a $\pm 1\%$ error.
- 3) Power-on and power-off
- 4) Depends on External R_L and C_L , See [Figure 5-1](#)
- 5) Range ± 50 mT (also valid for ranges ± 100 mT and ± 200 mT), Gain 1.0 (scales linearly with gain)

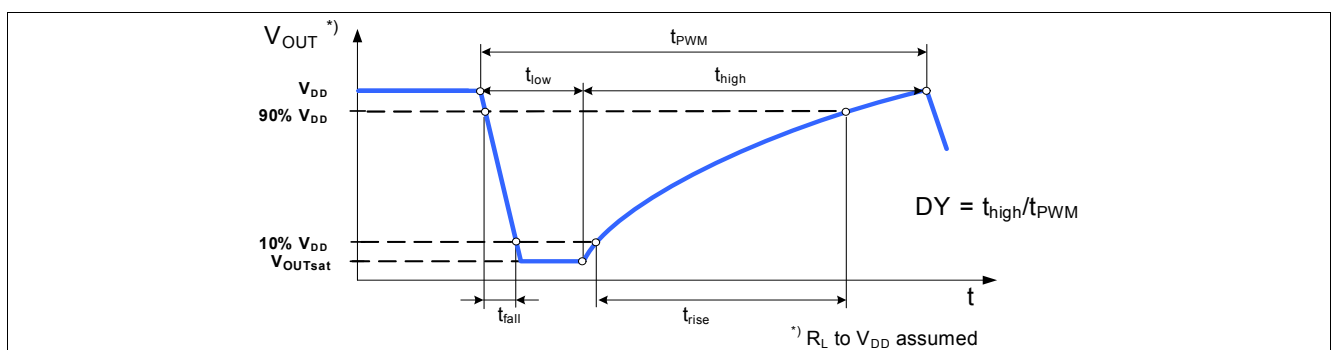

Figure 5-1 Output Characteristic

Calculation of the Junction Temperature

The internal power dissipation P_{TOT} of the sensor increases the chip junction temperature above the ambient temperature.

The power multiplied by the total thermal resistance R_{thJA} (Junction to Ambient) added to T_A leads to the final junction temperature. R_{thJA} is the sum of the addition of the two components, Junction to Case and Case to Ambient.

$$R_{thJA} = R_{thJC} + R_{thCA}$$

$$T_J = T_A + \Delta T = R_{thJA} \times P_{TOT} = R_{thJA} \times (V_{DD} \times I_{DD} + V_{OUT} \times I_{OUT}); I_{DD}, I_{OUT} > 0, \text{ if direction is into IC}$$

Example (assuming no load on V_{OUT} and TLE4998P8(D) type):

- $V_{DD} = 5 \text{ V}$
- $I_{DD} = 8 \text{ mA}$
- $\Delta T = 150[\text{K/W}] \times (5 [\text{V}] \times 0.008 [\text{A}] + 0 [\text{VA}]) = 6 \text{ K per silicon}$

For molded sensors, the calculation with R_{thJC} is more adequate.

5.2 Magnetic Characteristics
Table 5-2 Magnetic Characteristics

Parameter	Symbol	Values			Unit	Note / Test Condition
		Min.	Typ.	Max.		
Sensitivity	$S^{1)}$	± 0.2	± 1.2	± 5.5	%/mT	programmable ²⁾
Sensitivity drift	ΔS	-2.0	–	+2.0	%	
Magnetic field range	MFR	± 50	± 100	± 200	mT	programmable ³⁾
Integral nonlinearity	INL	–	± 2.0	± 4.1	LSB ₁₂	⁴⁾
Magnetic offset	B_{OS}	–	± 100	± 400	μT	
Magnetic offset drift	ΔB_{OS}	–	± 1	± 5	$\mu\text{T}/^\circ\text{C}$	error band
Magnetic hysteresis	B_{HYS}	–	–	20 10	μT	in 50mT range in 100mT range

1) Defined as $\Delta DY_{PVM} / \Delta B$; (DY = PWM duty cycle)

2) Programmable in steps of 0.024%.

3) Depending on offset and gain settings, the output may already be saturated at lower fields.

4) Range $\pm 50 \text{ mT}$ (also valid for ranges $\pm 100 \text{ mT}$ and $\pm 200 \text{ mT}$), Gain = 1.0 (scales linearly with gain)

5.3 Electrical and Magnetic Characteristics in Undervoltage Range

Table 5-3 Electrical and Magnetic Characteristics in Supply Undervoltage Range

Parameter	Symbol	Values			Unit	Note / Test Condition
		Min.	Typ.	Max.		
Sensitivity drift	$S_{E(T)}$	–	–	+2.5/-7.5	%	
Magnetic offset drift	ΔB_{OS}	–	–	± 400	μT	
Integral nonlinearity	INL	–	–	± 8.2	LSB ₁₂	1)
Output noise (rms)	OUT _{noise}	–	–	8	LSB ₁₂	With LP filter setting, from 80 Hz until 1390 Hz ¹⁾

1) Range ± 50 mT (also valid for ranges ± 100 mT and ± 200 mT), Gain = 1.0 (scales linearly with gain)

5.4 Magnetic Field Direction Definition

Figure 5-2 shows the definition of the magnetic field direction. By standard the south pole field defines the positive field values of the top die of TLE4998P8(D).

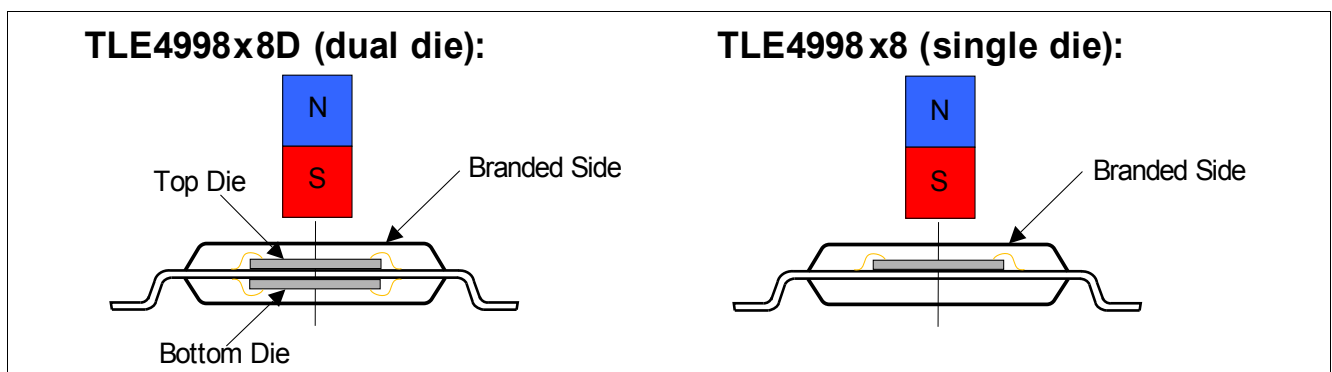

Figure 5-2 Definition of magnetic field direction of the TLE4998P8(D).

Without reconfiguration the bottom die measures the inverted field value of the top die. This leads to a default output characteristic as shown in **Figure 5-3**.

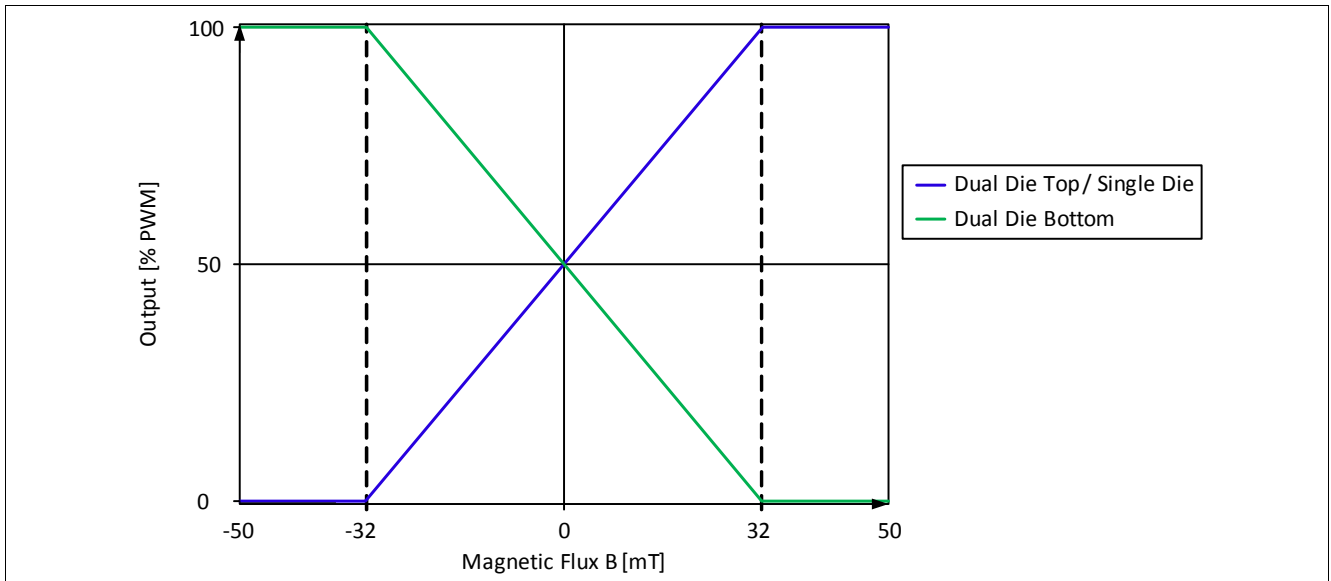

Figure 5-3 Example of the dual die output characteristic (range 50 mT, gain 1.0, typical)

6 Application Circuit

Figure 6-1 shows the connection of two Linear Hall sensors to a microcontroller.

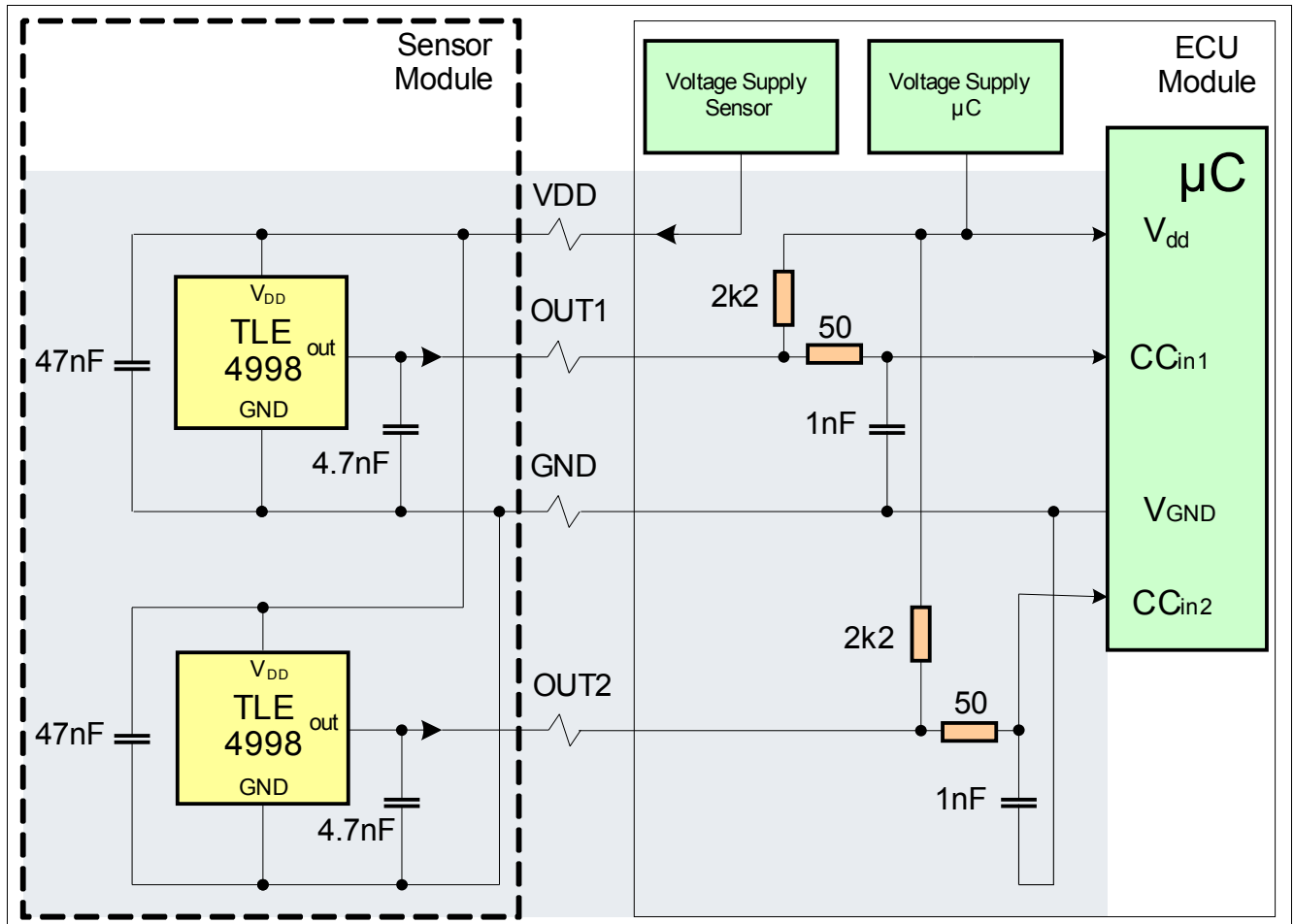

Figure 6-1 Application Circuit

The application circuit shown should be regarded as an example only.

7 Configuration and Calibration Parameters

The TLE4998P8(D) has several configurable parameters which are stored in the EEPROM. These parameters affect the internal data processing and compensation and the output protocol. This chapter gives an overview of the parameters. A detailed description of all the parameters and the programming procedure is given in the [TLE4998 User's Manual](#).

Table 7-1 TLE4998P8(D) Parameters

Parameter	Setting range	Note
Magnetic range	±50 mT ±100 mT ±200 mT	Magnetic input range of Hall ADC
Gain	-4.0...4.0	Gain value of +1.0 corresponds to typical 32 LSB ₁₂ /mT sensitivity in 100 mT range (64 LSB ₁₂ /mT in 50mT range)
Offset	-400 %DY... 399 %DY ¹⁾	Quantization step: 0.024 %DY
Clamping low level	0 %DY ... 100% DY	Quantization step: 0.78 %DY (see Figure 7-1)
Clamping high level	0 %DY ... 100% DY	Quantization step: 0.78 %DY
Bandwidth ²⁾	80 Hz 240 Hz 440 Hz 640 Hz 860 Hz 1100 Hz 1390 Hz Off	Low-pass filter cut-off (-3 dB) frequency (see Figure 7-2)
1 st order temperature coefficient TC ₁	-1000 ppm/°C ... 2500 ppm/°C	³⁾
2 nd order temperature coefficient TC ₂	-4 ppm/°C ² ... 4 ppm/°C ²	⁴⁾
PWM output frequency ²⁾	122 Hz ... 244 Hz 279 Hz 325 Hz 391 Hz 488 Hz 651 Hz 977 Hz 1953 Hz	$f_{\text{PWM}} = 1953 \text{ Hz} / (\text{Predivider} + 1)$ with Predivider configurable from 0 to 15.

1) DY = PWM duty cycle

2) Subject to oscillator variation ±20%.

3) Relative range to Infineon temperature pre-calibration, the maximum adjustable range is limited by the register-size and depends on specific pre-calibrated TL setting, full adjustable range: -2441 to +5355 ppm/°C.

4) Relative range to Infineon temperature pre-calibration, the maximum adjustable range is limited by the register-size and depends on specific pre-calibrated TQ setting, full adjustable range: -15 to +15 ppm/°C².

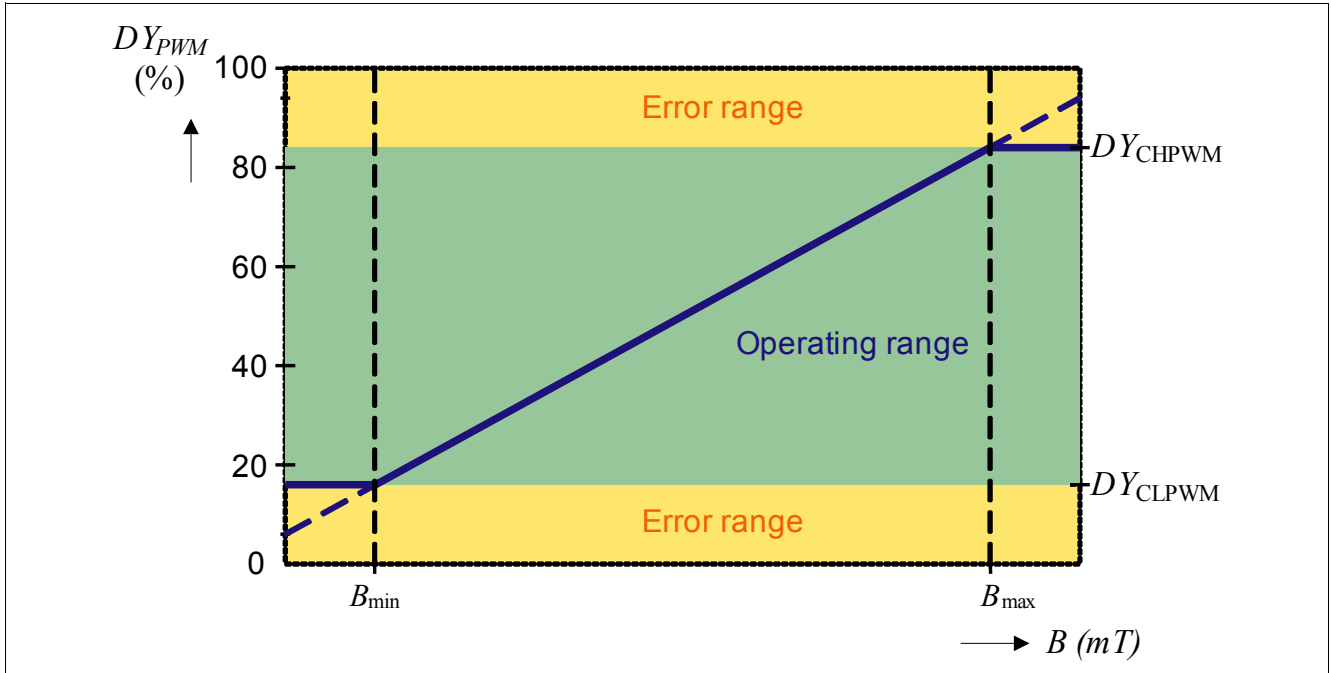

Figure 7-1 Clamping Example

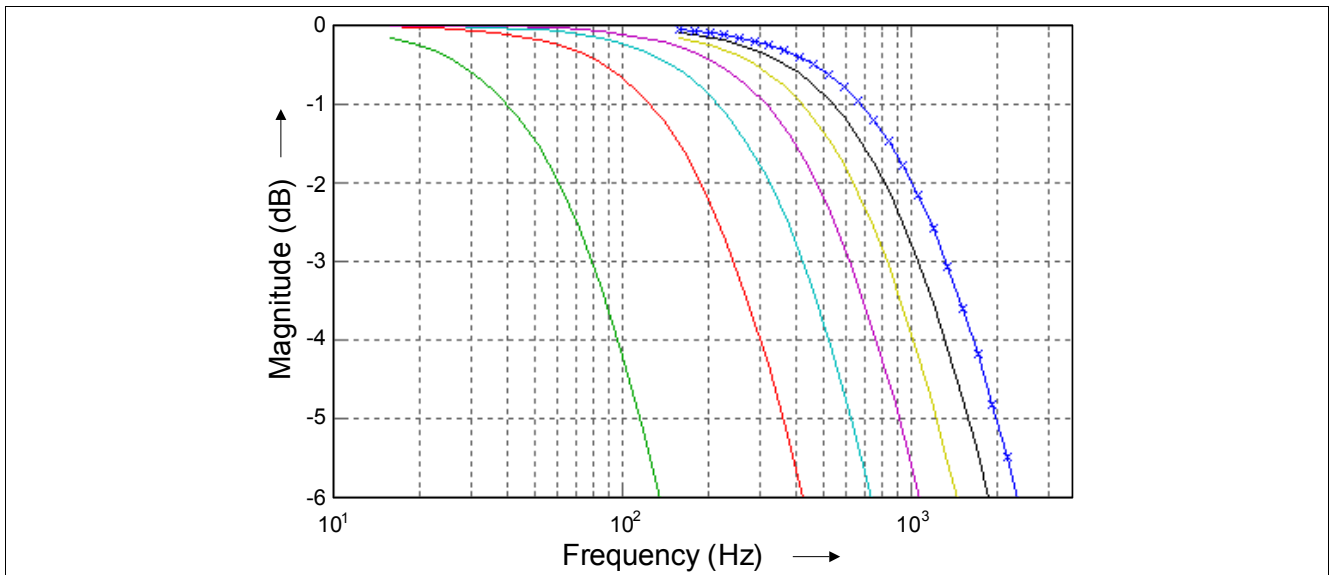

Figure 7-2 DSP Input Filter (Magnitude Plot)

8 Error Detection

Different error cases can be detected by the On-Board-Diagnostics (OBD) and reported to the micro controller. The OBD can only be used with the clamping functionality enabled.

8.1 Voltages Outside the Operating Range

- Inside the ratings specified in [Table 3-1 “Absolute Maximum Ratings” on Page 8](#)
- Outside the range specified in [Table 4-1 “Operating Range” on Page 9](#)

The output signals an error condition if V_{DD} crosses the overvoltage threshold level.

Table 8-1 Overvoltage

Parameter	Symbol	Values			Unit	Note / Test Condition
		Min.	Typ.	Max.		
Overvoltage threshold	V_{DDov}	16.65	17.5	18.35	V	
Output duty cycle @ EEPROM error	CY_{PwMov}	100 ¹⁾	–	–	–	

1) Output stays in “off” state (high ohmic)

8.2 EEPROM Error Correction

The parity method is able to correct a single bit in the EEPROM line. One other single bit error in another EEPROM line can also be detected, but not corrected. In case there is an incorruptable EEPROM failure, the open drain stage is disabled and permanently kept in off state (high ohmic/sensor defect).

9 PG-TDSO-8 Package Outlines

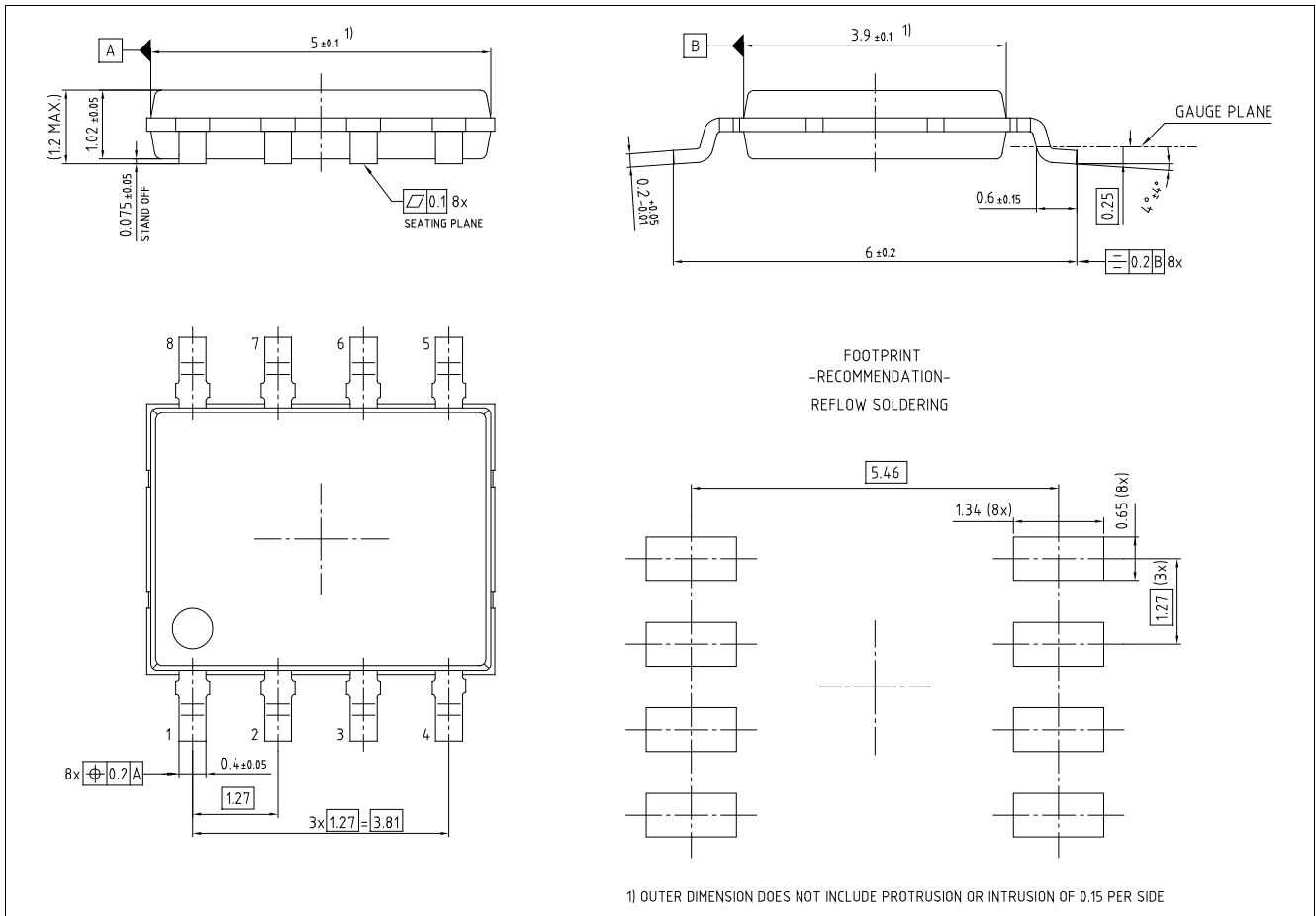

Figure 9-1 PG-TDSO-8 (PG-TDSO-Plastic Green Thin Dual Small Outline), Package Dimensions

9.1 Distance Chip to package

Figure 9-2 shows the distance of the chip surface to the PG-TDSO-8 surface.

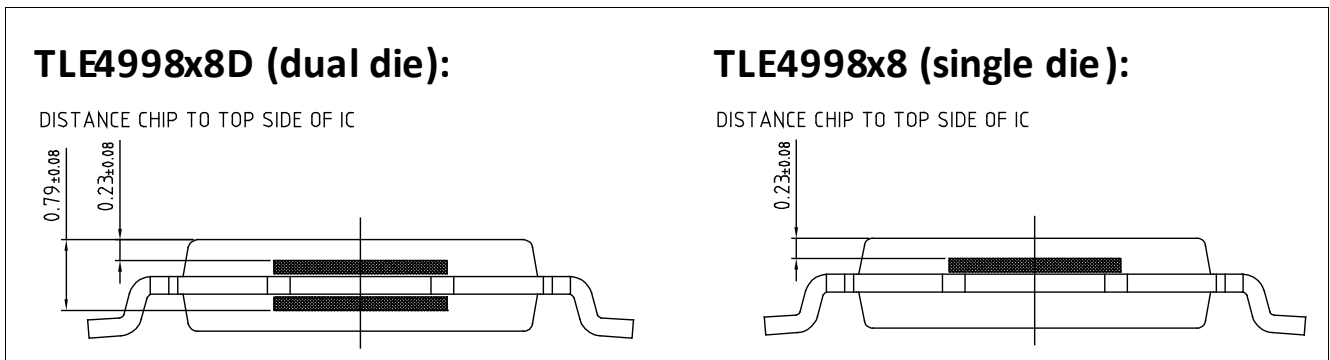

Figure 9-2 Distance of chip surface to package surface

9.2 Moisture Sensitivity Level (MSL)

The PG-TDSO-8 fulfills the MSL level 3 according to IPC/JEDEC J-STD-033B.1.

9.3 PG-TDSO-8 Package Marking

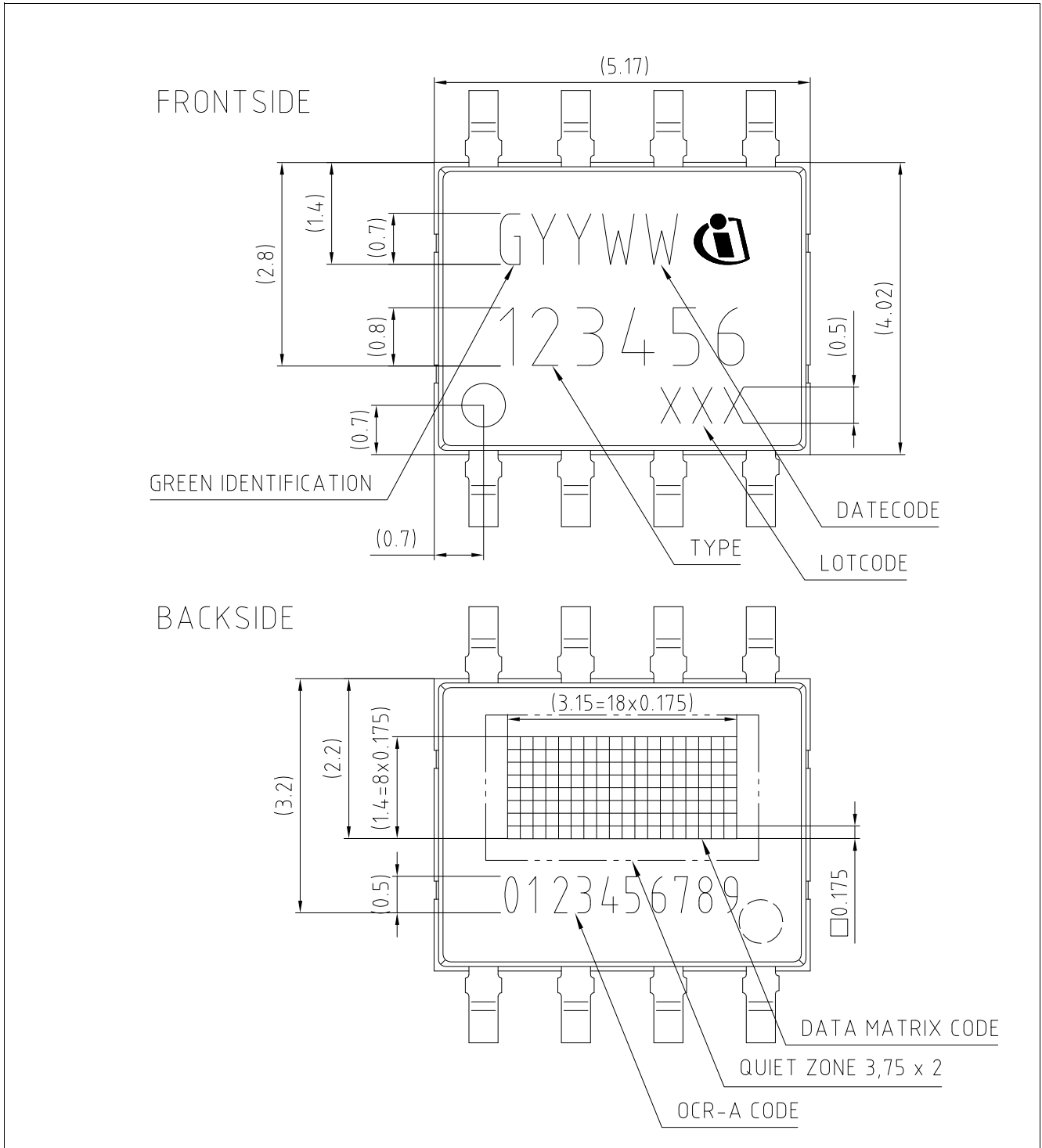

Figure 9-3 PG-TDSO-8 (PG-TDSO-Plastic Green Thin Dual Small Outline), Package Marking

Revision History

Page or Item	Subjects (major changes since previous revision)
Revision 1.1, 2017-01	
Page 10	Added Note / Test Condition to parameter Output noise (rms)
Page 12	Added Note / Test Condition to parameter Output noise (rms)

Trademarks of Infineon Technologies AG

AURIX™, C166™, CanPAK™, CIPOS™, CIPURSE™, EconoPACK™, CoolMOS™, CoolSET™, CORECONTROL™, CROSSAVE™, DAVE™, EasyPIM™, EconoBRIDGE™, EconoDUAL™, EconoPIM™, EiceDRIVER™, eupec™, FCOS™, HITFET™, HybridPACK™, I²RF™, ISOFACE™, IsoPACK™, MIPAQ™, ModSTACK™, my-d™, NovalithIC™, OptiMOS™, ORIGA™, PRIMARION™, PrimePACK™, PrimeSTACK™, PRO-SIL™, PROFET™, RASIC™, ReverSave™, SatRIC™, SIEGET™, SINDRION™, SIPMOS™, SmartLEWIS™, SOLID FLASH™, TEMPFET™, thinQ!™, TRENCHSTOP™, TriCore™.

Other Trademarks

Advance Design System™ (ADS) of Agilent Technologies, AMBA™, ARM™, MULTI-ICE™, KEIL™, PRIMECELL™, REALVIEW™, THUMB™, μVision™ of ARM Limited, UK. AUTOSAR™ is licensed by AUTOSAR development partnership. Bluetooth™ of Bluetooth SIG Inc. CAT-iq™ of DECT Forum. COLOSSUS™, FirstGPS™ of Trimble Navigation Ltd. EMV™ of EMVCo, LLC (Visa Holdings Inc.). EPCOS™ of Epcos AG. FLEXGO™ of Microsoft Corporation. FlexRay™ is licensed by FlexRay Consortium. HYPERTERMINAL™ of Hilgraeve Incorporated. IEC™ of Commission Electrotechnique Internationale. IrDA™ of Infrared Data Association Corporation. ISO™ of INTERNATIONAL ORGANIZATION FOR STANDARDIZATION. MATLAB™ of MathWorks, Inc. MAXIM™ of Maxim Integrated Products, Inc. MICROTEC™, NUCLEUS™ of Mentor Graphics Corporation. Mifare™ of NXP. MIPI™ of MIPI Alliance, Inc. MIPS™ of MIPS Technologies, Inc., USA. muRata™ of MURATA MANUFACTURING CO., MICROWAVE OFFICE™ (MWO) of Applied Wave Research Inc., OmniVision™ of OmniVision Technologies, Inc. Openwave™ Openwave Systems Inc. RED HAT™ Red Hat, Inc. RFMD™ RF Micro Devices, Inc. SIRIUS™ of Sirius Satellite Radio Inc. SOLARIS™ of Sun Microsystems, Inc. SPANSION™ of Spansion LLC Ltd. Symbian™ of Symbian Software Limited. TAIYO YUDEN™ of Taiyo Yuden Co. TEAKLITE™ of CEVA, Inc. TEKTRONIX™ of Tektronix Inc. TOKO™ of TOKO KABUSHIKI KAISHA TA. UNIX™ of X/Open Company Limited. VERILOG™, PALLADIUM™ of Cadence Design Systems, Inc. VLYNQ™ of Texas Instruments Incorporated. VXWORKS™, WIND RIVER™ of WIND RIVER SYSTEMS, INC. ZETEX™ of Diodes Zetex Limited.

Last Trademarks Update 2011-02-24

www.infineon.com

Published by Infineon Technologies AG